

(19) World Intellectual Property Organization
International Bureau



(43) International Publication Date
4 January 2007 (04.01.2007)

PCT

(10) International Publication Number
WO 2007/002307 A2

(51) International Patent Classification: Not classified

(21) International Application Number:
PCT/US2006/024334

(22) International Filing Date: 21 June 2006 (21.06.2006)

(25) Filing Language: English

(26) Publication Language: English

(30) Priority Data:
60/693,531 24 June 2005 (24.06.2005) US
11/455,993 19 June 2006 (19.06.2006) US

(71) Applicant (for all designated States except US): **ABBOTT LABORATORIES** [US/US]; 100 Abbott Park Road, Abbott Park, Illinois 60064 (US).

(72) Inventor; and

(75) Inventor/Applicant (for US only): **CARLY, Michael, T.** [US/US]; San Jose, California (US).

(74) Agents: **LOUIE, Michael, L.** et al.; Beyer Weaver & Thomas, Llp, P.o. Box 70250, Oakland, California 94612-0250 (US).

(81) Designated States (unless otherwise indicated, for every kind of national protection available): AE, AG, AL, AM, AT, AU, AZ, BA, BB, BG, BR, BW, BY, BZ, CA, CH, CN, CO, CR, CU, CZ, DE, DK, DM, DZ, EC, EE, EG, ES, FI, GB, GD, GE, GH, GM, HN, HR, HU, ID, IL, IN, IS, JP, KE, KG, KM, KN, KP, KR, KZ, LA, LC, LK, LR, LS, LT, LU, LV, LY, MA, MD, MG, MK, MN, MW, MX, MZ, NA, NG, NI, NO, NZ, OM, PG, PH, PL, PT, RO, RS, RU, SC, SD, SE, SG, SK, SL, SM, SY, TJ, TM, TN, TR, TT, TZ, UA, UG, US, UZ, VC, VN, ZA, ZM, ZW.

(84) Designated States (unless otherwise indicated, for every kind of regional protection available): ARIPO (BW, GH, GM, KE, LS, MW, MZ, NA, SD, SL, SZ, TZ, UG, ZM, ZW), Eurasian (AM, AZ, BY, KG, KZ, MD, RU, TJ, TM), European (AT, BE, BG, CH, CY, CZ, DE, DK, EE, ES, FI, FR, GB, GR, HU, IE, IS, IT, LT, LU, LV, MC, NL, PL, PT, RO, SE, SI, SK, TR), OAPI (BF, BJ, CF, CG, CI, CM, GA, GN, GQ, GW, ML, MR, NE, SN, TD, TG).

Published:
— without international search report and to be republished upon receipt of that report

For two-letter codes and other abbreviations, refer to the "Guidance Notes on Codes and Abbreviations" appearing at the beginning of each regular issue of the PCT Gazette.

(54) Title: APPARATUS AND METHOD FOR DELIVERING A CLOSURE ELEMENT

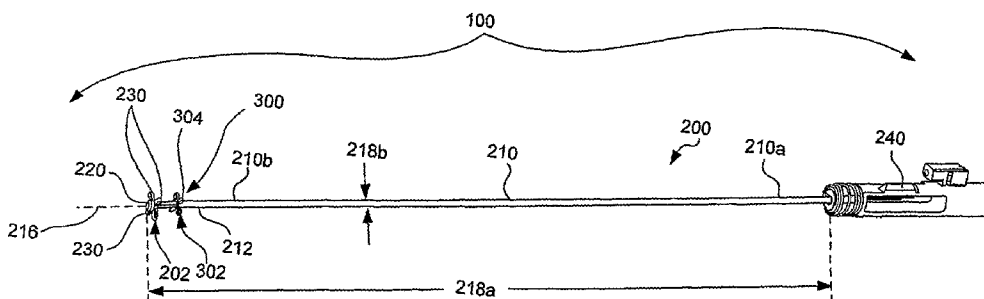

(57) Abstract: An apparatus for delivering and deploying a closure element to an opening formed in a body lumen, including a delivery assembly positionable through the tissue and into the opening. The delivery assembly includes a distal locator portion and a carrier portion oriented proximal to the distal locator portion. The distal locator portion is configured to selectably engage the body lumen adjacent to the opening, and the carrier portion is configured to carry and support the closure element in a substantially tubular configuration. The carrier portion is further configured to urge the closure element toward an expanded cross-sectional dimension for deployment thereof, such that the closure element is oriented to engage the tissue when deployed and, when released, to return to the natural, substantially planar configuration and the natural cross-section dimension wherein the engaged tissue is drawn substantially closed.



WO 2007/002307 A2

APPARATUS AND METHOD FOR DELIVERING A CLOSURE ELEMENT

FIELD OF THE INVENTION

5 [001] The present invention relates generally to apparatus and methods for closing and/or sealing openings through tissue, and more particularly to apparatus and methods for delivering a closure element for closing a puncture in a blood vessel or other body lumen formed during a diagnostic or therapeutic procedure.

10 BACKGROUND OF THE INVENTION

[002] Catheterization and interventional procedures, such as angioplasty or stenting, generally are performed by inserting a hollow needle through a patient's skin and tissue into the vascular system. A guide wire may be advanced through the needle and into the patient's blood vessel accessed by the needle. The needle then is
15 removed, enabling an introducer sheath to be advanced over the guide wire into the vessel, e.g., in conjunction with or subsequent to a dilator. A catheter or other device may then be advanced through a lumen of the introducer sheath and over the guide wire into a position for performing a medical procedure. Thus, the introducer sheath may facilitate introducing various devices into the vessel, while minimizing trauma to
20 the vessel wall and/or minimizing blood loss during a procedure.

[003] Upon completing the procedure, the devices and introducer sheath may be removed, leaving a puncture site in the vessel wall. External pressure may be applied to the puncture site until clotting and wound sealing occur. This procedure, however,
25 may be time consuming and expensive, requiring as much as an hour of a physician's or nurse's time. It is also uncomfortable for the patient, and requires that the patient remain immobilized in the operating room, catheter lab, or holding area. In addition, a risk of hematoma exists from bleeding before hemostasis occurs.

30 [004] Various apparatus have been suggested for percutaneously sealing a vascular puncture by occluding the puncture site. For example, U.S. Pat. Nos. 5,192,302 and 5,222,974, issued to Kensey et al., describe the use of a biodegradable plug that may be delivered through an introducer sheath into a puncture site. Another

technique has been suggested that involves percutaneously suturing the puncture site, such as that disclosed in U.S. Pat. No. 5,304,184, issued to Hathaway et al.

5 [005] To facilitate positioning devices that are percutaneously inserted into a blood vessel, "bleed back" indicators have been suggested. For example, U.S. Pat. No. 5,676,974, issued to Kensey et al., discloses a bleed back lumen intended to facilitate positioning of a biodegradable plug within a puncture site. This device, however, requires that an anchor of the plug be positioned within the vessel, and therefore, may increase the risk of over-advancement of the plug itself into the vessel.

10

[006] Alternatively, U.S. Pat. No. 5,674,231, issued to Green et al., discloses a deployable loop that may be advanced through a sheath into a vessel. The loop is intended to resiliently expand to engage the inner wall of the vessel, thereby facilitating holding the sheath in a desired location with respect to the vessel.

15

[007] Accordingly, apparatus and methods for delivering a device for closing a vascular puncture site or other opening through tissue would be useful.

SUMMARY OF THE INVENTION

20 [008] The present invention is directed toward an apparatus and method for delivering a closure element through tissue and into an opening formed in, or adjacent to, a wall of a blood vessel or other body lumen of any size.

25 [009] The delivery apparatus is configured to receive and retain the closure element such that the closure element is disposed substantially within the apparatus during advancement to the lumen opening. Thereby, if the apparatus is introduced via an introducer sheath, for example, the closure element can be disposed within, and delivered by way of, a lumen of the introducer sheath. The apparatus also is configured to engage the blood vessel wall adjacent to the opening and to position the
30 closure element substantially adjacent to an outer surface of the blood vessel wall adjacent to the opening.

[010] When properly positioned, the apparatus can be activated to distally deploy the closure element. During deployment, the apparatus preferably is configured to substantially uniformly expand the closure element beyond a natural cross-section of the closure element such that the closure element, when deployed, is configured to engage significant amount of the blood vessel wall and/or tissue. Engaging the blood vessel wall and/or tissue, the closure element is further configured to return to the natural cross-section. Thereby, the engaged blood vessel wall and/or tissue are drawn substantially closed and/or sealed, such that, for example, hemostasis within the opening is enhanced.

[011] An apparatus is provided, hence, for delivering and deploying a resilient closure element to an opening formed in a body lumen. The closure element is configured to resiliently deform between a natural, substantially planar configuration to a substantially tubular configuration. Further, the closure element is configured to substantially radially displace between a reduced substantially tubular configuration and an expanded substantially tubular configuration having a greater cross-sectional dimension. The delivery apparatus includes a delivery assembly positionable through the tissue and into the opening in the body lumen. The assembly includes a distal locator portion and a carrier portion oriented proximal to the distal locator portion. The distal locator portion is configured to selectably engage the body lumen adjacent to the opening, and the carrier portion is configured to carry and support the closure element, in the reduced substantially tubular configuration. Further, the carrier portion is configured to urge the closure element toward the expanded substantially tubular configuration for deployment thereof. The closure element is oriented to engage the tissue when deployed in the expanded substantially tubular configuration, and to return toward the natural, substantially planar configuration such that the engaged tissue is drawn substantially closed.

[012] In one specific embodiment, a cover member is included that protects the delivery assembly such that at least the carrier portion and the closure element, in the reduced substantially tubular configuration, are fully contained therein, in a support configuration. The cover member defines a lumen sized and dimensioned for relative

axial sliding receipt of the delivery assembly therein for movement from the support configuration to a pre-deployment configuration. In the pre-deployment configuration, at least a distal portion of the closure element is exposed to enable radial expansion thereof by the carrier portion from the reduced in the reduced substantially tubular configuration to the expanded substantially tubular configuration.

[013] In another specific embodiment, the distal portion of the cover member includes a plurality of substantially resilient extension members that are tapered radially inward. In the pre-deployment configuration, each extension member is configured to retain at least a proximal portion of the closure element against the carrier portion as the carrier portion is selectably moved from an unexpanded state to an expanded state. Consequently, the closure element is urged from the reduced substantially tubular configuration to the expanded substantially tubular configuration, for deployment thereof.

[014] The carrier portion also preferably includes one or more expansion elements configured to expand substantially transversely with respect to a longitudinal axis of the carrier portion. Hence, the proximal carrier portion can be in the form of a proximal obturator, while the distal locator portion can also be essentially a distal obturator.

[015] In yet another configuration, the distal obturator is selectively controlled by a locator control system coupled to a proximal end region of the delivery assembly. In particular, the locator control system selectively controls movement of the distal locator portion between the expanded state and the unexpanded state. Similarly, a carrier control system selectively controls movement of the carrier portion between the expanded state and the unexpanded state.

[016] In one specific embodiment, a pusher member is included that is slideably disposed within the cover member. The pusher member includes a contact end region configured to distally displace the closure member longitudinally along the delivery assembly. The delivery assembly, the pusher member and the cover member are provided as a plurality of nested, telescoping members with a substantially common

longitudinal axis. Further, the contact end region of the pusher member includes one or more longitudinal extensions extending distally therefrom. The extensions are further configured to expand radially as the distal end region of the pusher member moves distally and engages a distally-increasing transverse cross-sectional dimension of the carrier portion.

[017] In another aspect of the present invention, a method is provided for closing an opening formed in a body lumen. The method includes extending a distal end region of a distal locator portion of a delivery apparatus through tissue into the opening in the body lumen, and engaging the body lumen adjacent to the opening. A carrier portion of the delivery apparatus is further positioned through the tissue adjacent to the opening. The carrier portion is proximally disposed relative to the locator portion, and the carrier portion, in an unexpanded state, is configured to support a resilient closure element, naturally in a substantially planar configuration, in a reduced substantially tubular configuration. The closure element is radially expanded from the reduced, substantially tubular configuration to an expanded, substantially tubular configuration, via the carrier portion. Subsequently, the closure element is distally deployed from the carrier portion, such that the closure element substantially uniformly expands to a cross-section that is greater than a natural cross-section of the closure element. The closure element then engages the tissue, and returns to the natural, planar configuration and the natural cross-section such that the tissue is drawn substantially closed.

BRIEF DESCRIPTION OF THE DRAWINGS

[018] The assembly of the present invention has other objects and features of advantage that will be more readily apparent from the following description of the best mode of carrying out the invention and the appended claims, when taken in conjunction with the accompanying drawing, in which:

[019] FIG. 1 provides a general illustration of an apparatus for closing openings formed in blood vessel walls in accordance with the present invention.

[020] FIG. 2 illustrates one embodiment of a delivery assembly for the apparatus of FIG. 1.

[021] FIG. 3A illustrates a top view of one embodiment of a closure element in a natural, planar configuration and with a natural cross-section for use with the apparatus of FIG. 1.

[022] FIG. 3B illustrates a side view of the closure element of FIG. 3A.

[023] FIG. 3C illustrates a top view of the closure element of FIGS. 3A-3B after a natural cross-section of the closure element has been reduced.

[024] FIG. 3D illustrates a side view of the reduced closure element of FIG. 3C.

[025] FIG. 3E illustrates a side view of the reduced closure element of FIGS. 3C-3D as the reduced closure element transitions from the natural, planar configuration to a tubular configuration.

[026] FIG. 3F illustrates a top view of the closure element of FIGS. 3C-3D upon completing the transition from the natural, planar configuration to a substantially tubular configuration.

[027] FIG. 3G illustrates a side view of the closure element of FIG. 3F.

[028] FIG. 4A illustrates one embodiment of a distal locator portion and a deployment device of a carrier portion of FIG. 2, both of which are illustrated in an unexpanded state.

[029] FIG. 4B illustrates the distal locator portion and a deployment device of FIG. 4A, both of which are illustrated in an expanded state.

[030] FIG. 4C illustrates one embodiment of a proximal end region of the delivery assembly of FIG. 2.

[031] FIG. 5A illustrates one embodiment of a carrier portion for the apparatus of FIG. 1.

5 [032] FIG. 5B illustrates one embodiment of a pusher member for the carrier portion of FIG. 5A.

[033] FIG. 5C illustrates one embodiment of a cover member for the carrier portion of FIG. 5A.

10

[034] FIG. 6 illustrates a tube set and the delivery assembly of the apparatus of FIG. 1 mounted to a handle portion for operative manipulation thereof.

15 [035] FIG. 7A illustrates the closure element of FIGS. 3A-3G prior to being disposed upon the carrier portion of FIG. 5A.

[036] FIG. 7B illustrates the closure element of FIGS. 3A-3G upon being disposed upon the carrier portion of FIG. 5A, and further as the cover member of FIG. 5C receives the carrier portion.

20

[037] FIG. 7C illustrates the closure element of FIGS. 3A-3G being retained substantially within the carrier portion of FIG. 5A when the carrier portion is disposed substantially within the cover member of FIG. 3C.

25 [038] FIG. 8A illustrates a sheath that is positioned through tissue and into an opening formed in a wall of a blood vessel.

[039] FIG. 8B illustrates the locator portion and the carrier portion of the delivery assembly of the apparatus being advanced distally into the blood vessel.

30

[040] FIG. 8C illustrates a distal end region of the locator portion of FIG. 8B extending into the blood vessel and being transitioned into an expanded state.

[041] FIG. 8D illustrates the distal end region of the locator portion of FIG. 8C being retracted proximally to engage an inner surface of the blood vessel wall.

5 [042] FIG. 8E illustrates a carrier portion of the apparatus of FIG. 8D with the cover member thereof being retracted to expose a portion of the closure element once the distal end region of FIG. 8D has engaged the inner surface of the blood vessel wall.

10 [043] FIG. 8F illustrates a deployment device of the carrier portion of FIG. 8E being transitioned into an expanded state and beginning to distally deploy the closure element.

[044] FIG. 8G illustrates the closure element of FIG. 8F upon being deployed and engaging tissue adjacent to the opening in the blood vessel wall.

15 [045] FIG. 8H illustrates the closure element of FIG. 8G transitioning from the substantially tubular configuration to the natural, planar configuration while engaging the engaged tissue.

20 [046] FIG. 8I illustrates the closure element of FIG. 8H drawing the engaged tissue substantially closed and/or sealed

DETAILED DESCRIPTION OF THE PREFERRED EMBODIMENTS

[047] While the present invention will be described with reference to a few
25 specific embodiments, the description is illustrative of the invention and is not to be construed as limiting the invention. Various modifications to the present invention can be made to the preferred embodiments by those skilled in the art without departing from the true spirit and scope of the invention as defined by the appended claims. It will be noted here that for a better understanding, like components are
30 designated by like reference numerals throughout the various figures.

[048] Referring now generally to FIGS. 1-4 and 8A-8H, a clip or closure applicator apparatus, generally designated 100, is provided for delivering and deploying a

closure element 500 to an opening 610 formed in a body lumen, such as a blood vessel 600. Briefly, as shown in FIGS. 3A-3G, the closure element 500 is configured to resiliently deform between a natural, substantially planar configuration (FIG. 3A) to a substantially tubular configuration (FIG. 3F and 3G). Further, the closure element is configured to substantially radially displace between a reduced substantially tubular configuration (when mounted on the apparatus in a support configuration (FIG. 8B-8E) and an expanded substantially tubular configuration (FIG. 8F and 8G), having a greater cross-sectional dimension. The apparatus 100 includes a delivery assembly, generally designated 200, positionable through the tissue 630 and into the opening 610. The apparatus includes distal locator portion 202 and a carrier portion 300 oriented proximal to the distal locator portion. The distal locator portion 202 is configured to selectably engage the body lumen 600 adjacent to the opening 610 (FIGS. 8D and 8E), and the carrier portion 300 is configured to carry and support the closure element 500 in the reduced, substantially tubular configuration (FIG. 8B-8E), and further configured to urge the closure element 500 toward the expanded, substantially tubular configuration for deployment thereof (FIG. 8G). When deployed, the closure element 500 is oriented to engage the blood vessel wall 620 and/or the tissue 630 around the opening 610, and to return to the natural, substantially planar configuration and the natural cross-section such that the engaged tissue is drawn substantially closed (FIG. 8H).

[049] Accordingly, the reduced complexity of the present inventive closure applier enables a diametric footprint that is significantly smaller than previous designs. Moreover, a closure applier apparatus is provided that fully encloses the closure element therein before deployment and delivery to the targeted vessel walls. This reduces potential tissue snag by the closure element during positioning. Hence, since the current apparatuses for sealing openings formed in blood vessel walls can snag tissue adjacent to the openings during positioning and may not provide an adequate seal, this apparatus, as well as co-pending U.S. Patent App. S/N 10/356,214, filed January 30, 2003, entitled "CLIP APPLIER AND METHODS OF USE" (hereinafter referred to as the '214 Patent Application), and herein incorporated by reference in its entirety, is configured to prevent inadvertent tissue contact during positioning and to engage a substantial amount of tissue adjacent to the opening. This

proves much more desirable and provides a basis for a wide range of medical applications, such as diagnostic and/or therapeutic procedures involving blood vessels or other body lumens of any size. This result can be achieved, according to one embodiment of the present invention, by employing an apparatus 100 as shown in
5 FIGS. 1 and 2.

[050] As will be discussed in more detail below, the apparatus 100 can deliver a closure element 500 (shown in FIGS. 3A-B) through tissue 630 (shown in FIG. 8A) and into an opening 610 formed in and/or adjacent to a wall 620 of a blood vessel 600 or other body lumen. The closure element (or clip) 500 preferably has a generally
10 annular-shape body 510 (shown in FIGS. 3A-3B) defining a channel 540 and one or more barbs and/or tines 520 for receiving and engaging the blood vessel wall 620 and/or the tissue 630 around the opening 610. Although the closure element 500 has a natural shape and size, the closure element 500 can be deformed into other shapes and
15 sizes, as desired, and is configured to return to the natural shape and size when released. For example, the closure element 500 can have a natural, planar configuration with opposing tines 520 and a natural cross-section 530 as shown in FIGS. 3A-3B. The natural cross-section 530 of the closure element 500 can be reduced to form a reduced closure element 500' that has a natural, planar configuration
20 with opposing tines 520 and a reduced cross-section 530' as shown in FIGS. 3C-3D. By rotating the opposing tines 520 axially as shown in FIG. 3E, the reduced closure element 500' can be further deformed to form a substantially tubular closure element 500" (shown in FIG. 3F). In this reduced, substantially tubular configuration with the tines 520 in an axial configuration (FIG. 3G which is the configuration when loaded
25 on the carrier portion configuration), the resulting cross-section 530' is reduced as well.

[051] Being configured to draw the blood vessel wall 620 and/or the tissue 630 adjacent to the opening 610 substantially closed and/or to enhance hemostasis within
30 the opening 610, the closure element 500 can be formed from any suitable material, including any biodegradable material, any shape memory alloy, such as alloys of nickel-titanium, or any combination thereof. As desired, the closure element 500 can include radiopaque markers (not shown) or can be wholly or partially formed from a

radiopaque material to facilitate observation of the closure element 500 using fluoroscopy or other imaging systems. Exemplary embodiments of a closure element are disclosed in U.S. Pat. No. 6,197,042, in co-pending application Ser. Nos.: 09/546,998, 09/610,238 and 10/081,726. The disclosures of these references and any
5 others cited therein are expressly incorporated herein by reference.

[052] The apparatus 100 is configured to receive and retain the closure element 500 such that the closure element 500 is disposed substantially within the apparatus 100. Thereby, if the apparatus 100 is introduced via an introducer sheath 640 (shown
10 in FIG. 8A), for example, the closure element 500 can be disposed within, and delivered by way of, a lumen 644 (shown in FIG. 8A) of the introducer sheath 640. The apparatus 100 also is configured to engage the blood vessel wall 620 adjacent to the opening 610. Being disposed substantially within the apparatus 100, the closure element 500 can deeply penetrate, without inadvertently contacting, tissue 630
15 adjacent to the opening 610 such that the apparatus 100 can position the closure element 500 substantially adjacent to an outer surface 620a (shown in FIG. 8A) of the blood vessel wall 620 adjacent to the opening 610.

[053] When properly positioned, the apparatus 100 can be activated to distally
20 deploy the closure element 500. Although preferably configured to substantially uniformly expand the closure element 500 beyond the natural cross-section 530 of the closure element 500 during deployment, the apparatus 100, as desired, can deploy the closure element 500 without expanding the closure element 500. The closure element 500, when deployed, is configured to engage significant amount of the blood vessel
25 wall 620 and/or tissue 630 adjacent to the opening 610. Engaging the blood vessel wall 620 and/or tissue 630, the closure element 500 is further configured to return to the natural cross-section 530. Thus, the engaged blood vessel wall 620 and/or tissue 630 are drawn substantially closed and/or sealed, such that, for example, hemostasis within the opening 610 is enhanced.

30

[054] The apparatus 100 can be provided as one or more integrated components and/or discrete components. As shown in FIGS. 1 and 2, for example, the apparatus 100 can include an elongated delivery assembly 200 having a distal locator (or

obturator) portion 202 and a carrier portion 300 that carries a closure element 500 thereon, in the reduced, substantially tubular configuration of FIGS. 8B-8E. For purposes of illustration, the locator portion 202 and the carrier portion 300 are shown in FIG. 1 as comprising substantially separate assemblies. As desired, however, the
5 locator portion 202 and the carrier portion 300 each can be provided, in whole or in part, as one or more integrated assemblies.

[055] Being configured to extend into the opening 610, the locator portion 202 can selectably engage the inner surface 620b of the blood vessel wall 620 adjacent to
10 the opening 610 (FIG. 8D). Thereby, the distal locator portion 202 is configured to draw the blood vessel wall 620 taut and can maintain the proper position of the apparatus 100 as the blood vessel 600 pulsates. The distal locator portion 202 can be provided in the manner disclosed in co-pending application Ser. Nos. 09/732,835 and 10/081,723, the disclosure of which is expressly incorporated herein by reference.
15 Further, the delivery assembly 200 preferably includes a flexible, semi-rigid tubular, or rigid body 210, such as an elongate rail, with a longitudinal axis 216. As illustrated in FIG. 4A, the tubular body 210 has a proximal end region 210a and a distal end region 210b that supports the distal locator portion 202 and the carrier portion 300.

[056] The tubular body 210 is preferably of a predetermined length 218a and a predetermined outer cross-section 218b (FIG. 2), both of which can be of any suitable dimension. The distal section of the distal locator portion 202 preferably includes a substantially rounded, soft, and/or flexible distal end or tip 220 to facilitate atraumatic advancement and/or retraction of the distal section into the blood vessel 600. As
25 desired, a pigtail (not shown) may be provided on the distal end 220 to further aid atraumatic advancement of the delivery assembly 200.

[057] The distal locator portion 202 further is selectably controllable between an unexpanded state (FIG. 4A) and an expanded state (FIG. 4B). In the unexpanded
30 state, the distal locator portion 202 has an unexpanded size; whereas, the distal locator portion 202 in the expanded state has an expanded size, which is greater than the unexpanded size of the distal locator portion 202 in the unexpanded state. The distal locator portion 202 is configured to expand from the unexpanded size to the expanded

size and/or to contract from the expanded size to the unexpanded size, and the expansion and contraction of the distal locator portion 202 preferably is substantially uniform about the longitudinal axis 216. For example, one or more expansion elements 230 can be provided on the distal locator portion 202 and can be configured to expand substantially transversely with respect to a longitudinal axis 216 of the locator portion 202. Preferably being substantially equally distributed about an outer periphery 212 of the distal locator portion 202, the expansion elements 230 may include radiopaque markers (not shown) or may be wholly or partially formed from a radiopaque material to facilitate observation of the expansion elements 230 and/or the distal locator portion 202 using fluoroscopy or other imaging systems.

[058] At least one, and preferably all, of the expansion elements 230 of the distal locator portion 202 can comprise a substantially flexible member 230' with a substantially fixed end region 230a', an intermediate region 230b', and a movable end region 230c' as shown in FIGS. 4A-4B. For each substantially flexible member 230', the proximal fixed end region 230a' is fixedly coupled, relatively, with an intermediary support region 211 separating the distal locator portion 202 from the carrier portion 300. In contrast, the movable end region 230c' is movably coupled, relatively, with the intermediary support region 211, and configured to be axially movable relative to the fixed end region 230a'. When each movable end region 230c' is axially moved toward the relevant fixed end region 230a', the intermediate regions 230b' buckle and/or expand transversely outwardly, thereby transitioning the distal locator portion 202 of the delivery assembly 200 from the unexpanded state to the expanded state. In contrast, the distal locator portion 202 transitions from the expanded state to the unexpanded state as each of the movable end regions 230c' are axially moved away from the relevant fixed end region 230a'.

[059] Hence, the expansion elements 230 are relatively resilient, and can buckle without plastic deformation or pure elastic deformation. Further, although the expansion elements 230 are shown as comprising the flexible members 230' in FIGS. 4A-4B for purposes of illustration, it is understood that the expansion elements 230 can comprise any type of expansion elements and are not limited to the illustrated embodiments. For example, inflatable bladder type devices or the like may be

employed to cause expansion of the expansion elements, such as a balloon, an expandable mesh or a slit hypotube, etc. In a preferred embodiment, the flexible members are constructed of nitinol.

5 [060] Turning to FIG. 4C, the locator portion 202 also can include a locator control system 240 that is coupled with the proximal end region 210a of the delivery assembly 200 and that is configured to selectively control the distal locator portion 202 between the unexpanded and expanded states. The locator control system 240 can selectively control the distal locator portion 202 between the unexpanded and
10 expanded states, such as by being activated by a switching system (not shown). For example, a control member 250, such as a rod, wire, or other elongate member, can be moveably disposed within a lumen (not shown) formed by the tubular body 210 and extending substantially between the proximal end region 210a of the tubular body 210 and the distal locator portion 202. The control member 250 has a proximal end region
15 250a that is coupled with the locator control system 240, preferably through a control block (not shown, but operationally similar to the control systems and structures), and a distal end section (not shown) of the control member 250 that is coupled with the expansion elements 230, and/or the movable end regions 230c' of the substantially flexible members 230'. The locator control system 240 can selectively transition the
20 expansion elements 230, and/or the substantially flexible members 230' of the distal locator portion 202 between the unexpanded and expanded states by moving the control member 250 axially relative to the tubular body 210.

[061] The locator control system 240 preferably includes a locator release system
25 (not shown, but one embodiment which may be similar to that disclosed in the '214 patent application) for maintaining the unexpanded state and/or the expanded state of the distal end region 210b, the expansion elements 230, and/or the substantially flexible members 230'. The locator release system is preferably configured to maintain the locator portion in the expanded state. Any type of locking system can be
30 employed, and can be engaged, for instance, by activating the switching system. For example, once the substantially flexible members 230' have entered the expanded state, the locator release system can secure the control member 250 to prevent axial movement relative to the tubular body 210, thereby maintaining the substantially

flexible members 230' in the expanded state.

[062] The locator control system 240 also can be configured to disengage the locator release system, such that the distal end region 210b, the expansion elements
5 230, and/or the substantially flexible members 230' can transition between the unexpanded and expanded states. The locator release system can be disengaged, for example, by activating an emergency release system (not shown). As desired, the locator control system 240 can further include a biasing system (not shown), such as one or more springs, to bias the distal end region 210b, the expansion elements 230,
10 and/or the substantially flexible members 230' to enter and/or maintain the unexpanded state when the locator release system 490 is disengaged.

[063] Referring back to FIGS. 1 and 4, the delivery assembly 200 also includes the carrier portion 300 positioned along the tubular body 210, and oriented adjacent
15 and proximate to the distal locator portion 202. The carrier portion 300 is configured to receive and retain the closure element 500 in the reduced, substantially tubular configuration (shown in FIG. 7B), which preferably is disposed substantially within and a cover member 330 of the carrier portion 300. When the locator portion 202 engages the inner surface 620b (shown in FIG. 8A) of the blood vessel wall 620, the
20 carrier portion 300 is further configured to position the closure element 500 substantially adjacent to the opening 610 and to deploy the closure element 500. Upon being deployed, the closure element 500 can maintain the reduced cross-section 530' (shown in FIG. 7C) but preferably can temporarily and substantially uniformly expand beyond the natural cross-section 530 (shown in FIGS. 8F and 8G) of the
25 closure element 500. In either case, the closure element 500, when deployed, can engage significant amount of the blood vessel wall 620 and/or tissue 630 adjacent to the opening 610. Thereafter, the closure element 500 is configured to return to the natural cross-section 530, preferably substantially uniformly, such that the blood vessel wall 620 and/or tissue 630 is drawn substantially closed and/or sealed (FIG.
30 8H).

[064] Turning now to FIGS. 5A-5C, the carrier portion 300 preferably includes a deployment device 302, a pusher member 320, and the cover member 330. The

carrier portion 300, the pusher member 320 and the cover member 330 can be provided as a plurality of nested, telescoping members with a common longitudinal axis 350 of the tubular as illustrated in FIG. 5A. The deployment device 302 is configured to receive and support the closure element 500. While being disposed on the carrier portion 300, the closure element 500 preferably is deformed from the natural, planar configuration to form the substantially tubular closure element 500" (shown in FIGS. 3F-3G) as will be discussed in more detail below. Being disposed substantially about, and supported by, an outer periphery 312 of the deployment device 302, the closure element can be radially reduced in size and retained in place (FIGS. 8B-8E). In this arrangement, the substantially tubular closure element 500" can be substantially in axial alignment therewith with the tines 520 pointed substantially distally.

[065] A biocompatible glue or adhesive may be applied to retain the resilient closure element 500" on the unexpanded deployment device 302 and loaded for deployment, in the reduced, substantially tubular configuration. Together with the compression properties of the cover member 330, the glue or adhesive must be sufficient to overcome the resilient tendency of the closure member 500" (FIG. 3G) to return to its natural planar condition 500 (FIGS. 3A and 3B). By way of example, such glues and embedded adhesives include polymer coatings, Loctite, etc. It will further be appreciated that other techniques can be applied to retain the closure element 500, in the reduced, substantially tubular configuration about the unexpanded deployment device 302.

[066] As illustrated in FIGS. 4A and 4B, the deployment device 302 that supports the closure element 500 is configured to uniformly radially expand the reduced, substantially tubular closure element 500" beyond the natural cross-section 530 of the closure element 500 to prepare the substantially tubular closure element 500" for deployment (FIGURE 8K). In some instances, however, the closure element 500 may be deployed without expanding the closure element 500. Thus, in this configuration, the carrier portion 300 will not be moved to the expanded position, maintaining a cross-section (not shown) that is substantially uniform and equal of that to the unexpanded distal locator portion 202. Accordingly, although shown and described as

having the cross-section that increases distally for expanding the substantially tubular closure element 500", it will be understood that the carrier portion 300 can be provided with the substantially-uniform cross-section and that the substantially tubular closure element 500" can be deployed without being expanded.

5

[067] Referring back to FIGS. 4A and 4B, in one specific embodiment, the expandable deployment device 302 of the carrier portion 300 is structurally similar to the expandable distal locator portion 202. Similar to the distal locator portion 202, the deployment device 302 is selectably controllable between an unexpanded state (FIG. 10 4A) and an expanded state (FIG. 4B). In the unexpanded state, the deployment device 302 has an unexpanded size that carries and supports the closure element 500" thereon, in the reduced, substantially tubular configuration shown in FIGS. 3G and 7C. The deployment device 302 in the expanded state has an expanded size, which is greater than the unexpanded size of the deployment device 302 in the unexpanded 15 state. The deployment device 302 is configured to expand from the unexpanded size to the expanded size and/or to contract from the expanded size to the unexpanded size, and the expansion and contraction of the deployment device 302 preferably is substantially uniform about the longitudinal axis 350, which incidentally when aligned with the distal locator portion 202, is substantially coaxial with its longitudinal axis 20 216. In the fully expanded state, the deployment device causes the closure element 500" to substantially uniformly expand to an expanded cross-sectional dimension (FIG 8K) that is greater than a natural cross-sectional dimension (FIG. 3A).

[068] More specifically, in one configuration, the deployment device is very 25 similar to the distal locator portion 202 (or distal obturator) in that the deployment device 302 itself is in the form of a proximal obturator. As shown in FIG. 4B, the proximal obturator may include one or more expansion elements 304 that are configured to expand substantially transversely with respect to a longitudinal axis 350 of the carrier portion 300. Preferably being substantially equally distributed about an 30 outer periphery 312 of the proximal obturator 302, the expansion elements 304 may similarly include radiopaque markers (not shown) or may be wholly or partially formed from a radiopaque material to facilitate observation of the expansion elements 304 and/or the proximal obturator 302 using fluoroscopy or other imaging systems.

[069] At least one, and preferably all, of the expansion elements 304 of the proximal obturator 302 can comprise a substantially flexible member 304' with a substantially fixed end region 304a', an intermediate region 304b', and a movable end region 304c' as shown in FIGS. 4A and 4B. In contrast to the distal obturator 202, for each substantially flexible member 304', the fixed end region 304a' is oriented at distal end region 302b of the deployment device 302. The expansion elements fixed end region 304a' is fixedly coupled, relatively, to a proximal end of the intermediary support region 211 which incidentally is also fixedly coupled to a proximal end region 202a of the distal locator portion 202. The proximal movable end region 304c' of the flexible members 304', by comparison, is movably coupled with respect to the proximal end region 302a of the proximal obturator 302, and is configured to be axially movable relative to the fixed end region 304a'. This configuration enables the distal obturator to maintain a fixed relation to the vessel wall 620 when the distal locator portion 202 is in the expanded state, and the proximal obturator 302 is being operated.

[070] When each movable proximal end region 304c' of the respective flexible member is axially moved toward the relevant fixed distal end region 304a', the intermediate regions 304b' buckle and/or expand transversely outwardly, thereby transitioning the proximal obturator 302 of the delivery assembly 200 from the unexpanded state to the expanded state. This causes the closure element 500" to expand toward the expanded substantially tubular configuration (FIG. 8G), spreading the opposed tines 520 during deployment to enable engagement with a wider area of the tissue 630 and/or blood vessel 600. Moreover, the closure element may also be caused to move closer to the distal locator portion 202. By comparison, the proximal obturator 302 transitions from the expanded state to the unexpanded state as each of the movable end regions 304c' are axially moved away from the relevant fixed end region 304a'.

30

[071] Although the expansion elements 304 are shown as comprising the flexible members 304' in FIGS. 4A-4B for purposes of illustration, it is understood that the expansion elements 304 can also comprise any type of expansion elements and are not

limited to the illustrated embodiments. As mentioned above, the expansion elements can be provided by inflatable bladder type devices or the like as well, such as a balloon, an expandable mesh or a slit hypotube, etc.

5 [072] Similar to the locator portion, the carrier portion can also include a carrier control system 306 (FIG. 4C) that is coupled with the proximal end region 210a of the tubular body 210 of the delivery assembly 200, and that is configured to selectively control the proximal obturator 302 between the unexpanded and expanded states. The carrier control system 306 can selectively control the proximal obturator 302 between
10 the unexpanded and expanded states, such as by being activated by a switching system (not shown). For example, a carrier control member 308 (adjacent locator control member 250), such as a rod, wire, or other elongate member, can be moveably disposed within a lumen (not shown) formed by the tubular body 210 and extending substantially between the tubular body proximal end region 210a and the proximal
15 obturator 302. The carrier control member 308 includes a proximal end region 308a that is coupled to the carrier control system 306, preferably through a control block (not shown, but operationally similar to the control systems and structures described in the '214 Patent Application), and a distal end section (not shown) that is coupled to the expansion elements 304, and/or the movable end regions 304c' of the substantially
20 flexible members 304'. The carrier control system 306 can selectively transition the expansion elements 304, and/or the substantially flexible members 304' of the proximal obturator 302 between the unexpanded and expanded states by moving the control member 308 axially relative to the tubular body 210.

25 [073] The carrier control system 306 preferably includes a carrier release system (not shown) for maintaining the unexpanded state and/or the expanded state of the expansion elements 304, and/or the substantially flexible members 304' of the proximal obturator 302. While the release system is not shown, one similar to the locator release system above-mentioned, and as described in the '214 Patent
30 Application may be provided.

[074] The carrier control system 306 also can be configured to disengage the carrier release system, such that the expansion elements 304, and/or the substantially

flexible members 304' can transition between the unexpanded and expanded states. The carrier release system can be disengaged, for example, by activating an emergency release system (not shown). As desired, the carrier control system 306 can further include a biasing system (not shown), such as one or more springs, to bias the expansion elements 304, and/or the substantially flexible members 304' to enter and/or maintain the unexpanded state when the carrier release system is disengaged.

[075] Referring now to FIGS. 5A and 5B, when the substantially tubular closure element 500" is deployed, the pusher member 320 has a proximal end region 320a and a distal end region 320b and is coupled with, and slidable relative to, the carrier portion 300. The pusher member 320 includes a predetermined length 328a and a predetermined cross-section 328b, both of which can be of any suitable dimension. The pusher member is further configured to slidably receive at least a portion of the deployment device 302, as well as the tubular body 210 therein, such that the distal end region 320b of the pusher member 320 is axially offset proximally from the distal end region 302b of the deployment device 302. This axial offset, hence, defines a space 360 that permits the positioning of the substantially tubular closure element 500" about the proximal obturator or deployment device 302.

[076] The predetermined length 328a of the pusher member 320 can be greater than or substantially equal to the collective predetermined length 218a of the tubular body 210 and the carrier portion 300. The predetermined length 328a of the pusher member 320 however is preferably less than the collective predetermined length 218a of the tubular body 210 and the deployment device 302. In this manner, the deployment device 302 and the pusher member 320 at least partially define the space 360 distal to the distal end region 320b of the pusher member 320 and along the periphery 312 of the deployment device 302.

[077] Being formed from a substantially rigid, semi-rigid, or flexible material, the pusher member 320 preferably is substantially tubular and can define a lumen 324 that extends substantially between the proximal end region 320a and the distal end region 320b. This lumen 324 is configured to slidably receive at least a portion of the tubular body 210 and the deployment device 302 therethrough. The cross-section 328b of the

pusher member 320 preferably is substantially uniform, and the distal end region 320b of the pusher member 320 can comprise one or more longitudinal extensions 325, which extend distally from the pusher member 320 and along the periphery 312 of the deployment device 302, as shown in FIG. 5B. The longitudinal extensions 325
5 preferably are biased such that the longitudinal extensions 325 extend generally in parallel with common longitudinal axis 350. The longitudinal extensions 325 are sufficiently flexible to expand radially, and yet sufficiently rigid to inhibit buckling. Hence, to deploy the substantially tubular closure element 500" as the deployment device selectively expands from the unexpanded state to the expanded state, the distal
10 end region 320b of the pusher member is directed distally along the deployment device 302 and engages the distally-increasing cross-section of the distal end region 302b of the deployment device 302.

[078] As best shown in FIGS. 5A and 7C, the cover member 330 is configured to
15 retain the substantially tubular closure element 500" and the carrier portion 300 substantially within a lumen 334 thereof prior to deployment. Being coupled with, and slidable relative to, the deployment device 302 and the pusher member 320, the cover member 330 has a proximal end region 330a and a distal end region 330b and includes a predetermined length 338a and a predetermined cross-section 338b, both of
20 which can be of any suitable dimension. Preferably being formed as a substantially rigid, semi-rigid, or flexible tubular member formed from a polymer, the cover member 330 has an outer periphery 332b and an inner periphery 332a that defines lumen 334. The lumen 334 extends substantially between the proximal and distal end regions 330a, 330b of the cover member 330 and can be configured to slidably receive
25 at least a portion of the pusher member 320. When the cover member 330 is properly positioned over the pusher member 320 and the deployment device 302, the distal end region 330b is configured to extend over the space 360, thereby defining an annular cavity 370 for receiving and retaining the closure element 500" in the reduced, substantially tubular configuration.

30

[079] The cross-section 338b of the cover member 330 preferably is substantially uniform, and the distal end region 330b of the cover member 330 preferably comprises one or more longitudinal extensions 335, which extend distally from the

cover member 330 and along an outer periphery 322b of the pusher member 320 as shown in FIG. 5C. Although the longitudinal extensions 335 can extend generally in parallel with common longitudinal axis 350, the longitudinal extensions 335 preferably are biased such that the plurality of longitudinal extensions 335 extend substantially radially inwardly as illustrated in FIGS. 5A and 5C. Thereby, the longitudinal extensions 335 can at least partially close the lumen 334 substantially adjacent to the distal end region 330b of the cover member 330. To permit the substantially tubular closure element 500" to be deployed from the annular cavity 370, the cover member 330 can be slideably retracted, relative the deployment device 302 to expose the mounted closure element 500". The longitudinal extensions 335 of the cover member 330 preferably are sufficiently flexible to expand radially to permit retractive movement of the distal end region 330b of the cover member 330 peripherally over the deployment device 302 and mounted closure element 500". This opens the annular cavity 370 such that the distal end region 330b of the cover member 330 no longer extends over the space 360.

[080] If the carrier portion 300 is assembled as the plurality of nested, telescoping members as shown in FIG. 5A, the deployment device 302 and the tubular body 210 of the delivery assembly are at least partially disposed within, and slidable relative to, the lumen 324 of the pusher member 320. The pusher member 320, in turn, is at least partially disposed within, and slidable relative to, the lumen 334 of the cover member 330. Hence, the longitudinal axis 216 of the locator portion 202, the carrier portion 300 and the tubular body 210 (i.e., of the delivery assembly 200) are preferably substantially in axial alignment with the common longitudinal axis of the pusher member 320 and the cover member 330.

[081] FIG. 6 best illustrates that the clip applier apparatus 100 includes a housing/handle 380 at a proximal end thereof suitable for gripping and manual support, manipulation and operation of the device and components thereof. Preferably, the housing is an elongated member with a longitudinal axis 386. When the apparatus 100 is properly assembled, the tube set 305 of the delivery assembly 200 is at least partially disposed within the housing handle such that the pusher member 320 and the cover member 330 are slidable relative to, the housing 380, and the

tubular body, the carrier portion 300 and the distal locator portion 202 thereof. Further, respective distal end regions 210b, 320b and 330b extend from the distal end region 380b of the housing 380 such that the common longitudinal axis 350 (shown in FIG. 5A) of the tube set 305 is substantially axially aligned with the longitudinal axis 386 of the housing 380. Being configured to slidably retain the respective proximal end regions 210a, 320a and 330a, the housing 380 supports the tube set 305 and can have one or more handles 390 to facilitate use of the apparatus 100. The handles 390 extend substantially radially from the outer periphery 382 of the housing 380 and can be provided in the manner known in the art.

10

[082] The present invention incorporates various switching systems, triggering systems, locking systems, etc. contained in the handle portion to effect use and operation of the delivery components described herein. While these subsystems are not shown and described herein in detail, it will be appreciated that they are similar to the design and operation of the analogous subsystems shown and described in our '214 Patent Application, which as mentioned is incorporated by reference herein for all purposes.

[083] In use, the closure element 500' is carried on the deployment device 302, and disposed within the cover member 330. As shown in FIGS. 7A-7B, for example, the reduced closure element 500' can be slidably received over the distal locator portion 202 and the distal end region 300b of the carrier portion 300. The closure element 500' in the substantially tubular configuration is then seated and disposed about the periphery 312 of the deployment device 302 (e.g., the expansion elements 304 of the proximal obturator 302 in the unexpanded state) adjacent to the space 360.

[084] To retain the reduced closure element 500' in the tubular configuration about the periphery of the carrier portion 300, the reduced diametric cross-section 530' of the reduced closure 500' is slightly less than or equal to the diametric cross-section 318b of the expansion elements 304 in the unexpanded state. Thus, to position the reduced closure element 500' on the deployment device 302, the reduced closure element 500' is temporarily radially deformed for receipt over the distal end region 302b of the deployment device 302. In addition, as the reduced closure element 500'

30

is received over the distal end region 302b, the opposing tines 520 of the reduced closure element 500' engage the distal end region 302b. The reduced closure element 500' thereby forms the substantially tubular closure element 500" in the manner described in more detail above with reference to FIGS. 3E-3G.

5

[085] After being received over the distal end region 302b, the substantially tubular closure element 500" is disposed about the space 360, and the tines 520 are directed substantially distally as shown in FIG. 7B. To improve the engagement between the closure element 500 (shown in FIGS. 3A-3B) and the blood vessel wall 10 620 and/or tissue 630 (collectively shown in FIG. 8A), the substantially tubular closure element 500" preferably is disposed on the deployment device 302 such that the tines 520 are contained in a plane.

[086] Once disposed about the space 360, and together with the aforementioned 15 glue or adhesive, the reduced, substantially tubular closure element 500" can be retained on the outer periphery 312 of the deployment device 302 when the distal end region 302b thereof and the distal end region 320b of the pusher member 320 are slidably received within the lumen 334 of the cover member 330 as illustrated in FIGS. 7B and 7C. When the cover member 330 is properly positioned over the carrier 20 portion 300, the distal end region 330b of the cover member 330 extends over the space 360 and defines the annular cavity 370 for retaining the substantially tubular closure element 500". As such, the substantially tubular closure element 500" is disposed substantially between the outer periphery 312 of the delivery device 302 and the inner periphery 332a of the cover member 330 such that the substantially tubular 25 closure element 500" maintains the substantially tubular configuration with the tines 520 being directed substantially distally. As desired, the tube set 305 may radially compress the substantially tubular closure element 500" such that the substantially tubular closure element 500" enters and maintains a compressed tubular configuration. The body 510 of the substantially tubular closure element 500" can be disposed 30 distally of the distal end region 320b of the pusher member 320, as illustrated in FIGS. 7C, or can engage the distal end region 320b, as desired.

[087] Turning now to FIG. 8A, an introducer sheath 640 may be inserted or otherwise positioned through skin 650 and tissue 630 and within the blood vessel 600 or other body lumen via the opening 610. Comprising a substantially flexible or semi-rigid tubular member, the sheath 640 has a proximal end region 640a and a distal end region 640b and includes a predetermined length and a predetermined cross-section, both of which can be of any suitable dimension. The sheath 640 also forms a lumen 644 that extends along a longitudinal axis of the sheath 640 and substantially between the proximal and distal end regions 640a, 640b. The lumen 644 can have any suitable internal cross-section 648b and is suitable for receiving one or more devices (not shown), such as a catheter, a guide wire, or the like. The lumen 644 is configured to slidably receive tube set 305 and the delivery assembly 200 of the apparatus 100, including the nested tubular body 210, the deployment device 302, the distal locator portion 202, pusher member 320 and the cover member 330 as a single unit. Accordingly, one significant advantage of the present invention is that, due to the reduced complexity of the cooperating componentry, the overall diametric footprint can be significantly smaller relative to the current systems. Hence, the entire nested tube set 305 may be slidably received in the lumen 644 of the introducer sheath 640 without requiring a radial expansion or splitting of the sheath 640. Such a configuration is beneficial in that, when required, the delivery assembly 200 can be retracted and reinserted unlike the previous designs that irreversibly radially expanded, stretched, split or severed the analogous sheaths.

[088] The sheath 640 may be advanced over a guide wire or other rail (not shown) that was previously positioned through the opening 610 and into the blood vessel 600 using conventional procedures. In one specific use, the blood vessel 600 is a peripheral blood vessel, such as a femoral or carotid artery, although other body lumens may be accessed using the sheath 640 as will be appreciated by those skilled in the art. The opening 610, and consequently the sheath 640, may be oriented with respect to the blood vessel 600 such as to facilitate the introduction of devices through the lumen 644 of the sheath 640 and into the blood vessel 600 with minimal risk of damage to the blood vessel 600. One or more devices (not shown), such as a catheter, a guide wire, or the like, may be inserted through the sheath 640 and advanced to a predetermined location within the patient's body. For example, the devices may be

used to perform a therapeutic or diagnostic procedure, such as angioplasty, atherectomy, stent implantation, and the like, within the patient's vasculature.

[089] After the procedure is completed, the devices are removed from the sheath 5 640, and the apparatus 100 is prepared to be received by the lumen 644 of the sheath 640 as shown in FIG. 8B. Being in the unexpanded state, the distal end region 202b of the distal locator portion, via tubular body 210, is slidably received by the lumen 644 and atraumatically advanced distally into the blood vessel 600 (FIG. 8B). Briefly, it will be appreciated that, due to the fixed configuration between the distal end region 10 300b of the carrier portion 300 and the proximal end region 202a of the distal locator portion 202, in a support configuration, that the deployment device 302, the pusher member 320 and the cover member 330, together with the closure element in the reduced, substantially tubular configuration, are also advanced distally near the blood vessel 600 as a unit. Moreover, since the pusher member 320 and the cover member 15 are also coupled to the tubular body 210, those components are likewise advanced distally together with the locator portion 202. Once the distal end region 202b of the distal locator portion 202 extends into the blood vessel 600, the distal locator portion 202 can transition from the unexpanded state to the expanded state as shown in FIG. 8C by activating the switching system of the locator portion 202.

20

[090] Turning now to FIG. 8D, the apparatus 100 and the sheath 640 then are retracted proximally until the distal end region 202b of the locator portion 202 is substantially adjacent to an inner surface 620b of the blood vessel wall 620. The distal end region 202b of the locator portion 202 thereby draws the blood vessel wall 25 620 taut and maintains the proper position of the apparatus 100 as the blood vessel 600 pulsates. Since the expanded cross-section of the distal end region 202b is greater than or substantially equal to the cross-section of the opening 610 and/or the cross-section of the lumen 644, the distal end region 202b remains in the blood vessel 600 and engages the inner surface 620b of the blood vessel wall 620. The distal end 30 region 202b can frictionally engage the inner surface 620b of the blood vessel wall 620, thereby securing the apparatus 100 to the blood vessel 600. The sheath 640 is retracted proximally such that the distal end region 640b of the sheath 640 is substantially withdrawn from the blood vessel 600, as shown in FIG. 8D, permitting

the apparatus 100 to access the blood vessel wall 620.

[091] As above-mentioned, the relative distance between the distal end region 300b of the carrier portion 300 and the proximal end region 202a of the distal locator portion 202 is fixed. Hence, once the distal end region 202b of the locator portion 202 properly engages the inner surface 620b of the blood vessel wall 620 as the expansion elements 230 are selectively positioned and moved to the expanded state, the carrier portion 300 is simultaneously axially positioned adjacent the opening 610, at a first predetermined position (FIG. 8D), where the closure element 500" can be prepared for deployment. More particularly, upon establishing the first predetermined position, the deployment device 302 and the loaded reduced closure element 500", in the reduced, substantially tubular configuration, are disposed proximal and substantially adjacent to the outer surface 620a of the blood vessel wall 620. In this manner, the blood vessel wall 620, adjacent to the opening 610, is disposed substantially between the expanded distal region 202b of the locator portion 202 and the distal end region 300b of the carrier portion 300.

[092] Once the first predetermined position is established, the carrier portion 300 can be manipulated to deploy the closure element. Initially, the cover member 330 is proximally retracted to a pre-deployment position, relative to the distal locator portion 202, the deployment device 302 and the pusher member 320, which are to remain axially substantially stationary, in order to expose at least a portion of the closure element. This is performed by decoupling the cover member 330 from the deployment device 302, the distal locator portion 202, and the pusher member 320, all of which are preferably inhibited from axial relative movement.

[093] As best shown in FIG. 8E, as the cover member 330 is retracted proximally, relative the carrier portion 300, toward the pre-deployment configuration, the distal end region 300b of the cover member 330 moves proximally such that the cover member 330 no longer encloses the annular cavity 370. In this configuration, the space 360 and at least a portion of the closure element 500" (e.g., the tines 520) are exposed through an opening into lumen 334 of the cover member 330. Thereby, the substantially tubular closure element 500" is not completely enclosed by the annular

cavity 370 formed by the distal end regions 320b and 330b of the pusher member 320 and the cover member 330, respectively.

5 [094] Although not completely enclosed by the annular cavity 370, the substantially tubular closure element 500" is advantageously retained on the outer periphery 312 of the deployment device 302 by the distal end region 330b of the cover member 330 as illustrated in FIG. 8E. For example, the longitudinal extensions 335 of the cover member 330 resiliently contact at least a portion of the closure element, in the reduced tubular configuration, by an amount sufficient to maintain the closure
10 element 500" on the deployment device 302 during movement thereof from the unexpanded state to the expanded state. By retaining the proximal portion of the substantially tubular closure element 500" between the distal end region 330b (e.g., the radially, inwardly directed longitudinal extensions 335) of the cover member 330 and the distal end region 202b of the deployment device 302, the apparatus 100 is
15 configured to provide better tissue penetration for the closure element 500".

[095] Moreover, the timing between the deployment of the substantially tubular closure element 500" by the carrier portion 300, and the retraction and transition to the unexpanded state by the locator portion 202 and the deployment device 302 likewise
20 are facilitated because the substantially tubular closure element 500" is retained between the cover member distal end region 330b and the deployment device distal end region 202b. Further, the deployment device 302 and the cover member 330 operate to maintain the substantially tubular closure element 500" in the tubular configuration.

25

[096] Referring back to FIG. 8E, once the cover member 330 is properly retracted to expose the tines 520 of the closure member 500", in the pre-deployment configuration, the cover member is recoupled to the delivery assembly 200 so as to be maintained axially substantially stationary relative the deployment device 302 and the
30 distal locator portion 202. The deployment device 302 can then transition from the unexpanded state to the expanded state, as shown in FIG. 8F, by activating the switching system of the carrier portion 300. This causes the closure element 500", in the reduced substantially tubular configuration, to expand radially outward toward the

expanded substantially tubular configuration for deployment thereof.

[097] In one embodiment where the deployment device 302 is in the form of a proximal obturator, by way of example, when the switching system is actuated, the wire 308 (FIGURE 4C) causes the movable expansion elements 304 to retract, thereby collectively radially expanding the expansion elements 304. Since portions of the closure element 500" (E.g., the tines 520) are adhered and/or resiliently retained about the periphery 312 of the expansion elements 304 of the deployment device 302, as the expansion elements 304 move toward the expanded state, the closure element 500" is caused to radially expand. In particular, the cross-section 530' (shown in FIGS. 3F-3G) of the reduced, substantially tubular closure element 500" begins to radially expand, preferably in a substantially radially uniform manner with the expansion of the deployment device to the expanded state (FIG. 8F).

[098] By axially positioning the distal tips of the tines 520 of the closure element 500" at or near the region of greatest radial expansion of the expansion elements 304, such as for example the intermediate regions 304b' of the substantially flexible members 304' of the proximal obturator 302, the distal tips of the tines are caused to be radially displaced outward at least as much as any other portion of the closure element in the tubular configuration. As the expansion elements 304 of the deployment device 302 are caused to fully expand, in the expanded state, the distal tips of the closure element tines 520 are oriented in a direction radially outward from the longitudinal axis 350 of the deployment device to increase the area of tissue engagement. Further, the cross-section 530' of the substantially tubular closure element 500" radially expands beyond natural cross-section 530 (shown in FIGS. 3A-3B) of the closure element 500, placing the tube set in condition to deploy the closure element 500" (FIG. 8F).

[099] Once the carrier portion 300 is moved to the expanded state, a lock system of the carrier portion may retain the expansion elements 304 in the expanded state for deployment of the closure element. To deploy the closure element 500" in the expanded substantially tubular configuration, the pusher member 320 decouples from the delivery assembly 200 and the cover member 330. Therefore, the carrier portion

300, the locator portion 202 and the cover member 330 preferably are inhibited from further axial movement and remain substantially stationary, relative the handle portion; whereas, the pusher member 320 remains axially slidable.

5 [0100] As the pusher member 320 selectively continues distally, the distal end region 320b of the pusher member 320 engages the substantially tubular closure element 500" and displaces the substantially tubular closure element 500" from the space 360. Since the space 360 is substantially radially exposed, the pusher member 320 directs the substantially tubular closure element 500" over the expanded cross-
10 section of the deployment device expansion elements 304 such that the cross-section 530' (shown in FIGS. 3F-3G) of the substantially tubular closure element 500" continues to radially expand, preferably in a substantially uniform manner. As the substantially tubular closure element 500" traverses over the expanded cross-section of the deployment device expansion elements 304, in the expanded state, the closure
15 element is advanced distally and completely out of the radially inward grasp of the distal end region 300b of the cover member 330. Further, the cross-section 530' of the substantially tubular closure element 500" radially expands beyond natural cross-section 530 (shown in FIGS. 3A-3B) of the closure element 500. As mentioned and as shown in FIG. 8F, in some configurations, the tips of the distally facing tines 520
20 may be directed radially outward, enabling the closure element to engage a larger area of tissue.

[0101] Upon being directed over the distally-increasing cross-section of the expansion elements 304 of deployment device 302 by the pusher member 320, the
25 substantially tubular closure element 500" is distally deployed as illustrated in FIG. 8G. When the substantially tubular closure element 500" is deployed, the tines 520 can pierce and otherwise engage significant amount of the blood vessel wall 620 and/or tissue 630 adjacent to the opening 610. For example, the tines 520 can engage significant amount of the blood vessel wall 620 and/or tissue 630 because the cross-
30 section 530' of the substantially tubular closure element 500" is expanded beyond natural cross-section 530 of the closure element 500 during deployment.

[0102] The proximal end region 202a of the locator portion 202 also begins to retract proximally and a locator release system (not shown) can be activated to transition from the expanded state to the unexpanded state as the substantially tubular closure element 500" is deployed as shown in FIG. 8G. Simultaneously, the distal end region 300b of the carrier portion 300 also begins to retract proximally and a carrier release system (not shown) can be activated to transition from the expanded state to the unexpanded state. Preferably, the distal end regions 202b, 300b of the locator portion 202 and carrier portion 300 retract proximally and transition from the expanded state to the unexpanded state substantially simultaneously with the deployment of the substantially tubular closure element 500".

[0103] As desired, the distal end region 210b of the tubular body 210 may be configured to draw the blood vessel wall 620 and/or tissue 630 adjacent to the opening 610 proximally and into the channel 540 defined by the substantially tubular closure element 500". The tines 520 of the substantially tubular closure element 500" thereby can pierce and otherwise engage the drawn blood vessel wall 620 and/or tissue 630. Since the cross-section 530' of the substantially tubular closure element 500" is expanded beyond natural cross-section 530 of the closure element 500, a significant amount of the blood vessel wall 620 and/or tissue 630 can be drawn into the channel 540 and engaged by the tines 520.

[0104] Turning to FIG. 8H, the substantially tubular closure element 500", once deployed, begins to transition from the tubular configuration, returning to the natural, planar configuration with opposing tines 520 and a natural cross-section 530 of the closure element 500. Preferably, the substantially tubular closure element 500" substantially uniformly transitions from the tubular configuration to the natural, planar configuration. Rotating axially inwardly to form the opposing tines 520 of the closure element 500, the tines 520 draw the tissue 630 and/or vessel wall 620 into the channel 540 as the substantially tubular closure element 500" forms the closure element 500. In addition, the tissue 630 is drawn substantially closed and/or sealed as the cross-section 530' of the substantially tubular closure element 500" contracts to return to the

natural cross-section 530 of the closure element 500. Thereby, the opening 610 in the blood vessel wall 620 can be drawn substantially closed and/or sealed via the closure element 500 as illustrated in FIG. 8I.

5 [0105] The invention is susceptible to various modifications, alternative forms and uses, and specific examples thereof have been shown by way of example in the drawings and are herein described in detail. For instance, while the present invention has been primarily described for use in vessel closure, it will be appreciated that the present invention may be suitable for other repair applications as well, such as for
10 patent foramina ovalia (PFO) application. Other modifications may include a guide wire lumen so that the distal ends may be positioned over a guide wire as well. It should be understood, however, that the invention is not to be limited to the particular forms or methods disclosed, but to the contrary, the invention is to cover all modifications, equivalents, and alternatives falling within the spirit and scope of the
15 claims.

WHAT IS CLAIMED IS:

1. An apparatus for delivering and deploying a resilient closure element to an opening formed in a body lumen, said closure element being configured to resiliently deform between a natural, substantially planar configuration to a substantially tubular configuration, and further configured to substantially radially displace between a reduced substantially tubular configuration and an expanded substantially tubular configuration having a greater cross-sectional dimension, said apparatus comprising:
 - a delivery assembly positionable through said tissue and into said opening in the body lumen, and having a distal locator portion and a carrier portion oriented proximal to said distal locator portion, said distal locator portion being configured to selectably engage said body lumen adjacent to said opening, and said carrier portion being configured to carry and support said closure element, in the reduced substantially tubular configuration, and further configured to urge said closure element toward the expanded substantially tubular configuration for deployment thereof,
 - wherein said closure element is oriented to engage said tissue when deployed in the expanded substantially tubular configuration, and to return toward said natural, substantially planar configuration such that the engaged tissue is drawn substantially closed.
2. The apparatus of claim 1, further including:
 - a cover member protecting said delivery assembly such that at least said carrier portion and said closure element, in the reduced substantially tubular configuration, are fully contained therein, in a support configuration.
3. The apparatus of claim 2, wherein
 - said cover member defines a lumen sized and dimensioned for relative axial sliding receipt of said delivery assembly therein from the support configuration to a pre-deployment configuration, exposing at least a distal portion of said closure element to enable radial expansion thereof by said carrier portion from the reduced in the reduced substantially tubular configuration to the expanded substantially tubular configuration, for deployment thereof.

4. The apparatus of claim 3, wherein
a distal portion of said cover member is biased and tapered radially inward.
5. The apparatus of claim 4, wherein
5 said distal portion of said cover member includes a plurality of substantially resilient extension members tapered radially inward.
6. The apparatus of claim 5, wherein
in said pre-deployment configuration, each extension member is configured to
10 retain at least a proximal portion of the closure element against the carrier portion as said carrier portion is selectably moved from an unexpanded state to an expanded state urging said closure element from the reduced substantially tubular configuration to the expanded substantially tubular configuration, for deployment thereof.
- 15 7. The apparatus of claim 6, wherein
said carrier portion includes one or more expansion elements configured to expand substantially transversely with respect to a longitudinal axis of the carrier portion.
- 20 8. The apparatus of claim 1, wherein
said distal locator portion includes a distal obturator selectably controllable between an unexpanded state and an expanded state for engaging said body lumen.
9. The apparatus of claim 8, wherein
25 in said unexpanded state, said distal locator portion has a transverse cross-sectional dimension less than that of said opening, and
in said expanded state, said distal locator portion has a transverse cross-sectional dimension greater than or substantially equal to that of said opening.
- 30 10. The apparatus of claim 8, wherein
said distal obturator includes one or more expansion elements configured to expand substantially transversely with respect to a longitudinal axis of the distal locator portion.

11. The apparatus of claim 8, further including:
a locator control system coupled to a proximal end region of said delivery assembly, said locator control system being configured to selectively control said
5 distal locator portion between said expanded state and said unexpanded state.
12. The apparatus of claim 1, wherein
said carrier portion includes a proximal obturator selectably controllable
between an unexpanded state and an expanded state urging said closure element from
10 the reduced substantially tubular configuration to the expanded substantially tubular
configuration, for deployment thereof.
13. The apparatus of claim 12, wherein
said proximal obturator includes one or more expansion elements configured
15 to expand substantially transversely with respect to a longitudinal axis of the carrier
portion.
14. The apparatus of claim 13, further including:
a carrier control system coupled to a proximal end region of said delivery
20 assembly, said carrier control system being configured to selectively control said
carrier portion between said expanded state and said unexpanded state.
15. The apparatus of claim 2, further including:
a pusher member slideably disposed within said cover member, said pusher
25 member including a contact end region configured to distally displace said closure
member longitudinally along said delivery assembly.
16. The apparatus of claim 15, wherein
said delivery assembly, said pusher member and said cover member are
30 provided as a plurality of nested, telescoping members with a substantially common
longitudinal axis.

17. The apparatus of claim 16, wherein

said contact end region of said pusher member includes one or more longitudinal extensions extending distally and being configured to expand radially as said distal end region of said pusher member moves distally and engages a distally-
5 increasing transverse cross-sectional dimension of said carrier portion.

18. A system for closing an opening formed in a body lumen, comprising:

a substantially resilient closure element configured to resiliently deform between a natural, substantially planar configuration to a substantially tubular
10 configuration, and further configured to substantially radially displace between a reduced substantially tubular configuration and an expanded substantially tubular configuration, having a greater cross-sectional dimension, said apparatus comprising:

a delivery assembly positionable through said tissue and into said opening in the body lumen, and having a distal locator portion and a carrier portion oriented
15 proximal to said distal locator portion, said distal locator portion being configured to selectably engage said body lumen adjacent to said opening, and said carrier portion being configured to carry and support said closure element, in the reduced substantially tubular configuration, and further configured to urge said closure element toward the expanded substantially tubular configuration for deployment
20 thereof; and

a cover member protecting said delivery assembly such that at least said carrier portion and said closure element, in the reduced substantially tubular configuration, are fully contained therein, in a support configuration.

. wherein said closure element is oriented to engage said tissue when deployed
25 in the expanded substantially tubular configuration, and to return toward said natural, substantially planar configuration such that the engaged tissue is drawn substantially closed.

19. The system of claim 18, wherein

30 said cover member defines a lumen sized and dimensioned for relative axial sliding receipt of said delivery assembly therein from the support configuration to a pre-deployment configuration, exposing at least a distal portion of said closure element to enable radial expansion thereof by said carrier portion from the reduced in

the reduced substantially tubular configuration to the expanded substantially tubular configuration, for deployment thereof.

20. The system of claim 19, wherein

5 said distal portion of said closure element includes two or more tines distally directed, in the substantially tubular condition.

21. The system of claim 20, wherein

a distal portion of said cover member is biased and tapered radially inward.

10

22. The system of claim 21, wherein

said distal portion of said cover member includes a plurality of substantially resilient extension members tapered radially inward.

15 23. The system of claim 22, wherein

in said pre-deployment configuration, each extension member is configured to retain at least a proximal portion of the closure element against the carrier portion as said carrier portion is selectably moved from an unexpanded state to an expanded state, urging said closure element from the reduced substantially tubular configuration
20 to the expanded substantially tubular configuration, for deployment thereof.

24. The system of claim 18, wherein

said distal locator portion includes a distal obturator selectably controllable between an unexpanded state and an expanded state for engaging said body lumen.

25

25. The system of claim 24, wherein

in said unexpanded state, said distal locator portion has a transverse cross-sectional dimension less than that of said opening, and

in said expanded state, said distal locator portion has a transverse cross-sectional dimension greater than or substantially equal to that of said opening.
30

26. The system of claim 24, wherein

said carrier portion includes a proximal obturator selectably controllable

between an unexpanded state and an expanded state urging said closure element from the reduced substantially tubular configuration to the expanded substantially tubular configuration, for deployment thereof.

5 27. The system of claim 26, wherein

said distal obturator includes one or more expansion elements configured to expand substantially transversely with respect to a longitudinal axis of the distal locator portion, and

10 said proximal obturator includes one or more expansion elements configured to expand substantially transversely with respect to a longitudinal axis of the carrier portion.

28. The system of claim 27, further including:

15 a locator control system coupled to a proximal end region of said delivery assembly, said locator control system being configured to selectively control said distal locator portion between said expanded state and said unexpanded state; and

a carrier control system coupled to a proximal end region of said delivery assembly, said carrier control system being configured to selectively control said carrier portion between said expanded state and said unexpanded state.

20

29. The system of claim 18, further including:

a pusher member slideably disposed within said cover member, said pusher member including a contact end region configured to distally displace said closure member longitudinally along said delivery assembly.

25

30. The system of claim 29, wherein

said contact end region of said pusher member includes one or more longitudinal extensions extending distally and being configured to expand radially as said distal end region of said pusher member moves distally and engages a distally-increasing transverse cross-sectional dimension of said carrier portion.

30

31. A method for closing an opening formed in a body lumen, comprising:
- extending a distal end region of a distal locator portion of a delivery apparatus through tissue into the opening in the body lumen;
 - engaging said body lumen adjacent to said opening;
 - 5 positioning a carrier portion of the delivery apparatus through said tissue adjacent to said opening, said carrier portion being proximally disposed relative to said locator portion, and said carrier portion, in an unexpanded being configured to support a resilient closure element, naturally in a substantially planar configuration, in a reduced substantially tubular configuration,
 - 10 radially expanding the closure element from the reduced, substantially tubular configuration to an expanded, substantially tubular configuration, via the carrier portion; and
 - distally deploying said closure element from said carrier portion such that said closure element substantially uniformly expands to a cross-section that is greater than
 - 15 a natural cross-section of said closure element, engages said tissue, and returns to said natural, planar configuration and said natural cross-section such that said tissue is drawn substantially closed.

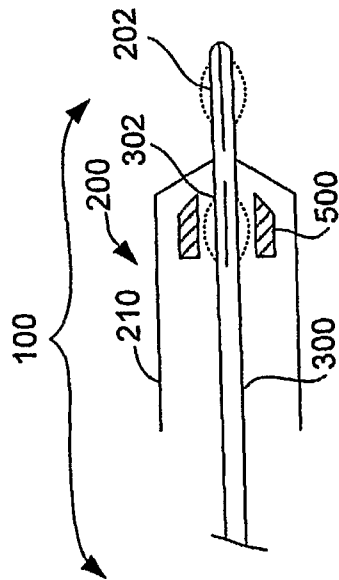

FIG. 1

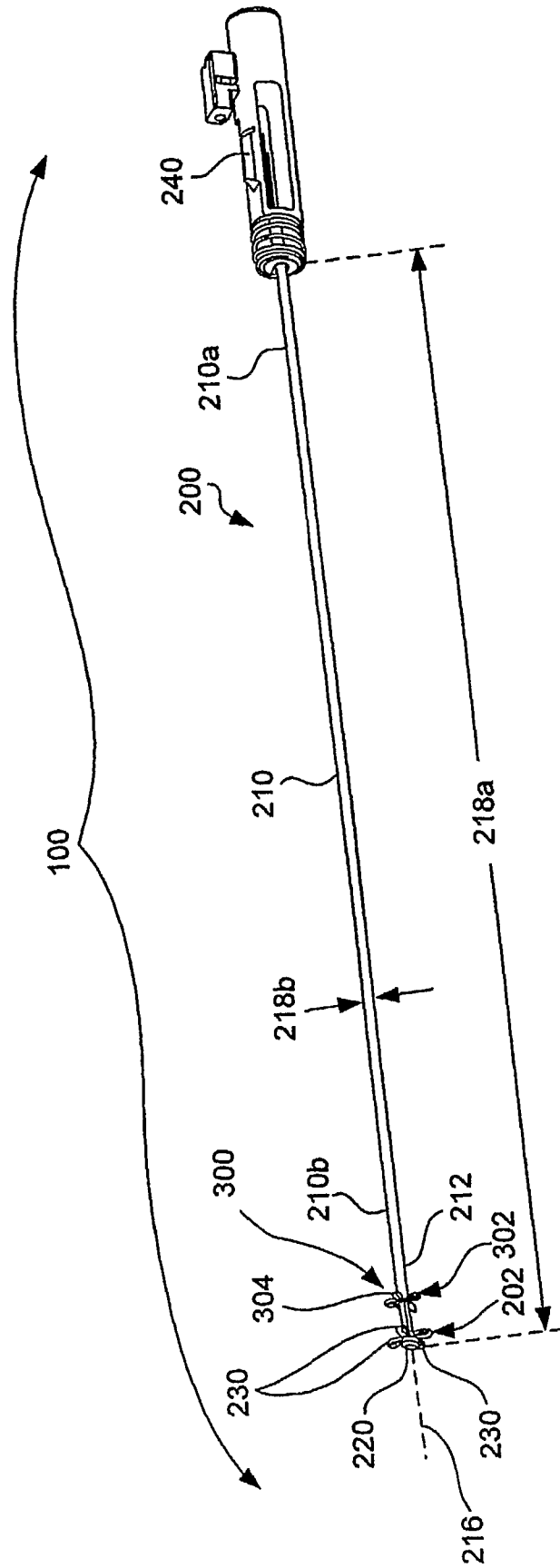

FIG. 2

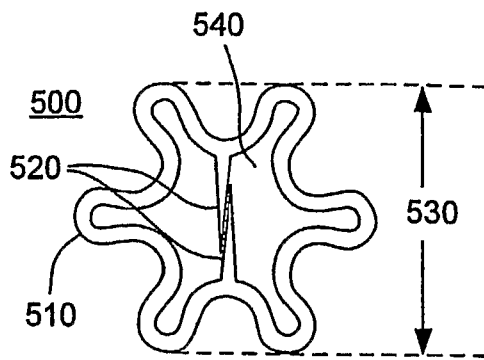

FIG. 3A

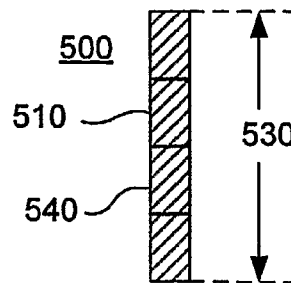

FIG. 3B

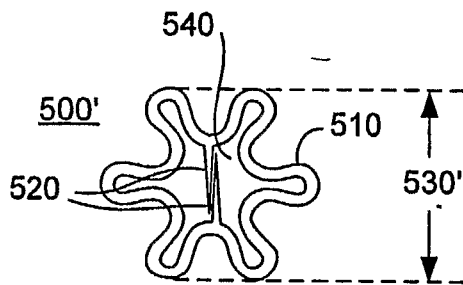

FIG. 3C

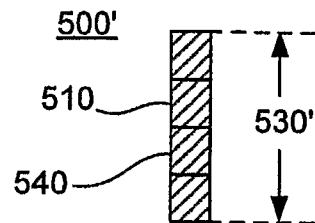

FIG. 3D

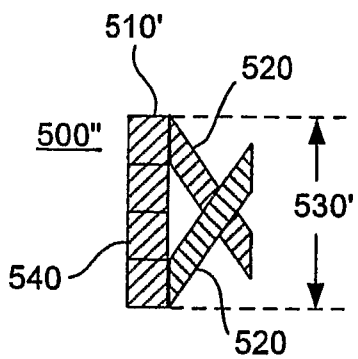

FIG. 3E

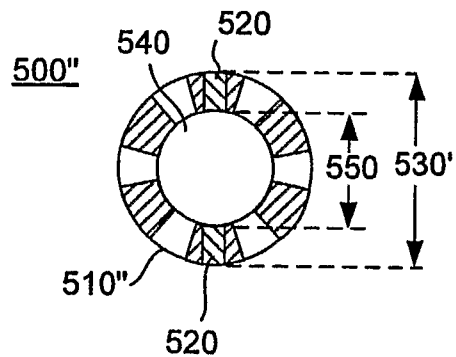

FIG. 3F

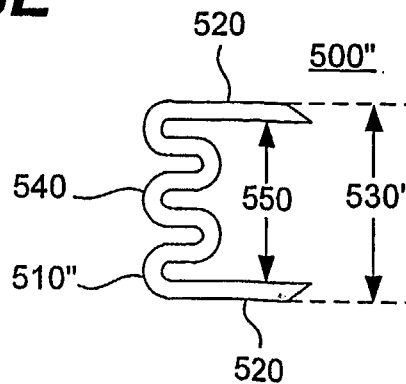

FIG. 3G

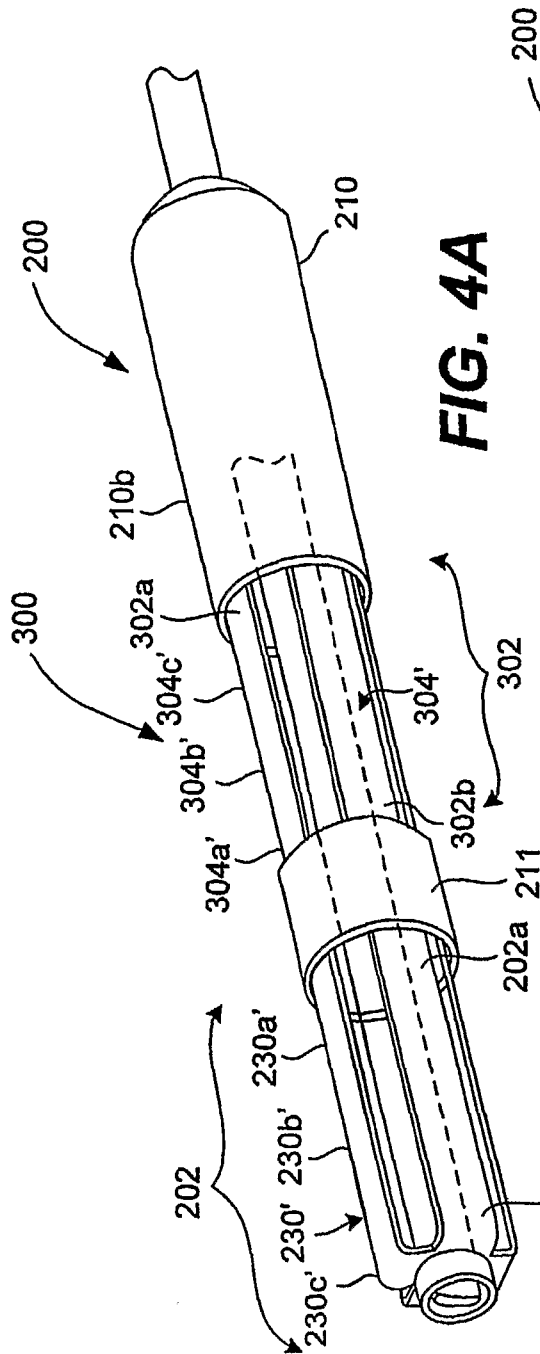

FIG. 4A

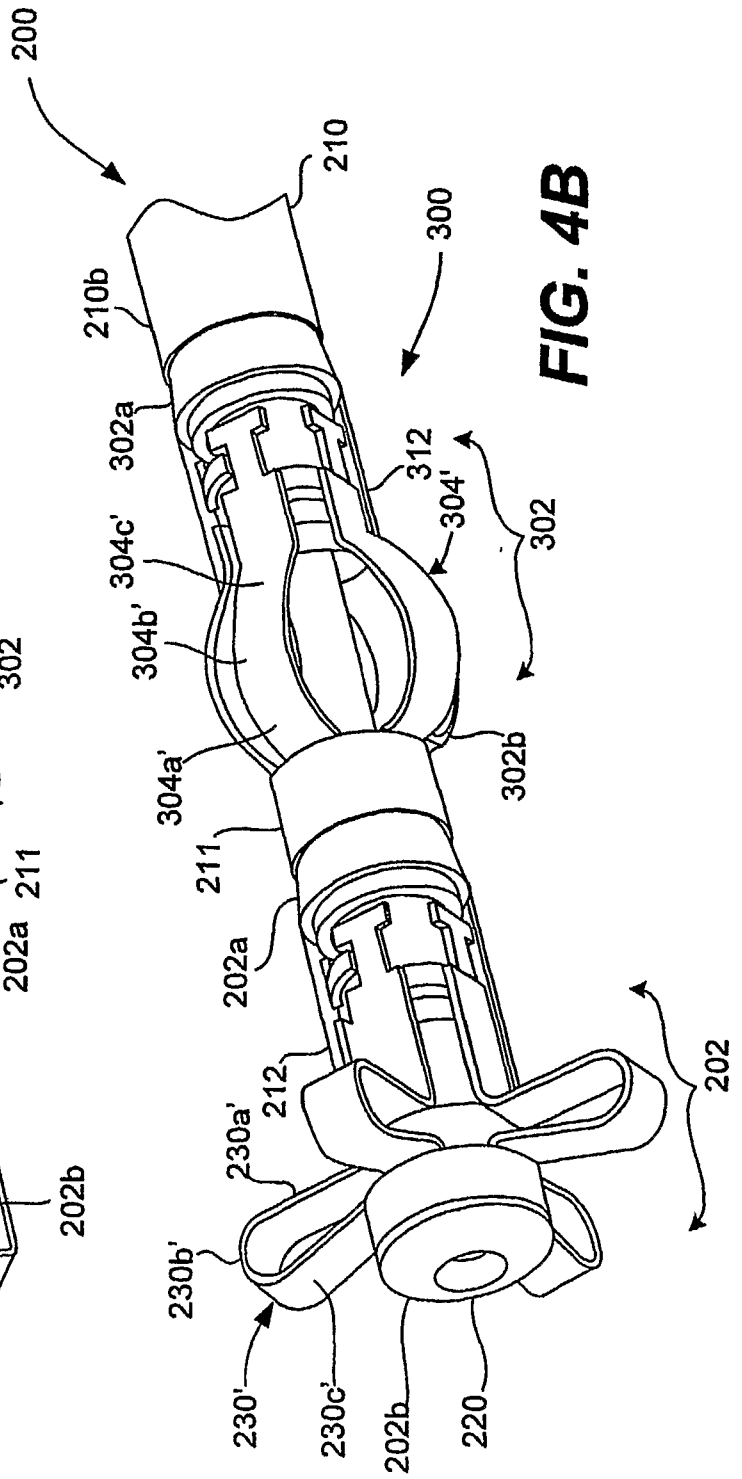

FIG. 4B

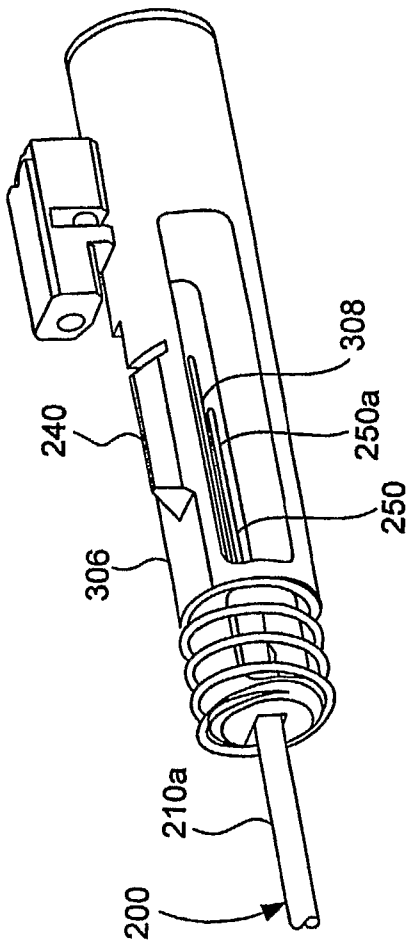

FIG. 4C

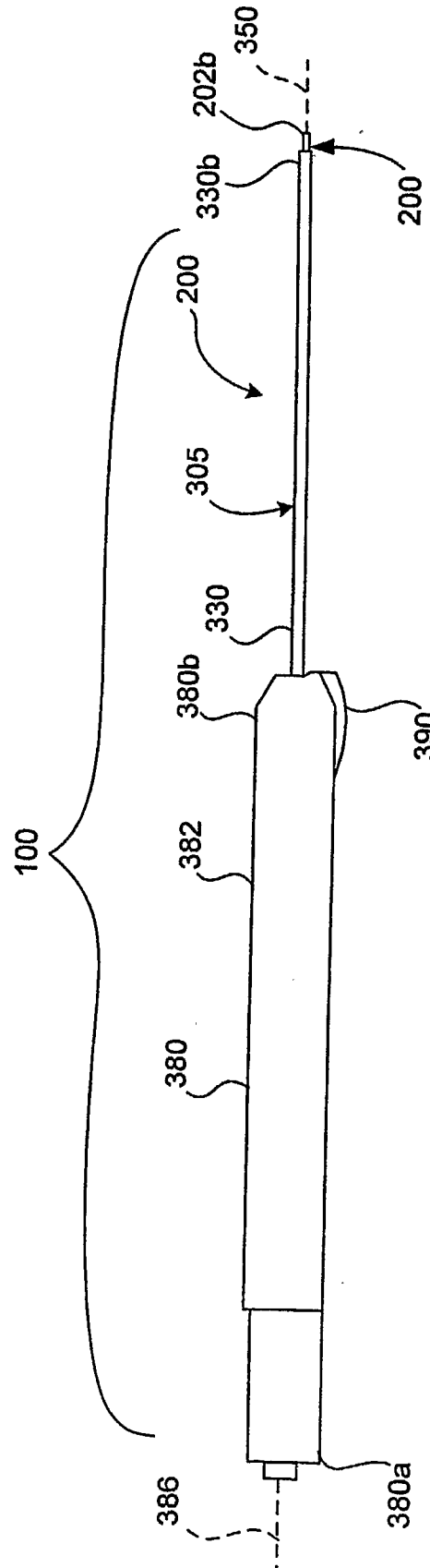

FIG. 6

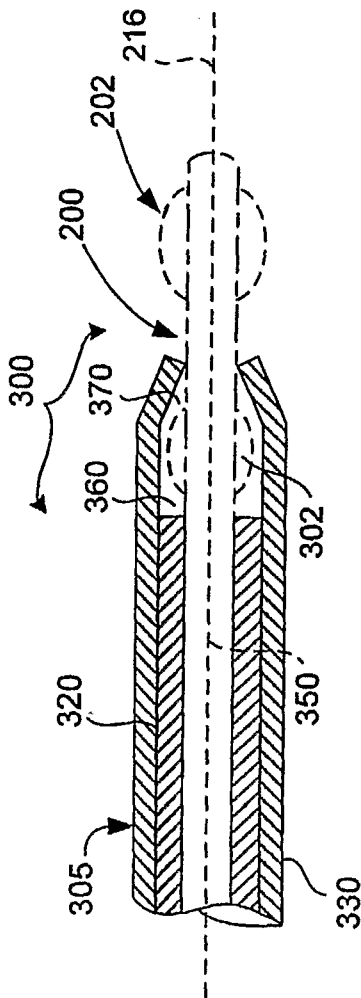

FIG. 5A

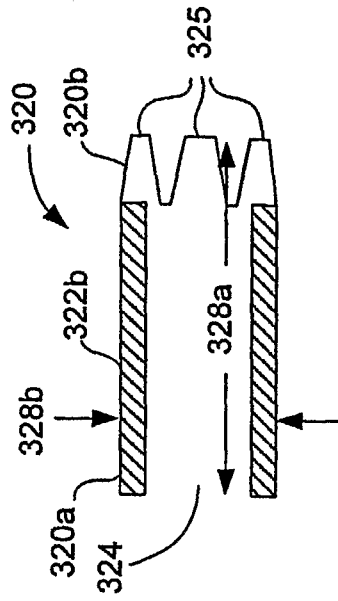

FIG. 5B

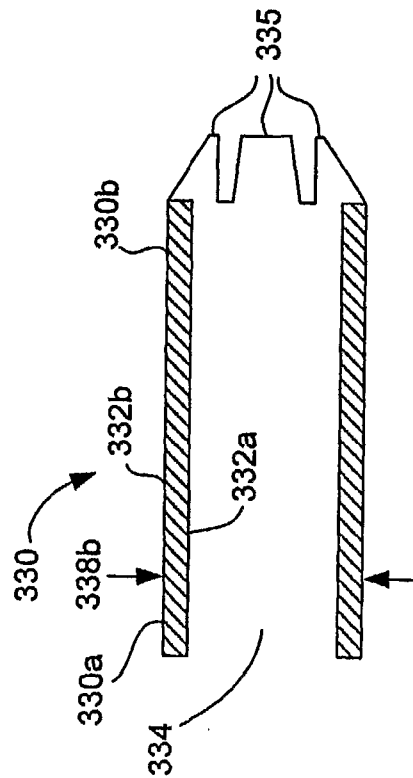

FIG. 5C

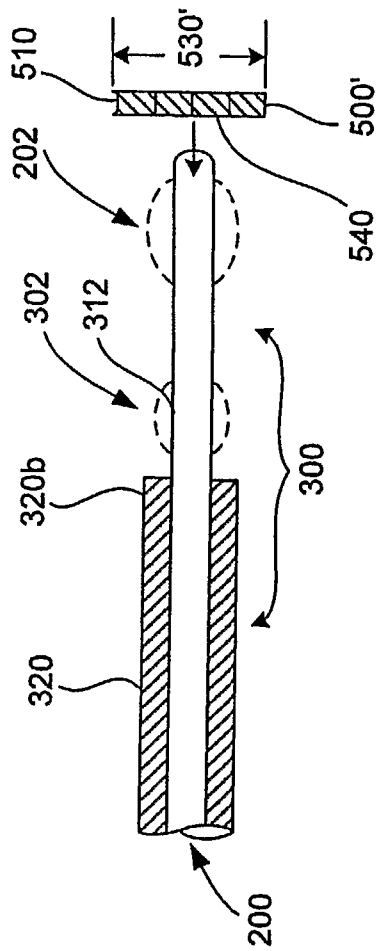

FIG. 7A

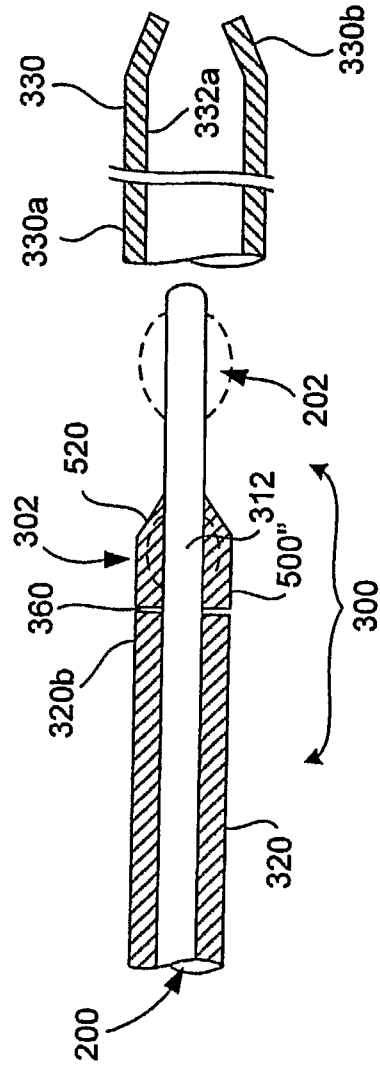

FIG. 7B

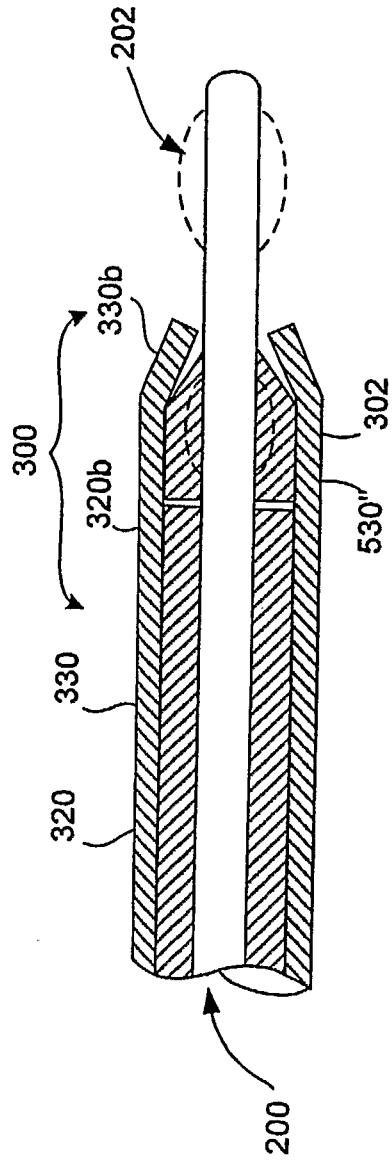

FIG. 7C

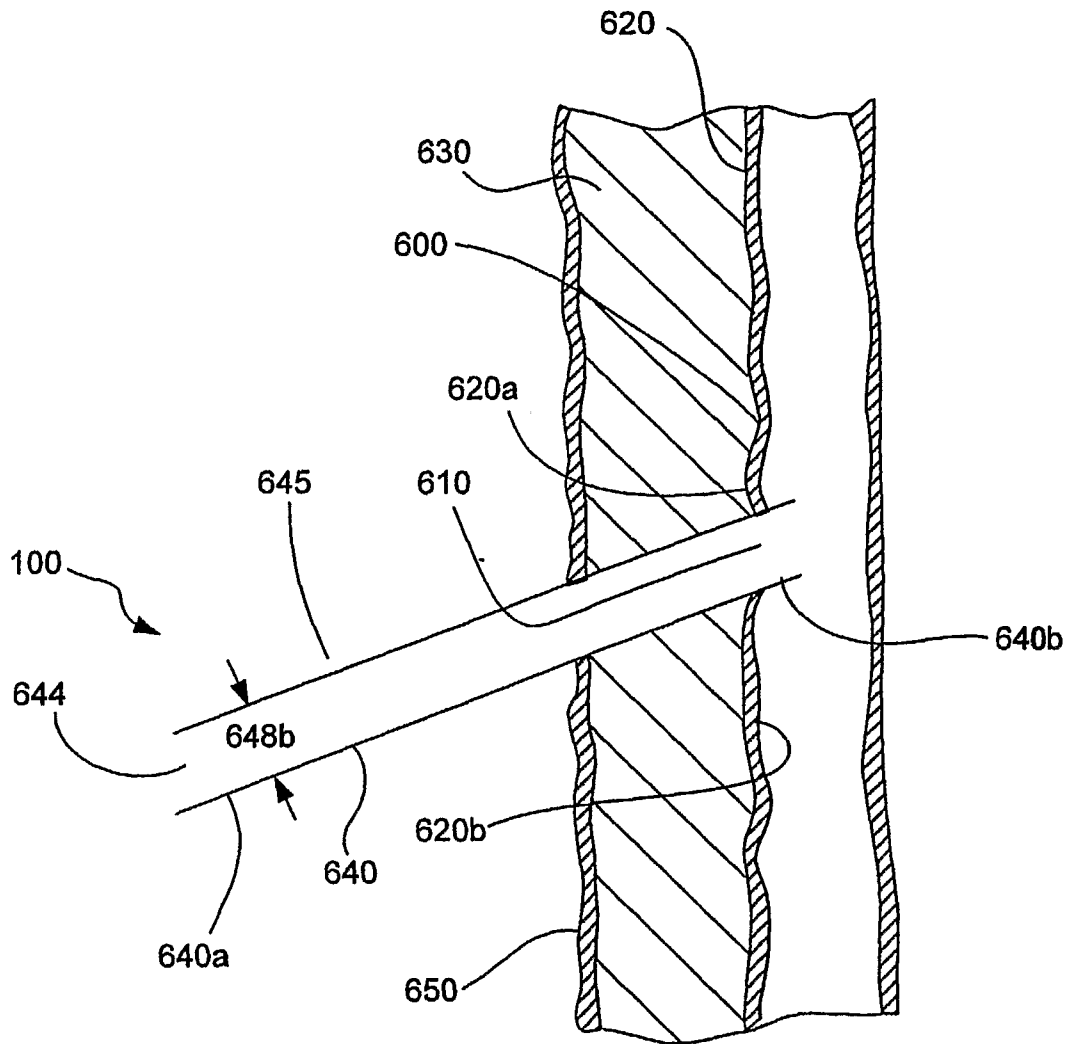

FIG. 8A

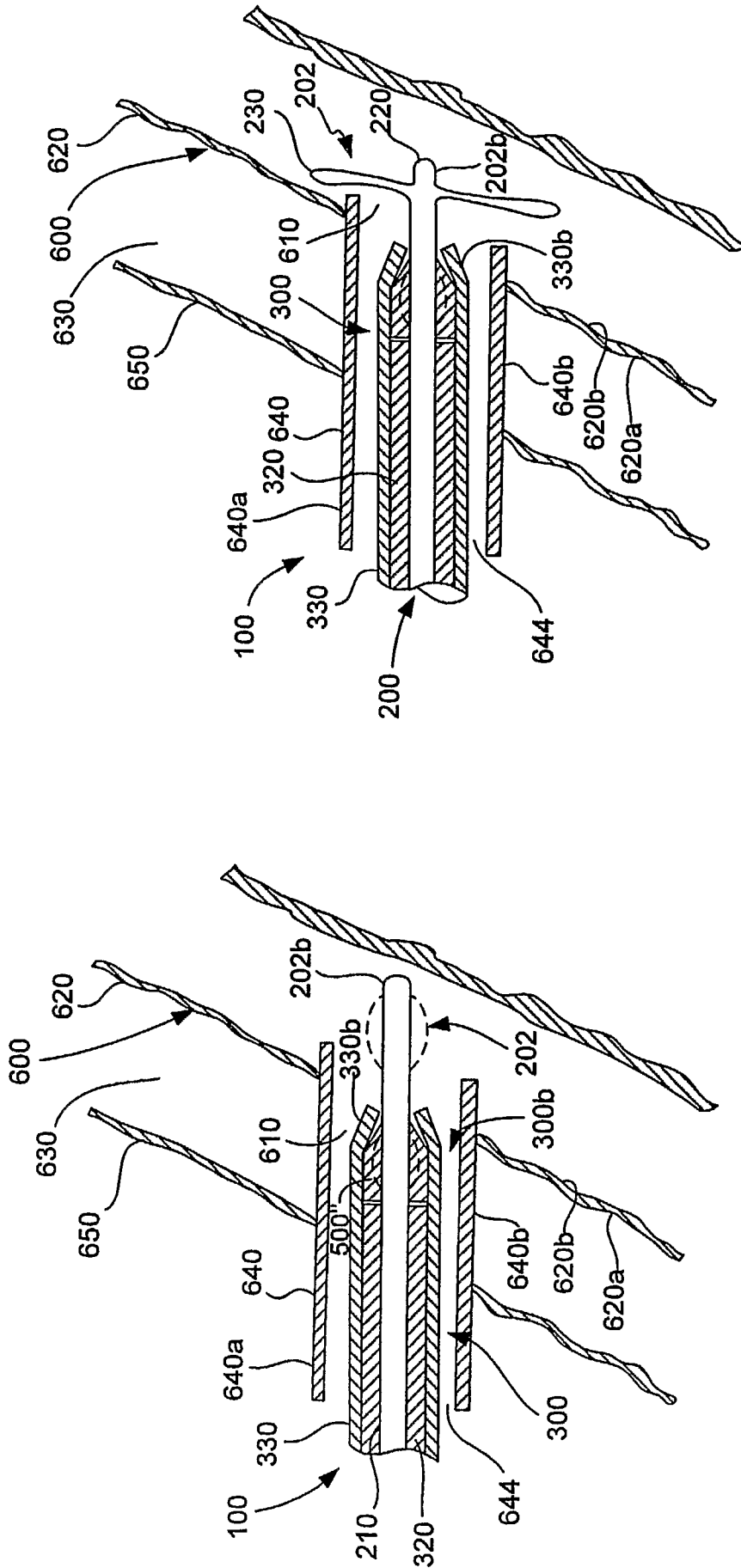

FIG. 8B

FIG. 8C

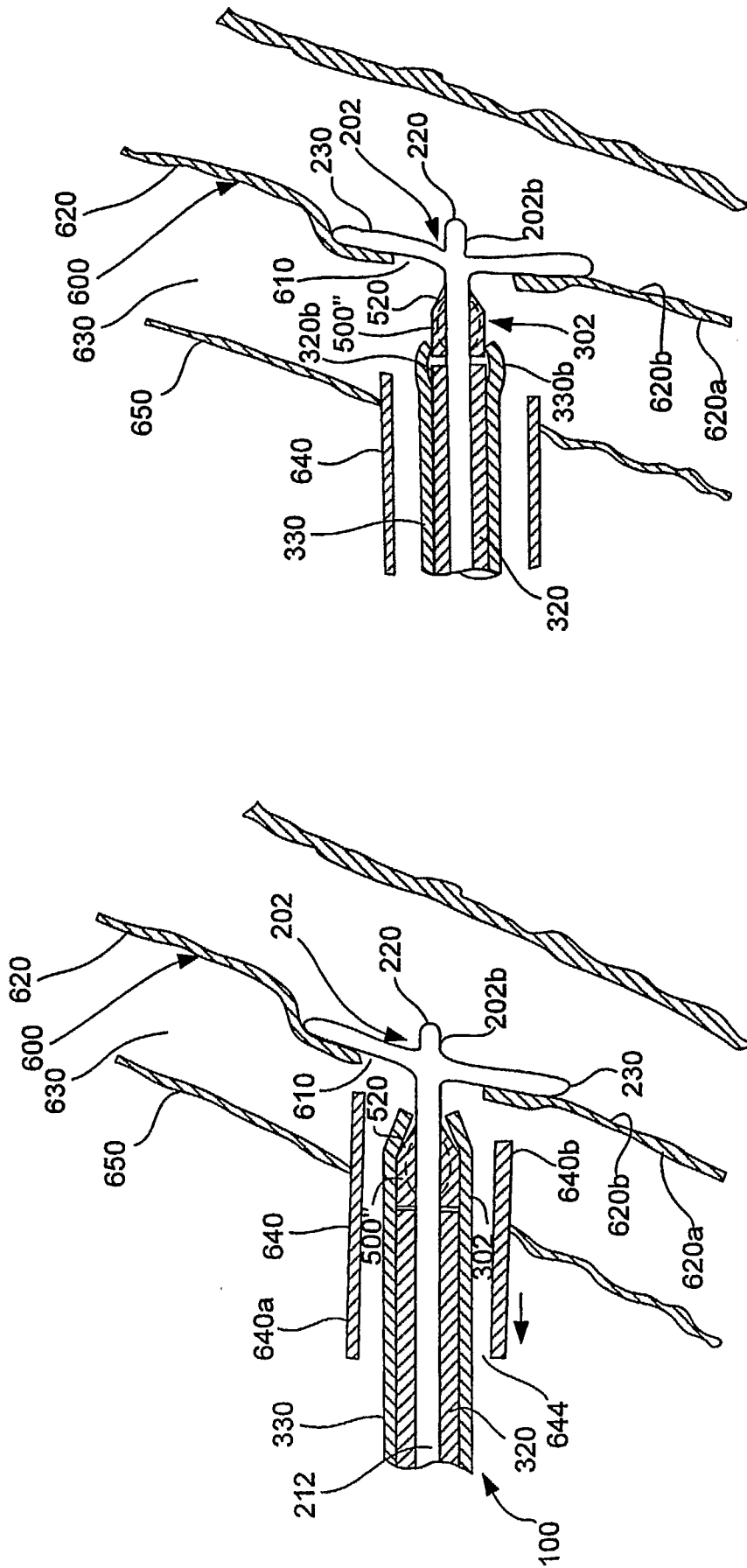

FIG. 8E

FIG. 8D

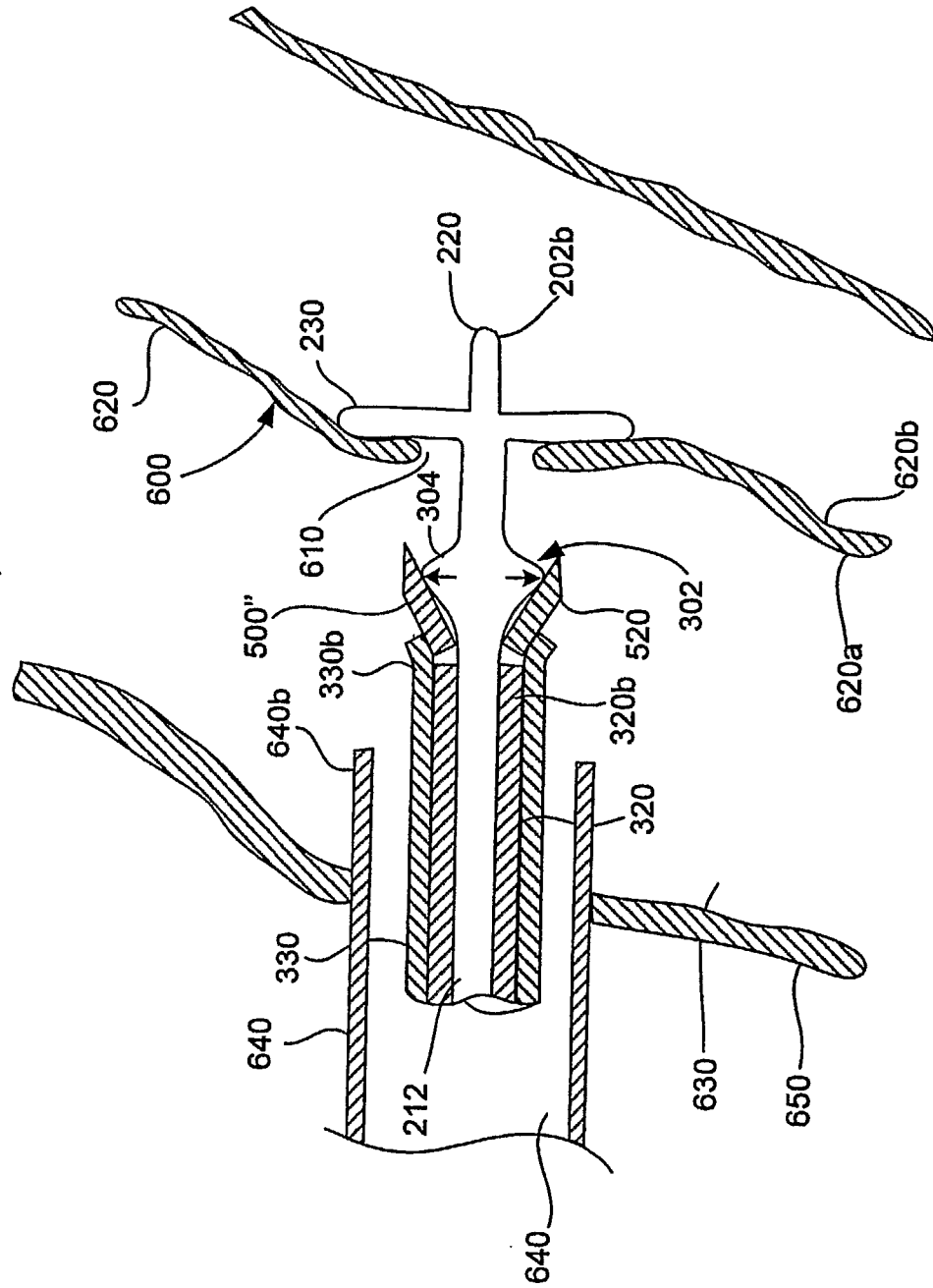

FIG. 8F

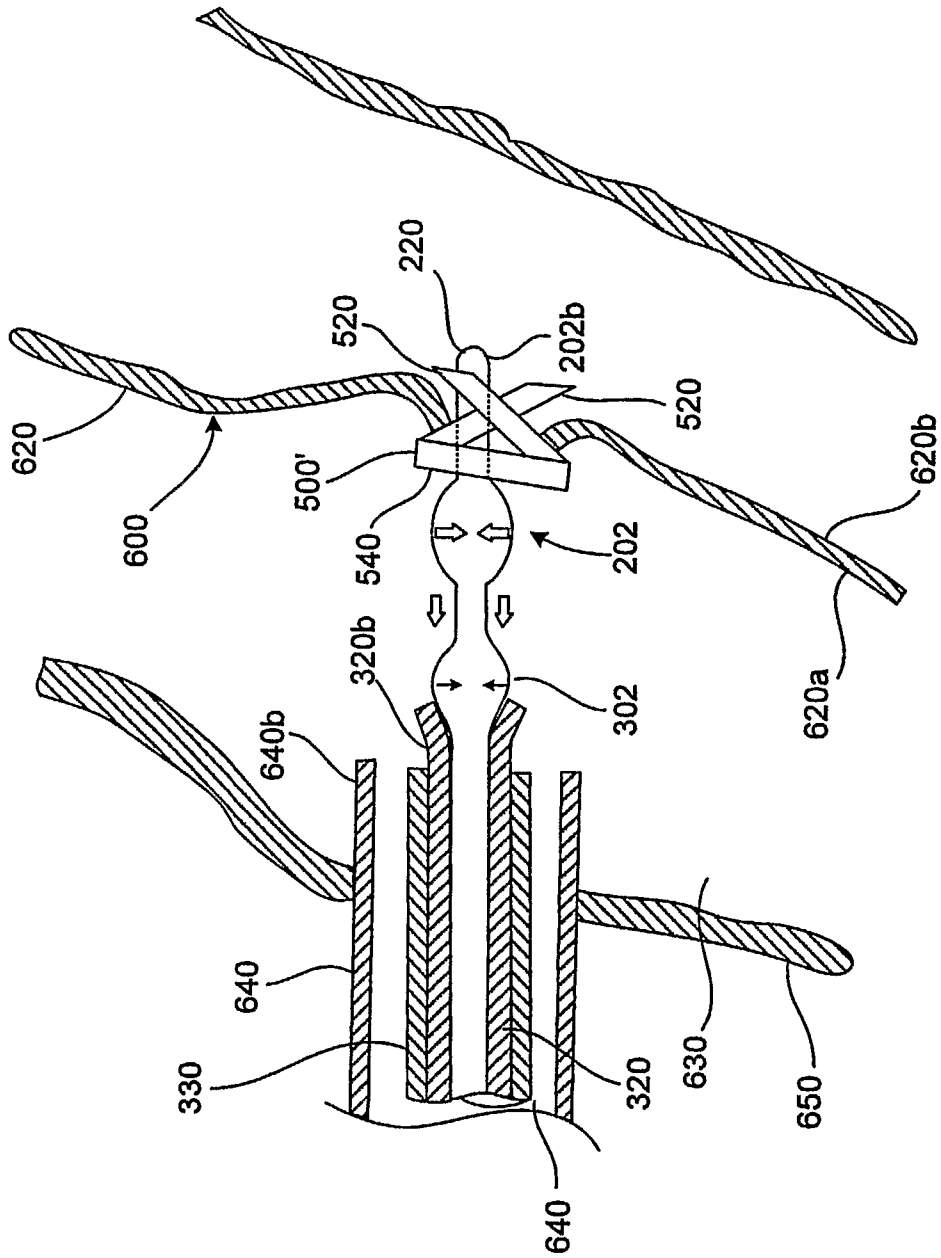

FIG. 8H

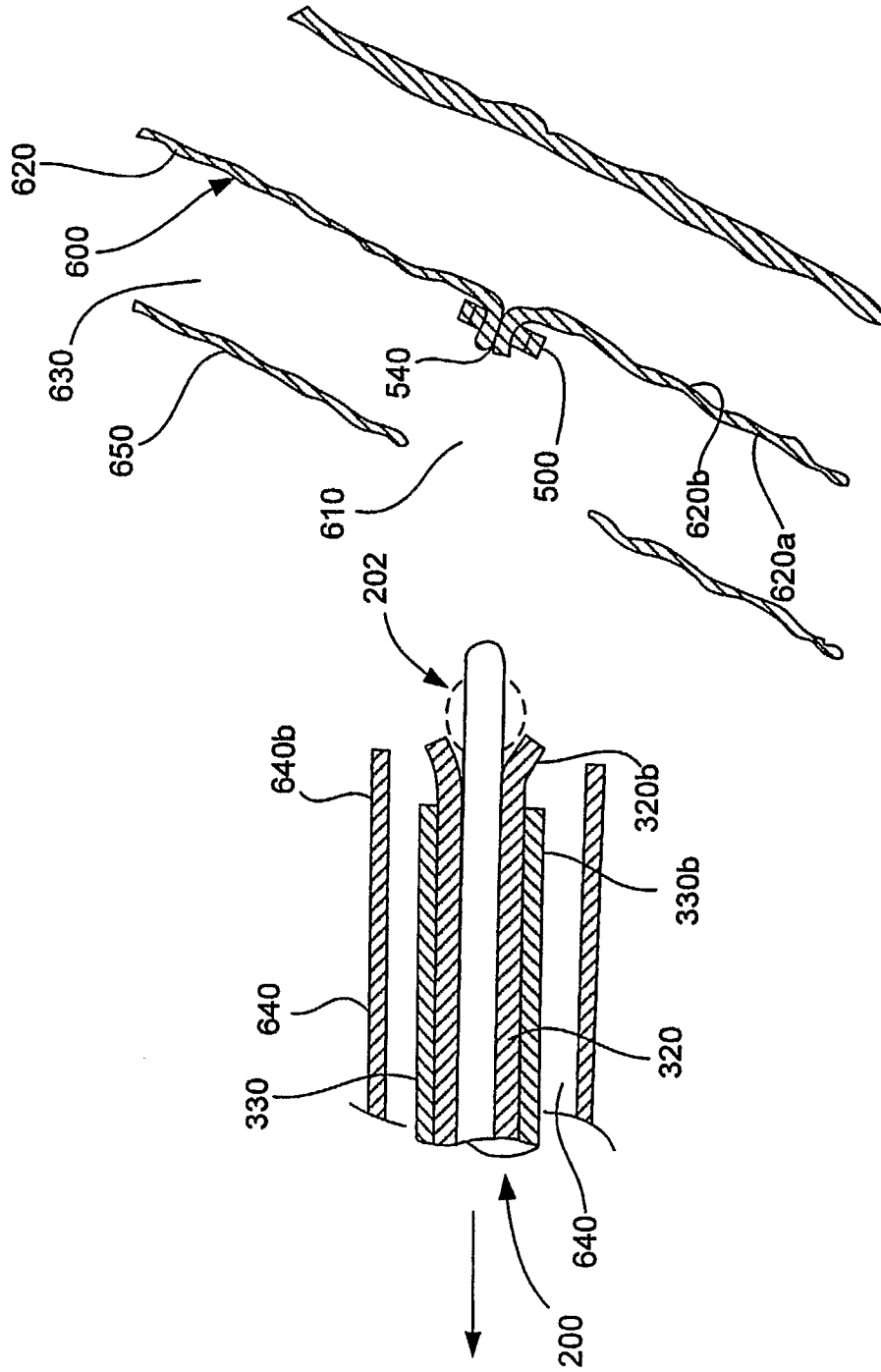

FIG. 81