

June 13, 1961

J. NOVOTNY ET AL
MACHINE FOR ATTACHING SHOE SOLES TO VAMPS

2,987,738

Filed Sept. 10, 1958

3 Sheets-Sheet 1

Fig. 1

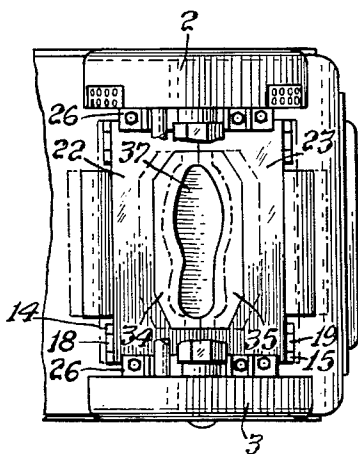
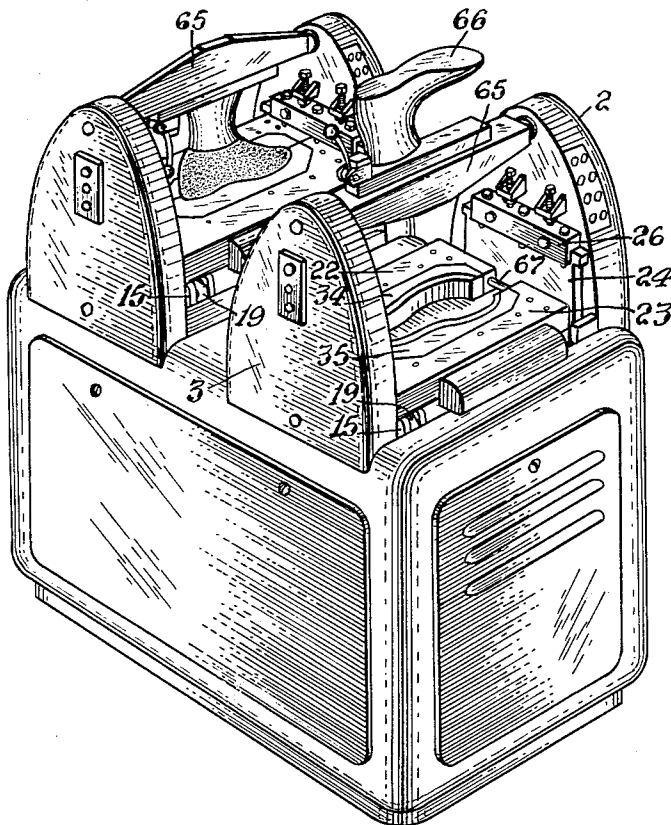

Fig. 4

INVENTORS.
Josef Novotný
BY *Jaroslav Olivík*
Josef Zbořilek
Richard Černý

June 13, 1961

J. NOVOTNY ETAL

2,987,738

MACHINE FOR ATTACHING SHOE SOLES TO VAMPS

Filed Sept. 10, 1958

3 Sheets-Sheet 2

Fig. 2

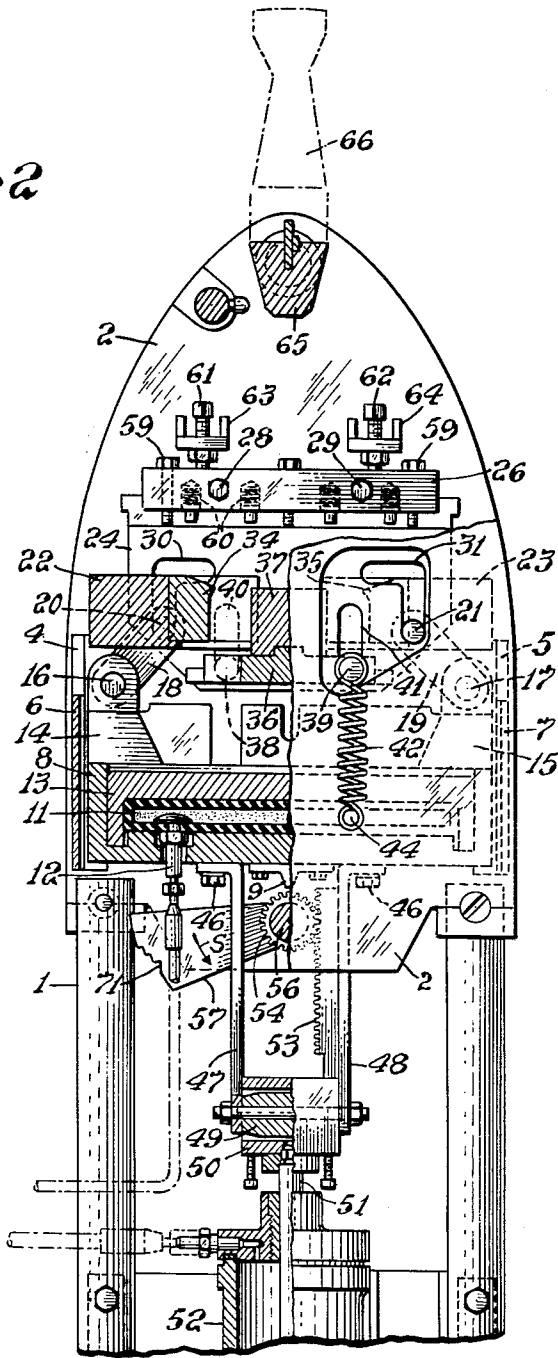

INVENTORS.
Josef Novotný
Jaroslav Olivík
BY Josef Zbořilek
Richard Lund 097

June 13, 1961

J. NOVOTNY ET AL

2,987,738

MACHINE FOR ATTACHING SHOE SOLES TO VAMPS

Filed Sept. 10, 1958

3 Sheets-Sheet 3

Fig. 5

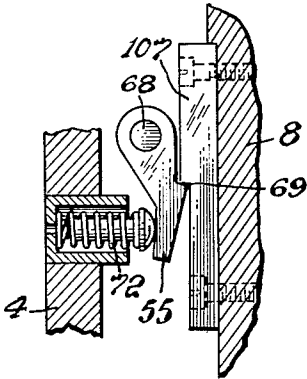

Fig. 6

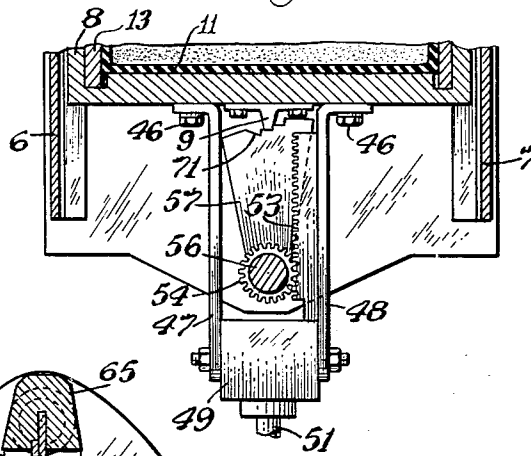
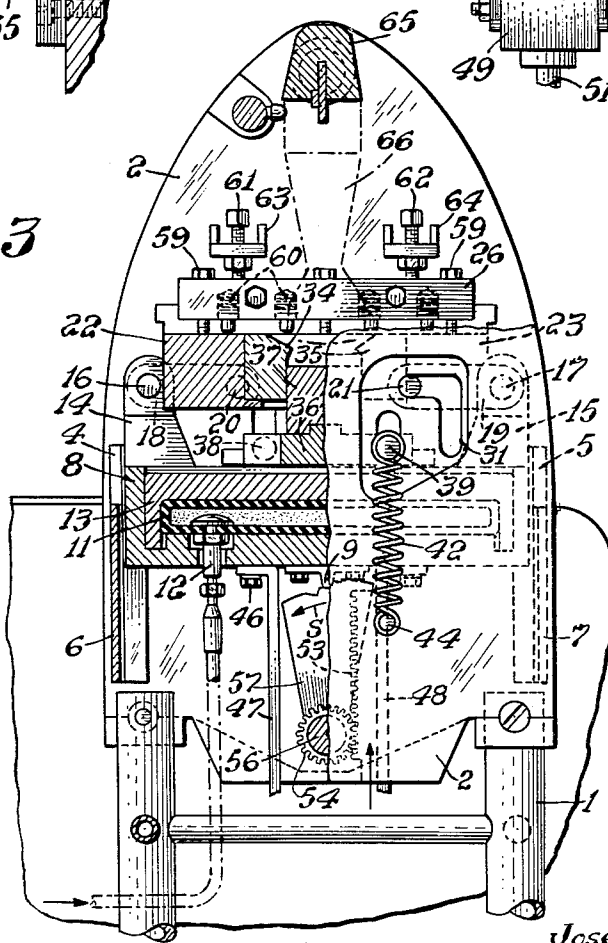

Fig. 3



INVENTORS.
Josef Novotný
BY Jaroslav Olvík
Josef Zbořilek
Reb and Co. 097

1

2,987,738
MACHINE FOR ATTACHING SHOE SOLES
TO VAMPS

Josef Novotný, Jaroslav Olivík, and Josef Zbořilek, all of
 Gottwaldov, Czechoslovakia, assignors to Svit, narodni
 podnik, Gottwaldov, Czechoslovakia
 Filed Sept. 10, 1958, Ser. No. 760,222
 6 Claims. (Cl. 12—33.2)

This invention relates to a machine for automatically
 securing rubber soles to leather or textile vamps by the
 use of pressure applied in a mold.

It is the object of the invention to provide a machine
 which overcomes the shortcomings of hitherto known
 machines of this kind which are manually operated and
 require considerable physical exertion and thus have an
 unsatisfactory rate of output.

The present invention avoids these shortcomings by
 performing all functional movements automatically and
 by permitting control by a workman from a fixed work-
 ing station. His manipulations are limited to pulling
 the vamp over a press-foot, positioning a sole on the
 machine, removing the vamp with sole attached from the
 press foot, and to controlling the operation of the ma-
 chine proper by pressing a single button. A further
 advantage of machines made according to the present in-
 vention consists in their simple and practical arrange-
 ment, suitable for operation by compressed air or other
 pressure fluid and for the electric heating of pressure
 members.

It is a specific feature of the invention that air pres-
 sure is applied in two stages. In the first stage of the
 working cycle, an independent cylinder causes lifting of
 pressing members, closing of a mold formed thereby,
 and locking of the attained position by cams, while in
 the second stage additional pressure is automatically ap-
 plied by means of a member which is then moved
 into the mold cavity.

A machine according to the invention preferably in-
 cludes a plurality of pressing stands arranged in a line
 or in a circle, each comprising an upper bridge carry-
 ing a presser foot and hinged for pivoting movement by
 means of an air cylinder, supporting beams vertically
 adjustable on the side walls of the stand and equipped
 with springs, against which a movable table is auto-
 matically moved by another air cylinder. The table is
 equipped with links which operate the side pressure mem-
 bers of the mold, the pressing jaws proper, and heating
 plates. Cams lock the pressing device in its pressing
 position while additional pressure is applied by the mem-
 ber moving into the mold during the second stage of pres-
 sure operation.

An embodiment of the invention will now be de-
 scribed, by way of example, with reference to the accom-
 panying drawings, in which:

FIG. 1 is a perspective view of a machine of the in-
 vention equipped with a pair of pressing stands,

FIG. 2 is a fragmentary front elevational view of the
 machine of FIG. 1 in its inoperative position, partly in
 section,

FIG. 3 is a view of the device of FIG. 2 in its opera-
 tive position,

FIG. 4 is a fragmentary plan view of a pressing stand
 of the device illustrated in FIG. 1,

FIG. 5 shows a detail of the device of FIG. 1 in
 side-elevational section on an enlarged scale; and

FIG. 6 illustrates a detail of the device shown in FIGS.
 2 and 3.

Referring to the drawings, a frame 1 of a machine
 carries a rear wall 2, a front wall 3, and side walls 4
 and 5. Guides 6 and 7 are arranged in the side walls

2

4 and 5 to guide vertical sliding movement of a table
 8 to the underside of which two prismatic supporting
 members 9 are fastened. Four adjustable pawls 55
 mounted on the side walls 4 and 5 permit the table 8 to
 be locked in its upper position. The table 8 is formed
 with a cavity occupied by an air cushion 11 to which
 compressed air may be admitted through a valve 12.
 The air cushion 11 is confined by a cover member 13
 which slidably fits into the cavity of the table 8. The
 upper face of the table 8 carries brackets 14 and 15
 which support respective pins 16 and 17. Links 18 and
 19 are pivoted to the brackets 14, 15 by the pins 16,
 17 respectively, and to two side pressure members 22
 and 23 by respective pins 20 and 21. The side pres-
 sure members 22 and 23 are movably confined between
 two guides 24 which extend at right angles to the lon-
 gitudinal axes of the pins 20 and 21. The guides 24
 are respectively fastened to two spring loaded vertically
 adjustable supporting beams 26, and the latter are
 fastened to the front and back walls 2 and 3 respectively
 by screws 28 and 29. The supporting beams 26 are
 fitted with adjustable stop screws 59 and are controlled
 by springs 60. Their adjustability in the vertical direc-
 tion is regulated by screws 61 and 62 arranged in holders
 63 and 64. The guides 24 are provided with L-shaped
 guide slots 30 and 31 which are engaged by free ends
 of the pins 20 and 21.

The oppositely facing flanks of the side pressure mem-
 bers 22 and 23 carry presser jaws 34 and 35 which are
 slidable on a locating pin 67 (FIG. 1). A heating plate
 36 supporting a shaped plunger is arranged in the space
 enclosed by the presser jaws 34 and 35.

The guide pins 20 and 21 are effective mainly when
 the jaws 34 and 35 are pulled apart during the opening
 movement of the mold, while, during the closing move-
 ment, their guiding function is taken over by the guides
 24 along which the pressure members 22 and 23 slide.
 Pins 38 and 39 are fastened to the heating plate 36
 and move in vertical grooves or slots 40 and 41 in the
 guides 24. Helical springs, of which only one is shown,
 are respectively attached to the pins 38 and 39 and to
 pins 44 mounted on the walls 2 and 3 to urge the pins
 38, 39 to move downward in the slots 40 and 41.

Brackets 47 and 48 are fastened by screws 46 to the
 underside of the table 8. Their lower ends jointly carry
 a cylindrical spacer 49 on which the forked end of a sup-
 porting hook 50 is suspended. The latter is fixedly con-
 nected with a piston rod 51 of a piston (not shown)
 which works inside cylinder 52, and with a rack 53.

The rack 53 is guided between the brackets 47 and
 48 and engages a pinion 54 which is mounted on a shaft
 56 journaled between walls 2 and 3. Two eccentric
 cams 57 are keyed on the shaft 56 and have notches 71
 cut into their curved surfaces which engage the support
 members 9 and permit pressure to be transmitted thereto
 from the shaft 56 when securing the pressure device
 in its working position.

The table 8 is locked in its upper position by four
 pawls 55 (FIG. 5) suspended on pins 68 which are
 fastened to the side walls 4 and 5. They engage teeth
 69 in rails 107 on the sides of the table 8 under the
 pressure of respective springs 72.

A supporting beam 65, pivoted in the upper parts of
 the walls 2 and 3, carries an exchangeable presser foot
 66. The beam 65 with presser foot 66 can be auto-
 matically pivoted into and out of the operating position
 by a compressed air actuated cylinder (not shown) in
 synchronization with the other movements of the ma-
 chine. The movements of this cylinder are transferred
 to beam 65 by a chain and chain wheel or in any other
 convenient manner.

3

The afordescribed device operates as follows:

The operator first pulls a leather or textile vamp (not shown) over the presser foot 66 when it is in its upwardly projecting position as shown in FIG. 2. Then he places a rubber sole of the monolith, microporous or spongy type upon the plunger 37 between the jaws 34 and 35. By pressing an electric button he starts the machine which then automatically performs all operations. Air is admitted first to the cylinder which causes the presser foot 66 with vamp to be pivoted through 180° into the working position shown in FIG. 3. Then, pressure fluid is admitted to the cylinder 52, the piston rod 51 rises and lifts the supporting hook 50 with brackets 47 and 48 and rack 53 which engages the pinion 54 on shaft 56. This motion causes the table 8 with supporting members, air cushion 11, valve 12 and cover member 13 to move upwards. Simultaneously, the locking cams 57 are turned in the direction of arrow S in FIG. 2 so as to engage the supporting members 9. The lifting motion of the table 8 also causes the links 18 and 19 to rise, and the pins 20 and 21 to move in the vertical portions of the slots 30 and 31 until the side-pressure members 22 and 23 meet the supporting beams 26, whereupon the closing movement of jaws 34 and 35 begins as the pins 20 and 21 enter the horizontal portions of the slots 30 and 31. It continues until the rising upper face of table 8 touches the lower surface of the jaws 34 and 35. By its upward movement, the table 8 also lifts the electrically heated plate 36. At this stage, the sole (not shown) which is placed upon the plunger 37 and is clamped between the jaws, is only partially united with the leather or textile vamp pulled upon the heated foot 66. While the fluid pressure in the cylinder 52 is maintained and while the position of the table 8 is locked by the cams 57 and 58, additional pressure is applied by the cover member 13 which is raised by inflation of the air cushion 11 with compressed air entering through the automatic valve 12. The resulting additional pressure of the air cushion 11 exerts pressure upon the heating plate 36 and the plunger 37 which now acts with greater force upon the rubber sole clamped between the jaws 34 and 35.

While thus pressed together, the shoe is exposed, for three minutes, to electrically produced heat. After this period, a timed electric control device causes the movement of the described machine parts to be reversed. Thus, the air is automatically released from the air cushion 11, causing the additional pressure to be dissipated and the cover member 13 to be lowered. Until an automatic valve (not shown) switches the pressure fluid to act at the upper side of the piston in cylinder 52, the pawls 55 are kept engaged with the teeth 69 of the table 8 by the springs 72 to permit the cams 57 to be partially rotated and become disengaged from the supporting members 9 and 10. Now the piston rod 51 is made to move in a direction opposite to the arrow P (FIG. 2), the table 8 starts moving downwards pushing aside the pawls 55 against the pressure of the springs 72, the jaws 34 and 35 move apart, the plunger 37 and heating plate 36 drop, the cams 57 reach the position indicated in FIG. 2 and the presser foot 66 moves upwards to the position indicated in FIG. 2, carrying the vamp and the rubber sole (not shown) which is now vulcanized to the vamp.

By lifting the separate heel parts out of the main body of the foot 66, the operator has no difficulty in pulling the finished shoe off the foot. He pulls a new vamp over it and inserts a new rubber sole in the machine whereupon the cycle of operations is repeated.

An advantage of the automatic function of the described machine is that it requires only a minimum of attendance which is limited to pulling the vamp over the presser foot 66 and removing it, and placing a rubber sole on the plunger 37 between the jaws 34 and 35. By the construction of a machine designed in accordance with the

4

present invention, the hitherto needed physical effort of the operator has been eliminated and the productivity is increased.

The invention is not limited to the illustrated arrangement of two pressing stands. It is advantageous to arrange a greater number of them in a line or in a circle or otherwise, and this can be done without departing from the scope or spirit of the invention as hereinafter defined by the appended claims.

What is claimed is:

1. In a device for securing soles to vamps of shoes under the action of pressure, in combination, a support; a vamp carrier member movable on said support between an operative first position and an inoperative second position; two side pressure members movable on said support relative to each other between a closely spaced first position and a remotely spaced second position; a motion transmitting member movable on said support toward and away from said operative position of said vamp carrier member between a first position close to said vamp carrier member, and a second position remote therefrom, said members, when in said respective first positions thereof, jointly defining a mold cavity; a bottom pressure member on said motion transmitting member; and means for moving said bottom pressure member relative to said motion transmitting member into said cavity when said motion transmitting member is in said first position thereof.

2. In a device for securing soles to vamps of shoes under the action of pressure, in combination, a support; a vamp carrier member rotatable on said support between an operative first position and an inoperative second position; two side pressure members movable on said support relative to each other between a closely spaced first position and a remotely spaced second position; a motion transmitting member movable on said support toward and away from said operative position of said vamp carrier member between a first position close to said vamp carrier member, and a second position remote therefrom, said members, when in said respective first positions thereof, jointly defining a mold cavity; a bottom pressure member on said motion transmitting member; actuating means for jointly moving said side pressure members and said motion transmitting member between said respective first and second positions thereof; and means for moving said bottom pressure member relative to said motion transmitting member into said cavity when said motion transmitting member is in said first position thereof.

3. In a device for securing soles to vamps of shoes under the action of pressure, in combination, a support; a vamp carrier member movable on said support between an operative first position and an inoperative second position; two side pressure members movable on said support relative to each other between a closely spaced first position and a remotely spaced second position; a motion transmitting member movable on said support toward and away from said operative position of said vamp carrier member between a first position close to said vamp carrier member, and a second position remote therefrom, said members, when in said respective first positions thereof, jointly defining a mold cavity; cam means movable on said support for releasably securing said motion transmitting member in said first position thereof; a bottom pressure member on said motion transmitting member; and means for moving said bottom pressure member relative to said motion transmitting member into said cavity when said motion transmitting member is in said first position thereof.

4. In a device for securing soles to vamps of shoes under the action of pressure, in combination, a support; a vamp carrier member rotatable on said support between an operative first position and an inoperative second position; two side pressure members movable on said support relative to each other between a closely spaced first posi-

5

tion and a remotely spaced second position; a motion transmitting member movable on said support toward and away from said operative position of said vamp carrier member between a first position close to said vamp carrier member, and a second position remote therefrom, said members, when in said respective first positions thereof, jointly defining a mold cavity; cam means movable on said support for releasably securing said motion transmitting member in said first position thereof; a bottom pressure member on said motion transmitting member; actuating means for jointly moving said side pressure members and said motion transmitting member between said respective first and second positions thereof, and for simultaneously moving said cam means into and out of a position in which said cam means secure said first position of said motion transmitting member; and means for moving said bottom pressure member relative to said motion transmitting member into said cavity when said motion transmitting member is in said first position thereof.

5. In a device for securing soles to vamps of shoes under the action of pressure, in combination, a support; a vamp carrier member movable on said support between an operative first position and an inoperative second position; two side pressure members movable on said support relative to each other between a closely spaced first position and a remotely spaced second position; a motion transmitting member movable on said support toward and away from said operative position of said vamp carrier member between a first position close to said vamp carrier member, and a second position remote therefrom, said members, when in said respective first positions thereof, jointly defining a mold cavity; cam means movable on said support for releasably securing said motion transmitting member in said first position

6

thereof; pawl means mounted on said support for additionally securing said motion transmitting member in said first position thereof to permit release of said cam means; a bottom pressure member on said motion transmitting member; and means for moving said bottom pressure member relative to said motion transmitting member into said cavity when said motion transmitting member is in said first position thereof.

6. In a device for securing soles to vamps of shoes under the action of pressure, in combination, a support; a vamp carrier member movable on said support between an operative first position and an inoperative second position; two side pressure members movable on said support relative to each other between a closely spaced first position and a remotely spaced second position; a motion transmitting member movable on said support toward and away from said operative position of said vamp carrier member between a first position close to said vamp carrier member, and a second position remote therefrom, said members, when in said respective first positions thereof, jointly defining a mold cavity; connecting linkage means secured to said motion transmitting member and to said side pressure members for transmitting movement of said motion transmitting member to said side pressure members; a bottom pressure member on said motion transmitting member; and means for moving said bottom pressure member relative to said motion transmitting member into said cavity when said motion transmitting member is in said first position thereof.

References Cited in the file of this patent

UNITED STATES PATENTS

1,629,920	MacDonald	May 24, 1927
2,386,902	Knowlton	Oct. 16, 1945
2,579,896	Ashley	Dec. 25, 1951