

Jan. 15, 1963

E. DAVIDSON

3,073,473

DECANTER ASSEMBLY

Filed May 17, 1961

FIG. 1.

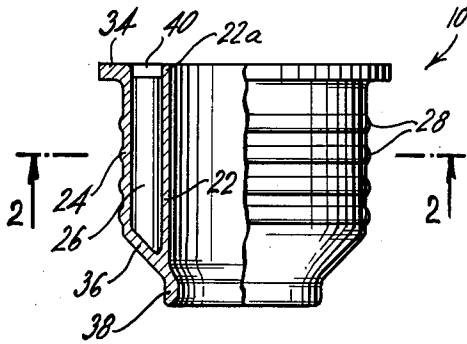

FIG. 2.

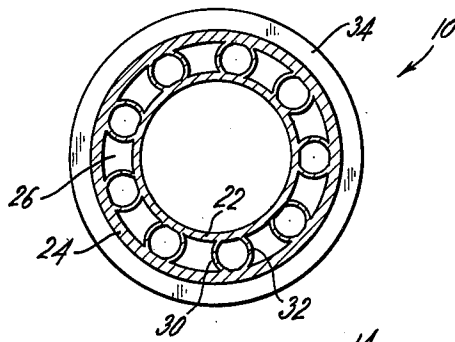

FIG. 3.

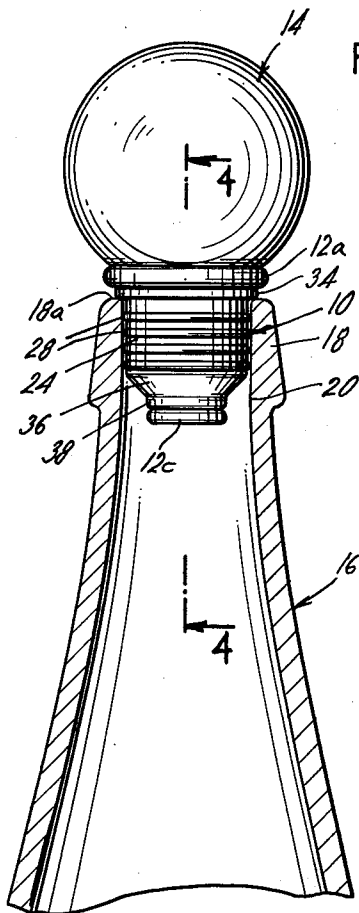
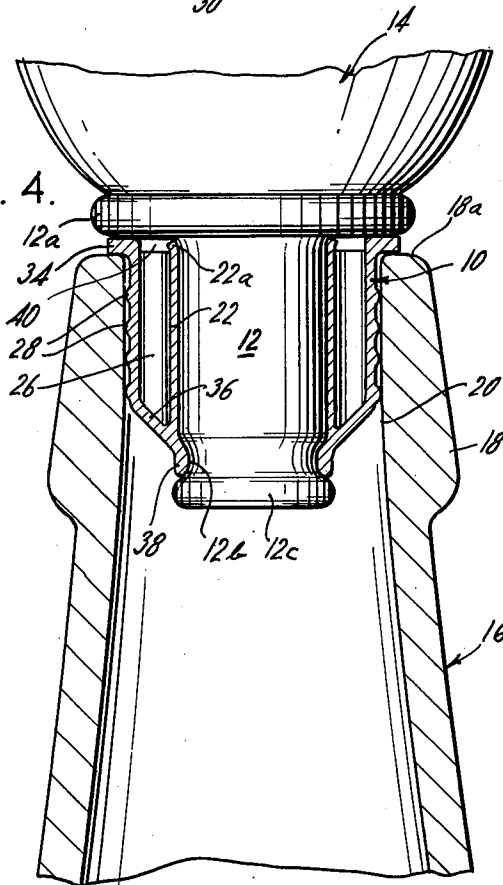

FIG. 4.



INVENTOR.  
EMIL DAVIDSON  
BY *Ameter & Levy*  
ATTORNEYS.

1

3,073,473

**DECANTER ASSEMBLY**

Emil Davidson, Scarsdale, N.Y., assignor to Guild Molders, Inc., Elmsford, N.Y., a corporation of New York  
 Filed May 17, 1961, Ser. No. 110,724  
 9 Claims. (Cl. 215—48)

The present invention relates generally to a closure for a decanter, and in particular to an improved stopper for such closure.

The usual decanter which has found widespread use in the sale of alcoholic beverages including wines and whiskeys comprises a decanter body or bottle having a neck which is bounded by a substantially cylindrical neck wall defining a dispensing opening. The decanter bottle is closed by a closure which includes a depending stopper-mounting member carrying thereon a stopper. Such stopper is usually fabricated of cork which, although relatively frangible, provides a fluid-tight seal for the dispensing opening of the decanter bottle. The use of a cork stopper provides many problems, both at the level of the manufacturer and the consumer. Cork being a natural product is often in limited supply, and is relatively expensive, and exhibits a rather high order of surface porosity thereby requiring a relatively large area seal to provide a fluid-tight closure. Further, due to its fragility, it is not uncommon for the stopper to break and/or to loosen from the closure proper. Still further, experience indicates that a cork stopper often imparts a taste to the liquid in the decanter. Accordingly, it is not uncommon for gasketing to be employed in conjunction with such cork stoppers to impart the necessary structural strength thereto and to somewhat isolate the same from the contents of the decanter. Of course, this represents a substantial increase in the cost of the closure, due both to the additional cost of materials and to the expense of the labor necessary to complete the assembly.

Broadly, it is an object of the present invention to provide an improved closure for a decanter which obviates one or more of the aforesaid difficulties.

Plastics which may be readily molded, such as polyethylene, have been found to exhibit the requisite properties to replace the conventional cork stopper for closures. Polyethylene is impervious to attack by liquor, imparts a minimal taste thereto (at least in an amount less than cork), has a low order of surface porosity, and is relatively inexpensive. With available molding techniques, this material is adaptable to provide a relatively low cost one-piece stopper suitable to replace the cork stopper. Various types of polyethylene stoppers have been suggested, but none have gained widespread commercial acceptance for a variety of reasons, including without limitation, the difficulty of providing a fluid-tight closure in the neck of the decanter bottle, the difficulty of attaining a leakproof seal between the stopper and the stopper-mounting member of the closure and the relative complexity in assembling the stopper on the stopper-mounting member of the closure.

It is a further object of the present invention to provide an improved stopper for a decanter closure which may be fabricated by injection molding techniques, employing polyethylene and other similar moldable plastics, and is capable of flexing radially to accommodate itself to irregularities in the dispensing opening of the decanter

2

bottle and the diameter thereof, yet provides a fluid-tight seal to the stopper-mounting member of the closure.

In accordance with an illustrative embodiment demonstrating objects and features of the present invention there is provided an improved stopper fabricated of a resilient plastic which is adapted to be used in a decanter of the type including a neck having a substantially cylindrical neck opening and a closure for the decanter which includes a depending stopper-mounting member. The stopper is mounted on a stopper-mounting member and is adapted to provide a fluid-tight seal for the dispensing opening, despite variations in diameter from dispensing opening to dispensing opening and inherent irregularities which exist in the neck walls incident to the manufacture of such glass decanter bottles. The stopper includes cylindrical inner and outer walls which are disposed in coaxial relation and cooperate to provide an annular space therebetween. The inner wall is of a diameter to provide a tight fit over the stopper mounting member, while the outer wall is of a diameter to provide a tight fit within the neck wall of the decanter bottle. A plurality of circumferentially spaced ribs bridge the annular space and interconnect the inner and outer walls, with the ribs being arranged relative to each other to permit the stopper to readily accommodate to irregularities in the neck wall. Advantageously, the desired radial flexibility may be imparted to the stopper by arranging the ribs in pairs which are curved and in spaced relation to each other, with each pair of ribs being positioned relative to each other and of a curvature to lie on the common circle having a diameter less than the spacing between the inner and outer walls.

As a further feature of the invention, the mounting of the stopper on the stopper-mounting member is such that at least the inner wall of the stopper is placed into longitudinal compression when assembled on the stopper-mounting member to urge the inner wall into sealing contact with the stopper-mounting member and thereby provide an exceptionally good fluid-tight seal between the components of the closure, yet afford the requisite flexibility to the stopper.

The above brief description, as well as further objects, features and advantages of the present invention will be more fully appreciated by reference to the following detailed description of a presently preferred, but nonetheless illustrative embodiment according to the present invention, when taken in conjunction with the accompanying drawing, wherein:

FIG. 1 is an elevational view, with parts broken away and sectioned, of an improved decanter stopper embodying features of the present invention;

FIG. 2 is a sectional view taken substantially along the line 2—2 of FIG. 1 and looking in the direction of the arrows;

FIG. 3 is an elevational view showing the improved decanter stopper illustrated in FIGS. 1 and 2 mounted on a closure or top for a decanter, the latter being shown in section; and,

FIG. 4 is a sectional view, on an enlarged scale taken substantially along the line 4—4 of FIG. 3, with the decanter closure and its depending stopper-mounting member not sectioned.

Referring now specifically to the drawing, there is

3

shown an improved decanter stopper, generally designated by the reference numeral 10, which is adapted to be mounted on the depending stopper-mounting member 12 of a closure or top 14 such as to provide a fluid-tight seal for a decanter bottle or body 16 including a neck 18 having a substantially cylindrical internal neck wall 20 bounding and defining a dispensing opening.

As seen best in FIGS. 1 and 2, the stopper 10 is of a unitary construction and is preferably fabricated of a resilient plastic, such as polyethylene, and which may be injection molded. The stopper includes a cylindrical inner wall 22 and a cylindrical outer wall 24 which is spaced therefrom. The inner and outer walls 22, 24 are disposed in coaxial relation and cooperate to define an annular space 26 therebetween. The inner wall 22 is of a diameter to provide a tight fit over the stopper-mounting member 12 (see FIG. 4), while the outer wall 24 is of a diameter to provide a tight fit with the neck wall or dispensing opening 20 of the decanter bottle or body 16 (see FIG. 3). Preferably the outer wall 24 is provided with a plurality of circumferentially extending and longitudinally spaced sealing glands 28, as seen best in FIGS. 1, 3 and 4.

The inner and outer walls 22 and 24 are interconnected by a plurality of circumferentially spaced ribs which bridge the annular space 26 and interconnect the inner and outer walls, one such pair being seen in FIG. 2 and designated by the reference numeral 30, 32. The successive pairs of ribs 30, 32 are curved and in facing relation, with each pair of ribs being positioned relative to each other and of a curvature to lie on a common circle having a diameter greater than the spacing between the inner and outer walls 22, 24. The ribs are of substantially the same thickness as the walls 22, 24 and merge into such walls. With this rib array, which may be attained by injection molding, it is found that the outer wall 24 of the stopper 10 may readily accommodate by radial compression to varying contours and diameters presented by the neck or dispensing opening 20 as encountered in commercial practice.

At its upper end, the outer wall 24 is provided with a radially extending sealing flange 34 which is adapted to overlie and bear against the upper edge 18a of the neck wall 18 contiguous to the dispensing opening 20 (see FIGS. 3 and 4). The sealing flange prevents glass to glass contact between the closure 14 and the bottle 16 and serves as a stop to prevent the stopper 10 from entering the bottle 16. At its lower end, the outer wall 24 is joined to the inner wall 22 by a cross wall 36 which is of frusto-conical shape, with its larger diameter end integral with the lower end of the outer wall 24 and its smaller diameter lower end integral with the inner wall 22.

The junction of the inner wall 22 and the cross wall 36 merge into an annular sealing ring 38 at the lower end of the stopper 10, which sealing ring 38 is inwardly directed and has an inner diameter less than the inner diameter of the inner wall 22. The radially-extending sealing flange 34 and the sealing ring 38 are spaced in relation to each other such that at least the inner wall 22 of the stopper 10 is placed into longitudinal compression when assembled on the stopper-mounting member 12 such as to urge the inner wall 22 into intimate fluid-sealing contact with the stopper-mounting member 12. To this end, and as seen best in FIG. 4, the stopper-mounting member 12 terminates at its upper end in shoulder or seating member 12a having an enlarged diameter while the lower end thereof is provided with an annular seat 12b which merges at its upper end with the stopper-mounting member proper and at its lower end with an enlarged bead or retaining lip 12c. The sealing flange 34 and the sealing ring 38 of the stopper 10 are arranged in relation to the shoulder 12a and the annular seat 12b such that upon assembly of the stopper 10 onto the stopper-mounting member 12, as shown in FIG. 4, with the sealing flange 34 abutting the shoulder 12a and

4

the sealing ring 38 accommodated within the seat 12b, the inner wall 22 of the stopper 10 is placed into longitudinal compression to provide a tight seal against the stopper-mounting member 12. To this end the reinforcing or connecting ribs 30, 32 terminate short of the upper end of the stopper as defined by the upper face of the sealing flange 34 to provide an annular clearance space, generally designated by the reference numeral 40 in FIG. 4, such that the adjacent upper end 22a of the inner wall 22 may be flexed outwardly in response to such longitudinal compression.

From the foregoing it will be appreciated that there has been provided in accordance with the present invention an improved stopper assembly for a decanter bottle or like container which is of unitary construction such that it may be manufactured on a mass production basis at relatively low unit cost by injection molding from an appropriate plastic, such as polyethylene. The stopper is relatively impervious to attack by wines, whiskeys, liquors and the like and imparts minimal taste to such beverages. The stopper is of a construction which readily accommodates to the dispensing opening into which it is inserted, and although affording this requisite flexibility or resiliency, provides a fluid tight seal to its supporting member. The assembly of the stopper onto its supporting member involves a relatively simple manual operation; and incident to such assembly the requisite joinder of the stopper to its supporting member is achieved to virtually preclude leakage.

A latitude of modification, change and substitution is intended in the foregoing disclosure and in some instances some features of the invention will be employed without a corresponding use of other features. Accordingly, it is appropriate that the appended claims be construed broadly and in a manner consistent with the spirit and scope of the invention herein.

I claim:

1. For use in a decanter including a neck having a substantially cylindrical neck wall bounding a dispensing opening and a closure for said decanter including a depending stopper-mounting member, the improvement comprising a stopper fabricated of a resilient plastic mounted on said stopper-mounting member and adapted to provide a fluid-tight seal for said dispensing opening, said stopper including cylindrical inner and outer walls disposed in coaxial relation and cooperating to define an annular space therebetween, said inner wall being of a diameter to provide a tight fit over said stopper-mounting member and said outer wall being of a diameter to provide a tight fit within said neck wall, and a plurality of circumferentially spaced ribs bridging said annular space and interconnecting said inner and outer walls, said ribs being arranged relative to each other to permit radial compression of said outer wall about its circumferential extent to permit said stopper to accommodate to irregularities in said neck wall, said ribs being further arranged to provide a substantially uniform radial compressive strength about said inner and outer walls of said stopper.

2. For use in a decanter including a neck having a substantially cylindrical neck wall bounding a dispensing opening and a closure for said decanter including a depending stopper-mounting member, the improvement comprising a stopper fabricated of a resilient plastic mounted on said stopper-mounting member and adapted to provide a fluid-tight seal for said dispensing opening, said stopper including cylindrical inner and outer walls disposed in coaxial relation and cooperating to define an annular space therebetween, said inner wall being of a diameter to provide a tight fit over said stopper-mounting member and said outer wall being of a diameter to provide a tight fit within said neck wall, and a plurality of circumferentially spaced ribs bridging said annular space and interconnecting said inner and outer walls, said ribs being arranged relative to each other to permit radial compression of said outer wall about its circum-

5

ferential extent to permit said stopper to accommodate to irregularities in said neck wall, said ribs being arranged in pairs which are curved and in facing relation, each pair of ribs being positioned in relation to each other and of a curvature to lie on a common circle having a diameter greater than the spacing between said inner and outer walls.

3. In a decanter including a neck having a substantially cylindrical neck wall bounding a dispensing opening and a closure for said decanter including a depending stopper-mounting member having an annular seat adjacent the free end thereof and a shoulder spaced therefrom, a stopper fabricated of a resilient plastic mounted on said stopper-mounting member and adapted to provide a fluid-tight seal for said dispensing opening, said stopper including cylindrical inner and outer walls disposed in coaxial relation and cooperating to define an annular space therebetween, said inner wall being of a diameter to provide a tight fit over said stopper-mounting member and said outer wall being of a diameter to provide a tight fit within said neck wall, a plurality of circumferentially spaced ribs bridging said annular space and interconnecting said inner and outer walls, said ribs being arranged relative to each other to permit radial compression of said outer wall about its circumferential extent to permit said stopper to accommodate to irregularities in said neck wall, means providing an abutment adjacent one end of said stopper engaging said shoulder when said stopper is assembled on said stopper-mounting member, and means providing an annular seal adjacent the other end of said stopper engaged within said annular seat when said stopper is assembled on said stopper-mounting member, said abutment and annular seal being spaced in relation to said shoulder and rib respectively such that at least said inner wall of said stopper is placed into longitudinal compression when assembled on said stopper-mounting member to urge said inner wall into sealing contact with said stopper-mounting member.

4. In a decanter according to claim 3 wherein said neck wall terminates in an upper edge, said abutment provides a radially-extending sealing flange bearing against said upper edge when said closure is inserted in said dispensing opening.

5. In a decanter including a neck having a substantially cylindrical neck wall bounding a dispensing opening and a closure for said decanter including a depending stopper-mounting member having an annular seat adjacent the free end thereof and a shoulder spaced therefrom, a stopper fabricated of a resilient plastic mounted on said stopper-mounting member and adapted to provide a fluid-tight seal for said dispensing opening, said stopper including cylindrical inner and outer walls disposed in coaxial relation and cooperating to define an annular space therebetween, said inner wall being of a diameter to provide a tight fit over said stopper-mounting member and said outer wall being of a diameter to provide a tight fit within said neck wall, a plurality of circumferentially spaced ribs bridging said annular space and interconnecting said inner and outer walls, said ribs being arranged relative to each other to permit radial compression of said outer wall about its circumferential extent to permit said stopper to accommodate to irregularities in said neck wall, means providing an abutment adjacent one end of said stopper engaging said shoulder when said stopper is assembled on said stopper-mounting member, and means providing an annular seal adjacent the other end of said stopper engaged within said annular rib when said stopper is assembled on said stopper-mounting member.

6. In a decanter according to claim 5, said annular seal being provided by an annular sealing ring of a diameter less than the diameter of said inner wall of said closure.

7. In a decanter including a neck having a substantially cylindrical neck wall bounding a dispensing opening and a closure for said decanter including a depending stopper-mounting member having an annular seat adja-

6

cent the free end thereof and a shoulder spaced therefrom, a stopper fabricated of a resilient plastic mounted on said stopper-mounting member and adapted to provide a fluid-tight seal for said dispensing opening, said stopper including cylindrical inner and outer walls disposed in coaxial relation and cooperating to define an annular space therebetween, said inner wall being of a diameter to provide a tight fit over said stopper-mounting member and said outer wall being of a diameter to provide a tight fit within said neck wall, a plurality of circumferentially spaced ribs bridging said annular space and interconnecting said inner and outer walls, said ribs being arranged relative to each other to permit radial compression of said outer wall about its circumferential extent to permit said stopper to accommodate to irregularities in said neck wall, means providing an abutment adjacent one end of said stopper engaging said shoulder when said stopper is assembled on said stopper-mounting member, and means providing an annular seal adjacent the other end of said stopper engaged within said annular seat when said stopper is assembled on said stopper-mounting member, said abutment and annular seal being spaced in relation to said shoulder and seat respectively such that at least said inner wall of said stopper is placed into longitudinal compression when assembled on said stopper-mounting member to urge said inner wall into sealing contact with said stopper-mounting member, said ribs being arranged in pairs which are curved and in facing relation, each pair of ribs being positioned in relation to each other and being of a curvature to lie on a common circle having a diameter greater than the spacing between said inner and outer walls.

8. For use in a decanter including a neck having a substantially cylindrical neck wall bounding a dispensing opening and a closure for said decanter including a depending stopper-mounting member, the improvement comprising a stopper fabricated of a resilient plastic mounted on said stopper-mounting member and adapted to provide a fluid-tight seal for said dispensing opening, said stopper including cylindrical inner and outer walls disposed in coaxial relation and cooperating to define an annular space therebetween, said inner wall being of a diameter to provide a tight fit over said stopper-mounting member and said outer wall being of a diameter to provide a tight fit within said neck wall, and a plurality of circumferentially spaced ribs bridging said annular space and interconnecting said inner and outer walls, said ribs being arranged relative to each other to permit radial compression of said outer wall about its circumferential extent to permit said stopper to accommodate to irregularities in said neck wall, said ribs being arranged in pairs which are curved and in facing relation, each pair of ribs being positioned in relation to each other and of a curvature to lie substantially on a common circle with each pair of ribs merging into said inner and outer walls, said pairs of ribs providing a substantially uniform radial compressive strength about said inner and outer walls of said stopper.

9. In a decanter including a neck having a substantially cylindrical neck wall bounding a dispensing opening and a closure for said decanter including a depending stopper-mounting member having an annular seat adjacent the free end thereof and a shoulder spaced therefrom, a stopper fabricated of a resilient plastic mounted on said stopper-mounting member and adapted to provide a fluid-tight seal for said dispensing opening, said stopper including cylindrical inner and outer walls disposed in coaxial relation and cooperating to define an annular space therebetween, said inner wall being of a diameter to provide a tight fit over said stopper-mounting member and said outer wall being of a diameter to provide a tight fit within said neck wall, a plurality of circumferentially spaced pairs of curved ribs bridging said annular space and interconnecting said inner and outer walls, said pairs of ribs being arranged relative to each other to permit radial compression

7

sion of said outer wall about its circumferential extent to permit said stopper to accommodate to irregularities in said neck wall, means providing an abutment adjacent one end of said stopper engaging said shoulder when said stopper is assembled on said stopper-mounting member, and means providing an annular seal adjacent the other end of said stopper engaged within said annular seat when said stopper is assembled on said stopper-mounting member, each pair of ribs being positioned in relation to each other and being of a curvature to lie substantially on a common circle with each pair of ribs merging into

5

10

8

said inner and outer walls, said pairs of ribs providing a substantially uniform radial compressive strength about said inner and outer walls of said stopper.

**References Cited** in the file of this patent

FOREIGN PATENTS

|           |               |               |
|-----------|---------------|---------------|
| 860,761   | Germany ----- | Dec. 22, 1952 |
| 1,038,817 | France -----  | May 13, 1953  |
| 550,910   | Italy -----   | Nov. 14, 1956 |
| 1,173,823 | France -----  | Oct. 27, 1958 |