

No. 606,826.

Patented July 5, 1898.

C. A. TERRY & H. P. DAVIS.

CURRENT COLLECTING APPARATUS FOR ELECTRIC RAILWAYS.

(Application filed Apr. 6, 1896.)

(No Model.)

2 Sheets—Sheet 1.

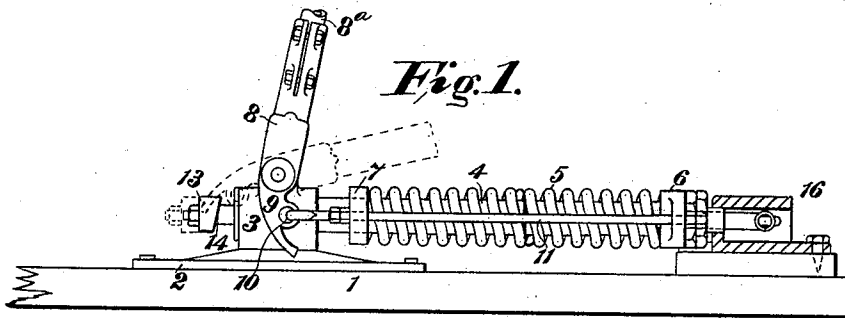

Fig. 1.

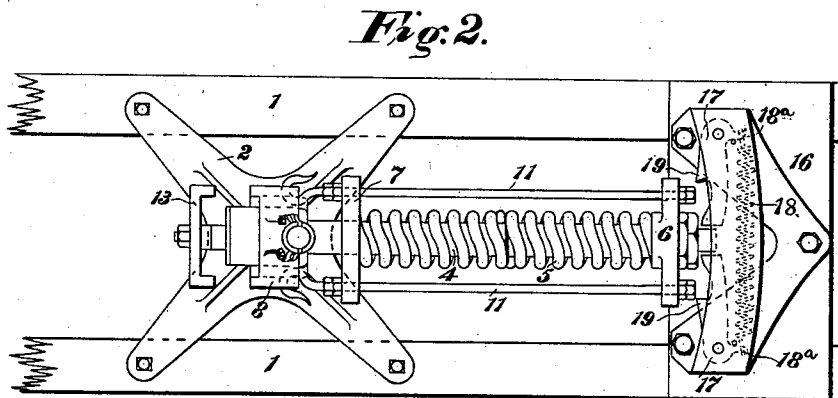

Fig. 2.

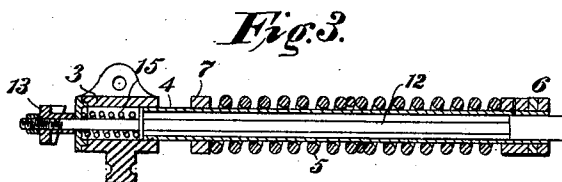

Fig. 3.

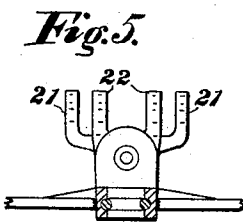

Fig. 5.

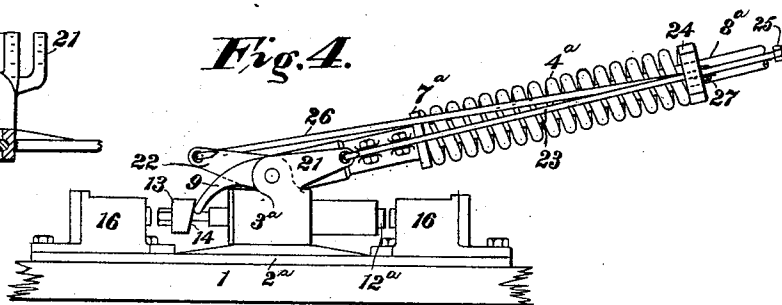

Fig. 4.

WITNESSES:

Ethan S. Dadds
Hubert C. Toner

INVENTORS.

Charles A. Terry
Harry P. Davis
BY
O. G. Swan
ATTORNEY.

No. 606,826.

Patented July 5, 1898.

C. A. TERRY & H. P. DAVIS.

CURRENT COLLECTING APPARATUS FOR ELECTRIC RAILWAYS.

(Application filed Apr. 6, 1896.)

(No Model.)

2 Sheets—Sheet 2.

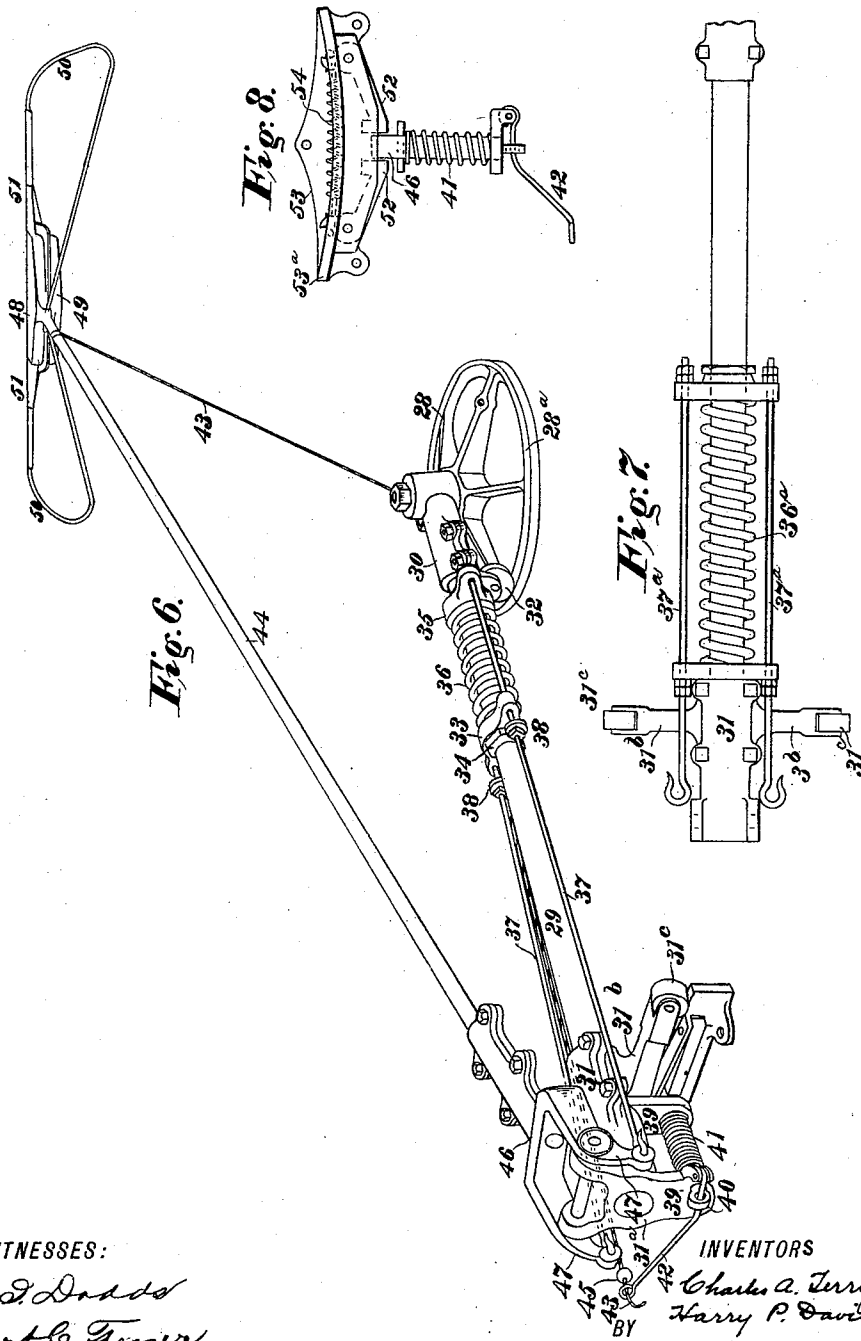

WITNESSES:

Chas. J. Dadds
Douglas C. Fenner

INVENTORS

Charles A. Terry
Harry P. Davis

H. C. Carr
ATTORNEY.

UNITED STATES PATENT OFFICE.

CHARLES A. TERRY, OF NEW YORK, N. Y., AND HARRY P. DAVIS, OF PITTSBURG, PENNSYLVANIA, ASSIGNORS TO THE WESTINGHOUSE ELECTRIC AND MANUFACTURING COMPANY, OF PITTSBURG, PENNSYLVANIA.

CURRENT-COLLECTING APPARATUS FOR ELECTRIC RAILWAYS.

SPECIFICATION forming part of Letters Patent No. 606,826, dated July 5, 1898.

Application filed April 6, 1896. Serial No. 586,286. (No model.)

To all whom it may concern:

Be it known that we, CHARLES A. TERRY, residing in the city of New York, county and State of New York, and HARRY P. DAVIS, residing in the city of Pittsburg, county of Allegheny, State of Pennsylvania, citizens of the United States, have invented a new and useful Improvement in Current-Collecting Apparatus for Electric Railways, (Case No. 695,) of which the following is a specification.

Our invention relates to apparatus employed for collecting current from supply-conductors for the operation of electrically-propelled vehicles, and more particularly to the supporting means for the contact device and its supporting-arm.

The object of the invention is to provide a simple and efficient means whereby the contact device and its supporting-arm may be yieldingly supported and retained at any desired elevation and whereby these parts may be locked in position, so that they will have no sidewise or lateral motion with reference to the vehicle when in operation.

A further object of the invention is to provide means whereby the lowering of the contact device will automatically unlock or release the supporting-base and permit of its swinging in a horizontal plane and automatically lock it against lateral movement when in its reverse position.

In the accompanying drawings, Figure 1 is a view, partially in side elevation and partially in section, of a portion of the top of the car with our supporting-base mounted thereon. Fig. 2 is a plan view of the parts shown in Fig. 1; and Fig. 3 is a longitudinal section of a portion of the base, showing the locking-bolt and its actuating-spring. Fig. 4 is a side elevation of a modified construction; and Fig. 5 is an end elevation of the central casting, to which the contact-supporting arm is hinged. Fig. 6 is a perspective view of an apparatus of modified construction. Fig. 7 is a plan view of a further modification of a reversible support. Fig. 8 is a plan view of a modified form of the locking device for the reversible support.

Referring to Figs. 1 to 3 of the drawings, 1 is a portion of the top of a car, and 2 is a sup-

porting-plate, this plate being preferably located at the center of the car. Pivotaly mounted upon the plate 2 is a hollow casting 3, from one end of which projects a tubular extension 4, said casting and extension constituting a reversible support for the contact and its arm. Surrounding the extension 4 is a coiled spring 5, which for convenience of construction will ordinarily be in two parts, abutting end to end, substantially as indicated in the drawings. At its outer end this spring 5 bears against a head 6, which is mounted upon the extension 4, so as to slide freely thereon, and at its inner end the spring bears against a head 7, which is rigidly mounted upon said extension. 8 is a socket-clamp for the reception of the lower end of the contact-carrying arm 8^a, these parts constituting the supporting-arm, upon the free end of which is mounted the contact device. (Not shown.) The socket 8 is pivotaly mounted in the casting 3, so as to move in a vertical plane, and is provided with projections 9, which extend downward below the pivot-bearing and have curved cam-faces, as indicated in the drawings. Each of the projections 9 is provided with a hole or opening 10, with which the hooked end of a tension-rod 11 engages. These rods 11 extend through openings in the heads 6 and 7 and are provided with suitable nuts, as indicated. 12 is a bolt or rod which extends through the casting 3 and the tubular extension 4, and the end projecting beyond the casting 3 is provided with a head 13, having inclined inner faces 14, with which the cam-faces of the projections 9 engage when the contact-supporting arm is moved a sufficient distance from a vertical position. 15 is a coiled spring located in the casting 3, which serves to normally press the bolt 12 outward. 16 is a locking device, there being two of these devices located in alignment with and on opposite sides of the casting 3, lengthwise of the car, so as to automatically lock the reversible support in either of its extreme positions, as may be desired. This locking device consists of a skeleton casting suitably bolted to the top of the car, inside of which are mounted two locking-dogs 17, projecting inwardly toward each other, their inner free

ends being a sufficient distance apart to afford a space for the reception of the end of the bolt 12. These dogs 17 are normally pressed outward by means of a coiled spring 18 (shown in dotted lines in Fig. 2) and connecting-lugs 18^a, projecting laterally from the outer ends of the dogs. Each of the dogs is provided with an auxiliary tooth or projection 19, which will engage the end of the bolt 12 and prevent the support from swinging outward away from the locking device in case the bolt should not be moved far enough to drop into the space between the ends of the dogs, and thus lock it in its proper position.

In Figs. 4 and 5 we have shown a slightly-modified construction in which the elevating and supporting spring 4^a is mounted upon the contact-bearing arm or pole 8^a. In this form of the device a shorter locking-bolt 12^a may be employed, and the locking devices 16 consequently may be mounted much nearer to the center of the supporting-plate 2^a and the casting 3^a. In this form the casting 2^a is preferably provided with two pairs of arms 21 and 22, which are rigid therewith and may conveniently form integral parts thereof. The arms 21 are connected by means of rods 23 with a head 24, loosely mounted on the pole 8^a. These rods 23 project through openings in the head 24, which are of sufficient size to permit the rods to move freely therein, and are provided with check-nuts 25, so located as to engage with the head 24 and stop the upward movement of the arm 8^a before it quite reaches the vertical position. Tension-rods 26 extend from the ends of the arms 22 through suitable openings in the head 24 and are provided with nuts 27. These parts, in conjunction with the spring 4^a, serve to exert the necessary tension upon the supporting-arm 8^a and hold the same up in any desired angular position. The projection 9 and the head 13, having the inclined faces 14, are substantially the same in construction as the corresponding parts shown in the other figures.

Referring now to the modification shown in Fig. 6, 28 is a skeleton casting which is designed to be bolted or otherwise securely fastened to the top of the car, midway of its ends. 29 is a horizontal rod or tube, preferably the latter, the inner end of which is clamped in a socket 30, and the outer end of which is clamped in a socket 31. The socket 30 is pivotally mounted upon the casting 28 and is preferably provided with a roller 32, which engages with an annular track 28^a around the outer edge of the casting 28. 33 is a stationary collar mounted upon the tube 29 and abutting against a nut 34 or other suitable stop. A collar 35 is loosely mounted upon the tube 29, and interposed between the collars 33 and 35 is a coiled spring 36. Two rods 37, one on each side of the tube 29, extend through suitable openings in the collars 34 and 35 and are rigidly fastened to the lat-

ter, preferably by means of set-nuts. These rods are also provided with stops 38, (shown in the drawings as nuts and washers,) located in such position as to engage the collar 33 when the contact device reaches its maximum elevation. The clamping-sleeve 31 constitutes a portion of a head 31^a, provided with downwardly-projecting lugs 39, in which is mounted a sliding bolt 40. The head 31^a is also provided with two laterally-projecting arms 31^b, in the outer end of each of which is mounted a roller 31^c, the purpose of which will be hereinafter described. A coiled spring 41 is mounted upon the bolt 40 and serves to press the same inwardly. A lever 42 is pivoted at one end to one of the lugs 39 and extends through an eye in the outer end of the bolt 40. The outer end of the lever 42 is provided with an eye, through which extends a cord 43. This cord 43 extends through or over suitable bearings (not shown) to the outer end of the supporting-arm 44 and is provided with a suitable enlargement, which may be a knot in the cord or a ball or button 45, as indicated in the drawings. The arm 44 is clamped at its lower or inner end in the socket of a casting 46. This casting is pivoted to the head 31^a and is provided with arms or lugs 47, which project downward beyond its pivot-bearing. The ends of the rods 37 engage with the ends of the arms or lugs 47 by means of hooks, as indicated in the drawings. The contact-head comprises a central roller 48, a supporting-frame 49 therefor, lateral extensions 50, which serve as guard-pieces and braces, and stationary wearing-pieces 51, which serve to make the necessary electrical contact with the overhead conductor if there should be at any time sufficient lateral movement with reference to the conductor to carry the contact-roller out of engagement with such conductor. This form of contact device is not claimed herein, but forms in part the subject of an application, Serial No. 581,493, filed by us March 2, 1896. The locking-bolt 40 is intended to engage a locking device like or similar to that shown in Fig. 8. This locking device is similar to the device 16, (shown in Fig. 2,) and comprises two dogs 52, mounted in a suitable casting 53 and normally pressed outward by means of a coiled spring 54. The casting 53 is provided with a curved track 53^a, the curvature of which corresponds to the arc of a circle of which the pivot of the boom is the center. The rollers 31^c engage this track when the boom is swung into its normal position and facilitate the movement of the head 31^a, and also afford an extended bearing-surface which tends to prevent objectionable rocking of the contact device and its supporting-arm when locked in operative position. One of these stationary locking devices is mounted upon each side of the casting 28, longitudinally of the car, at such a distance therefrom that the bolt 40 will automatically slip into position between the two dogs when the boom is swung into proper position at either

end of the car. This particular locking mechanism forms no part of our present invention and is not claimed herein. The projection or enlargement 45 is located in such position upon the cord 43 that the arm 44 will be drawn down by means of the cord to nearly a horizontal position before the enlargement engages with the end of the lever 42 to withdraw the locking-bolt 40 from its socket. When the locking-bolt is thus withdrawn, the boom and the devices carried thereby may be readily swung around into reversed position by means of the cord, as will be readily understood.

In the modification shown in Fig. 7 the construction is substantially the same as that shown in Fig. 6, except that short rods 37^a are employed and the spring 36^a is located near the outer end of the boom. The construction and operation of the two forms are otherwise the same.

We desire it to be understood that the form, dimensions, and relative arrangement of the several parts shown and described may be varied without departing from the invention.

We claim as our invention—

1. In a current-collector for railway-vehicles mounted to turn upon two axes substantially at right angles to each other, a locking device normally serving to prevent movement upon one of said axes and means actuated by said collector to unlock the same upon its movement a predetermined distance in one direction on the other axis.

2. In a current-collector for railway-vehicles mounted to turn upon a vertical axis, a locking device normally acting to prevent such turning movement and means actuated by the downward movement of the collector to release the same from the locking device.

3. The combination with a contact-supporting arm and a pivoted base to which said arm is hinged, of means for pressing said arm upwardly, a locking device normally acting to hold said base against movement and means actuated by the downward movement of said arm to release said base.

4. The combination with a contact-supporting arm and a pivoted base to which said arm is hinged, of a locking device normally acting to hold said base against movement on its pivot, and means actuated by the downward movement of said arm to unlock said base.

5. The combination with a device for making contact with overhead conductors, its supporting-arm and a reversible base or support therefor, of a spring-actuated locking-bolt, a device projecting laterally therefrom and means connected with the contact-supporting arm for engagement with said device to withdraw the bolt when the arm is lowered a predetermined amount.

6. The combination with a supporting-arm for overhead contact devices, of a reversible support pivoted to swing in a horizontal plane and provided with a spring-actuated locking-bolt, a head projecting laterally from one end of said bolt and a cam-faced projection connected to and movable with the supporting-arm to engage said head and withdraw the bolt when the supporting-arm is depressed a predetermined amount.

7. The combination with a supporting-arm for overhead contact devices, a pivoted casting to which the lower end of said arm is hinged, and a tube extending laterally from the said casting, of a coiled spring surrounding said tube, a movable head engaging one end of said spring, means connecting said head with lugs projecting from the supporting-arm below its hinge or pivot, a locking-bolt extending through the said casting and its tube and provided with a head with which the projections on the supporting-arm engage to withdraw the bolt when the arm is lowered.

8. The combination with hollow casting pivoted to swing in a horizontal plane, of a tubular extension projecting horizontally from one end of said casting, a spring-actuated locking-bolt extending through said casting and extension and provided at one end with a laterally-projecting head, spring-actuated dogs for engagement with the opposite ends of said locking-bolt, a contact-supporting arm pivoted or hinged to said casting, and provided with cam-faced projections for engagement with the laterally-projecting head on the locking-bolt, and means cooperating with said projections for elevating said contact-supporting arms.

9. The combination with a contact-supporting arm and a reversible supporting-base to which said arm is hinged, of means for elevating said arm, a spring-actuated locking-bolt carried by said support and having a laterally-projecting head and means projecting from said arm to engage the bolt-head and withdraw the bolt when the arm is depressed.

In testimony whereof I, the said CHARLES A. TERRY, have subscribed my name this 30th day of March, A. D. 1896.

CHARLES A. TERRY.

Witnesses:

T. N. WATERMAN,
WILLIAM WILKE.

In testimony whereof I, the said HARRY P. DAVIS, have hereunto subscribed my name this 1st day of April, A. D. 1896.

HARRY P. DAVIS.

Witnesses:

WESLEY G. CARR,
HUBERT C. TENER.