



(43) International Publication Date
31 October 2019 (31.10.2019)

(51) International Patent Classification:

H04L 12/28 (2006.01) H04W 80/02 (2009.01)
H04L 9/32 (2006.01) H04W 84/00 (2009.01)

(21) International Application Number:

PCT/CA2019/050527

(22) International Filing Date:

25 April 2019 (25.04.2019)

(25) Filing Language:

English

(26) Publication Language:

English

(30) Priority Data:

62/662,464 25 April 2018 (25.04.2018) US

(71) Applicant: **FLIR UNMANNED AERIAL SYSTEMS ULC** [CA/CA]; Suite 2600, Three Bentall Centre, 595 Bur-

ard Street, P.O. Box 49314, Vancouver, British Columbia V7X 1L3 (CA).

(72) Inventors: **PREST, Christopher E.**; 552 Wasaga Crescent, Waterloo, Ontario N2V 2Y7 (CA). **KROETSCH, David Daniel**; 242 Cheltonwood Crescent, Waterloo, Ontario N2V 1X9 (CA). **PEASGOOD, Michael**; 209 Royal Street, Waterloo, Ontario N2J 2H8 (CA). **MAILLOUX, Jerry**; 1368 Greenwood Hill, Waterloo, Ontario N0B 2T0 (CA). **CHOO, Eason Jay**; 564 Killbear Court, Waterloo, Ontario N2V 2R9 (CA).

(74) Agent: **NORTON ROSE FULBRIGHT CANADA LLP / S.E.N.C.R.L., S.R.L.**; 1 Place Ville Marie, Suite 2500, Montreal, Québec H3B 1R1 (CA).

(81) Designated States (unless otherwise indicated, for every kind of national protection available): AE, AG, AL, AM, AO, AT, AU, AZ, BA, BB, BG, BH, BN, BR, BW, BY, BZ, CA, CH, CL, CN, CO, CR, CU, CZ, DE, DJ, DK, DM, DO,

(54) Title: SYSTEMS AND METHODS FOR COMMUNICATING WITH PAYLOAD ON AN UNMANNED VEHICLE

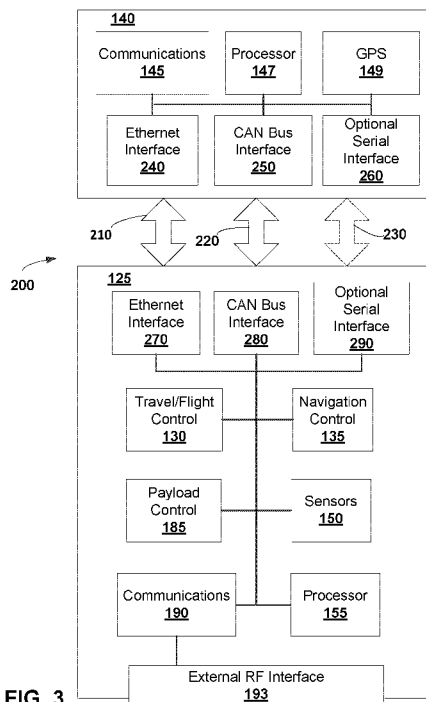

FIG. 3

(57) Abstract: An unmanned vehicle (UV) is provided for transmitting data to a payload device connected to the UV. The UV comprises a processor configured to control operations of the UV, a first and a second communication interface for connecting to a payload device, a third communication interface for communicating with a remote station, and a non-transitory memory device storing instructions configured to cause the processor to receive and transmit data. The processor is configured to receive one or more data packets through the third communication interface from the remote station, transmit the one or more data packets to the payload device through the first communication interface when the one or more data packets are designated for the first communication interface, and transmit the one or more data packets to the payload device through the second communication interface when the one or more data packets are designated for the second communication interface.



DZ, EC, EE, EG, ES, FI, GB, GD, GE, GH, GM, GT, HN, HR, HU, ID, IL, IN, IR, IS, JO, JP, KE, KG, KH, KN, KP, KR, KW, KZ, LA, LC, LK, LR, LS, LU, LY, MA, MD, ME, MG, MK, MN, MW, MX, MY, MZ, NA, NG, NI, NO, NZ, OM, PA, PE, PG, PH, PL, PT, QA, RO, RS, RU, RW, SA, SC, SD, SE, SG, SK, SL, SM, ST, SV, SY, TH, TJ, TM, TN, TR, TT, TZ, UA, UG, US, UZ, VC, VN, ZA, ZM, ZW.

(84) Designated States (*unless otherwise indicated, for every kind of regional protection available*): ARIPO (BW, GH, GM, KE, LR, LS, MW, MZ, NA, RW, SD, SL, ST, SZ, TZ, UG, ZM, ZW), Eurasian (AM, AZ, BY, KG, KZ, RU, TJ, TM), European (AL, AT, BE, BG, CH, CY, CZ, DE, DK, EE, ES, FI, FR, GB, GR, HR, HU, IE, IS, IT, LT, LU, LV, MC, MK, MT, NL, NO, PL, PT, RO, RS, SE, SI, SK, SM, TR), OAPI (BF, BJ, CF, CG, CI, CM, GA, GN, GQ, GW, KM, ML, MR, NE, SN, TD, TG).

Published:

— *with international search report (Art. 21(3))*

SYSTEMS AND METHODS FOR COMMUNICATING WITH PAYLOAD ON AN UNMANNED VEHICLE

CROSS-REFERENCE TO RELATED APPLICATIONS

[0001] This application claims all benefit including priority to United States Provisional Patent Application 62/662,464, filed April 25, 2018, and entitled: "Systems and Methods for Communicating with Payload on an Unmanned Aerial Vehicle," which is hereby incorporated by reference in its entirety.

FIELD

[0002] This disclosure generally relates to the field of unmanned vehicles, and in particular to communication with an unmanned vehicle and its payload.

BACKGROUND

[0003] An unmanned aerial vehicle (UAV) does not have a human operator located at the UAV. A UAV may include various components such as sensors and measurement and navigation instruments. A UAV may carry a payload which may be configured to perform specific duties such delivering packages or taking aerial photographs and videos. Often times when a payload is designed to be used with a UAV, the manufacturer of either the UAV or the payload would need to spend considerable amount of time and resources on customizing the hardware and software of the payload and/or the UAV (e.g., a driver program on UAV for the payload), so a user can control or communicate with the payload or the UAV via the remote control station or device while the payload is in the air. It is describe to allow a user to communicate or control a payload in the air without requiring extensive customization of the hardware and software of the payload and UAV.

[0004] Accordingly, there exists a need for an improved communication with payloads on UAVs, or at least an alternative.

SUMMARY

[0005] In accordance with one aspect, there is provided an unmanned vehicle (UV). The UV comprises a processor configured to control operations of the UV, a first communication interface and a second communication interface for connecting to a payload device, the first and second communication interfaces being of different types from each other, a third communication interface for communicating with a remote station, and a non-transitory memory device storing machine-readable instructions that, when executed by the

processor, causes the processor to receive and transmit data. The processor is configured to receive through the third communication interface one or more data packets from the remote station, transmit the one or more data packets to the payload device through the first communication interface when the one or more data packets are designated for the first communication interface, and transmit the one or more data packets to the payload device through the second communication interface when the one or more data packets are designated for the second communication interface.

[0006] In accordance with another aspect, a process for receiving and transmitting data by an unmanned vehicle (UV) is provided. The UV comprises a first communication interface and a second communication interface for connecting to a payload device, and a third communication interface for communicating with a remote station. The first and second communication interfaces are of different types from each other. The process comprises receiving through the third communication interface one or more data packets from the remote station, transmitting the one or more data packets to the payload device through the first communication interface when the one or more data packets are designated for the first communication interface, and transmitting the one or more data packets to the payload device through the second communication interface when the one or more data packets are designated for the second communication interface.

[0007] In accordance with one aspect, a remote station may be provided. The remote station comprises a processor, a communication interface for communicating with an unmanned vehicle (UV), and a non-transitory memory device storing machine-readable instructions that, when executed by the processor, cause the processor to receive and transmit data. The processor is configured to receive or retrieve an input, process the input into one or more data packets for transmission to a payload device through the UV when the input is for the payload device connected to the UV, and transmit the one or more data packets to the UV through the communication interface for delivery to the payload device. The payload device is connected to the UV through at least two communication interfaces. The two communication interfaces are of different types from each other.

[0008] In accordance with another aspect, a software development kit (SDK) may be provided. The SDK may be stored on a non-transitory computer readable medium for developing software applications for controlling an unmanned vehicle (UV) and a payload device connected to the UV. The UV may comprise a UAV, UGV, unmanned aquatic vehicle, or any robotic structure (including a fixed structure). The SDK comprises a first application programming interface (API) utilized in developing software applications at a remote station, and a second API utilized in developing the software applications at a remote station. The first API is configured to access the UV to obtain information regarding the UV. The second

API is configured to access the payload device to obtain information regarding the payload device. The second API is configured to access the payload device through a communication interface between the remote station and the UV.

[0009] In various further aspects, the disclosure provides corresponding systems and devices, and logic structures such as machine-executable coded instruction sets for implementing such systems, devices, and methods.

[0010] In this respect, before explaining at least one embodiment in detail, it is to be understood that the embodiments are not limited in application to the details of construction and to the arrangements of the components set forth in the following description or illustrated in the drawings. Also, it is to be understood that the phraseology and terminology employed herein are for the purpose of description and should not be regarded as limiting.

[0011] Many further features and combinations thereof concerning embodiments described herein will appear to those skilled in the art following a reading of the instant disclosure.

DESCRIPTION OF THE FIGURES

[0012] Embodiments will be described, by way of example only, with reference to the attached figures, wherein in the figures:

[0013] **FIG. 1** is a schematic view of an example system for an UV, in accordance with some embodiments;

[0014] **FIG. 2** is a schematic block diagram of an example system of UVs or UAVs in communication with a ground station and client devices, in accordance with some embodiments;

[0015] **FIG. 3** is a schematic block diagram of an example system of a loaded vehicle including a payload and an UV or UAV, in accordance with some embodiments;

[0016] **FIG. 4** is a schematic block diagram of an example ground station, in accordance with some embodiments;

[0017] **FIG. 5A** is a schematic block diagram of an example client device, in accordance with some embodiments;

[0018] **FIG. 5B** is a block diagram illustrating hardware components of an example client device, in accordance with some embodiments;

[0019] **FIG. 6** is a flow chart illustrating an example process of communicating with a payload through an UV or UAV, in accordance with some embodiments;

[0020] FIG. 7 is a flow chart illustrating an example process of processing input, by a remote station, for transmission to a payload device, in accordance with some embodiments;

[0021] FIG. 8 is a schematic block diagram of an example system of an UV or UAV in communication with a ground station and a client device with IP addresses, in accordance with some embodiments; and

[0022] FIG. 9 shows an example data packet prepared by a remote station for transmission to a payload connected to a UV or UAV, in accordance with some embodiments.

[0023] It is understood that throughout the description and figures, like features are identified by like reference numerals.

DETAILED DESCRIPTION

[0024] It will be appreciated that numerous specific details are set forth in order to provide a thorough understanding of the exemplary embodiments described herein. However, it will be understood by those of ordinary skill in the art that the embodiments described herein may be practiced without these specific details. In other instances, well-known methods, procedures and components have not been described in detail so as not to obscure the embodiments described herein. Furthermore, this description is not to be considered as limiting the scope of the embodiments described herein in any way, but rather as merely describing implementation of the various example embodiments described herein.

[0025] The term unmanned vehicle (UV) is used herein and may include an unmanned aerial vehicle (UAV), an unmanned aircraft (UA), an unmanned aquatic vessel, an unmanned ground vehicle (UGV), and any other vehicle or structure which maybe unmanned, operate autonomously or semi-autonomously, and/or controlled remotely. The UGV may be a remotely controlled, autonomous or semi-autonomous vehicle system which is comprised of a main body and a drive system supported by the main body. In some examples, the drive system is comprised of a propulsion system, such as a motor or engine, and one or more tracks or wheels. Other arrangements, such as a rail or fixed-track ground vehicle, a tether or rope-pulled ground vehicle without a motor or engine, a ground vehicle using balls, sleds or rails, and a ground vehicle which hovers but navigates in proximity to terrain, are also contemplated herein.

[0026] Some of the features taught herein are described with reference to embodiments of a UAV by way of example only. However, the description and features may also apply generally to any UV.

[0027] **FIG. 1** illustrates an unmanned system (US) **10** (such as an unmanned aircraft system) comprising an unmanned vehicle (UV) **125** (such as an unmanned aerial vehicle) and its associated system elements. UV **125** is designed to operate with no operator (or pilot) onboard. In the embodiment shown in **FIG. 1**, the unmanned system **10** includes a remote operator (or pilot) station **14** and command and control links **16** between UV **125** and remote operator (or pilot) station **14**. The command and control links **16** may include any data link for the purposes of managing the travel or movement (e.g., flight) of UV **125**. UV **125** may operate autonomously without operator (e.g., pilot) intervention in the management of the travel or movement (e.g., flight) during the entire travel or movement (e.g., flight) operation or a portion thereof. The unmanned system **10** may also include other system elements as may be required at any point during travel or movement (e.g., flight) operation.

[0028] In some embodiments, UV **125** may be an unmanned aircraft (UA) or UAV as shown in **FIG. 1**.

[0029] The example UV **125** shown in **FIG. 1** comprises a UAV that includes a body **18**, arms **20** extending away from the body **18** to support components such as propellers **22**, and legs **24** to support the body **18** when UV **125** is positioned on a surface. Although four arms **20** and four legs **24** are illustrated in the embodiment shown in **FIG. 1**, it is understood that UV **125** may include any other number of arms **20** and legs **24**. As noted above, the example of **FIG. 1** pertains to a UAV by way of example only. Similarly, the examples herein refer to UAVs. Other types of UVs may also employ the teachings described herein. As such, the terms UV or UAV **125** may be used. In some embodiments, the UV or UAV may be a fixed-wing UAV.

[0030] In some embodiments, remote pilot (or operator) station **14** may comprise a ground station. In other embodiments, remote pilot (or operator) station **14** may comprise a client device acting as a control station. In still other embodiments, remote pilot (or operator) station **14** may comprise both a ground station and a client device.

[0031] **FIG. 2** shows an example system **30** including one or more loaded vehicle **200**, a ground station **160**, and one or more client devices **105**. System **30** may include more than one ground stations **160**. A loaded vehicle **200** may include an UV or UAV **125** and a payload **140**. Ground station **160** may communicate with one or more loaded vehicles **200** via air interface **50**, which may include satellite communication **34** or other types of radio frequency communication **35** between station **160** and loaded vehicles **200**. Ground station **160** may communicate with one or more client devices **105** through a number of communication links and network interfaces, such as a wired or wireless local area network **31**, a cellular network **32** (such as Global System for Mobile Communications (GSM), Long-

Term Evolution (LTE), Fifth Generation (5G), or any other cellular networks), or a proprietary or private radio link **33**.

[0032] A loaded vehicle **200** may include an UV or UAV **125** and a payload **140**. The payload **140** may include one or more of: a freight package, a camera, a measuring device, one or more sensors, and a storage device (e.g., Universal Serial Bus (USB) drive). A payload **140** can also include, for example, flame retardant for use in a forest fire. Generally speaking, a payload **140** may be any cargo or equipment an UV or UAV **125** carries that is not necessarily required for flight, control, movement, transportation and/or navigation of the UV or UAV itself. A payload **140** may be attached or coupled to UV or UAV **125** in a number of ways. For example, a payload **140** may be connected to UV or UAV **125** by one or more interfaces such as, but not limited to, Ethernet connection, Controller Area Network (CAN) Bus connection, serial connection, Inter-integrated Circuit (I²C) connection, printed circuit board (PCB) interfaces, USB connection, a proprietary physical link, and so on. In some embodiments, the payload **140** may be connected to the UV or UAV **125** by a wireless connection such as, but not limited to, Bluetooth, WiFi, or any other wireless protocol.

[0033] Ground station **160** may be configured to communicate with one or more loaded vehicles **200** (or simply “vehicles **200**” hereinafter). Ground station **160** may also communicate with UVs or UAVs not carrying any payload. Ground station **160** may control one or more loaded vehicles **200**, one or more UVs or UAVs **125**, one or more payloads **140** concurrently in real time or near real time. Ground station **160** may also receive commands and/or data from one or more client devices **105**, process the commands or data, and transmit the processed commands or data to one or more vehicles **200**, UVs or UAVs **125**, or payloads **140**. In some embodiments, ground station **160** may receive user input directly without client devices **105**.

[0034] Client device **105** may serve to control the operation of one or more vehicles **200**, UVs or UAVs **125**, or payloads **140** remotely. In some embodiments, a client device **105** may also be referred to as a control station. Client device **105** may be implemented as a computing device.

[0035] A user, such as an owner or operator of an UV or UAV **125**, may use client device **105** to communicate with and control one or more vehicles **200**, UVs or UAVs **125**, or payloads **140**. A client device **105** may have an application implemented for communicating with or controlling vehicles **200**, UVs or UAVs **125**, or payloads **140**. Such an application may be launched as a stand-alone process in a standard operation system (e.g., Windows™ or Solaris™), or within a standard browser (e.g., Internet Explorer™ or Chrome™). The user may enter information through an user interface provided by the application. In addition,

information relating to or from the vehicle **200**, UV or UAV **125**, or payload **140** may be displayed by the application on a display of client device **105**. Client device **105** may communicate with or control vehicle **200**, UV or UAV **125**, or payload **140** through ground station **160**, or in some embodiments, client device **105** may communicate with or control vehicle **200**, UV or UAV **125**, or payload **140** directly without ground station **160**.

[0036] In some embodiments, client device **105** is operable to register and authenticate users (using a login, unique identifier, biometric information or password for example) prior to providing access to loaded vehicles, payloads, UVs or UAVs, applications, a local network, network resources, other networks and network security devices. Client device **105** may serve one user or multiple users.

[0037] In some embodiments, communication hardware and communication links (e.g., communication links **31**, **32**, **33**) may include a network interface to enable computing device to communicate with other components, to exchange data with other components, to access and connect to network resources, to serve applications, and perform other computing applications by connecting to a network (or multiple networks) capable of carrying data including the Internet, Ethernet, plain old telephone service (POTS) line, public switch telephone network (PSTN), integrated services digital network (ISDN), digital subscriber line (DSL), coaxial cable, fiber optics, satellite, mobile, wireless (e.g., Wi-Fi, WiMAX), SS7 signaling network, fixed line, local area network, wide area network, and others, including any combination of these.

[0038] Either or both of ground station **160** and client device **105** may be configured to control vehicle **200**, UV or UAV **125**, or payload **140**. Flight control, travel control, navigation control, movement, transportation, and other types of command signals may be transmitted to UV or UAV **125** for controlling or navigating one or more of vehicle **200**, UV or UAV **125**, or payload **140**. Command signals may include command data (e.g., coordinate information) required to execute travel control, flight control, movement control or navigation control of one or more of vehicle **200**, UV or UAV **125**, or payload **140**.

[0039] Either or both of ground station **160** and client device **105** may be configured to receive data from one or more of vehicle **200**, UV or UAV **125**, or payload **140**. For example, payload **140** may transmit audio, video or photographs to ground station **160** or client device **105**.

[0040] FIG. 3 is a schematic block diagram of an example system of a loaded vehicle **200** including a payload **140** and an UV or UAV **125** according to some embodiments. Payload **140** and UV or UAV **125** may be connected by one or more communication interfaces **210**, **220**, **230**, which may also be referred to as connection

interfaces herein. The one or more communication interfaces may be different interfaces. For example, each of communication interfaces **210**, **220**, **230** may be one of: Ethernet interface, Controller Area Network (CAN) Bus interface, serial connection interface, Inter-integrated Circuit (I²C) connection interface, printed circuit board (PCB) interface, USB connection interface, and a proprietary physical link. Communication interface **220** may be different from communication interface **210**. Data packets can be transmitted bi-directionally via one or more of communication interfaces **210**, **220**, **230**.

[0041] In some example embodiments, communication interface **210** is an Ethernet interface, and communication interface **220** is a CAN Bus interface. In some embodiments, there is a third, optional communication interface **230** which is a serial connection interface. The Ethernet interface **210** may comprise, for example, a Gigabit Ethernet physical layer.

[0042] Payload **140** may include a communication module for each of communication interface **210**, **220**, **230**. For example, payload **140** may include an Ethernet interface communication module **240**, a CAN Bus interface communication module **250** and a serial interface communication module **260**. Each of the communication interface modules **240**, **250**, **260** may be implemented in software, hardware or a combination of software and hardware. Each module **240**, **250**, **260** is operable to process data packets received from the physical layer of respective communication interface **210**, **220**, **230** and to prepare data packets for transmission through the physical layer of respective communication interface **210**, **220**, **230**.

[0043] A central communications module **145** on payload **140** may communicate with each of communication interface modules **240**, **250**, **260** to process data packets received from one or more of communication interface modules **240**, **250**, **260**. The central communications module **145** can, upon instruction from processor **147**, prepare one or more data packets for transmission through one or more of communication interface modules **240**, **250**, **260**.

[0044] A Global Positioning System (GPS) module **149** within payload **140** is operable to communicate, through a dedicated communication interface **230**, a GPS unit or subsystem within UV or UAV **125**. In some embodiments, the communication interface **230** may be a serial connection that transmits data packets. The serial connection **230** may be used to send high-speed data in one-direction from the GPS unit on UV or UAV **125** to payload **140**.

[0045] In some embodiments, payload **140** may have a small micro controller functioning as a gas sensor, and may need to correlate detected sensor data with a geographical location. As payload **140** maybe a low-powered device, it may not have a GPS

module on board. Instead, payload **140** may obtain GPS data from a GPS module on UV or UAV **125** through a suitable interface such as serial connection **230**. This solution removes the complexities associated with integrating a GPS module within a payload, or with power consumption of a GPS module on a payload, generally lowering the cost of a payload. The serial connection **230** from UV or UAV **125** to payload **140** can be a suitable mechanism for streaming one-way data.

[0046] UV or UAV **125** may include a processor or controller **155**. Processor or controller **155** transmits control commands to other components within UV or UAV **125** to control operation of the UV or UAV **125**. In some embodiments, processor **155** may also transmit control commands via one or more interfaces **210, 220, 230** to payload **140** for controlling operations of payload **140**.

[0047] UV or UAV **125** may include a communication module for each of communication interface **210, 220, 230**. For example, UV or UAV **125** may include an Ethernet interface communication module **270**, a CAN Bus interface communication module **280** and a serial interface communication module **290**. Each of the communication interface modules **270, 280, 290** may be implemented in software, hardware or a combination of software and hardware. Each module **270, 280, 290** is operable to process data packets received from the physical layer of respective communication interface **210, 220, 230** and to prepare data packets for transmission through the physical layer of respective communication interface **210, 220, 230**.

[0048] In some embodiments, UV or UAV **125** is controlled by a remote station, such as a ground station **160** or a client device **105**. UV or UAV **125** may also be configured for autonomous control without use of ground station **160**. UV or UAV **125** is configured to generate vehicle status data from sensor subsystem **150**, and to transmit the vehicle status data to the client device **105** or ground station **160**. The vehicle status data may be transmitted to the control station client device **105** or ground station **160** in real-time, or near real-time. The vehicle status data may include vehicle location data from sensors **150**, images, videos or other types of data from payload **140**, and so on. The vehicle status data may include navigation and other measurement data from navigation control **135**, as well as operating parameters from processor **155** and travel (e.g., flight) control data from travel/flight control **130**. The vehicle status data may include communication status data from communication module **190**. The vehicle status data may also include payload status data from payload control module **185**.

[0049] In some embodiments, payload **140** is controlled by a remote station, such as a ground station **160** or a client device **105**. The control signals may be transmitted by the

remote station to UV or UAV **125** first, which can then process and transmit control signals to payload **140**.

[0050] A central communications module **190** on UV or UAV **125** may communicate with each of communication interface modules **270**, **280**, **290** as well as external RF interface **193** to process data packets received from the various communication interfaces. The central communications module **190** can, upon instruction from processor **155**, prepare one or more data packets for transmission through one or more of communication interface modules **270**, **280**, **290**, or external RF interface **193**.

[0051] An external RF interface **193** on UV or UAV **125** may be configured to communicate with an external RF interface **173** on ground station **160**. The RF interface **193** may include a radio transceiver (e.g., e.g., a radio transmitter and a radio receiver). The radio transceiver may be operable to send and receive radio signals in specific radio frequency bands, the radio signals modulated to carry one or more data packets from ground station **160** or client device **105**. For example, a radio frequency band of the radio transceiver may be 2.4G Hertz (Hz). Lower frequencies, such as 433 mega-Hertz (MHz) and 900 MHz, may be chosen for longer ranges.

[0052] In some embodiments, the frequencies chosen for an RF interface **173**, **193** depend on a number of factors, which may include anticipated terrain (e.g., lower frequencies can transmit further or penetrate further into buildings or tree canopy), compliance with local regulations regarding spectrum use, possible interference with known users of spectrum, possible interference from known or anticipated sources of electromagnetic interference (EMI), ease of component availability or system manufacturability, and so on. Commonly used bands for North American civilian UVs or UAVs may be in the 2.4 giga-Hertz (GHz) uncontrolled spectrum; elsewhere, 900 MHz or other frequencies may also be employed.

[0053] In some embodiments, external RF interface **193** may include a Wi-Fi interface, such that UV or UAV **125** may communicate with ground station through Wi-Fi protocol.

[0054] Referring now to **FIG. 4**, which shows a schematic diagram of an example ground station **160**. Ground station **160** may include a sensor subsystem **165** (which may include a global positioning system (GPS) subsystem), a communications module **170** configured to process received data packets, and to prepare data packets for transmission through external RF interface **173**, an external RF interface **173** configured to communicate with external RF interface **193** on UV or UAV **125**, a processor or controller **175**, a payload control module **186**, and a UV or UAV control module **188**. The sensor subsystem **165** may

be used to acquire environmental data if the ground station **160** is proximate or near the UV or UAV **125**, where the environmental data may be used for controlling the UV or UAV **125**, the payload **140**, or the loaded vehicle **200**, such as location data, weather data, and so on. Payload control module **186** may generate command signals for controlling payload **140**, and UV or UAV control module **188** may generate command signals for controlling UV or UAV **125**. Both types of control commands may be processed by communications module **170** and transmitted to UV or UAV **125** and payload **140** via external RF interface **173**.

[0055] As shown in FIG. 5A, the client device **105** may comprise a communications subsystem **110**, a processor or central computer system **115** and a display **120**. The communications subsystem **110** allows for seamless communications between the client device **105** and UV or UAV **125**, and seamless communications between the client device **105** and payload **140**, and between the client device **105** and each ground station **160**, when ground stations **160** are used. The User Interface (UI) **180** is generated by processor **115** for display on the display **120** of a client device **105**, which remotely controls the UV or UAV **125**, the payload **140**, and/or the loaded vehicle **200** or as part of a control system for one or more vehicles. Display **120** may be a touch-screen display, but a non-touch display may be used. In some embodiments, client device **105** may be on a single-unit computer (i.e., one with a built-in display), but a multi-unit computer (i.e., with a separate display) may be used instead. Payload control module **195** may generate command signals for controlling payload **140**, and UV or UAV control module **198** may generate command signals for controlling UV or UAV **125**. Both types of control commands may be processed by communications module **110** and transmitted to UV or UAV **125** and payload **140** via ground station **160**.

[0056] The client device **105** is configured to display at least a subset of the received vehicle status data for each UV or UAV **125** or payload **140** in an interface (such as User Interface (UI) **180**, for example). A display **120** may provide a graphical representation of the respective vehicle location data of each of the vehicles **125**. Through the interface, the client device **105** may receive control command input. The control command input is associated with one of the UV or UAV **125** having its vehicle status data displayed in the interface. The client device **105** may then transmit the received control command, or a command derived therefrom, to the UV or UAV **125**. The interface may enable a user to view status and control operation of each of one or more UV or UAVs **125** such that the location of each UAV is shown in the interface, and each UV or UAV **125** may be independently controlled through the interface by selecting a particular one of the UV or UAV **125** to control. In this way, multiple UV or UAV **125** may be monitored and controlled through an interface at the client device **105**.

[0057] Further detail on the controlling UVs or UAVs **125** using interface **180** is provided in PCT Application No. PCT/CA2013/000442 entitled "System and Method for Controlling Unmanned Aerial Vehicles", the entire contents of which is hereby incorporated by reference. Client device or control station **105** may control interface panels to display a location of the UV or UAV **125**.

[0058] **FIG. 5B** shows a block diagram illustrating hardware components of an example client device **105** according to some embodiments. A processor or controller **115** can execute instructions in memory **2600** to configure communications module **110**, payload control module **195** and UV or UAV control module **198**. A processor **115** can be, for example, any type of general-purpose microprocessor or microcontroller, a digital signal processing (DSP) processor, an integrated circuit, a field programmable gate array (FPGA), a reconfigurable processor, or any combination thereof.

[0059] Memory **2600** may include a suitable combination of any type of computer memory that is located either internally or externally such as, for example, random-access memory (RAM), read-only memory (ROM), compact disc read-only memory (CDROM), electro-optical memory, magneto-optical memory, erasable programmable read-only memory (EPROM), and electrically-erasable programmable read-only memory (EEPROM), Ferroelectric RAM (FRAM) or the like. Storage devices **2400** include memory **2600**, databases **2025**, and persistent storage **2420**.

[0060] Each I/O unit **2100** enables client device **105** to interconnect with one or more input devices, such as a keyboard, mouse, camera, touch screen and a microphone, or with one or more output devices such as a display screen **120** and a speaker.

[0061] Each communication interface **2300** enables client device **105** to communicate with other components, to exchange data with other components, to access and connect to network resources, to serve applications, and perform other computing applications by connecting to a network (or multiple networks) capable of carrying data including the Internet, Ethernet, plain old telephone service (POTS) line, public switch telephone network (PSTN), integrated services digital network (ISDN), digital subscriber line (DSL), coaxial cable, fiber optics, satellite, mobile, wireless (e.g., Wi-Fi, WiMAX), SS7 signaling network, fixed line, local area network, wide area network, and others, including any combination of these. For example communication interface **2300** may include an Ethernet connection to ground station **160**, or a wireless communication interface operable to communicate with ground station **160**. In some embodiments, communication interface **2300** may include a RF interface operable to communicate with UV or UAV **125**.

[0062] Referring back to **FIG. 3**, sensors **150** on UV or UAV **125** may include different types of sensors, and may provide navigational instruments, travel instruments and flight instruments. An example sensor **150** is a magnetic sensor or magnetic field sensor, such as a magnetometer, which is used to measure the magnetization of a magnetic material, magnetic field strength, changes to the magnetic field strength, and the direction of the magnetic field at the current location of UV or UAV **125**. A measurement unit may include an accelerometer and magnetometer to compute heading, elevation or bank angle of the UV or UAV **125**. Other example sensors **150** include navigation instruments such as a gyroscope (e.g., device for measuring and maintaining orientation, measuring rotational velocity, and so on) and a magnetic compass. Sensors **150** may also include position instruments such as an accelerometer (e.g., device that measures proper acceleration or linear acceleration or g-force) and a GPS. The position instruments may be used to stabilize position of the UV or UAV **125** and may include instruments for angle, displacement, distance, speed, and acceleration. Sensors **150** may also include acoustic, sound and vibration instruments, transportation instruments (e.g., speedometer), chemical instruments, electrical instruments, magnetic instruments, and radio instruments, environmental, weather or moisture instruments, fluid flow instruments, radiation instruments, optical or light sensors, pressure instruments, force or density instruments, thermal instruments (e.g., thermocouple, thermometer), proximity instruments, and so on. Sonar range finders, laser range finders, and cameras are other example sensors **150**. Measurement data or calibration parameters may also include rotational velocity, linear acceleration, magnetic field strength, and other data obtained or calculated from sensor subsystem **150**.

[0063] UV or UAV **125** may be associated with a vehicle data set (e.g., data collected or computed for a specific UV or UAV **125**) that may be updated in real-time or near-real-time. The data set for each UV or UAV **125** may be stored and updated at a remote data storage device of ground station **160** or client device **105**, or a subset thereof may be stored and maintained at a local data storage device of UV or UAV **125**.

[0064] The vehicle data set may be gathered by the UV or UAV **125** sensor subsystem **150** and transmitted to the ground station **160** by the UV or UAV **125** communications module **190** via RF interface **193**.

[0065] UV or UAV **125** may implement different travel (e.g., flying) modes and travel (e.g., flight) plans, including manual travel (e.g., flying) mode and waypoint travel (e.g., flying) mode. A travel (e.g., flight) plan may be relative to other objects, such as another vehicle or ground station **160**, or may be absolute defined by navigational data. A waypoint is a user-specified position, represented by coordinates on a map to provide a waypoint indication. It is a navigable marker, meaning that a UV or UAV **125** may be directed to go to

that position. There may be attributes associated with the waypoint, such as specific actions that a UV or UAV **125** must take upon reaching the waypoint (e.g., take photos, send back photos, deliver a payload, aim a payload, trigger a payload to sample, land, move to a specific height, pause before continuing on the waypoint route, raise an alert at the control station **105**, or some other set of actions), a minimum or maximum altitude which the UV or UAV **125** must not exceed while within a specified proximity to the waypoint, a maximum velocity which the UV or UAV **125** must not exceed when within a specified proximity to the waypoint, or some other attribute.

[0066] A travel (e.g., flight) plan may consist of multiple waypoint routes, with each waypoint route associated with one or more UV or UAV **125**. A travel (e.g., flight) plan may consider different special areas, including a no-fly zone, points of interest, targets, perimeters, and so on.

[0067] A no-fly (or no entry) zone is conceptually a boundary through which a UV or UAV **125** may not pass, such that a UV or UAV **125** may not be located within the no-fly (or no entry) zone. A no-fly (or no entry) zone may be a closed boundary, ordered series of points, and the lines connecting these points, a regular shape, such as a circle or oval, with specified defining characteristics (e.g., for a circle, center point and radius).

[0068] A point of interest ("POI") is a navigable marker (that is, a marker to which the vehicle may be navigated), unless it is located within a no-fly (or no entry) zone. A POI may also be used as a target for camera viewing (e.g., for payload **140**), sensor readings, or as an objective point for another on-vehicle payload.

[0069] A target is a non-navigable marker (that is, a marker to which a vehicle may not be navigated). A target is often used to indicate an objective point for camera viewing (e.g., for payload **140**), sensor readings, or some other on-vehicle payload. A target may be contained within a no-fly (or no entry) zone.

[0070] A perimeter is conceptually a shape through whose boundary a vehicle may not pass, such that a vehicle must be located within the perimeter. A perimeter may be a closed shape, ordered series of points, and the lines connecting these points, or a regular shape, such as a circle or oval, with specified defining characteristics (e.g., for a circle, center point and radius).

[0071] In order for UV or UAV **125** to implement different travel (e.g., flying) modes and travel (e.g., flight) plans accurately, sensors **150** (e.g., magnetic sensors) and other navigation instruments and travel (e.g., flight) instruments with magnetized or magnetic components should be properly calibrated to ensure proper operation of the UV or UAV **125**.

[0072] A payload **140** is often used to deliver parcels, record photographs or videos from the perspective of the UV (e.g., an aerial perspective of a UAV), or to capture and transmit environmental data in regions that are difficult or dangerous to access by human. In almost all the scenarios, it is desirable for a remote station, such as a ground station **160** or a client device **105** to communicate with, and often control, the payload **140** as well as the UV or UAV **125** remotely. A user may be associated with the ground station **160** or client device **105**. For example, a user may monitor a flight, navigation or movement path of the UV or UAV, which may also be a travel (e.g., flight) path of the payload, and receive, in real-time or near real-time, one or more photographs from the payload (e.g., a camera) taken along the travel (e.g., flight) path. The user may wish to explore an area identified in the photograph in greater detail, and may thus send command signals to the payload **140** to zoom in a particular direction, as well as send command signals to the UV or UAV **125** to travel or fly a bit closer to the area, or stay stationary while the payload zooms in and takes additional photographs.

[0073] Referring now to **FIG. 8**, which illustrates a communication system **30** including a client device **105**, a ground station **160**, and a loaded vehicle **200**. In some embodiments, a client device **105** is configured to receive and transmit electronic signals representative of one or more data packets **300** from/ to a ground station **160**. A ground station **160** is configured to receive and transmit electronic signals representative of one or more data packets **400** from/ to UV or UAV **125**. A UV or UAV **125** is configured to receive and transmit electronic signals representative of one or more data packets **500, 800, 900** from/ to payload **140**. Even though only one client device is illustrated, there can be multiple client devices. Similarly, there can be multiple ground stations and multiple UVs or UAVs and payloads.

[0074] Client device **105** and ground station **160** may be connected through a suitable communication network or interface **310**. For example, client device **105** and ground station **160** may be a wired connection or connected wirelessly. For example, client device **105** and ground station **160** may be connected wirelessly via wireless local area network (WLAN) **310**. In some embodiments, within the communication network **310**, client device **105** may be associated with an Internet protocol (IP) address **80**, for instance, 100.100.1.1. Ground station **160** may be associated with an IP address **81**, for instance, 100.100.1.2. IP addresses **80, 81** may be assigned statically or allocated by a Dynamic Host Configuration Protocol (DHCP) system. Of the four octets of the 32-bit IP addresses **80, 81**, the first three are identical. That is, based on the IP addresses, it can be determined that the two devices **105, 160** are likely on the same subnet. Data packets **300** may be transmitted bi-directionally via communication network **310**.

[0075] Ground station **160** and UV or UAV **125** may be connected through a suitable wireless communication network or interface. For example, ground station **160** and UV or UAV **125** may be connected through a radio-based network **410**, e.g., a radio frequency communication channel. Range, signal strength, type of antenna, and additional attributes of the radio system may vary. In some embodiments, ground station **160** may be associated with an IP address **83**, for instance, 192.168.100.1. UV or UAV **125** may be associated with an IP address **85**, for instance, 192.168.100.2. The IP addresses **83**, **85** may be statically or dynamically assigned within the radio network **410**. Data packets **400** may be transmitted bi-directionally via radio network **410**.

[0076] Payload **140** and UV or UAV **125** may be connected through one or more suitable communication networks or interfaces. For example, as described herein, payload **140** and UV or UAV **125** may be connected through an Ethernet interface **210**, a CanBus interface **220**, and optionally a serial connection **230**. In some embodiments, UV or UAV **125** may be associated with an IP address **86**, for instance, 192.168.200.2. Payload **140** may be associated with an IP address **87**, for instance, 192.168.200.2. IP addresses **86**, **87** may be assigned statically or allocated by a Dynamic Host Configuration Protocol (DHCP) system. Of the four octets of the 32-bit IP addresses **86**, **87**, the first three are identical. That is, based on the IP addresses, it can be determined that the two devices **125**, **140** are likely on the same subnet.

[0077] Ethernet interface **210** may be configured to transmit, in a single direction or bi-directionally, data packets **500** that require relatively high-speed transmission. For example, Ethernet interface **210** may be configured to transmit high-quality image or video data from payload **140** to ground station **160** or client device **105**. In some embodiments, the data packets **500** may tolerate some loss during transmission from ground station **160** to payload **140**. For instance, an image (e.g., a Joint Photographic Experts Group (JPEG) file) stored on payload **140** may be approximately 1 megabytes (MB) in size, which is transmitted in approximately, for example, 2000 data packets **500**. Out of the 2000 data packets, 5% or 100 data packets may be lost or corrupted during transmission, and the image can still be reconstructed by ground station **160** or client device **105** using the rest of data packets **500**, without affecting the overall quality of the reconstructed image. In some embodiments, Ethernet interface **210** may be used to transmit non-critical data that can tolerate minimal or some data loss during transmission.

[0078] In some embodiments, a payload development kit ("PDK") may be provided. The PDK may include a software package that allows third party users to develop and deploy applications that can extend the aircraft functionality of UV or UAV **125** to a graphical user interface (GUI) on ground station **160** or client device **105** (or both), and in turn allow

the ground station **160** or client device **105** to control certain subsystems (e.g., flight, camera, navigational flight plans) of UV or UAV **125** and/or payload **140**. To this end, the third party user, through the ground station **160** or client device **105**, would need to receive various state data about UV or UAV **125** and/or payload **140**. The state data may be produced by subsystems on the UV or UAV and the payload, and available to ground station or client device for consumption and use, through the PDK interface, as if the ground station or client device is communicating directly with the payload **140**. For example, payload **140** can communicate to the UV or UAV **125** over the Ethernet interface **210**, and the UV or UAV **125** can route the communication to ground station **160** in real time or near real time.

[0079] CanBus interface **220** may be configured to transmit data packets **800** that require lossless, or nearly lossless transmission, such as command signals. CanBus interface **220** may in some embodiments transmit data packets at a slower speed than Ethernet interface **210** does; at the same time, CanBus interface **220** can be a more reliable communication link than an Ethernet connection, and as a result, can be more suitable for delivery of critical data packets such as various command signals. For example, CanBus interface **220** may be used to transmit one or more command signals such as: travel (e.g., flight) control commands (e.g., requested heading, altitude, orientation, all motors off), navigation commands (e.g., travel (e.g., fly) home, stop and hover), communications link commands (e.g., change encryption parameters, change radio channel), camera commands (e.g., change camera heading, zoom in or out, enable/disable video, take still image) or other commands (e.g., turn lights on/off). The data packets **800** may be transmitted in a single direction, or bi-directionally. In some embodiments, the transmission rate of a CanBus interface **220** may range from 40 kilobits (Kbits) to 1 Mbits per second.

[0080] In some embodiments, data packets designated for CanBus interface **220** may be encapsulated within a HyperText Transfer Protocol (HTTP) request by client device **105**. One or more client devices **105** can send CanBus requests encapsulated within one or more HTTP requests to payload **140** through the UV or UAV **125**. These requests travel over the radio network **410** to UV or UAV **125**, and are then de-encapsulated and transmitted through CanBus interface **220** to payload **140**. In some embodiments, payload **140** may also update variables on the UV or UAV **125**, and the updated variables may be read by the ground station **160** or client device **105** through the same HTTP interface. As further described below in reference to FIGs. **6** and **7**, the HTTP requests may include one or more data frames, each data frame including a data packet.

[0081] A third communication interface **230** (which is optional) may be a serial connection interface **230** configured to transmit data packets **900**, in a single direction, or bi-directionally. For instance, serial connection **230** may be used to transmit data packets **900**

from a GPS system on UV or UAV **125** to payload **140**, to help facilitate zooming in/out or capturing data by payload **140**.

[0082] In some embodiments, CanBus interface **220** may be used by payload **140** to inform the GPS system on UV or UAV **125** types of data the payload requires, and the GPS system may transmit the requested data to the payload over the serial connection **230**. The GPS system may only need to be told once what data to send, and send the requested data continuously or whenever an updated is available. This requested data may include location information, altitude, precise time, and other types of data. The use of a serial connection **230** between the GPS system on UV or UAV **125** and payload **140** means that the UV or UAV does not need to separately retrieve, process and route the data from the GPS system to payload.

[0083] In some embodiments, the CanBus **220** and/or the serial connection **230** may provide other data from UV or UAV **125** to payload **140**, such as attitude/heading (useful for pointing cameras), battery state, distance and direction to the ground station (useful for command relay), and mission objectives.

[0084] On UV or UAV **125**, each of the communication interfaces **210**, **220**, **230** may be assigned a sub-address defined within the Internet Protocol, such as a port number **92**, **94**, **96**. On payload **140**, each of the communication interfaces **210**, **220**, **230** may be assigned a port number **91**, **93**, **95**. Based on the port number, a data packet **400** arriving at UV or UAV **125** may be processed and re-routed to payload **140** via one of the communication interfaces **210**, **220**, **230**. Similarly, based on the port number, a data packet at payload **140** may be transmitted to UV or UAV **125** via one of the communication interfaces **210**, **220**, **230**. The port numbers may be statically or dynamically assigned.

[0085] Any of the communication channels or links **310**, **410**, **210**, **220**, **230** may be encrypted for secure communication. For example, HTTPS technology may be used to facilitate transmission of data on communication link **310**. For another example, certain signal modulation may be applied to transmission of data using radio communication link **410**. Other encryption methods may be used as well, such as public/ private key scheme, secure hash algorithms such as SHA56 encryption algorithm, and verification of a message authentication code or a digital signature.

[0086] At an initial set-up or configuration stage, which in some embodiments may be automatically executed as soon as the payload **140** is physically connected to UV or UAV **125**, IP addresses and appropriate port numbers may be assigned for each communication interface between payload **140** and UV or UAV **125**. The communication interfaces **210**, **220**, **230** may share the same IP address on each system (e.g., payload **140** or UV or UAV **125**),

or be assigned different IP addresses. Port numbers for communication interfaces **210**, **220**, **230** are different on each system. The port numbers may be randomly assigned within a certain range. For example, the port numbers **91** to **96** may be selected from a range between 49152-65535, which are known to be dynamic or private ports within TCP/IP. In some embodiments, a user may manually configure or customize the initial set-up or configuration of the port number or IP address of payload **140** or UV or UAV **125**.

[0087] During the initial set-up or configuration stage, payload **140** and UV or UAV **125** may automatically negotiate a set of interfacing rules, including, without limitation, at least one of:

- which communication interface(s) are available for use;
- which protocol(s) to use on each communication interface;
- the network address of the payload;
- the network (IP) ports on which the payload will send or receive data;
- a power-consumption profile for the payload;
- any other UV or UAV configuration parameters that the payload needs for its operation;
- any other payload configuration parameters that the UV or UAV or ground control system needs for operating the payload or the loaded vehicle.

[0088] **FIG. 7** is a flow chart illustrating an example process **700** of processing input, by a remote station, for transmission to a payload device **140**, according to some embodiments. The remote station (e.g., ground station **160**) may include a processor **155**, a communication interface **193** for communicating with one or more UV or UAVs **125**; and a non-transitory memory device storing a communications module **190**, the communications module comprising machine-readable instructions that, when executed by the processor, causes the processor to receive or retrieve an input at step **702**. The input may be received from an input/output (I/O) interface on remote station **160**, for example as an user input. The input may also be received from a client device **105** through connection interface **310**, such as data packets **300**. In some embodiments, the input may be retrieved from a memory device or from a cloud network. In some embodiments, the input may be determined by an intelligent, non-human agent such as an artificial intelligence agent using machine learning technologies.

[0089] In some embodiments, the remote station may be the client device **105**, with or without a ground station **160**. That is, the process described herein with reference to **FIG.**

7 may be executed by a ground station **160** or a client device **105**, or both (e.g., steps **702** and **704** may be performed by client device **105**, and step **706** may be performed by ground station **160**).

[0090] At step **704**, remote station **160** can process the input into one or more data packets **400** for transmission to a payload device through the UV or UAV when the input is for the payload device **140** connected to the UV or UAV **125**.

[0091] In some embodiments, the input can be processed into one or more data packets **400** by encapsulating some or all of the input within the one or more data packet **400**. Each data packet **400** may include a (data) payload and a header. For example, data packets **400** may be assembled or constructed based on a known protocol, such as an Transmission Control Protocol / Internet Protocol (TCP/IP) protocol. **FIG. 9** shows an example data packet **400** including: a header portion **405** and a payload or message portion **403**. The header portion **405** may include an IP address field **401** and a port number field **402**. The IP address field **401** may include a destination IP address and optionally a source IP address. The destination IP address may be, for example, the IP address of UV or UAV **125** if the data packet **400** is sent from remote station to UV or UAV **125**. In some embodiment, the destination IP address may be the IP address of payload **140**, for example, in cases where data packets are sent directly to the payload **140**, bypassing UV or UAV **125**. The port number field **402** may include a destination port number and optionally a source port number. There may be one or more additional fields (not illustrated) such as MAC address, Ethernet header, protocol type, message type (e.g., control command or otherwise), checksum. Even though IP protocol is used as an example, other appropriate communication standards or protocol may be used.

[0092] Referring back to **FIG. 7**, at step **706**, remote station **160** can transmit the one or more data packets **400** to the UV or UAV **125** through the communication interface **193** for delivery to the payload device **140**, where the payload **140** is connected to the UV or UAV **125** through at least two communication interfaces **210**, **220**, the two communication interfaces being of different types from each other.

[0093] Remote station may process the input for transmission into data packets **400** based on a type of the input. For example, if the input is a control command for the payload **140**, the remote station may process the input into data packet for transmission to the payload device through communication interface **210**; and if the input is determined to be data other than control commands (e.g., general status request) for the payload **140**, the remote station may process the input into data packet for transmission to the payload through communication interface **220**.

[0094] An example input that is not control command can be a travel (e.g., flight) plan. For example, depending on the functionality of payload **140**, a travel (e.g., flight) plan may need to be uploaded to the payload **140** before or during travel (e.g., flight). The travel (e.g., flight) plan maybe referenced by payload **140** during flight execution and if appropriate, modified by payload **140** autonomously. In this case, the remote station may process the travel (e.g., flight) plan into data packet for transmission to the payload through communication interface **220**, since travel (e.g., flight) plan is not considered to be a control command.

[0095] **FIG. 6** is a flow chart illustrating an example process **600** of communicating with a payload **140** through an UV or UAV **125** according to some embodiments. UV or UAV **125** may include a first and a second communication interface **210**, **220** for connecting to and/or communicating with a payload **140**, and a third communication interface **193** for communicating with a remote station via radio network **410**, the first and second communication interfaces being of different types from each other.

[0096] At step **602**, UV or UAV **125** may receive, through the third communication interface **193**, one or more data packets **400** from the remote station **160** or **105**.

[0097] At step **604**, UV or UAV **125** may transmit the one or more data packets to the payload **140** through the first communication interface **210** when the one or more data packets **400** are designated for the first communication interface.

[0098] At step **606**, UV or UAV **125** may transmitting the one or more data packets to the payload **140** through the second communication interface **220** when the one or more data packets **400** are designated for the second communication interface.

[0099] In some embodiments, UV or UAV **125** may determine that one of the one or more data packets is designated for the first **210** or second communication interface **220** based on a header **405** of the one data packet **400**.

[0100] In some embodiments, UV or UAV **125** may determine that one of the one or more data packets is designated for the first **210** or second communication interface **220** based on an IP address **401** of the one data packet **400**.

[0101] In some embodiments, the first and second communication interfaces comprise logical interfaces implemented through at least one hardware interface.

[0102] In some example embodiments, a data packet **400** prepared or assembled by remote station may include information representing if the data packet is designated for payload **140**. For example, data packet **400** may, in addition to carrying the data payload in a data field **403**, include information representing an IP address of payload **140** in an IP

address field **401** as part of a header **405**. For another example, data packet may include information representing an IP address of UV or UAV **125** in an IP address field **401** as part of a header **405**, and include additional information in header **405** indicating that the data packet is designated for payload **140** connected to UV or UAV **125**, so that UV or UAV **125** may process and transmit the data packet to payload **140** upon receipt of data packet **400**. For example, data packet **400** may include, in a port number field **402** as part of a header **405**, information representing a port number corresponding to a port number **91, 93, 95** assigned to a communication interface **210, 220, 230**. That is, a data packet **400** prepared by remote station **160, 105** for transmission to UV or UAV **125** or payload **140** can include, in a header portion **405**, information representative of the destination (e.g., UV or UAV **125** or payload **140**) and a communication interface (e.g., **210**) selected for routing the data packet to the destination. Where there is only one communication interface, the port number field **402** may be set to a default number or left empty.

[0103] Remote station may select an appropriate communication interface for routing data packet **400** based on a type of the input received and used to prepare the data packet. For an input that contains an image, if communication interface **210** is faster and more appropriate for transmitting high- quality data, remote station may select communication interface **210** for transmitting data packet **400** to payload **140**, and prepare the data packet accordingly, so that once UV or UAV **125** has received the data packet, it may process and route the data packet through interface **210** to payload **140**. For an input that contains a control command, if communication interface **220** is more reliable and more appropriate for transmitting critical data such as control commands, remote station may select communication interface **220** for transmitting data packet **400** to payload **140**, and prepare the data packet accordingly, so that once UV or UAV **125** has received the data packet, it may process and route the data packet through interface **220** to payload **140**.

[0104] In some embodiments, a port number in data packet **400** may represent both a destination (e.g., payload **140**) and a communication interface (e.g., interface **210**). For example, data packet **400** may include a destination IP address for UV or UAV **125**, which is the system connected to remote station via radio network **410**. In this instance, data packet **400** will be sent to UV or UAV **125** first before reaching payload **140**. The data packet may further include a port number **91** corresponding to communication interface **210**, which indicates to UV or UAV **125** that the data payload **403** carried in data packet **400** is intended for payload **140** and should be transmitted to the payload via communication interface **210**.

[0105] If data packet **400** includes, in port number field **402**, one from a plurality of port numbers **91 to 96**, UV or UAV **125** may process and interpret the specific port number to determine a final destination for the data packet. If the port number is, for example, **50000**

corresponding to an interface on UV or UAV **125**, then the communication module on UV or UAV **125** can determine that data packet **400** is intended for itself, instead of payload **140**.

[0106] UV or UAV **125** may store, on local memory, a reference table mapping each port number to a corresponding destination device and/or a corresponding communication interface.

[0107] In some embodiments, UV or UAV **125** may determine that data packet **400** is designated for the first **210** or second communication interface **220** based on a subnet of the destination IP address of the data packet. For example, if IP address **85** of UV or UAV **125** is 192.168.200.1 and IP address **87** of payload **140** is 192.168.200.2, and the destination IP address contained in an IP address field **401** in the header portion **405** is 192.168.200.1 /26, the presence of "/26" may be mapped to one of communication interfaces **210**, **220**, **230** of payload **140**. That is, when UV or UAV **125** receives data packet **400**, it can parse the data packet and read the information contained within the header, and based on "/26" within the destination IP address, determine that the data packet is meant or designated for payload **140** via communication interface **210**. When the destination IP address contained in an IP address field **401** in the header portion **405** is 192.168.200.1 /27, UV or UAV **125** can parse the data packet and read the information contained within the header, and based on "/27" within the destination IP address, determine that the data packet is meant or designated for payload **140** via communication interface **220**. When the destination IP address contained in an IP address field **401** in the header portion **405** is 192.168.200.1 /28, UV or UAV **125** can parse the data packet and read the information contained within the header, and based on "/28" within the destination IP address, determine that the data packet is meant or designated for payload **140** via communication interface **230**. Even though example IP addresses described herein are in IPv4 format, IPv6 may also be used in place of IPv4.

[0108] In some embodiments, the payload addressing may be static as the network packets are forwarded depending on configured ports from externally facing Wi-Fi interface on the UV or UAV to the payload's static IP address corresponding to a specific port.

[0109] In some embodiments, a NAT (Network Address Translation) system may be used to map the payload **140** directly into the subnet of the client device(s) **105**. That is, to a client device **105**, the payload **140** may appear to be on its local network, so IP packets can be sent and received by the client devices **105** to/ from payload **140** as if they were on the same network.

[0110] In some embodiments, ground station **160**, client device **105**, and UV or UAV **125** are all on the same network. When payload **140** attaches to UV or UAV **125**, the payload may be configured to connect to the UV or UAV on one or more connection

interfaces (e.g., Ethernet **210** or CanBus **220**). For example, as described herein, one or more specific ports can be configured to forward packets from the UV or UAV's external interface (e.g., a radio or Wi-Fi interface) to the Ethernet interface **210** that the payload is connect to. An IP address may be dedicated to the payload on the Ethernet interface **210**. From ground station's perspective, UV or UAV **125** may act as the point of contact for payload **140**. Ground station **160** or client device **105** therefore does not address the payload directly when transmitting data. For example, upon connecting to UV or UAV **125**, payload **140** may request for port 4001 to be opened for forwarding between the UAV's external interface **193** and the Ethernet interface **210**. An IP address for payload **140** may be assigned for port 4001. The routing rules can then be automatically configured on UV or UAV **125**, which causes all packets for port 4001 to be forwarded to the payload's corresponding IP address on port 4001. The ground station may then attempt to send data packets to payload **140** by sending the data packets to port 4001 on the UV or UAV's IP address assigned to the UV or UAV's external interface **193**, which may be radio or Wi-Fi.

[0111] In some embodiments, UV or UAV **125** may be configured to monitor a quality of service (QoS) score of a first communication channel associated with the first second communication interface **210**, and upon detecting that the QoS score is below a pre-determined threshold, UAV **125** may be transmit the one or more data packets to the payload device through the second communication interface **220** when the one or more data packets are designated for the first communication interface **210**. Similarly, UV or UAV **125** may be configured to monitor a quality of service (QoS) score of a second communication channel associated with the second second communication interface **220**, and upon detecting that the QoS score is below a pre-determined threshold, UV or UAV **125** may be transmit the one or more data packets to the payload device through the first communication interface **210** when the one or more data packets are designated for the second communication interface **220**.

[0112] The QoS score may indicate, in some cases, that the associated communication channel may have a network or connection failure (e.g., QoS score being much lower than the pre-determined threshold), or may be close to a network or connection failure (e.g., QoS score being below but close to the pre-determined threshold). In these scenarios, UV or UAV **125** may pre-emptively, or concurrently with detection of the network failure, route all traffic to payload **140** through the communication channel that is not detected to have any network or connection issues. For instance, if communication interface **210** somehow fails, data packets meant for payload may be transmitted via communication interface **220** or **230**, even if the data packets are previously determined to be designated for communication interface **210**.

[0113] In some embodiments, a traffic management mechanism may be applied to one or more of communication links **310**, **410**. For example, a QoS system may be used to prioritize control command signaling over other uses (e.g., payload data transmission that does not include any control command). Each type of data may be categorized based on priority and transmitted according to a pre-determined QoS protocol.

[0114] Both the pre-determined QoS threshold for detecting network issues and the QoS protocol for traffic management may be initialized automatically, or manually set by a user, at the initialization stage of payload **140** or UV or UAV **125**.

[0115] In some embodiments, UV or UAV **125** may transmit data packets from the payload **140** to the remote station through the third communication interface **193** via radio network **410**.

Authentication

[0116] In some embodiments, one or more of payload **140**, UV or UAV **125**, client device **105** and ground station **160** may receive and authenticate an identity associated with a sender of the data packets **300**, **400** prior to transmitting any data packet to UV or UAV **125** or payload **140**. For example, the sender of an input which contains a control command for UV or UAV **125** or payload **140** may be client device **105**. Client device **105** may first authenticate a user (e.g., a human logged into the communication system via user interface **180**) as being someone who has a role or rank that has been pre-approved to access and control UV or UAV **125** and/or payload **140**.

[0117] In some embodiments, the client devices **105** may need to present credentials or permission to use from another (e.g., secondary) source, which the payload, UV or UAV or ground station may verify individually. Such credentials may be operator credentials, chain of command authorization for specific actions, and so on. For example, a certain payload may only be accessible for use to a pilot of a certain rank (or higher) who has not logged more than a certain amount of travel (e.g., flight) time in the last 24 hours, and some functions on the payload may then only be accessible if authorized by a second person with a specific rank. Such authorization requirements, on a function-by-function or port-by-port basis, may be set up by payload **140** or UV or UAV **125** at the time of initial configuration, and subsequently communicated to the ground station and/or client device.

[0118] In some embodiments, client device **105** itself may need to be authenticated by ground station **160**, UV or UAV **125** or payload **140** prior to sending any data packets **300** to ground station or payload. This may be accomplished through a private key system, a public key system, or any other authentication system. Such a system may be pre-built into

the communication system on the ground station or the UV or UAV, so that client devices do not need their own authentication system.

[0119] In some embodiments, UV or UAV **125** may be required to authenticate itself to the payload **140**. For example, only a UV or UAV in a specific fleet may connect to and use a specific payload. This may be accomplished by one or more appropriate authentication mechanism(s) at the stage of initial configuration of the payload. If the UV or UAV cannot be authenticated, some or all features on the payload may be disabled, or the payload may operate in a different manner (e.g., degraded as opposed to fully functional).

[0120] In some embodiments, payload **140** may be required to authenticate itself to UV or UAV **125**. For example, to only allow payloads which have gone through some certification process to be used with a particular UV or UAV. Various authentication methods may apply.

[0121] The software components of various devices **105**, **160**, **125**, **140** relating to the communication protocol, scheme and interfaces in the embodiments described herein may be implemented as part of Payload Development Kit (PDK).

[0122] The PDK is a software development kit which enables simple and rapid third-party integrations and payload developments. For example, the PDK allows all or a substantial amount of software development required for a payload to communicate seamlessly with the ground station or client device to be on the ground station, which communicates with the UV or UAV through a network. The PDK interface provides power and secure communication (e.g., encrypted communication channel) to the payload over TCP/IP, and from the ground station software developer's perspective, any data transmitted from and to the payload may be through the TCP/IP interface of the PDK, regardless of how the data actually travels to the payload. In addition, there is no need to develop software for the UV or UAV, as the payload communicates with a transparent interface directly to the software developed through the PDK on the ground station.

[0123] In some embodiments, the PDK may provide a flexible hardware, software and electrical interface for end-users and systems integrators to quickly develop tightly integrated payloads for a UV or UAV. In addition, a Software Development Kit (SDK) may be provided to interface with other control applications across a set of secure APIs.

[0124] In some embodiments, a payload development kit ("PDK") may be provided. The PDK may include a software package that allows third party users to develop and deploy applications that can extend the aircraft functionality of UV or UAV **125** to a graphical user interface (GUI) on ground station **160** or client device **105** (or both), and in turn allow the ground station **160** or client device **105** to control certain subsystems (e.g., travel (e.g.,

flight), camera, navigational flight plans) of UV or UAV **125** and/or payload **140**. To this end, the third party user, through the ground station **160** or client device **105**, would need to receive various state data about UV or UAV **125** and/or payload **140**. The state data may be produced by subsystems on the UV or UAV and the payload, and available to ground station or client device for consumption and use, through the PDK interface, as if the ground station or client device is communicating directly with the payload **140**. For example, payload **140** can communicate to the UV or UAV **125** over the Ethernet interface **210**, and the UV or UAV **125** can route the communication to ground station **160** in real time or near real time.

[0125] For instance, a user may wish to control a payload **140** that contains a gimbal (e.g., a pivoted support that allows the rotation of an object about an axis) when the payload **140** is in the air and connected to a UV or UAV **125**. In order to do so, the user can develop software for a remote station (e.g., a ground station or a client device) using the PDK. The PDK may allow the user to develop and deploy a software application which can communicate with the payload **140** through the UV or UAV **125** over the wireless link. Data packets may be sent and received by the remote station to/from the payload through the UV or UAV **125**. Once the data packets are received by the UV or UAV **125**, it will forward the packets through one or more appropriate interfaces **210**, **220** to the payload. The payload **140** may need to be kept up-to-date of information regarding the orientation and environment around it to perform its functionality more accurately. As such the payload **140** will require state data from UV or UAV **125** at a steady interval. This data may include data representing: GPS coordinates, aircraft heading, bearing or height above sea level, and so on. Together, with remote station **160** or **105** controlling the payload **140** and the UV or UAV **125** providing the means to communicate remotely as well as providing important state data to payload **140**, the payload can perform its functions as required by the user.

[0126] In some embodiments, the SDK may be stored on a non-transitory computer readable medium for developing software applications for controlling UV or UAV **125** and payload **140**. The SDK may include one or more application programming interfaces (APIs) for utilized in developing software applications at a remote station (e.g., ground station **160** or client device **105**). For example, in some embodiments, a first API can be configured to access the UV or UAV to obtain information regarding the payload; and a second API can be configured to access the payload to obtain information regarding the UV or UAV.

[0127] In some embodiments, the first API is configured to access the payload through a communication interface **210** or **220** between the remote station and the UAV.

[0128] In some embodiments, the second API can receive, at the remote station, one or more data packets designated for the payload device, transmit the one or more data

packets to the payload device through the first communication interface when the one or more data packets are designated for the first communication interface, and transmit the one or more data packets to the payload device through the second communication interface when the one or more data packets are designated for the second communication interface.

Secondary Device on Payload or UV or UAV

[0129] In some embodiments, client software may be installed at a client device **105** to facilitate communication with a secondary device connected to the payload **140** or UV or UAV **125**. The connection interface between the secondary device and the payload or the UV or UAV may be a serial, USB or network connection. A virtual driver subsystem, which may be packaged as part of the PDK, may be configured to enable the connection between the client device and the secondary device.

[0130] For example, if the secondary device is a USB device, a virtual device driver (for instance, a virtual USB driver on the client device which may have a Windows™ operating system (OS)) may process and package the data packets between the client device and the USB device, and encapsulate the data packets between the USB device and the client device for transmission on one or more of the available communication channels associated with connection interfaces from client device to the UV or UAV (which may include a ground station in-between), and from the UV or UAV to the payload. The UV or UAV or payload may contain a USB interface, to which the USB device may connect, as well as connection and processing circuitry to allow the USB signals to be de-encapsulated from the network communication channels **310**, **410**, **210**, **220**, **230** and transmitted directly via the USB interface to the USB device. Data flowing in the other direction would be similarly encapsulated by communication modules on the payload and the UV or UAV, transmitted to the client device, and de-encapsulated by the virtual driver on the client device, and relayed to the appropriate application on the client device.

[0131] In some embodiments, the secondary device may be connected directly to the UV or UAV via an appropriate connection interface (e.g., a USB interface), in which case the communication module on the UV or UAV may handle the encapsulation and de-encapsulation of the data packets between the client devices and the secondary device.

Control by Payload

[0132] In some embodiments, a payload **140** may issue or route one or more commands to UV or UAV **125**, through a communication interface such as CanBus **220**. This allows the payload to control the UV or UAV, which may be needed if the radio communication channel **410** between the UV or UAV and remote station fails or experiences issues. This may be referred to as “control by payload (CBP)”. CBP may be configured

automatically at system or payload start-up stage, along with the other configuration parameters. A specific set of commands may be available to payload **140** for use. Examples of commands available include travel (e.g., flight) control commands (e.g., requested heading, altitude, orientation, all motors off), navigation commands (e.g., travel (e.g., fly) home, stop and hover), communications link commands (e.g., change encryption parameters, change radio channel), camera commands (e.g., change camera heading, zoom in or out, enable/disable video, take still image) or other commands (e.g., turn lights on/off).

[0133] In some embodiments, payload **140** may contain an out-of-band wireless signaling system (such as a remote control system). In the event that the main radio communication link **410** between UV or UAV **125** and remote station is lost or otherwise unfit for data transmission, the direct wireless link between payload **140** and UV or UAV **125** can take over, or can provide emergency commands to the UV or UAV.

[0134] In some embodiments, a wireless link between payload **140** and UV or UAV **125** may be provided.

[0135] In some embodiments, a separate wireless communications channel or system may be used by the payload to communicate with a remote station. Such a system may use a different spectrum or even a different physical mechanism entirely (e.g., laser-based communication medium).

[0136] In some embodiments, UV or UAV may have multiple wireless communication systems operating simultaneously, or available to back up the main link. This would be transparent to the higher-level communications systems disclosed herein.

[0137] In accordance with one aspect, there is provided an unmanned vehicle (UV). The UV may comprise a UAV, UGV, unmanned aquatic vehicle, or any robotic structure (including a fixed structure). The UV comprises a processor configured to control operations of the UV, a first and a second communication interface for connecting to a payload device, the first and second communication interfaces being of different types from each other, a third communication interface for communicating with a remote station, and a non-transitory memory device storing machine-readable instructions that, when executed by the processor, causes the processor to: receive through the third communication interface one or more data packets from the remote station, transmit the one or more data packets to the payload device through the first communication interface when the one or more data packets are designated for the first communication interface, and transmit the one or more data packets to the payload device through the second communication interface when the one or more data packets are designated for the second communication interface.

[0138] In accordance with another aspect, the first or second communication interface may include one of: Ethernet connection, Controller Area Network (CAN) Bus connection, serial connection, Inter-integrated Circuit (I2C) connection, printed circuit board (PCB) interface, USB connection, and a proprietary physical link.

[0139] In accordance with yet another aspect, the processor may be configured to transmit data packets from the payload device to the remote station through the third communication interface.

[0140] In accordance with still another aspect, the processor may be configured to determine that one of the one or more data packets is designated for the first or second communication interface based on a header of the one data packet.

[0141] In accordance with one aspect, the header may include a port number.

[0142] In accordance with another aspect, the processor may be configured to determine that one of the one or more data packets is designated for the first or second communication interface based on an IP address of the one data packet.

[0143] In accordance with yet another aspect, the processor may be configured to determine that the one data packet is designated for the first or second communication interface based on a subnet of the IP address of the one data packet.

[0144] In accordance with still another aspect, the processor may be configured to receive and authenticate an identity associated with a sender of the one or more data packets prior to transmitting any one of the one or more data packets to the payload device.

[0145] In accordance with one aspect, the first communication interface may be configured to transmit data packets other than control commands, and the second communication interface is configured to transmit control commands for controlling operations of the payload device.

[0146] In accordance with another aspect, the UV may include the payload device.

[0147] In accordance with yet another aspect, the communication module may cause the processor to: monitor a quality of service (QoS) score of a first communication channel associated with the first communication interface; and upon detecting that the QoS score is below a pre-determined threshold, transmit the one or more data packets to the payload device through the second communication interface when the one or more data packets are designated for the first communication interface.

[0148] In accordance with still another aspect, the communication module causes the processor to: monitor a quality of service (QoS) score of a second communication channel associated with the second communication interface; and upon detecting that the

QoS score is below a pre-determined threshold, transmit the one or more data packets to the payload device through the first communication interface when the one or more data packets are designated for the second communication interface.

[0149] In accordance with one aspect, the header may include a port number.

[0150] In accordance with another aspect, a process for receiving and transmitting data by an unmanned vehicle (UV) is provided. The UV may comprise a UAV, UGV, unmanned aquatic vehicle, or any robotic structure (including a fixed structure). The UV comprises a first and a second communication interface for connecting to a payload device, and a third communication interface for communicating with a remote station. The first and second communication interfaces are of different types from each other. The process comprises receiving through the third communication interface one or more data packets from the remote station, transmitting the one or more data packets to the payload device through the first communication interface when the one or more data packets are designated for the first communication interface, and transmitting the one or more data packets to the payload device through the second communication interface when the one or more data packets are designated for the second communication interface.

[0151] In accordance with yet another aspect, the first or second communication interface may include one of: Ethernet connection, Controller Area Network (CAN) Bus connection, serial connection, Inter-integrated Circuit (I2C) connection, printed circuit board (PCB) interface, USB connection, and a proprietary physical link.

[0152] In accordance with still another aspect, the process may include transmitting data packets from the payload device to the remote station through the third communication interface.

[0153] In accordance with one aspect, the process may include determining one of the one or more data packets is designated for the first or second communication interface based on a header of the one data packet.

[0154] In accordance with another aspect, the header may include a port number.

[0155] In accordance with yet another aspect, the process may include determining one of the one or more data packets is designated for the first or second communication interface based on an IP address of the one data packet.

[0156] In accordance with still another aspect, the process may include determining the one data packet is designated for the first or second communication interface based on a subnet of the IP address of the one data packet.

[0157] In accordance with one aspect, the process may include receiving and authenticating an identity associated with a sender of the one or more data packets prior to transmitting any one of the one or more data packets to the payload device.

[0158] In accordance with another aspect, the first communication interface may be configured to transmit data packets other than control commands, and the second communication interface may be configured to transmit control commands for controlling operations of the payload device.

[0159] In accordance with yet another aspect, the process may include monitoring a quality of service (QoS) score of a first communication channel associated with the first second communication interface; and upon detecting that the QoS score is below a pre-determined threshold, transmitting the one or more data packets to the payload device through the second communication interface when the one or more data packets are designated for the first communication interface.

[0160] In accordance with still another aspect, the process may include monitoring a quality of service (QoS) score of a second communication channel associated with the second communication interface; and upon detecting that the QoS score is below a pre-determined threshold, transmitting the one or more data packets to the payload device through the first communication interface when the one or more data packets are designated for the second communication interface.

[0161] In accordance with one aspect, a remote station may be provided. The remote station comprises a processor, a communication interface for communicating with an unmanned vehicle (UV), and a non-transitory memory device storing machine-readable instructions that, when executed by the processor, cause the processor to receive or retrieve an input, process the input into one or more data packets for transmission to a payload device through the UV when the input is for the payload device connected to the UV, and transmit the one or more data packets to the UV through the communication interface for delivery to the payload device. The payload device is connected to the UV through at least two communication interfaces. The two communication interfaces are of different types from each other. The UV may comprise a UAV, UGV, unmanned aquatic vehicle, or any robotic structure (including a fixed structure).

[0162] In accordance with another aspect, the input may be received from a client device.

[0163] In accordance with yet another aspect, the processor may be configured to process the input into one or more data packets by encapsulating some or all of the input within the one or more data packet.

[0164] In accordance with still another aspect, the processor may be configured to process the input for transmission to the payload device through either a first or a second communication interface of the at least two communication interfaces based on a type of the input.

[0165] In accordance with one aspect, the processor may be configured to: when the input is determined to be a control command signal for the payload device, process the input for transmission to the payload device through the first communication interface; and when the input is determined to be a data signal other than a control command signal for the payload device, process the input for transmission to the payload device through the second communication interface.

[0166] In accordance with another aspect, a software development kit (SDK) may be provided. The SDK may be stored on a non-transitory computer readable medium for developing software applications for controlling an unmanned vehicle (UV) and a payload device connected to the UV. The UV may comprise a UAV, UGV, unmanned aquatic vehicle, or any robotic structure (including a fixed structure). The SDK comprises a first application programming interface (API) utilized in developing software applications at a remote station, and a second API utilized in developing the software applications at a remote station. The first API is configured to access the UV to obtain information regarding the UV. The second API is configured to access the payload device to obtain information regarding the payload device. The second API is configured to access the payload device through a communication interface between the remote station and the UV.

[0167] In accordance with still another aspect, the UAV may be connected to the payload device through a first and a second communication interfaces, the first and second communication interfaces being of different types from each other.

[0168] In accordance with one aspect, the first or second API may be configured to access the payload device through one of the first and second communication interfaces.

[0169] In accordance with another aspect, the first API may be configured to: receive, at the remote station, one or more data packets designated for the payload device; transmit the one or more data packets to the payload device through the first communication interface when the one or more data packets are designated for the first communication interface; and transmit the one or more data packets to the payload device through the second communication interface when the one or more data packets are designated for the second communication interface.

[0170] In accordance with yet another aspect, the SDK may provide a graphical user interface for displaying at least one area for entering user input.

[0171] In accordance with still another aspect, the user input may include control command for the UAV or the payload device.

[0172] The embodiments of the devices, systems and processes described herein may be implemented in a combination of both hardware and software. These embodiments may be implemented on programmable computers, each computer including at least one processor, a data storage system (including volatile memory or non-volatile memory or other data storage elements or a combination thereof), and at least one communication interface.

[0173] Program code is applied to input data to perform the functions described herein and to generate output information. The output information is applied to one or more output devices. In some embodiments, the communication interface may be a network communication interface. In embodiments in which elements may be combined, the communication interface may be a software communication interface, such as those for inter-process communication. In still other embodiments, there may be a combination of communication interfaces implemented as hardware, software, and combination thereof.

[0174] Throughout the foregoing discussion, numerous references may be made regarding control and computing devices. It should be appreciated that the use of such terms may represent one or more computing devices having at least one processor configured to execute software instructions stored on a computer readable tangible, non-transitory medium. For example, a remote station **160** or **105** may have a server that includes one or more computers coupled to a web server, database server, or other type of computer server in a manner to fulfill described roles, responsibilities, or functions.

[0175] The foregoing discussion provides many example embodiments. Although each embodiment represents a single combination of inventive elements, other examples may include all possible combinations of the disclosed elements. Thus if one embodiment comprises elements A, B, and C, and a second embodiment comprises elements B and D, other remaining combinations of A, B, C, or D, may also be used.

[0176] The term "connected" or "coupled to" may include both direct coupling (in which two elements that are coupled to each other contact each other) and indirect coupling (in which at least one additional element is located between the two elements).

[0177] The technical solution of embodiments may be in the form of a software product instructing physical operations, such as controlling movement of the UAV 125, for example. The software product may be stored in a non-volatile or non-transitory storage medium, which can be a compact disk read-only memory (CD-ROM), a USB flash disk, or a removable hard disk. The software product includes a number of instructions that enable a computer device (personal computer, server, or network device) to execute the processes

provided by the embodiments.

[0178] The embodiments described herein are implemented by physical computer hardware, including computing devices, servers, receivers, transmitters, processors, memory, displays, and networks. The embodiments described herein provide useful physical machines and particularly configured computer hardware arrangements. The embodiments described herein are directed to electronic machines and processes implemented by electronic machines adapted for processing and transforming electromagnetic signals which represent various types of information. The embodiments described herein pervasively and integrally relate to machines, and their uses; and the embodiments described herein have no meaning or practical applicability outside their use with computer hardware, machines, and various hardware components. Substituting the physical hardware particularly configured to implement various acts for non-physical hardware, using mental steps for example, may substantially affect the way the embodiments work. Such computer hardware limitations are clearly essential elements of the embodiments described herein, and they cannot be omitted or substituted for mental means without having a material effect on the operation and structure of the embodiments described herein. The computer hardware is essential to implement the various embodiments described herein and is not merely used to perform steps expeditiously and in an efficient manner.

[0179] The processor or controller **155**, ground station **160**, or client device **105** may be implemented as a computing device with at least one processor, a data storage device (including volatile memory or non-volatile memory or other data storage elements or a combination thereof), and at least one communication interface. The computing device components may be connected in various ways including directly coupled, indirectly coupled via a network, and distributed over a wide geographic area and connected via a network (which may be referred to as "cloud computing").

[0180] For example, and without limitation, the computing device may be a server, network appliance, microelectromechanical Systems (MEMS) or micro-size mechanical devices, set-top box, embedded device, computer expansion module, personal computer, laptop, personal data assistant, cellular telephone, smartphone device, UMPC tablets, video display terminal, gaming console, electronic reading device, and wireless hypermedia device or any other computing device capable of being configured to carry out the processes described herein.

[0181] A processor may be, for example, a general-purpose microprocessor or microcontroller, a digital signal processing (DSP) processor, an integrated circuit, a field programmable gate array (FPGA), a reconfigurable processor, a programmable read-only

memory (PROM), or any combination thereof.

[0182] Data storage device may include a suitable combination of any type of computer memory that is located either internally or externally such as, for example, random-access memory (RAM), read-only memory (ROM), compact disc read-only memory (CDROM), electro-optical memory, magneto-optical memory, erasable programmable read-only memory (EPROM), and electrically-erasable programmable read-only memory (EEPROM), Ferroelectric RAM (FRAM) or the like.

[0183] Computing device may include an I/O interface to enable computing device to interconnect with one or more input devices, such as a keyboard, mouse, camera, touch screen and a microphone, or with one or more output devices such as a display screen and a speaker.

[0184] Although the embodiments have been described in detail, it should be understood that various changes, substitutions and alterations can be made herein without departing from the scope as defined by the appended claims.

[0185] Moreover, the scope of the present application is not intended to be limited to the particular embodiments of the process, machine, manufacture, composition of matter, means, processes and steps described in the specification. As one of ordinary skill in the art will readily appreciate from the disclosure of the present invention, processes, machines, manufacture, compositions of matter, means, processes, or steps, presently existing or later to be developed, that perform substantially the same function or achieve substantially the same result as the corresponding embodiments described herein may be utilized. Accordingly, the appended claims are intended to include within their scope such processes, machines, manufacture, compositions of matter, means, processes, or steps.

[0186] As can be understood, the examples described above and illustrated are intended to be exemplary only. The scope is indicated by the appended claims.

CLAIMS

1. An unmanned vehicle (UV), comprising:
 - a processor configured to control operations of the UV;
 - a first and a second communication interface for connecting to a payload device, the first and second communication interfaces being of different types from each other;
 - a third communication interface for communicating with a remote station; and
 - a non-transitory memory device storing machine-readable instructions that, when executed by the processor, causes the processor to receive and transmit data, the processor configured to:
 - receive, through the third communication interface, one or more data packets from the remote station;
 - transmit the one or more data packets to the payload device through the first communication interface when the one or more data packets are designated for the first communication interface; and
 - transmit the one or more data packets to the payload device through the second communication interface when the one or more data packets are designated for the second communication interface.
2. The UV as claimed in claim 1, wherein at least one of the first communication interface or the second communication interface comprises one of: Ethernet connection, Controller Area Network (CAN) Bus connection, serial connection, Inter-integrated Circuit (I²C) connection, printed circuit board (PCB) interface, USB connection, a proprietary physical link, or a wireless connection.
3. The UV as claimed in claim 1, wherein the first and second communication interfaces comprises logical interfaces implemented through at least one hardware interface.
4. The UV as claimed in claim 1, wherein the processor is configured to transmit data packets from the payload device to the remote station through the third communication interface.
5. The UV as claimed in claim 1, wherein the processor is configured to determine that one of the one or more data packets is designated for the first or second communication interface based on a header of the one data packet.
6. The UV as claimed in claim 5, wherein the header comprises a port number.

7. The UV as claimed in claim 1, wherein the processor is configured to determine that one of the one or more data packets is designated for the first or second communication interface based on an IP address of the one data packet.
8. The UV as claimed in claim 7, wherein the processor is configured to determine that the one data packet is designated for the first or second communication interface based on a subnet of the IP address of the one data packet.
9. The UV as claimed in claim 1, wherein the processor is configured to receive and authenticate an identity associated with a sender of the one or more data packets prior to transmitting any one of the one or more data packets to the payload device.
10. The UV as claimed in claim 1, wherein the first communication interface is configured to transmit data packets other than control commands, and the second communication interface is configured to transmit control commands for controlling operations of the payload device.
11. The UV as claimed in claim 1, wherein the UV includes the payload device.
12. The UV as claimed in claim 1, wherein the processor is configured to:
 - monitor a quality of service (QoS) score of a first communication channel associated with one of the first and second communication interface; and
 - upon detecting that the QoS score is below a pre-determined threshold, transmit the one or more data packets to the payload device through the other of the first and second communication interface.
13. A process for receiving and transmitting data by an unmanned vehicle (UV), the UV comprising:
 - a first and a second communication interface for connecting to a payload device, and a third communication interface for communicating with a remote station, the first and second communication interfaces being of different types from each other, the process comprising:
 - receiving, through the third communication interface, one or more data packets from the remote station;
 - transmitting the one or more data packets to the payload device through the first communication interface when the one or more data packets are designated for the first communication interface; and

transmitting the one or more data packets to the payload device through the second communication interface when the one or more data packets are designated for the second communication interface.

14. The process as claimed in claim 13, wherein at least one of the first communication interface or the second communication interface comprises one of: Ethernet connection, Controller Area Network (CAN) Bus connection, serial connection, Inter-integrated Circuit (I²C) connection, printed circuit board (PCB) interface, USB connection, and a proprietary physical link.
15. The process as claimed in claim 1, wherein the first and second communication interfaces comprises logical interfaces implemented through at least one hardware interface.
16. The process as claimed in claim 13, comprising determining one of the one or more data packets is designated for the first or second communication interface based on a header of the one data packet.
17. The process as claimed in claim 16, wherein the header comprises a port number.
18. The process as claimed in claim 13, comprising determining one of the one or more data packets is designated for the first or second communication interface based on an IP address of the one data packet.
19. The process as claimed in claim 18, comprising determining the one data packet is designated for the first or second communication interface based on a subnet of the IP address of the one data packet.
20. The process as claimed in claim 13, comprising receiving and authenticating an identity associated with a sender of the one or more data packets prior to transmitting any one of the one or more data packets to the payload device.
21. The process as claimed in claim 13, wherein the first communication interface is configured to transmit data packets other than control commands, and the second communication interface is configured to transmit control commands for controlling operations of the payload device.
22. The process as claimed in claim 13, comprising:
 - monitoring a quality of service (QoS) score of a first communication channel associated with one of the first and second communication interface; and

upon detecting that the QoS score is below a pre-determined threshold, transmitting the one or more data packets to the payload device through the other of the first and second communication interface.

23. A remote station comprising:

a processor;

a communication interface for communicating with an unmanned vehicle (UV); and

a non-transitory memory device storing machine-readable instructions that, when executed by the processor, causes the processor to receive and transmit data, the processor configured to:

receive or retrieve an input;

process the input into one or more data packets for transmission to a payload device through the UV when the input is for the payload device connected to the UV; and

transmit the one or more data packets to the UV through the communication interface for delivery to the payload device, wherein the payload device is connected to the UAV through at least two communication interfaces, the two communication interfaces being of different types from each other.

24. The remote station as claimed in claim 23, wherein the input is received from a client device.

25. The remote station as claimed in claim 23, wherein the processor is configured to process the input into one or more data packets by encapsulating some or all of the input within the one or more data packet.

26. The remote station as claimed in claim 25, wherein the processor is configured to process the input for transmission to the payload device through either a first or a second communication interface of the at least two communication interfaces based on a type of the input.

27. The remote station as claimed in claim 26, wherein the processor is configured to:

when the input is determined to be a control command signal for the payload device, process the input for transmission to the payload device through the first communication interface; and

when the input is determined to be a data signal other than a control command signal

for the payload device, process the input for transmission to the payload device through the second communication interface.

28. A software development kit (SDK) stored on a non-transitory computer readable medium for developing software applications for controlling an unmanned vehicle (UV) and a payload device connected to the UV, the SDK comprising:

a first application programming interface (API) utilized in developing software applications at a remote station, the first API configured to access the UV to obtain information regarding the payload device;

wherein the first API is configured to access the payload device through a communication interface between the remote station and the UV.

29. The SDK as claimed in claim 28, comprising a second API utilized in developing software applications at a remote station, the second API configured to access the UV to obtain information regarding the UV.

30. The SDK as claimed in claim 29, wherein the UV is connected to the payload device through a first and a second communication interface, the first and second communication interfaces being of different types from each other, and the first or second API is configured to access the payload device through one of the first and second communication interfaces.

31. The SDK as claimed in claim 30, wherein the first API is configured to:

receive, at the remote station, one or more data packets designated for the payload device;

transmit the one or more data packets to the payload device through the first communication interface when the one or more data packets are designated for the first communication interface; and

transmit the one or more data packets to the payload device through the second communication interface when the one or more data packets are designated for the second communication interface.

32. The SDK as claimed in claim 30, comprising a graphical user interface for displaying at least one area for entering user input.

33. The SDK as claimed in claim 32, wherein the user input comprise a control command for the UV or the payload device.

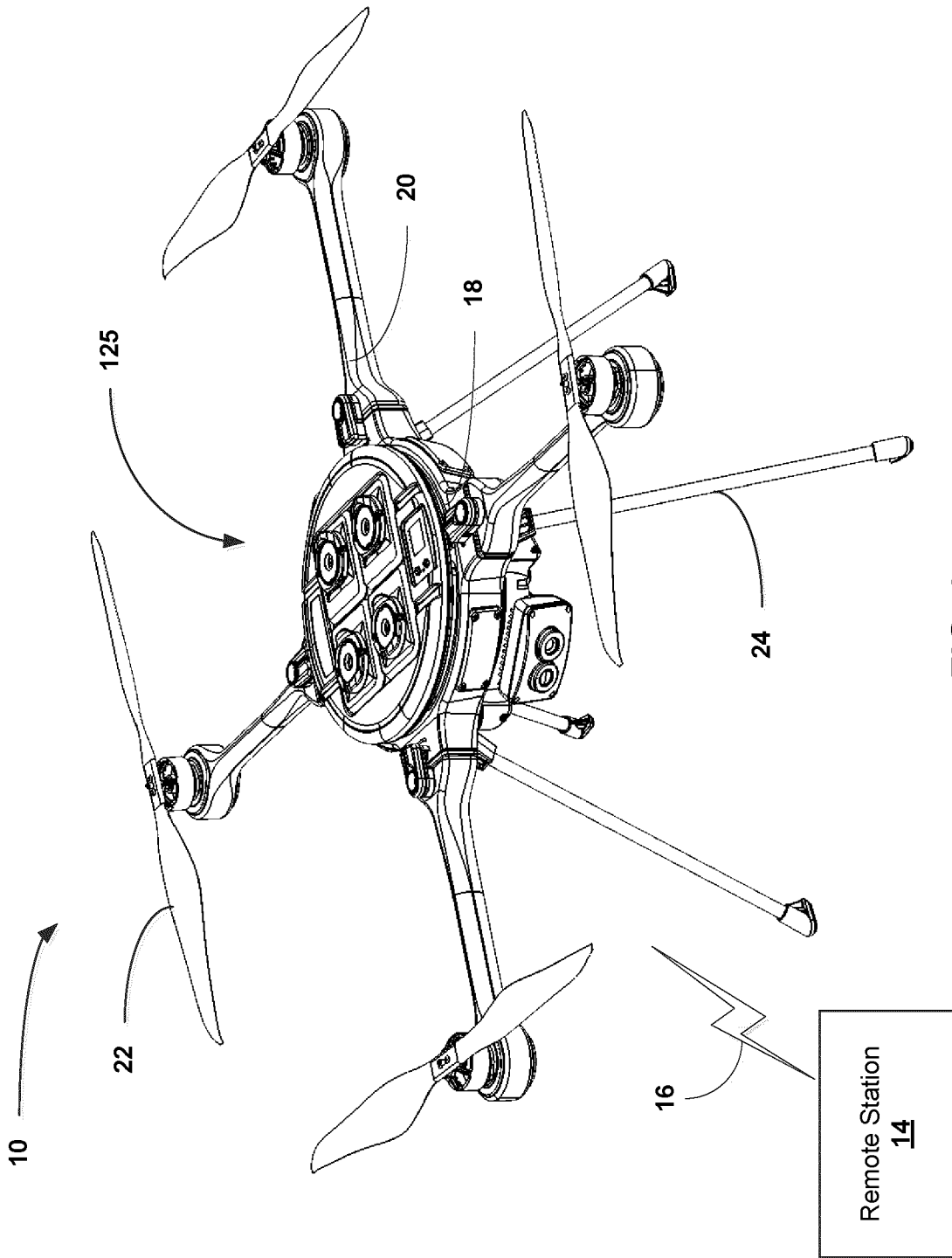

FIG. 1

2/9

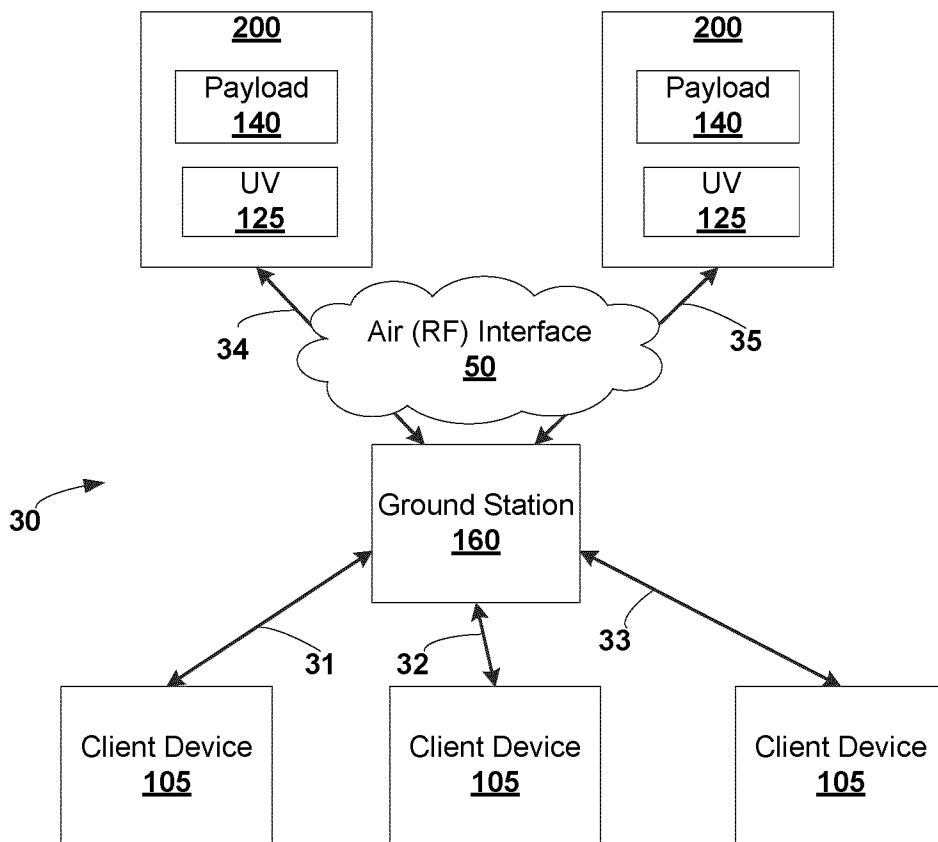

FIG. 2

3/9

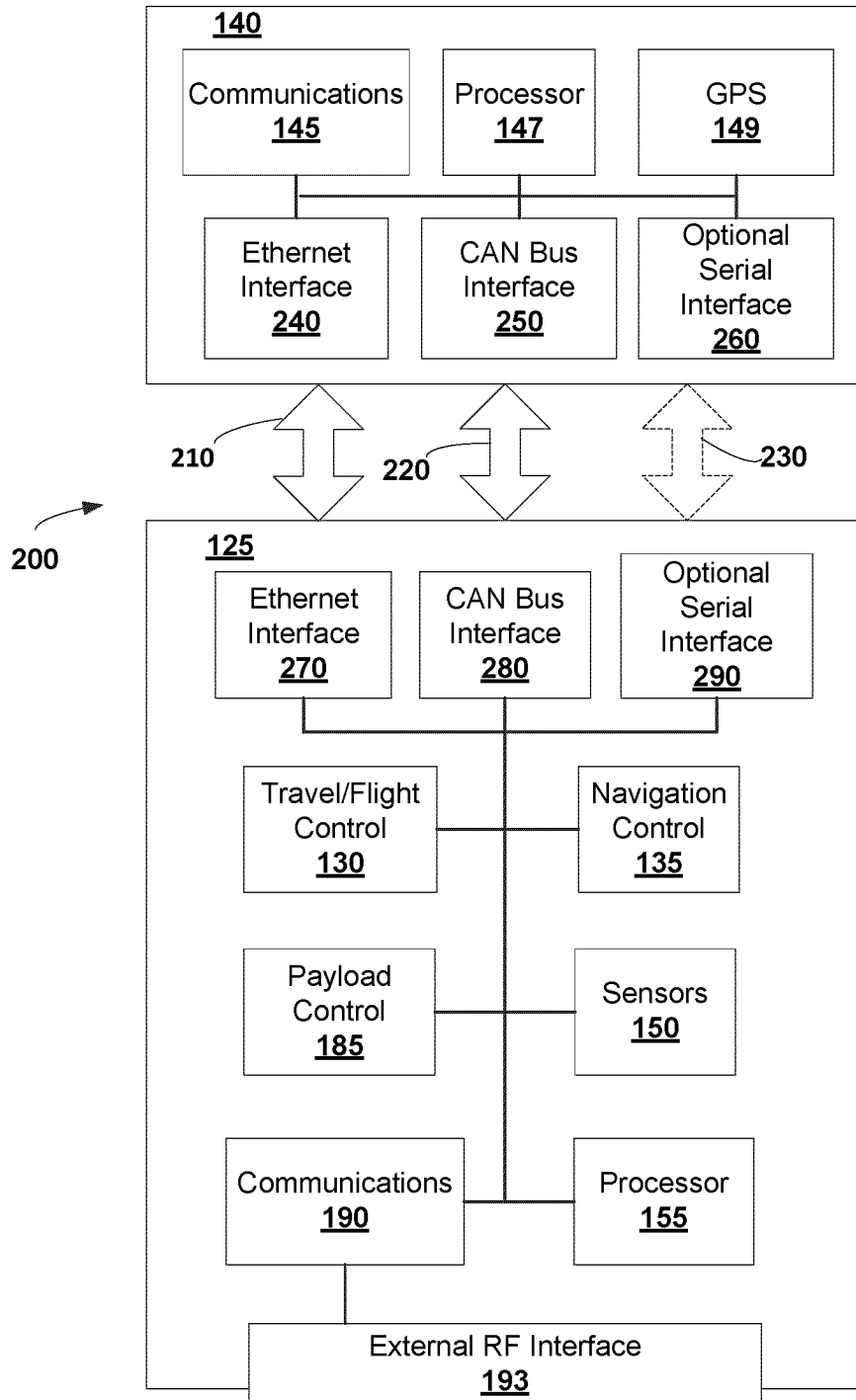

FIG. 3

4/9

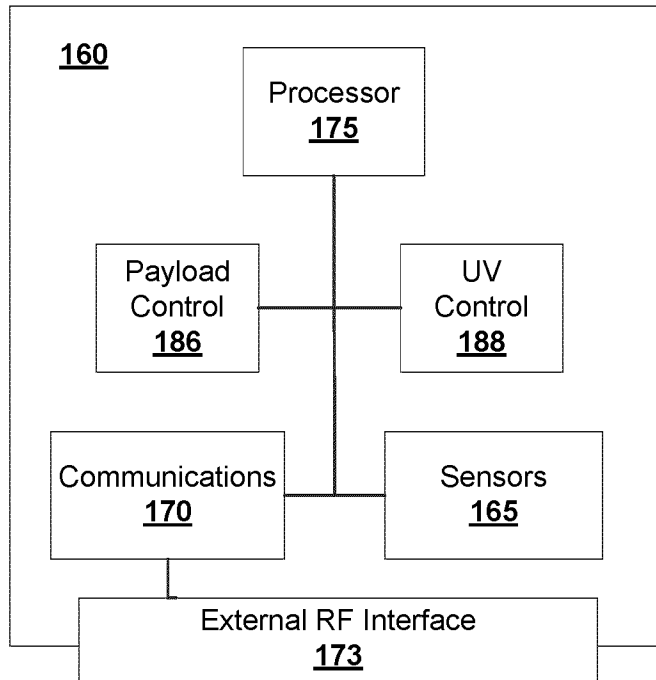

FIG. 4

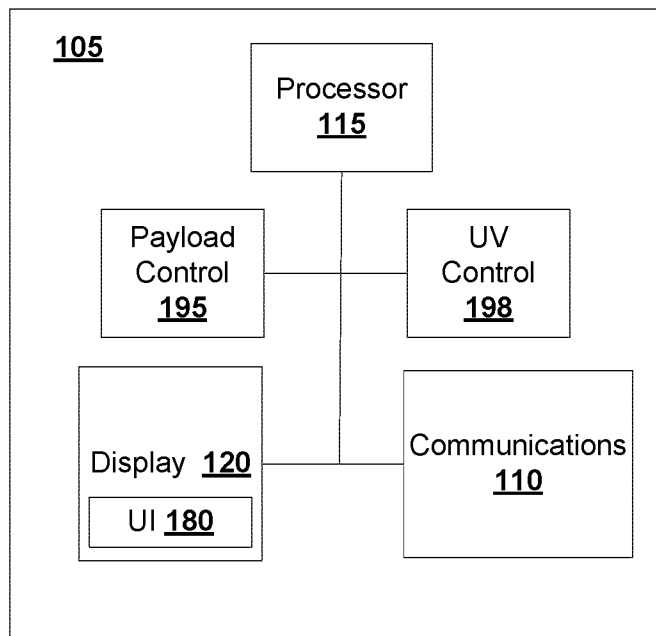

FIG. 5A

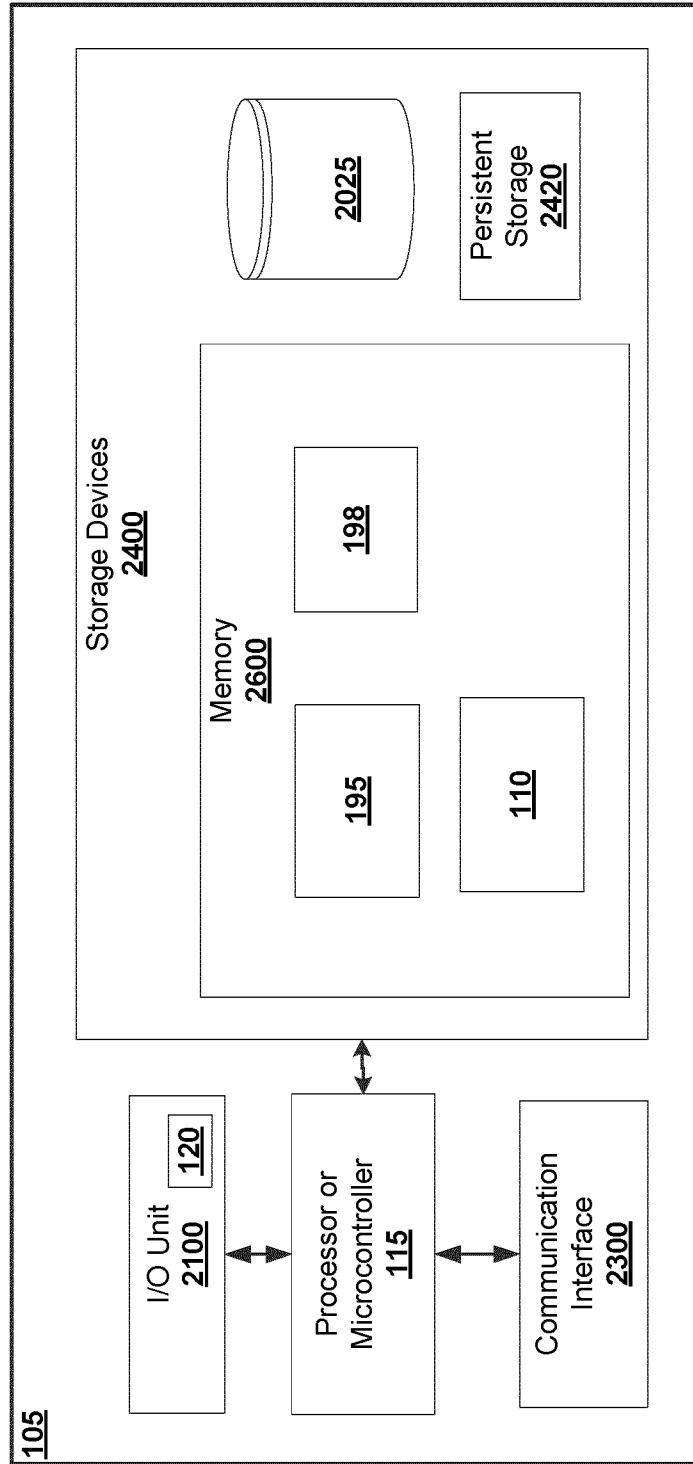

FIG. 5B

6/9

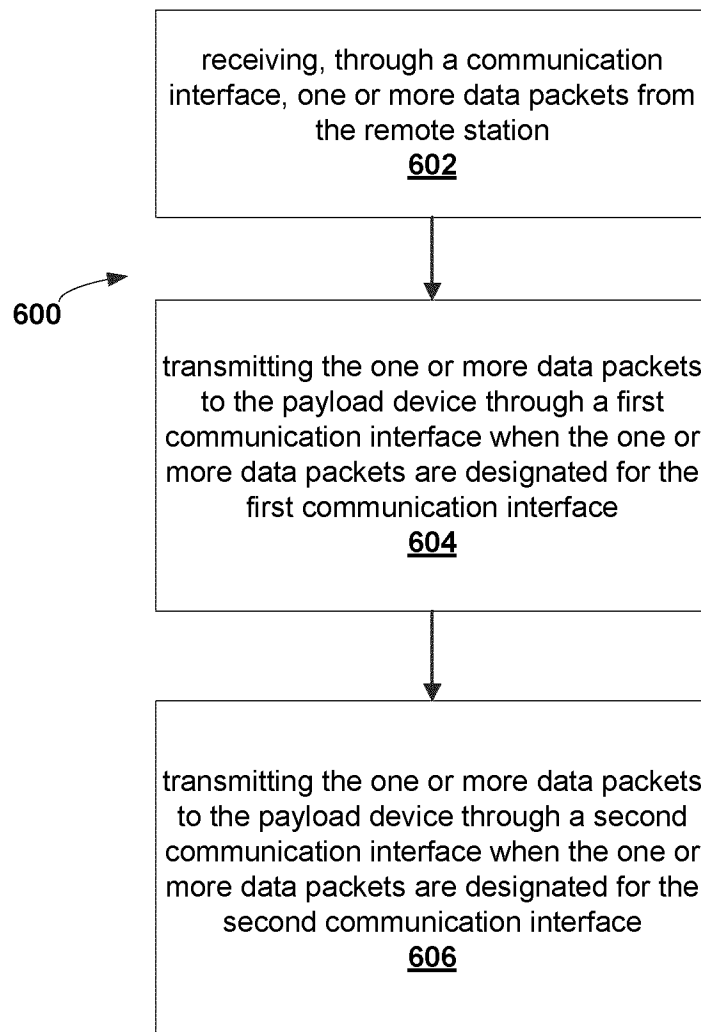

FIG. 6

7/9

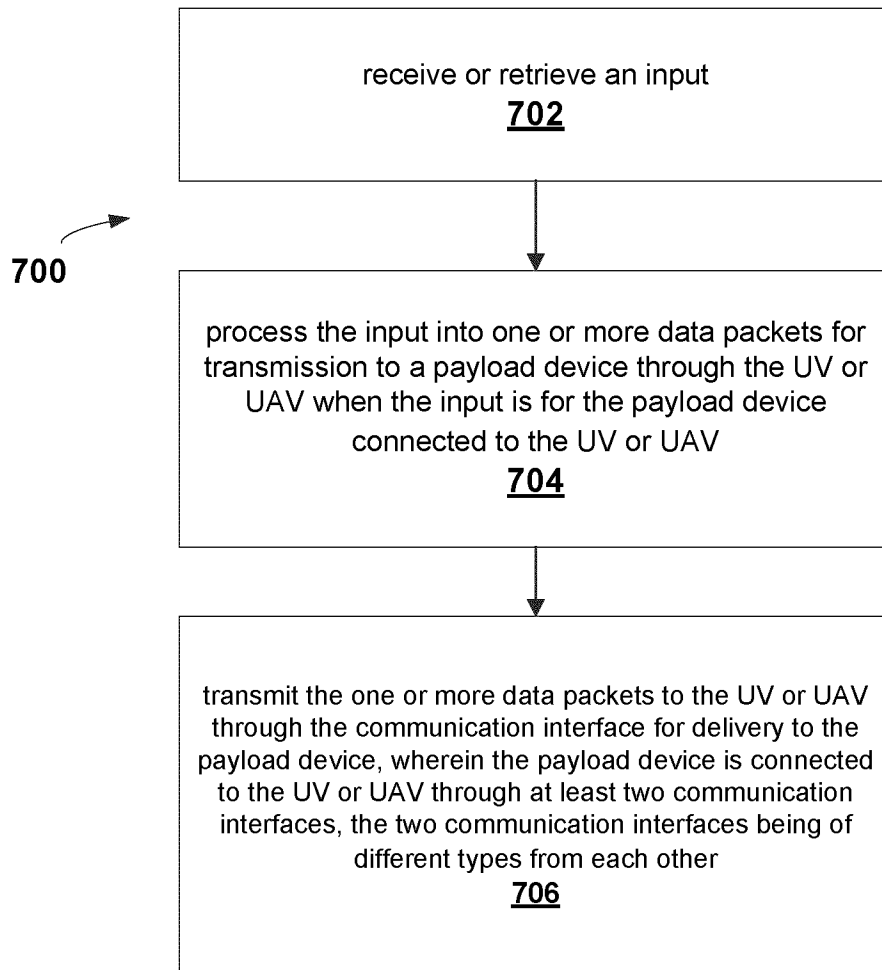

FIG. 7

8/9

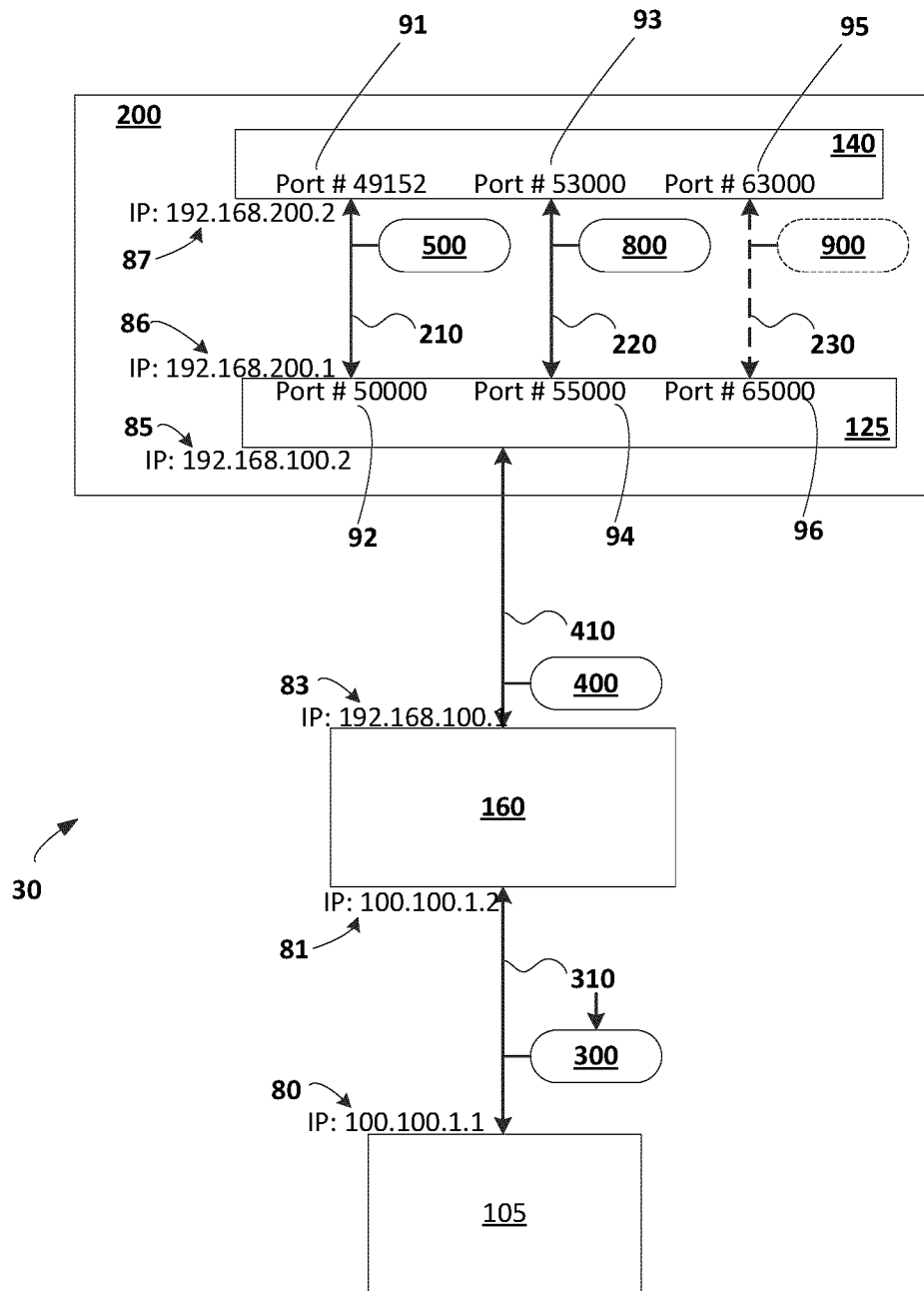

FIG. 8

9/9

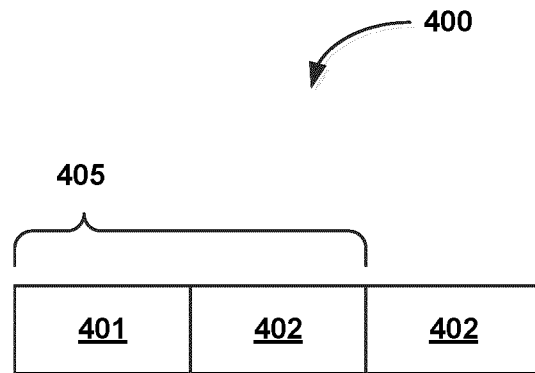

FIG. 9

INTERNATIONAL SEARCH REPORT

International application No.
PCT/CA2019/050527

A. CLASSIFICATION OF SUBJECT MATTER
 IPC: **H04L 12/28** (2006.01), **H04L 9/32** (2006.01), **H04W 80/02** (2009.01), **H04W 84/00** (2009.01)

According to International Patent Classification (IPC) or to both national classification and IPC

B. FIELDS SEARCHED

Minimum documentation searched (classification system followed by classification symbols)
 IPC: H04L 12/28 (2006.01), H04L 9/32 (2006.01), H04W 80/02 (2009.01), H04W 84/00 (2009.01)

Documentation searched other than minimum documentation to the extent that such documents are included in the fields searched

Electronic database(s) consulted during the international search (name of database(s) and, where practicable, search terms used)

Databases: Questel Orbit; Google Patents

Keywords: uav; communication; interface+; qos; packet+; payload; unmanned; vehicle; header; ip; port; quality; service

C. DOCUMENTS CONSIDERED TO BE RELEVANT

Category*	Citation of document, with indication, where appropriate, of the relevant passages	Relevant to claim No.
X Y	US20070198144 A1, Norris et al., 23 August 2007 (23-08-2007) * Fig. 1, paragraphs [0011-0078]	1-8, 10, 11, 13-19, 21 and 23-33 9, 12, 20 and 22
Y	US20170295069 A1, Sweet III et al., 12 October 2017 (12-10-2017) * paragraphs [0022-0065]	9, 12, 20 and 22
A	Marques, "STANAG 4586 - Standard Interfaces of UAV Control System (UCS) for NATO UAV Interoperability", STANAG 4586 Ed.3, NATO Standardization Agency (NSA), 30 November 2012 (30-11-2012), Pages 3-1 to 3-14, * Entire document	1-33

Further documents are listed in the continuation of Box C.

See patent family annex.

* "A" "E" "L" "O" "P"	Special categories of cited documents: document defining the general state of the art which is not considered to be of particular relevance earlier application or patent but published on or after the international filing date document which may throw doubts on priority claim(s) or which is cited to establish the publication date of another citation or other special reason (as specified) document referring to an oral disclosure, use, exhibition or other means document published prior to the international filing date but later than the priority date claimed	"T" "X" "Y" "&"	later document published after the international filing date or priority date and not in conflict with the application but cited to understand the principle or theory underlying the invention document of particular relevance; the claimed invention cannot be considered novel or cannot be considered to involve an inventive step when the document is taken alone document of particular relevance; the claimed invention cannot be considered to involve an inventive step when the document is combined with one or more other such documents, such combination being obvious to a person skilled in the art document member of the same patent family
--------------------------------------	--	--------------------------	--

Date of the actual completion of the international search
07 June 2019 (07-06-2019)

Date of mailing of the international search report
10 June 2019 (10-06-2019)

Name and mailing address of the ISA/CA
 Canadian Intellectual Property Office
 Place du Portage I, C114 - 1st Floor, Box PCT
 50 Victoria Street
 Gatineau, Quebec K1A 0C9
 Facsimile No.: 819-953-2476

Authorized officer
 Leslie Yeow (819) 639-8372

INTERNATIONAL SEARCH REPORT
Information on patent family members

International application No.
PCT/CA2019/050527

Patent Document Cited in Search Report	Publication Date	Patent Family Member(s)	Publication Date		
US2007198144A1	23 August 2007 (23-08-2007)	US8473140B2	25 June 2013 (25-06-2013)		
		AU2006304812A1	26 April 2007 (26-04-2007)		
		AU2006304812B2	02 February 2012 (02-02-2012)		
		AU2006304838A1	26 April 2007 (26-04-2007)		
		AU2006304838B2	28 July 2011 (28-07-2011)		
		AU2006306522A1	03 May 2007 (03-05-2007)		
		AU2006306522B2	28 July 2011 (28-07-2011)		
		AU2006306522B9	08 December 2011 (08-12-2011)		
		AU2006306523A1	03 May 2007 (03-05-2007)		
		AU2006306523B2	19 May 2011 (19-05-2011)		
		DE112006002892T5	06 November 2008 (06-11-2008)		
		DE112006002894T5	18 September 2008 (18-09-2008)		
		DE112006003007T5	16 October 2008 (16-10-2008)		
		DE112006003044T5	23 October 2008 (23-10-2008)		
		GB0807131D0	21 May 2008 (21-05-2008)		
		GB2445507A	09 July 2008 (09-07-2008)		
		GB2445507B	24 August 2011 (24-08-2011)		
		IL191001A	30 April 2013 (30-04-2013)		
		US2007198145A1	23 August 2007 (23-08-2007)		
		US7894951B2	22 February 2011 (22-02-2011)		
		US2007193798A1	23 August 2007 (23-08-2007)		
		US8020657B2	20 September 2011 (20-09-2011)		
		US2012046820A1	23 February 2012 (23-02-2012)		
		US8874300B2	28 October 2014 (28-10-2014)		
		US2007219666A1	20 September 2007 (20-09-2007)		
		US9043016B2	26 May 2015 (26-05-2015)		
		US2011071718A1	24 March 2011 (24-03-2011)		
		US9098080B2	04 August 2015 (04-08-2015)		
		US2014350768A1	27 November 2014 (27-11-2014)		
		US9429944B2	30 August 2016 (30-08-2016)		
		US2015301532A1	22 October 2015 (22-10-2015)		
		WO2007048003A2	26 April 2007 (26-04-2007)		
		WO2007048003A3	02 August 2007 (02-08-2007)		
		WO2007048029A2	26 April 2007 (26-04-2007)		
		WO2007048029A3	26 July 2007 (26-07-2007)		
		WO2007050406A1	03 May 2007 (03-05-2007)		
		WO2007050407A1	03 May 2007 (03-05-2007)		
		US2017295069A1	12 October 2017 (12-10-2017)	CN108886428A	23 November 2018 (23-11-2018)
				TW201737727A	16 October 2017 (16-10-2017)
				WO2017176350A1	12 October 2017 (12-10-2017)