



Europäisches Patentamt
 European Patent Office
 Office européen des brevets



(11) **EP 0 973 176 A1**

(12) **EUROPEAN PATENT APPLICATION**

(43) Date of publication:
 19.01.2000 Bulletin 2000/03

(51) Int Cl.7: **H01C 7/102**, H01C 1/14,
 H01C 17/28

(21) Application number: **98305676.3**

(22) Date of filing: **16.07.1998**

(84) Designated Contracting States:
**AT BE CH CY DE DK ES FI FR GB GR IE IT LI LU
 MC NL PT SE**
 Designated Extension States:
AL LT LV MK RO SI

(72) Inventor: **McLoughlin, Neil
 Blackrock, County Louth (IE)**

(74) Representative: **van Berlyn, Ronald Gilbert
 23, Centre Heights
 London NW3 6JG (GB)**

(71) Applicant: **HARRIS CORPORATION
 Melbourne Florida 32912 (US)**

(54) **Nickel barrier end termination and method**

(57) A method of providing nickel barrier end terminations for a zinc oxide semiconductor device with exposed body surfaces and end terminal regions, in which

the device is controllably reacted with a nickel plating solution only on an exposed end terminal region and thereafter provided with a final tin or tin-lead termination.

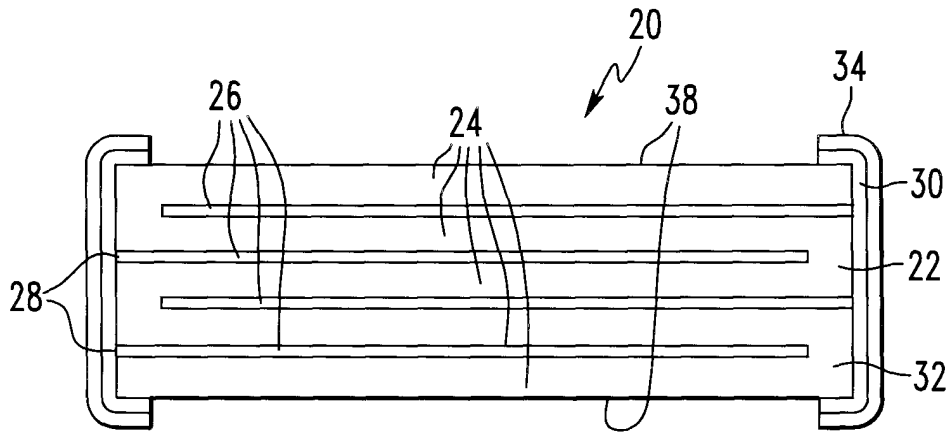

FIG. 2

EP 0 973 176 A1

Description

[0001] The present invention relates to nonlinear resistive devices, such as varistors, and more particularly to methods of making such devices using controllable plating techniques in which the exposed end terminals of the device are plated with nickel barrier terminations while the exposed semiconductor body remains unplated.

[0002] Nonlinear resistive devices are known, and are disclosed, in the specification of U.S. Patent No. 5,115,221.

[0003] Figure 1 shows a device 10 that includes plural layers 12 of semiconductor material with electrically conductive electrodes 14 between adjacent layers. A portion of each electrode 14 is exposed in a terminal region 16 so that electrical contact may be made therewith. The electrodes 14 may be exposed at one or both of opposing terminal regions, and typically the electrodes are exposed at alternating terminal regions 16 as illustrated. The exposed portions of the electrodes 14 are contacted by electrically conductive end terminals 18 that cover the terminal regions 16.

[0004] The attachment of the end terminals 18 has proved to be a difficult problem in search of a simplified solution. Desirably, the terminal regions 16 may be plated with nickel and tin-lead metals to increase solderability and decrease solder leaching. The process parameters in plating nickel to zinc oxide semiconductor bodies has proved particularly vexing and has required complex solutions.

[0005] One method of affixing the end terminals 18 is to use a conventional barrel plating method in which the entire device is immersed in a plating solution. However, the stacked layers are semiconductor material, such as zinc oxide, that may be conductive during the plating process so that the plating adheres to the entire surface of the device. Thus, in order to provide separate end terminals as shown in Figure 1, a portion of the plating must be mechanically removed after immersion, or covered before immersion with a temporary plating resist comprised of an organic substance insoluble to the plating solution. However, the removal of the plating or organic plating resist is an extra step in the manufacturing process, and may involve the use of toxic materials that further complicate the manufacturing process.

[0006] It has also been suggested that the metal forming the end terminals 18 be flame sprayed onto the device, with the other portions of the surface of the device being masked. Flame spraying is not suitable for many manufacturing processes because it is slow and includes the creation of a special mask, with the additional steps attendant therewith. As disclosed in the specification of U.S. Patent No. 4,316,171.

It is also known to react a semiconductor body, having electrically conductive metal end terminations, with phosphoric acid to selectively form a phosphate on the semiconductor body prior to providing end terminations

using conventional barrel plating. As disclosed in the specification of U.S. Patent No. 5,614,074.

[0007] The present invention includes a method of making a semiconductor device, the body of the semiconductor device having an exposed zinc oxide surface and nickel end terminations, the method comprising the steps of providing a semiconductor body having electrically conductive plates interleaved with zinc oxide layers, providing a selected nickel plating solution for an intended method of nickel plating, and controllably contacting an end of the semiconductor body with the nickel plating solution in order to form a desirably thick nickel barrier cap over the end of the semiconductor body without forming a nickel barrier cap over the entire semiconductor body, in which the temperature of the nickel plating solution is uncontrolled and remains at approximately room temperature.

[0008] The invention also includes a method of providing a semiconductor device having a body with an exposed zinc oxide surface and electrically conductive, solderable metal end terminations, the method comprising the steps of providing a semiconductor body having electrically conductive plates interleaved with zinc oxide layers, applying a termination material comprising silver and glass frit onto opposing ends of the semiconductor body, mechanically bonding the termination material to the ends of the semiconductor body by firing, providing at a temperature of about 50 to 70°C a nickel plating solution comprising one or more of (i) nickel sulphate or nickel chloride, (ii) boric acid, (iii) a wetting agent, and (iv) a stress relieving agent, coating a silver terminated end of the semiconductor body by selectively partially immersing the end of the semiconductor body in the nickel plating solution for a period of about 15 to about 120 minutes while applying a biasing current of about 0.3 to 2.0 A/dm² whereby to form a desirably thick nickel barrier cap in contact with the silver terminated end which extends a selected distance up the body of the semiconductor device; providing a final termination solution of one or more of alkyl-tin, alkyl-tin-lead, tin-sulfuric acid or tin-lead-sulfuric acid, having a pH from about 3 to about 6 and an uncontrolled temperature; and forming a desirably thick, electrically conductive, solderable contact end termination over the nickel barrier cap by selectively partially immersing the end of the semiconductor body into the final termination solution for a period of about 10 to about 120 minutes while applying a biasing current of about 0.3 to about 2.0 A/dm², in which the pH of the nickel plating solution is maintained between about 2 and about 6.

[0009] An object of the present invention is to provide a method and device that obviates many known problems, and provides a method of manufacturing a semiconductor device by controllably reacting an exposed zinc oxide semiconductor device having an exposed end terminal region with a nickel plating solution to form a nickel barrier end termination over the semiconductor body end without plating the entire exposed semicon-

ductor device.

[0010] Another object is to provide a method of providing a semiconductor device by controllably partially immersing an exposed semiconductor body having a silver termination with a nickel plating solution while applying a biasing current to form a nickel barrier cap extending a selected distance up the exposed body of the semiconductor device, and to provide a novel method of providing a semiconductor body with a nickel barrier cap without the use of a plating resist by positioning an exposed end of the semiconductor body a selectable distance into a nickel plating solution for a controlled period.

[0011] The invention will now be described, by way of example, with reference to the accompanying drawings in which:

[0012] Figure 1 is a pictorial depiction of a prior art varistor.

[0013] Figure 2 is a vertical cross section of an embodiment of the device of the present invention.

[0014] Figure 3 is a vertical cross section of another embodiment of the device of the present invention.

[0015] Figure 2 shows an embodiment of a nonlinear resistive element 20 that include a body 22 having stacked zinc oxide semiconductor layers 24 with generally planar electrodes 26 between adjacent pairs of layers 24. The zinc oxide layers 24 need not be comprised of pure zinc oxide and may be comprised of a ceramic consisting principally of zinc oxide. Each electrode 26 may have a contactable portion 28 that is exposed for electrical connection to nickel barrier end terminations 30 that cover terminal regions 32 of the body 22 and contact the electrodes 26. The exterior portion of body 22 not covered with the end terminations 30 remain as exposed zinc oxide surface 38. Nickel barrier end terminations 30 may be plated with layers 34 of electrically conductive, solderable tin or tin-lead metal that form electrically contactable solderable end portions for the resistive element 20.

[0016] Figure 3 shows another embodiment of a nonlinear resistive manufactured using the method of the present invention, element 20 includes body 22 having stacked zinc oxide semiconductor layers 24 and generally planar electrodes 26 between adjacent pairs of layers 24. Each electrode 26 may have a contactable portion 28 exposed for electrical connection to a first electrically conductive metal (preferably silver, platinum-free silver, or palladium-free silver) end terminations 36 with nickel barrier end terminations 30 thereupon, covering terminal regions 32 and extending a desired distance along the body 22. As with the embodiment illustrated by Figure 2, nickel barrier end terminations 30 may be plated with layers 34 of solderable tin or tin-lead metal that form final electrically contactable end portions for the resistive element 20.

[0017] In one embodiment the zinc oxide layers 24 may have the following composition in mole percent: 94-98% zinc oxide and 2-6% of one or more of the fol-

lowing additives; bismuth oxide, cobalt oxide, manganese oxide, nickel oxide, antimony oxide, boric oxide, chromium oxide, silicon oxide, aluminum nitrate, and other equivalents.

[0018] In a first embodiment of the method, the body 22 is provided conventionally, electrodes 26 having contactable portions 28 exposed for electrical connection at terminal regions 32 with the remaining portions of body 22 being exposed zinc oxide surface 38. Process parameter control to avoid process boundary problems including: 1) plating not occurring, 2) plating not uniformly covering terminal regions 32, 3) plating too thick or thin; and 4) plating spread beyond the desired terminal region 32 onto exposed zinc oxide surface 38, requires the selection of nickel plating solution appropriate for an intended method of nickel barrier end termination plating-electroplating electroless plating, or brush plating. Having determined the method of nickel plating, an end of body 22 controllable contacts the nickel plating solution to form a desirably thick nickel barrier end terminations 30 over terminal region 32. Complimentary parameter processes selection, identification of nickel plating solution, plating method, and controllable contact assures that nickel barrier end terminations 30 uniformly cover terminal region 32 without extending undesirably along exposed surface 38 and while avoiding unacceptable zinc oxide etching, which etching is known to cause electrical leakage currents and mechanical weakness in the final device.

[0019] With the appropriate parameter selection, the method of the present invention allows the temperature of the nickel plating solution to remain uncontrolled such that the solution remains at approximately room temperature. The pH of the nickel plating solution may be maintained between 2 and 6. Contact between semiconductor body 22 and nickel plating solution may vary from 15 to 120 minutes to allow the formation of end termination 30 with a thickness between 1 and 3 μm .

[0020] One embodiment includes forming solderable contact 34 over end termination 30 by controllably immersing the nickel termination 30 into a room temperature solution containing one of Alkyl-tin, Alkyl-tin-lead, Tin-Lead sulfuric acid, or tin sulfuric acid having a pH from 2 to 6. The partial immersion may vary in the range from 10 to 120 minutes to allow the formation of solderable contact 34 with a cap thickness ranging from 3 to 6 μm . Desirably, solderable contact plating may include application of a biasing current of approximately 0.3 to 2.0 A/dm².

[0021] Another embodiment is suited to electroless and brush plating methods for forming nickel end terminations 30. For this embodiment, a nickel plating solution comprising a room temperature solution of nickel sulphate, dimethylamineborane, lactic acid, ammonium citrate, and ammonia may be used in combination with semiconductor body 22 having zinc oxide layers 24 with a resistivity in the range from 10¹⁰ to 10¹² Ohms/cm. The pH of the nickel plating solution may be maintained

between 2 and 6.

[0022] For electroless plating, one end of semiconductor body 22 is positioned a selectable distance into the nickel plating solution covering that end of body 22 and allowing the plating solution to travel up a portion of exposed zinc oxide surface 38. Maintaining body 22 immersed for a period of 15 to 120 minutes provides for a nickel cap between 1 and 3 μm .

[0023] For brush plating, a suitable absorbent material is impregnated with the nickel plating solution. One end of semiconductor body 22 is placed in contact with the impregnated absorbent material such that terminal region 32 completely contacts the absorbent material. Pressure between body 22 and absorbent material is maintained to allow formation of nickel end termination 30 on terminal region 32 and a desired distance along exposed zinc surface 38. The contact period may vary between 15 and 120 minutes to control termination 30 thickness and travel up surface 38. Relative motion may be provided so that semiconductor body 22 moves relative to the absorbent material.

[0024] In another embodiment, particularly suitable for electroplating, a first electrically conductive metal end termination 36 is provided intermediate end termination 30 and body 20 and further includes providing a nickel plating solution comprising one of nickel sulphate or nickel chloride, boric acid, a wetting agent, and a stress relieving agent with the plating solution maintained at a temperature of 50 to 70°C. First end termination 36 material may preferably comprise silver, platinum-free silver, and/or palladium-free silver and glass frit. The use of platinum-free and/or palladium-free silver reduces the cost of device manufacture. The silver/glass frit material may be conventionally applied onto opposing ends of body 20 and fired to mechanically bond the silver/glass frit materials to terminal regions 32 forming first end terminations 36. Firing temperatures of 550 to 800°C have provided favorable results.

[0025] Body 20 with first end termination 36 is partially immersed into the nickel plating solution for a period from 15 to 120 minutes while applying biasing current of 0.3 to 2.0 A/dm². Various controlling immersion depth, immersion time, and biasing current will control nickel barrier termination 30 thickness and travel upward along exposed zinc surface 38.

[0026] Optionally, a final solderable termination may be provided over nickel end termination 30 using a room temperature solution of one of Alkyl-tin, Alkyl-tin-lead, Tin-Lead sulfuric acid, or tin sulfuric acid. Solder plating solutions having a pH in the range of approximately 3 to 6 have been suitable when layers 34 are formed with an immersion period ranging from 10 to 120 minutes and a biasing current of 0.3 to 2.0 A/dm². In the present invention, solder leaching is minimized without the use of more expensive platinum or palladium by coating first end termination 36 with nickel termination 30 so as to avoid silver leaching when the varistor device is soldered to a board.

[0027] A method of providing nickel barrier end terminations for a zinc oxide semiconductor device with exposed body surfaces and end terminal regions, in which the device is controllably reacted with a nickel plating solution only on an exposed end terminal region and thereafter provided with a final tin or tin-lead termination.

Claims

1. A method of making a semiconductor device, the body of the semiconductor device having an exposed zinc oxide surface and nickel end terminations, the method comprising the steps of providing a semiconductor body having electrically conductive plates interleaved with zinc oxide layers, providing a selected nickel plating solution for an intended method of nickel plating, and controllably contacting an end of the semiconductor body with the nickel plating solution in order to form a desirably thick nickel barrier cap over the end of the semiconductor body without forming a nickel barrier cap over the entire semiconductor body, in which the temperature of the nickel plating solution is uncontrolled and remains at approximately room temperature.
2. A method as claimed in claim 1, wherein the pH of the nickel plating solution is maintained between about 2 and about 6, and contact between the semiconductor body and the nickel plating solution is maintained for a period of approximately 10 to 120 minutes.
3. A method as claimed in claim 2, wherein contact between the semiconductor body and the nickel plating solution is maintained until the thickness of the nickel barrier cap is between approximately 1 and 3 μm .
4. A method as claimed in any of claims 1 to 3, characterized by the step of forming a solderable contact by partially immersing the nickel barrier cap in an acid solution comprising one or more of Alkyl-Tin, Alkyl-Tin-Lead, Tin-Lead sulphuric acid, or Tin sulphuric acid with a pH between about 3 to about 6 at room temperature, and the immersion of the nickel barrier cap in the acid solution is for a period of about 10 to about 120 minutes.
5. A method as claimed in claim 4, characterized by the application to the nickel barrier cap of a biasing current of approximately 0.3 to 2.0 A/dm², and the immersion of the nickel barrier cap in the acid solution continues until a solderable contact having a thickness of 3 to 6 μm is formed.
6. A method as claimed in any of claims 1 to 5, wherein

the nickel plating solution is a room temperature solution comprising one or more of nickel sulphate, dimethylamineborane, lactic acid, ammonium citrate, and ammonia, in which the zinc oxide layers have a resistivity in the range from about 10^{10} to about 10^{12} Ohms/cm².

7. A method as claimed in claim 6, including the further steps of applying a termination material comprising silver and glass frit onto the end of the semiconductor body,

firing the semiconductor body to mechanically bond the termination material with the end of the semiconductor body, and the termination material is essentially free of platinum and palladium, and the termination material is fired at a temperature between about 550 and 800°C.

8. A method as claimed in claim 7, wherein the nickel plating solution includes one or more of (i) nickel sulphate or nickel chloride, (ii) boric acid, (iii) a wetting agent, and (iv) a stress relieving agent at a temperature of about 50 to 70°C including the further step of applying a biasing current of about 0.3 to about 2.0 A/dm² during nickel plating, in which the biasing current is variably dependent on the area of the end of the semiconductor to be coated, and the immersion depth of the semiconductor body is controlled to thereby selectively control the distance that the barrier cap extends upwardly from the end of the semiconductor body.

9. A method as claimed in any of claims 1 to 8, wherein the controllable contact is by impregnated absorbent material.

10. A method of providing a semiconductor device having a body with an exposed zinc oxide surface and electrically conductive, solderable metal end terminations, the method comprising the steps of providing a semiconductor body having electrically conductive plates interleaved with zinc oxide layers, applying a termination material comprising silver and glass frit onto opposing ends of the semiconductor body, mechanically bonding the termination material to the ends of the semiconductor body by firing, providing at a temperature of about 50 to 70°C a nickel plating solution comprising one or more of (i) nickel sulphate or nickel chloride, (ii) boric acid, (iii) a wetting agent, and (iv) a stress relieving agent, coating a silver terminated end of the semiconductor body by selectively partially immersing the end of the semiconductor body in the nickel plating solution for a period of about 15 to about 120 minutes while applying a biasing current of about 0.3 to 2.0 A/dm² whereby to form a desirably thick nickel barrier cap in contact with the silver terminated end which extends a selected distance up the body of

the semiconductor device; providing a final termination solution of one or more of alkyl-tin, alkyl-tin-lead, tin-sulfuric acid or tin-lead-sulfuric acid, having a pH from about 3 to about 6 and an uncontrolled temperature; and forming a desirably thick, electrically conductive, solderable contact end termination over the nickel barrier cap by selectively partially immersing the end of the semiconductor body into the final termination solution for a period of about 10 to about 120 minutes while applying a biasing current of about 0.3 to about 2.0 A/dm², in which the pH of the nickel plating solution is maintained between about 2 and about 6.

11. A method as claimed in 10, wherein the silver termination material is provided free of platinum and palladium and is fired onto the semiconductor body at a temperature between about 550 and about 800°C, and the partial immersion of the semiconductor body in the nickel plating solution is continued until the thickness of the nickel coating is between about 1 and about 3 μm.

12. A method as claimed in claims 10 or 11, wherein the solderable contact is about 3 to about 6 μm thick, with the distance that the barrier cap extends from the end of the semiconductor body is controlled by controlling the immersion depth, and the biasing current is varied as a function of the area of semiconductor to be coated.

13. A method of providing metal end terminations to a semiconductor device without the use of a plating resist comprising the steps of providing a semiconductor body having a zinc oxide exterior with electrically conductive elements interleaved between ceramic layers consisting principally of zinc oxide, providing a nickel plating solution comprising one or more of nickel sulphate, dimethylamineborane, lactic acid, ammonium citrate, and ammonia at room temperature, positioning one end of the semiconductor body a selectable distance into the nickel plating solution for a period of about 15 to about 120 minutes to thereby form a desirably thick nickel barrier cap over the end of the semiconductor body, providing a metal termination solution of either: alkyl-tin, alkyl-tin-lead, tin-sulfuric acid, or tin-lead-sulfuric acid, having a pH between about 3 to about 6; forming a metal termination over the nickel barrier cap by partially immersing an end of the semiconductor body into the metal termination solution for a period of about 10 to about 120 minutes while applying biasing current of about 0.3 to about 2.0 A/dm², the pH of the nickel plating solution is maintained between about 2 and about 6, the semiconductor body is immersed in the nickel plating solution until the thickness of the nickel coating is between about 1 and about 3 μm and the barrier cap

is coated with a solderable contact 3 to 6 μm thick.

14. A method as claimed in claim 13, including the step of providing a silver fired termination on the end of the semiconductor body prior to partial immersion in the nickel plating solution, in which the zinc oxide resistivity is between about 10^{10} to about 10^{12} Ohms/cm². 5
15. A method as claimed in any of claims 1 to 14, wherein the semiconductor body is maintained in contact with absorbant material for a period sufficient to form a nickel barrier thickness of about 1 to about 3 μm , and the further step of moving the semiconductor body relative to the absorbent material. 10 15
16. A varistor comprising a body of interleaved resistive plates and zinc oxide layers having an external surface of zinc oxide free of any passivation material, nickel barrier caps on opposing ends of the body, the nickel barrier caps terminating with naturally formed edges, including a silver barrier between the body and the nickel barrier, in which the nickel barrier cap is between about 1 and about 3 μm thick. 20 25

30

35

40

45

50

55

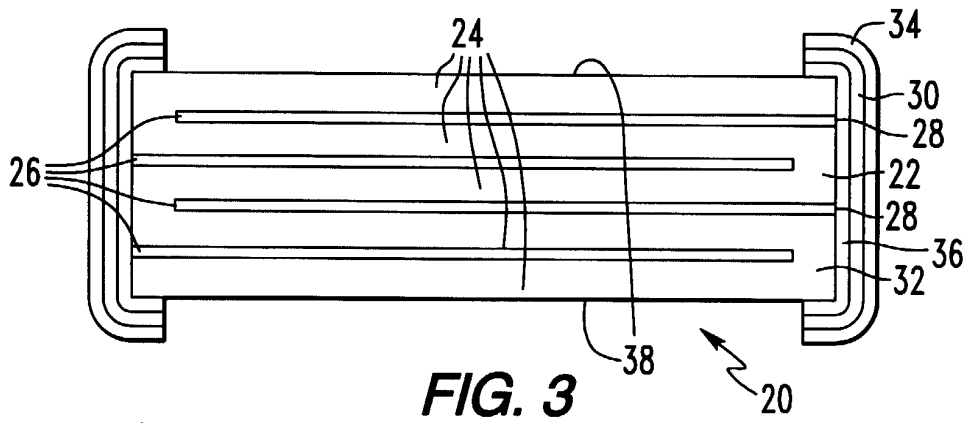
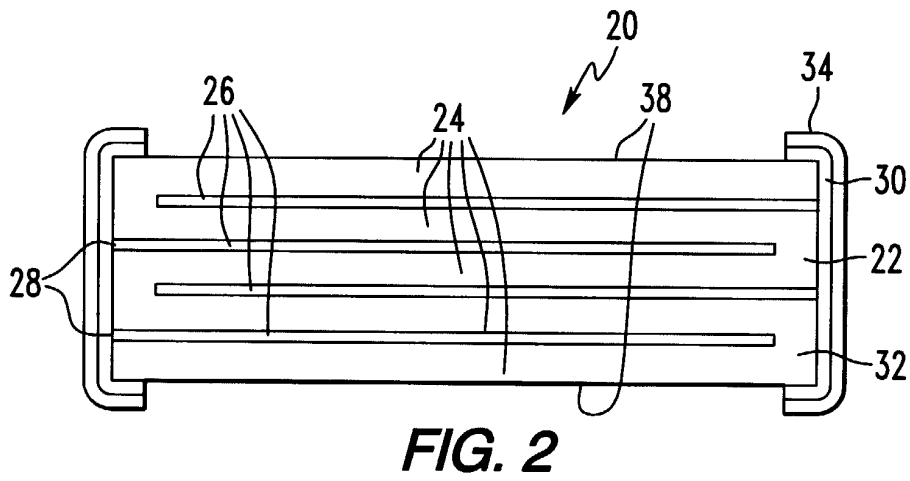
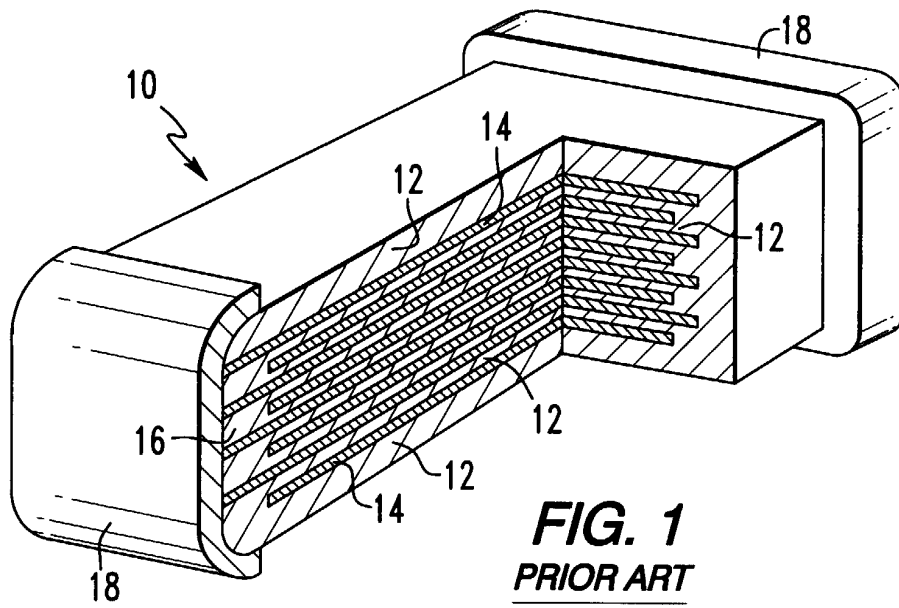



European Patent
Office

EUROPEAN SEARCH REPORT

Application Number
EP 98 30 5676

DOCUMENTS CONSIDERED TO BE RELEVANT			
Category	Citation of document with indication, where appropriate, of relevant passages	Relevant to claim	CLASSIFICATION OF THE APPLICATION (Int.Cl.6)
X	PATENT ABSTRACTS OF JAPAN vol. 098, no. 011, 30 September 1998 -& JP 10 172807 A (MITSUBISHI MATERIALS CORP), 26 June 1998 * abstract *	16	H01C7/102 H01C1/14 H01C17/28
Y	---	1-3,13	
Y	PATENT ABSTRACTS OF JAPAN vol. 006, no. 194 (E-134), 2 October 1982 -& JP 57 105962 A (SUGITA KURANOBU), 1 July 1982 * abstract *	1-3,13	
A	---		
A	EP 0 092 971 A (RICHARDSON CHEMICAL CO ;IBM (US)) 2 November 1983 * page 16, line 31 - page 17, line 7 * * page 18, line 25 - page 19, line 4 *	1-4,6,7, 10,13,16	
A	EP 0 716 429 A (HARRIS CORP) 12 June 1996 * column 3, line 53 - column 4, line 6 *	1,2,4,6, 7,10,13, 16	TECHNICAL FIELDS SEARCHED (Int.Cl.6)
A	PATENT ABSTRACTS OF JAPAN vol. 098, no. 001, 30 January 1998 -& JP 09 246017 A (TDK CORP), 19 September 1997 * abstract *	1,4,6,7, 10,13,16	H01C
A	---		
A	DE 196 34 488 A (SIEMENS MATSUSHITA COMPONENTS) 5 March 1998 -----	1,4,6,7, 10,13,16	
The present search report has been drawn up for all claims			
Place of search THE HAGUE		Date of completion of the search 2 December 1998	Examiner Wirner, C
CATEGORY OF CITED DOCUMENTS X : particularly relevant if taken alone Y : particularly relevant if combined with another document of the same category A : technological background O : non-written disclosure P : intermediate document		T : theory or principle underlying the invention E : earlier patent document, but published on, or after the filing date D : document cited in the application L : document cited for other reasons ----- & : member of the same patent family, corresponding document	

EPO FORM 1503 03.82 (P04C01)

**ANNEX TO THE EUROPEAN SEARCH REPORT
ON EUROPEAN PATENT APPLICATION NO.**

EP 98 30 5676

This annex lists the patent family members relating to the patent documents cited in the above-mentioned European search report.
The members are as contained in the European Patent Office EDP file on
The European Patent Office is in no way liable for these particulars which are merely given for the purpose of information.

02-12-1998

Patent document cited in search report	Publication date	Patent family member(s)	Publication date
EP 0092971 A	02-11-1983	CA 1207464 A	08-07-1986
		JP 1720900 C	24-12-1992
		JP 3067356 B	22-10-1991
		JP 58202595 A	25-11-1983
		US 5403650 A	04-04-1995
		US 5565235 A	15-10-1996
EP 0716429 A	12-06-1996	US 5614074 A	25-03-1997
		JP 8227802 A	03-09-1996
		US 5757263 A	26-05-1998
DE 19634488 A	05-03-1998	NONE	