

P. L. ROEDIGER.
 MACHINE FOR FORMING LOCKING DEVICES FOR JAR CLOSURES.
 APPLICATION FILED MAY 25, 1909.

985,452.

Patented Feb. 28, 1911.

2 SHEETS—SHEET 1.

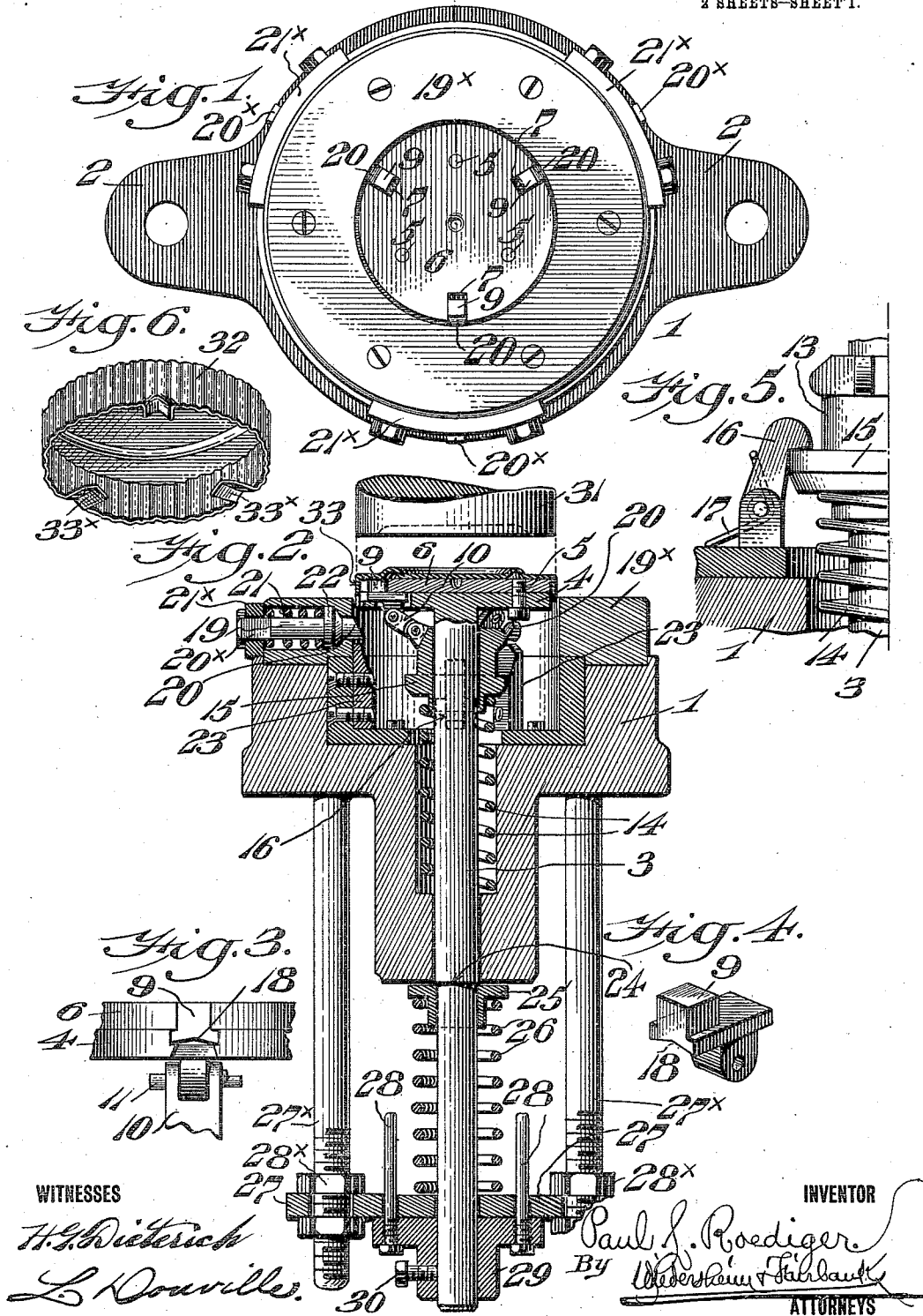

WITNESSES

H. G. Dietrich
L. Douville

INVENTOR

Paul L. Roediger
 By *Widerstam & Fairbank*
 ATTORNEYS

P. L. ROEDIGER.
 MACHINE FOR FORMING LOCKING DEVICES FOR JAR CLOSURES.
 APPLICATION FILED MAY 25, 1909.

985,452.

Patented Feb. 28, 1911.

2 SHEETS—SHEET 2.

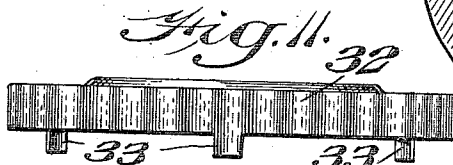
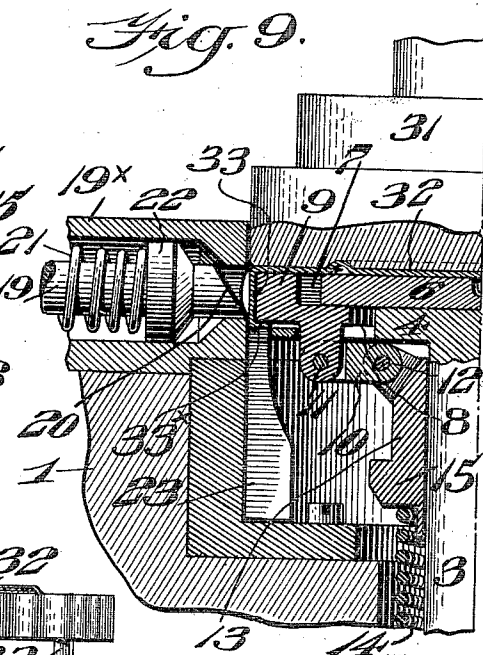
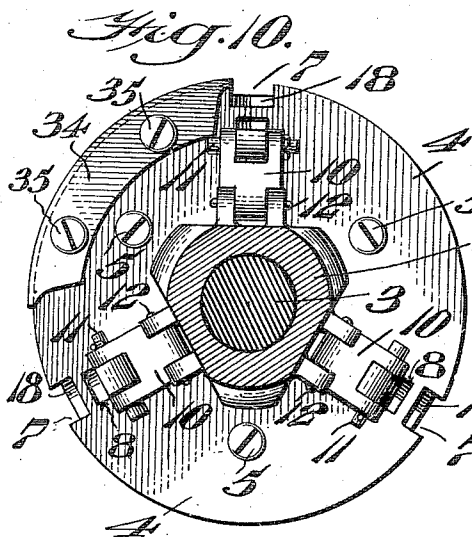
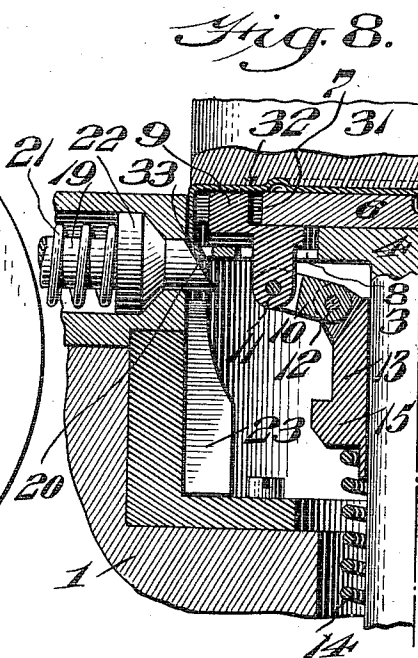
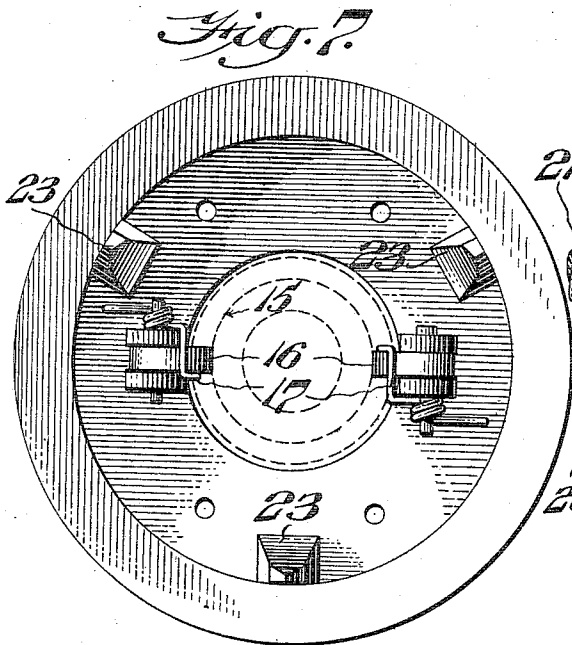

WITNESSES

H. G. Dietrich
L. Rowville

BY

Paul L. Roediger
Niederstein & Faulstich
 ATTORNEYS

UNITED STATES PATENT OFFICE.

PAUL L. ROEDIGER, OF PLEASANTVILLE, NEW JERSEY.

MACHINE FOR FORMING LOCKING DEVICES FOR JAR-CLOSURES.

985,452.

Specification of Letters Patent. Patented Feb. 28, 1911.

Application filed May 25, 1909. Serial No. 498,260.

To all whom it may concern:

Be it known that I, PAUL L. ROEDIGER, a citizen of the United States, residing in Pleasantville, county of Atlantic, State of New Jersey, have invented a new and useful Machine for Forming Locking Devices for Jar-Closures, of which the following is a specification.

This invention relates to a machine for use in the manufacture of bottle or jar caps and the like and has for an object to provide simple and efficient means of forming a locking lug or device for maintaining the cap in position upon the receptacle to prevent displacement or removal thereof, except when desired, the work being done accurately and quickly and the cap itself not damaged nor altered in appearance.

Figure 1 represents a top plan of a mechanism embodying my invention. Fig. 2 represents a sectional elevation of the same. Figs. 3 and 4 represent details of the die construction. Fig. 5 represents a detail of a stop mechanism. Fig. 6 represents a perspective view of a finished jar cap, showing the locking devices formed thereon. Fig. 7 represents a plan with the cap holder removed. Fig. 8 represents an enlarged section of a portion of Fig. 2 showing the position of the parts in the first step in the formation of the locking lug. Fig. 9 represents a section similar to Fig. 8, showing the position of the parts at the end of the lug forming stroke. Fig. 10 represents a bottom plan of a portion of the cap supporting mechanism. Fig. 11 represents a side elevation of a cap as delivered to my novel mechanism.

Similar numerals of reference indicate corresponding parts in the figures.

Referring to the drawings:—1 designates a suitable head having apertured lugs 2 formed integral therewith, whereby the said head may be secured to the bed plate of a suitable machine, such as a punch press or the like. The head 1 is suitably bored and counterbored for the reception of cooperating parts of the mechanism, wherein 3 designates a spindle mounted for sliding movement in the head 1 and having preferably integral with one end a plate 4, to which is suitably secured by bolts 5 or the like, a cap holder 6. This holder 6 is shaped to conform to the cap which is to be carried there-
55 by and at suitable intervals is provided with

openings 7 representing the number of locking lugs or devices which it is desired to form upon the cap. In alinement with each opening 7 is a slot 8, formed in the plate 4 and designed to form an operating space for a die 9, here shown as projecting into the opening 7 of the holder 6. It will be noted that the die 9 has a sliding fit with the opening 7 so that the same may be moved from one position to another to effect a successful operation of the mechanism. The movement of each die, as here shown, is controlled by a link 10 secured thereto by a pivot pin 12 which is secured to a hub 13, slidingly mounted upon the spindle 3. As here shown, the normal position of this hub 13 is such as to maintain the respective dies 9 in position shown in Fig. 2. The control of the movements of the dies is accomplished in the present instance by means of a spring 14 located between the hub 13 and head 1 and normally tending to force the hub toward the plate 4 to move the dies outward radially of the said plate 4 the movement being normally restrained by devices now to be described.

15 designates a flange formed on the hub 13 and serving as a means to engage a plurality of stops 16 suitably disposed with relation thereto and in the present instance pivotally mounted upon the head 1 and held in the path of movement of the flange 15 by means of springs 17 or equivalent devices. It will be apparent that an upward movement of the hub 13 under pressure of the spring 14 is limited by the stops 16, which are pressed outwardly and prevent the flange 15 from further movement and thus control the movement of the dies 9. It will be noted that each die in the present instance has a V-shaped portion 18 for forming the lug of this predetermined shape, although of course it will be understood that the dies may be of any shape desired to produce any other form of lug, as occasion may demand.
19* designates a suitable ring secured to the head 1 and having plungers 19 slidingly mounted therein in alinement with each opening 7 of the holder 6 and adapted to cooperate with a cap in a certain portion of its movement, as will presently appear. Each of these plungers 19 is preferably provided with a beveled end 20, for a purpose to be presently described. In order to maintain the beveled end 20 of the plungers 9

in correct position, each plunger is provided preferably with a square portion 20^x fitting and slidingly mounted in a plate 21^x, as will readily appear.

5 21 designates a spring preferably of relatively stiff material, abutting a collar 22 of each plunger, whereby the said plungers are normally held projecting into the path of movement of the material carried by the
10 plate 4. Adjacent each plunger, in alinement therewith, and secured in any well known manner to the head 1, is a die 23 having an end shaped to register with the portion 18 of the die 9, the function of which is
15 to receive the partially formed lug of the cap and complete the last step in the formation of the lugs. In order to hold the spindle 3 with its plate 4 in position to receive the cap, I preferably provide the spindle 3
20 with a shoulder 24, contacting with which is a follower 25 subjected to the pressure of a spring 26 abutting a base plate 27, which latter is preferably adjustably mounted in order to provide means for regulating the
25 tension of the spring 26. In the present instance rods 27^x are formed integral with or secured to the head 1 and are suitably threaded to receive locking nuts 28^x adapted to engage the plate 27 and hold the same as
30 desired. It will of course be understood that the plate 27 is suitably apertured for sliding movement of the said rods 27^x. It will be clear that by this adjustable feature the tension of the spring 26 may be varied to
35 bring about a quick return of the dies 9 and the cooperating parts to normal position after a stroke of the operating mechanism. This plate 27 is suitably apertured for guide rods 28 secured to a sleeve 29, which latter is
40 fixed to the spindle 3 by means of a set screw 30 or the like. The function of the guide rods 28 will be apparent since they are intended to prevent rotation of the spindle relative to the other parts of the construction and thus always maintain the dies 9,
45 plunger 19 and dies 23 in alinement.

31 designates a portion of the press plunger which is operated in any suitable manner to engage the cap material by the holder
50 6 and performing the pressing operation, which is an essential part of the operation.

Referring to Fig. 11, a cap 32 is shown which in the present instance is the particular type upon which this embodiment of my
55 invention is adapted to operate, the said cap in a previous operation having been formed with downwardly projecting lugs 33. 34 designates a stop, in the present instance suitably secured by screws 35 or the like to
60 the bottom of the plate 4 and located adjacent one of the openings 7, whereby the cap 32 is always accurately placed upon the holder 6 with the lugs properly positioned. Of course it will be understood that a number
65 of stops similar to the stop 34 may be

employed but as one operates efficiently for the purpose, I have not deemed it necessary to disclose a plurality.

In the operation of the device this cap 32 is placed upon the holder 6 with the lugs 33
70 fitting into the openings 7, whereupon the press plunger 31 is brought down into contact with the cap and thus overcomes the pressure of the spring 26 and lowers the spindle with its cooperating parts. This
75 movement brings the lugs 33 into engagement with the beveled ends 20 of the plungers 19 and as the springs 21 are under a tension preferably greater than the strength of the material of which the lugs 33 are composed, the said lugs 33 are bent as shown in
80 Fig. 8 without producing a movement of the plungers 19. As soon as this bending occurs the plate 4 has been lowered sufficiently to overcome the pressure of the spring 21
85 and the plungers 19 are therefore forced back and the bent ends of the lugs 33 are brought into contact with the die 23. During this movement of the table 4, the flange 15 has been removed from the stops 16 and the
90 spring 14 operates upon the hub 13 to force the dies 9 outwardly back of the partially turned lug 33 in order to cooperate with the die 23 when the plunger presses the lugs upon the said dies. In this manner the lugs
95 33 are formed with a bend 33^x as will be seen in Fig. 6, whereby the contour of the cap remains unchanged and the lugs are accurately shaped and finished for the purpose intended. As soon as the plunger 31 is re-
100 tracted the spring 26 returns the plate 4 and the holder 6 to its former position, during which movement the flange 15 of the hub 13 strikes the spring pressed stops 16 and is held so as to withdraw the dies 9 inwardly a
105 sufficient distance to be out of the path of movement of the turned in lugs 33 to permit removal of the cap. In this manner the cap may be readily taken from the holder 6 and as soon as a new cap is placed thereon the
110 operation may be repeated. It will now be apparent that I have devised a lock forming means for use in connection with bottle caps, simple in construction, efficient in operation and effective for the purpose intended and
115 whereby the danger of damage to the cap itself is reduced to a minimum and the locking lugs or devices may be shaped as desired.

It will now be apparent that I have devised a novel and useful construction which
120 embodies the features of advantage enumerated as desirable in the statement of the invention and the above description and while I have in the present instance shown and described the preferred embodiment
125 thereof which has been found in practice to give satisfactory and reliable results, it is to be understood that the same is susceptible of modification in various particulars without departing from the spirit or scope
130

of the invention or sacrificing any of its advantages.

Having thus described my invention, what I claim as new and desire to secure by Letters Patent, is:—

1. In a device of the character described, a head, dies within the same, a spindle slidingly mounted in said head, a cap-supporting device carried by said spindle, and means embodying spring-actuated plungers to bend a lug on the cap.

2. In a device of the character described, a head, dies within the same, a spindle slidingly mounted in said head, a cap-supporting device carried by said spindle, a press plunger for cooperation with said cap-supporting device, and means embodying independently movable sliding plungers constructed to bend a plurality of lugs on the cap.

3. In a device of the character described, a head, dies within the same, a spindle slidingly mounted in said head, a cap-supporting device carried by said spindle and adapted to receive a cap having a lug thereon, a plunger for cooperation with and moving said cap-supporting device and independently movable sliding means constructed to bend said lug to a predetermined position.

4. In a device of the character described, a head, dies within the same, a spindle slidingly mounted on said head, a cap-supporting device carried by said spindle and adapted to receive a cap having a plurality of lugs thereon, a plunger movable with relation to said supporting device and constructed to move the same in the direction of the spindle, and means to initially bend said lugs.

5. In a device of the character described, a head, a spindle slidingly mounted on said head, a cap-supporting device carried by said spindle and adapted to receive a cap having a lug thereon, a plunger for cooperation with and moving said cap-supporting device, relatively movable means to initially bend said lug, and relatively fixed means within said head to further bend said lug.

6. In a device of the character described, a head, a spindle slidingly mounted on said head, a cap-supporting device carried by said spindle and adapted to receive a cap having a plurality of lugs thereon, a plunger movable with relation to said supporting device and constructed to move the same in the direction of the spindle, means to initially bend said lugs, and relatively fixed means within said head to further bend said lugs.

7. In a device of the character described, a head, a yieldingly supported spindle slidingly mounted therein, a cap-supporting de-

vice carried by said spindle and having a plurality of openings therein, a die slidingly mounted in each opening, a plunger movable with relation to and adapted for cooperation with said cap-supporting device to depress the same, and means for shifting said dies at a predetermined time.

8. In a device of the character described, a head, a spindle slidingly mounted therein, a cap-supporting device carried by said spindle and having a plurality of openings therein, a die slidingly mounted in each opening, a plunger for cooperation with said cap-supporting device to depress the same, means for shifting said dies at a predetermined time, and plungers slidingly mounted in the head substantially parallel with said dies.

9. In a device of the character described, a head, a spindle slidingly mounted therein, a cap-supporting device carried by said spindle having a plurality of openings therein, a die slidingly mounted in each opening, a hub operatively connected to said dies, a plunger for cooperation with said supporting device to actuate the same, a spring normally under tension to shift said dies in one direction, and slidingly mounted plungers carried by said head.

10. In a device of the character described, a head, a spindle slidingly mounted therein, a cap-supporting device carried by said spindle having a plurality of openings therein, a die slidingly mounted in each opening, a hub operatively connected to said dies, a plunger for cooperation with said supporting device to actuate the same, a spring normally under tension to shift said dies in one direction, slidingly mounted plungers carried by said head, and dies carried by said head adjacent each of said plungers.

11. In a device of the character described, a head, a yieldingly supported cap-supporting device with plungers, dies within said head, and radially slidable plungers carried by the head for cooperation with said dies.

12. In a device of the character described, a yieldingly mounted cap-supporting device, a head within which it is received, a cooperating plunger for moving the cap supporting device, slidingly mounted means for initially bending lugs on a cap supported by said cap-supporting device, and relatively fixed means carried by the head for further bending said lugs to a predetermined position by the continued motion of said cap-supporting device.

PAUL L. ROEDIGER.

Witnesses:

ROBERT M. BARR,
C. D. McVAY.