

C. R. DAELLENBACH.
AIR BRAKE.

No. 415,162.

Patented Nov. 12, 1889.

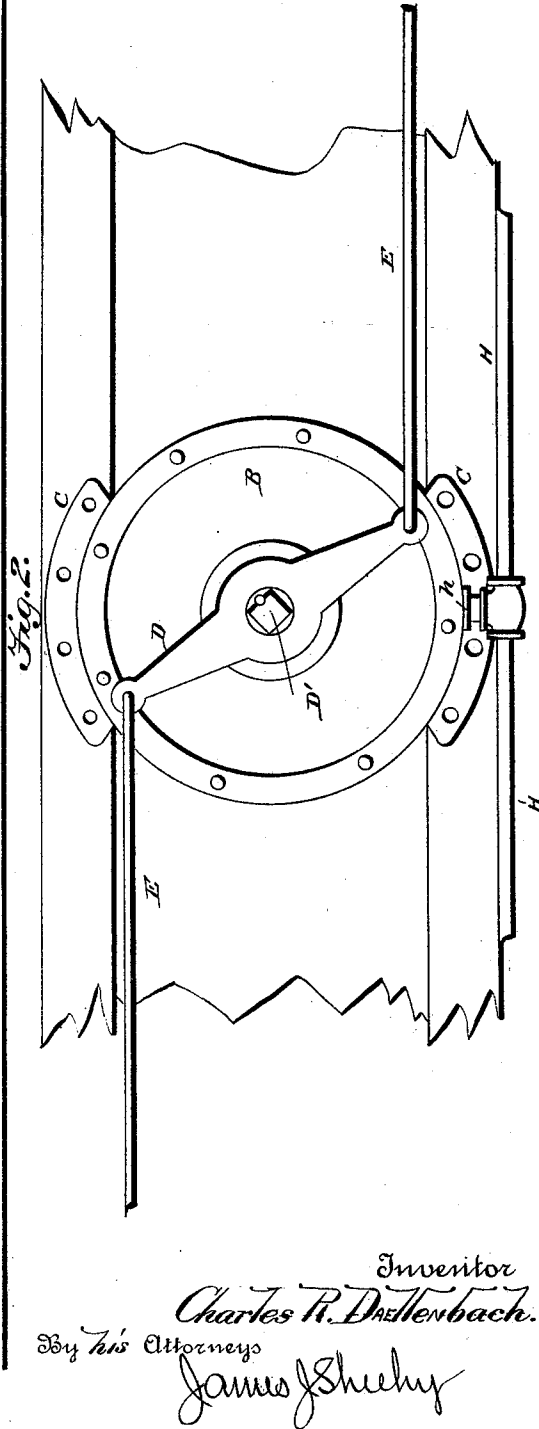
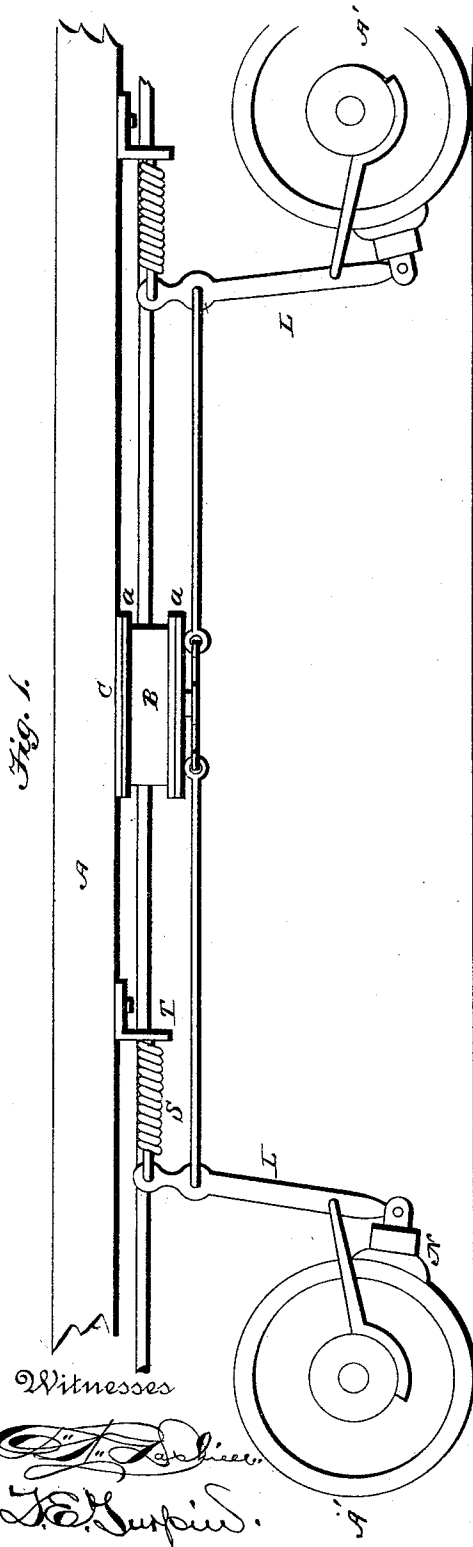

C. R. DAELLENBACH.
AIR BRAKE.

No. 415,162.

Patented Nov. 12, 1889.

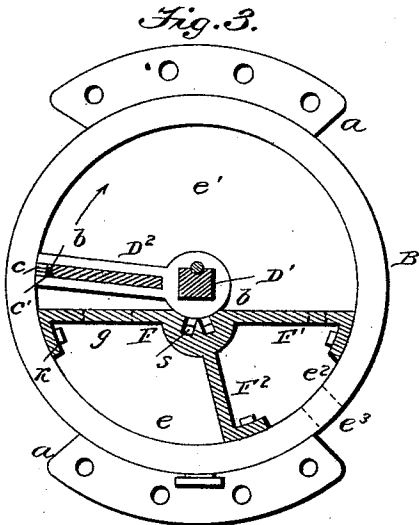

Fig. 3.

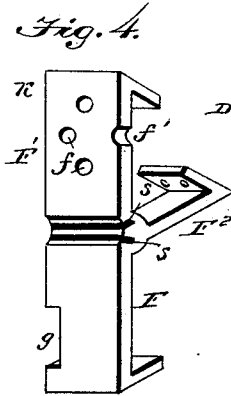

Fig. 4.

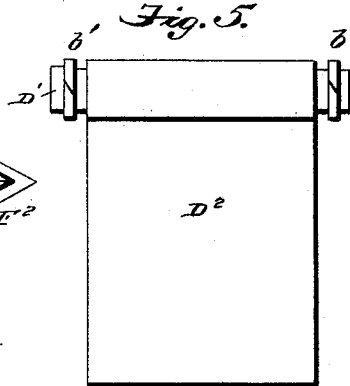

Fig. 5.

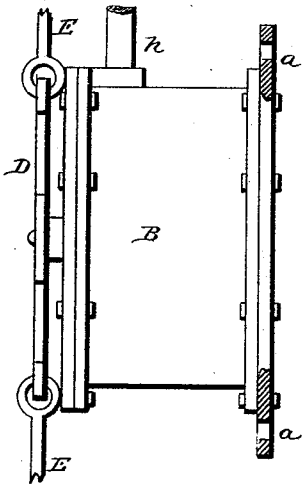

Fig. 6.

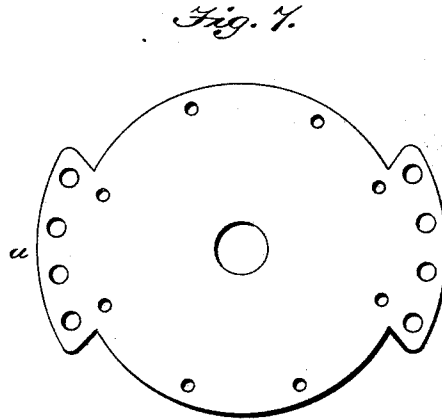

Fig. 7.

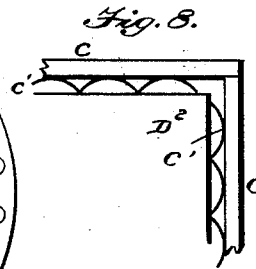

Fig. 8.

Witnesses

J. D. Schieffelin
J. D. Suskind

Inventor

Charles R. Daellenbach

By his Attorneys

James J. Sheehy

UNITED STATES PATENT OFFICE.

CHARLES R. DAELLENBACH, OF ALLEGHENY, PENNSYLVANIA.

AIR-BRAKE.

SPECIFICATION forming part of Letters Patent No. 415,162, dated November 12, 1889.

Application filed May 28, 1889. Serial No. 312,427. (No model.)

To all whom it may concern:

Be it known that I, CHARLES R. DAELLENBACH, a citizen of the United States, residing at Allegheny, in the county of Allegheny and State of Pennsylvania, have invented certain new and useful Improvements in Air-Brakes; and I do declare the following to be a full, clear, and exact description of the invention, such as will enable others skilled in the art to which it appertains to make and use the same.

My invention relates to certain novel improvements in air-brakes for railway-cars, which improvements will be fully understood from the following description and claims, taken in connection with the annexed drawings, in which—

Figure 1 is a side elevation showing my improved air-brake applied to a portion of a railway-car, the couplings for the air-line pipe being omitted. Fig. 2 is a bottom of part of the bed of a car, the brake-drum, its lever and brake-rods, and a portion of the air-line pipe. Fig. 3 is a plan view of the brake-drum with one of the heads removed to show the vibrating piston and the three air-chambers therein. Fig. 4 is a perspective view of the three-limbed frame detached from the brake-drum. Fig. 5 is a face view of the vibrating piston. Fig. 6 is a side view, partly in section, of the brake-drum. Fig. 7 is a face view of the upper flanged drum-head. Fig. 8 is a view in detail of the piston and its spring-actuated packing-strips.

Similar letters of reference indicate corresponding parts in the several figures.

Referring to the annexed drawings by letter, A designates part of the bed or sill-beams of a railway-car, and A' the truck-wheels thereof. As my invention is applicable to railway cars and locomotives as at present constructed, it is not necessary to particularly describe these structures.

B designates a brake-drum, which I have represented in Figs. 1 and 2 arranged with its axis vertical; but I may arrange this drum with its axis horizontal. This drum B is rigidly secured to the car-bed by means of bolts passing through the flanges *a a* of its upper head, and also through bracket-sectors C C.

D' is a central vertical shaft journaled in

the heads of the said drum and provided with packing-rings *b' b'*. On this shaft is suitably secured a flat vibrating piston D², inside of the drum, and a double-armed lever D outside of this drum. The piston D² has its three edges deeply grooved, and in the grooves are applied springs *c'* and packing-strips *c*, as shown in Figs. 3 and 8. This will prevent leakage of air.

K designates what I denominate a "partition-spider," which is composed of three limbs F F' F², each secured by its flanged outer end rigidly to the inner face of the drum B, as clearly shown in Fig. 3. This spider subdivides the interior of the said drum into three chambers *e e' e²* of different sizes. The compressed air forced into the line pipes or hose H enters the chamber *e* through a T-union *h*, thence passes through an aperture *g* into the chamber *e'* on one side of the piston D², forcing this piston in the direction indicated by the arrow on Fig. 3 and applying the brakes hereinafter explained. Air which is on the opposite side of the said piston D² is forced through apertures *f f'* into the chamber *e²*, and from thence is expelled from the drum B through the aperture *e²*. The aperture *f'* is a notch made in the bottom of the limb F' of the spider K, and is designed to allow any water or dirt to be forced out of the piston-chamber *e'*. This shaft is seated in a groove in the central enlarged portion at the junction of the three branches of the spider K, and suitable packing *s* is fitted into grooves made into the said enlargement, so as to impinge against the surface of the said piston-shaft.

To the ends of the lever D above referred to the brake-rods E E are suitably linked. These rods are also linked to brake-levers pivoted at their lower ends to brake-bars N and at their upper ends to recoil-springs S, attached to brackets T, which are secured to the car-bed A, substantially as shown in Fig. 1.

It will be observed that when compressed air is admitted into the chambers *e e'* the piston will be forcibly moved in the direction indicated by the arrow on Fig. 3, above referred to, and the brakes will be applied, and that when the pressure of air is cut off the springs S S will react to return the said piston

and the brakes to their normal positions, ready for another application of the brakes when necessary.

Having described my invention, what I claim is—

- 5 1. In an air-brake device, the combination, with brake-shoe levers and a double lever D, of a drum provided with a spider-partition K, perforated as described, and a vibrating
10 piston having its edges packed, substantially as described.
- 15 2. The combination of the brake-drum, the three-limbed partition subdividing this drum into three chambers $e e' e^2$, the air inlet and outlet apertures, and the vibrating piston provided with edge packing and a hub or shaft packing, substantially as specified.

3. The combination, with the brake-drum, of the three-limbed partition subdividing said drum into the chambers $e e' e^2$, the air inlet and outlet apertures, the piston D², the lever connected to brakes, with one or more recoil-springs adapted to return said piston and brakes to normal positions when the pressure of air is cut off from the interior of the drum on one side of the piston, substantially as specified.

In testimony whereof I affix my signature in presence of two witnesses.

CHAS. R. DAELLENBACH.

Witnesses:

JOHN SENBERT,
L. BLATTNER.