



- (51) International Patent Classification:
G01T 1/36 (2006.01)
- (21) International Application Number:
PCT/US2011/067557
- (22) International Filing Date:
28 December 2011 (28.12.2011)
- (25) Filing Language: English
- (26) Publication Language: English
- (30) Priority Data:
61/427,687 28 December 2010 (28.12.2010) US
- (71) Applicant (for all designated States except US): **QUINTELL OF OHIO, LLC** [US/US]; 7659 Cairn Lane, Gates Mills, OH 44040 (US).
- (72) Inventors; and
- (75) Inventors/Applicants (for US only): **MANISCALCO, James** [US/US]; 55885 Turnberry Way, LaQuinta, CA 92253 (US). **CHAPMAN, Mac, Clements** [US/US]; 6847 Faircove Drive, Rancho Palos Verdes, CA 90275 (US). **SJODEN, Glenn** [US/US]; 901 Abernathy Road NE, Unit 5030, Sandy Springs, GA 30328 (US).
- (74) Agents: **SIMMONS, John, D.** et al.; Panitch Schwarze Belisario & Nadel LLP, One Commerce Square, Suite 2200, 2005 Market Street, Philadelphia, PA 19103 (US).

- (81) Designated States (unless otherwise indicated, for every kind of national protection available): AE, AG, AL, AM, AO, AT, AU, AZ, BA, BB, BG, BH, BR, BW, BY, BZ, CA, CH, CL, CN, CO, CR, CU, CZ, DE, DK, DM, DO, DZ, EC, EE, EG, ES, FI, GB, GD, GE, GH, GM, GT, HN, HR, HU, ID, IL, IN, IS, JP, KE, KG, KM, KN, KP, KR, KZ, LA, LC, LK, LR, LS, LT, LU, LY, MA, MD, ME, MG, MK, MN, MW, MX, MY, MZ, NA, NG, NI, NO, NZ, OM, PE, PG, PH, PL, PT, QA, RO, RS, RU, RW, SC, SD, SE, SG, SK, SL, SM, ST, SV, SY, TH, TJ, TM, TN, TR, TT, TZ, UA, UG, US, UZ, VC, VN, ZA, ZM, ZW.
- (84) Designated States (unless otherwise indicated, for every kind of regional protection available): ARIPO (BW, GH, GM, KE, LR, LS, MW, MZ, NA, RW, SD, SL, SZ, TZ, UG, ZM, ZW), Eurasian (AM, AZ, BY, KG, KZ, MD, RU, TJ, TM), European (AL, AT, BE, BG, CH, CY, CZ, DE, DK, EE, ES, FI, FR, GB, GR, HR, HU, IE, IS, IT, LT, LU, LV, MC, MK, MT, NL, NO, PL, PT, RO, RS, SE, SI, SK, SM, TR), OAPI (BF, BJ, CF, CG, CI, CM, GA, GN, GQ, GW, ML, MR, NE, SN, TD, TG).

- Published:**
- with international search report (Art. 21(3))
 - before the expiration of the time limit for amending the claims and to be republished in the event of receipt of amendments (Rule 48.2(h))

(54) Title: RADIOACTIVE ANOMALY DISCRIMINATION FROM SPECTRAL RATIOS

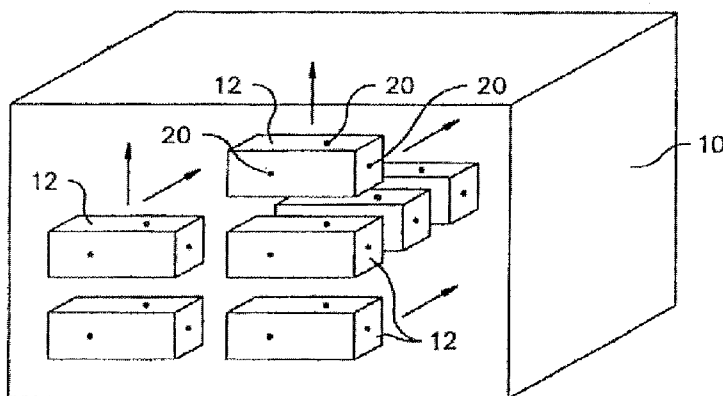

FIG. 10

(57) Abstract: A method for discriminating a radioactive anomaly from naturally occurring radioactive materials includes detecting a first number of gamma photons having energies in a first range of energy values within a predetermined period of time and detecting a second number of gamma photons having energies in a second range of energy values within the predetermined period of time. The method further includes determining, in a controller, a ratio of the first number of gamma photons having energies in the first range and the second number of gamma photons having energies in the second range, and determining that a radioactive anomaly is present when the ratio exceeds a threshold value.

WO 2012/092355 A1

TITLE OF THE INVENTION

Radioactive Anomaly Discrimination from Spectral Ratios

BACKGROUND OF THE INVENTION

5 An embodiment of the present invention relates generally to a method for discriminating radioactive anomalies from naturally occurring radioactive materials, and more particularly, to a method for discriminating highly enriched uranium (HEU) or other weapons grade radioactive materials from naturally occurring radioactive materials.

10 There is a growing concern that terrorists or others may at some time in the near future attempt to import into the United States or some other country radioactive or nuclear material which may then be used for the construction of a nuclear weapon for carrying out terrorist objectives. One way of shipping such radioactive or nuclear material is to hide the material among or within seemingly innocuous cargo or naturally occurring radioactive materials. For example, such nuclear material could be placed within a standard, sealed cargo container of the type typically employed for shipping cargo by sea, rail, air or by truck. The nuclear material
15 could be positioned within such a sealed cargo container, and may be shielded to avoid detection. Shielded HEU masked by naturally occurring radioactive materials is the most challenging detection problem.

It is therefore desirable to provide a reliable method of discriminating HEU or other radioactive materials of interest from naturally occurring radioactive materials.

20 SUMMARY OF THE INVENTION

An embodiment of the present invention is directed to a method for discriminating a radioactive anomaly from naturally occurring radioactive materials. The method includes detecting a first number of gamma photons having energies in a first range of energy values within a predetermined period of time and detecting a second number of gamma photons having
25 energies in a second range of energy values within the predetermined period of time. The method further includes determining, in a controller, a ratio of the first number of gamma photons having energies in the first range and the second number of gamma photons having energies in the second range, and determining that a radioactive anomaly is present when the ratio exceeds a threshold value.

Another embodiment of the present invention is directed to a method for determining the presence or absence of an expected radiation source. The method includes placing at least one radioactive material detection apparatus on an object containing the expected radiation source. The at least one radioactive material detection apparatus detects a first number of gamma photons emitted by the expected radiation source having energies in a first range of energy values within a predetermined period of time and a second number of gamma photons emitted by the expected radiation source having energies in a second range of energy values within the predetermined period of time. The method further includes determining, in a controller, a ratio of the first number of gamma photons having energies in the first range and the second number of gamma photons having energies in the second range, and comparing the determined ratio of the first and second numbers of gamma photons with an expected ratio of the first and second numbers of gamma photons for the expected radiation source.

Still another embodiment of the present invention is directed to a system for discriminating a radioactive anomaly from naturally occurring radioactive materials. The system includes at least one radioactive material detection apparatus configured to detect a first number of gamma photons having energies in a first range of energy values within a predetermined period of time and a second number of gamma photons having energies in a second range of energy values within the predetermined period of time. A controller configured to (i) determine a ratio of the first number of gamma photons having energies in the first range and the second number of gamma photons having energies in the second range, and (ii) compare the determined ratio with a threshold value.

BRIEF DESCRIPTION OF THE DRAWINGS

The foregoing summary, as well as the following detailed description of preferred embodiments of the invention, will be better understood when read in conjunction with the appended drawings. For the purpose of illustration, there is shown in the drawings an embodiment which is presently preferred. It should be understood, however, that the invention is not limited to the precise arrangements and instrumentalities shown.

Fig. 1 is a diagrammatic view of a hypothetical "air box" placed approximately 30 cm from a plutonium solid core canned in aluminum;

Fig. 2 is a diagrammatic view of the air box of Fig. 1 located in a shipping container;

Fig. 3 is a plot of gamma energy leakage from a 25 kg one year aged HEU solid sphere at the source box;

5 Fig. 4 is a plot of gamma energy leakage from a 25 kg, fifty year aged HEU solid sphere at the source box;

Fig. 5 is a plot of the behavior of 2.204 MeV gamma line emission over time for a 25 kg source;

Fig. 6 is a plot of the difference between gamma energy leakages of the one year and fifty year aged HEU;

10 Fig. 7 is a diagrammatic view of a 25 kg HEU shell source shielded with 1 cm of aluminum with a 30 cm radius source box;

Fig. 8 is a plot of gamma energy leakage for 25 kg one year HEU shell source shielded with 1 cm of Al at a 30 cm radius source box;

15 Fig. 9 is a plot of gamma energy leakage for 8 kg 22.5 year WGPu shell source shielded with 1 cm of Al at a 60 x 60 cm source plane centered 30 cm away;

Fig. 10 is a functional block diagram of a radioactive material detection system for use in a preferred embodiment of the present invention;

Fig. 11 is a schematic functional block diagram of a radioactive material detection apparatus for use in preferred embodiments of the present invention;

20 Fig. 12 is a flowchart of a first method in accordance with a preferred embodiment of the present invention; and

Fig. 13 is a flowchart of a second method in accordance with another preferred embodiment of the present invention.

DETAILED DESCRIPTION OF THE INVENTION

Certain terminology is used in the following description for convenience only and is not limiting. The words “right”, “left”, “lower”, and “upper” designate directions in the drawings to which reference is made. The words “inwardly” and “outwardly” refer to directions toward and away from, respectively, the geometric center of the device and designated parts thereof. The terminology includes the above-listed words, derivatives thereof, and words of similar import. Additionally, the words “a” and “an”, as used in the claims and in the corresponding portions of the specification, mean “at least one.”

High energy gamma rays from aged HEU are detectable with long dwell detectors (i.e., sensors positioned to capture gamma rays or other particles emitted by radioactive material over an extended period of time). It has been found that, for approximately one year old HEU, important gamma lines (mostly from protactinium-234 (Pa-234) and uranium-238 (U-238)) are located at 742, 766, 883, 926, 946 and 1001 kilo-electron volts (keV). By contrast, approximately fifty year old HEU, the most prominent gamma lines appear at 1120, 1238, 1764, and 2204 keV (mostly from bismuth-214 (Bi-214)).

As a result, the spectrum of detected gamma energies sensed at one or more detectors may be separated into sections and compared with one another to determine characteristic ratios. A particularly useful method for distinguishing HEU and naturally occurring radioactive material (NORM) compares the gamma counts in the range of 830-1060 keV with gamma counts in the range of 1060-3000 keV. For example, for one year old HEU the ratio of gamma source leakage in the 830-1060 keV range to gamma source leakage in the 1060-3000 keV range has been found to be approximately 3.40. For fifty year old HEU, this ratio drops significantly to approximately 0.84. Using NORM (aged approximately 2.2 billion years with 13.7 parts-per-million (ppm) U, 16.1 ppm thorium (Th) and 0.02 ppm potassium (K)), a ratio of approximately 0.43 has been found. There are NORM materials that have modified mixtures of isotopes from selected mineral deposits or other types of shipments. The numerator of the ratio is typically determined in part by the target radioactive material, and the denominator range defined by the type of NORM expected. A series of ratios can be designed and maximized and easily run sequentially to cover different possibilities. For example a ratio could be specifically designed for inspection of banana shipments which contain radioactive K isotopes.

It is understood by one skilled in the art that embodiments of the invention are not limited to a ratio comparing the above-described ranges. Each range may be limited to a single spectrum line. However, it is preferable that the selected ranges encompass a wide selection of gamma energies to lessen sensing time, improve count accuracies, and optimize performance for detector design and software. In addition, each selected range may be non-contiguous. For example, a first range may include counts for individually selected gamma energy lines.

These gamma source ratios can be used to identify a young HEU signal even in natural uranium and NORM bearing cargo. The use of gamma source ratios as a method for discriminating HEU from NORM has been confirmed through testing of an HEU surrogate source, as described below. The method can be implemented in a single radiation sensor or detector, but may also be implemented using two or more radiation sensors/detectors, which may be placed at various locations.

Shielded HEU masked by NORM in cargo is the most challenging detection problem. In a test example, young HEU (HEU purified less than 20 years ago) is discriminated from NORM by the ratio of gammas from Pa-234 and U-238 in the 830-1060 keV range to gammas from Bi-214 in the 1060-3000 keV range. As shown above, the ratio is lowest for NORM and eight times larger for one year old HEU. This approach has been validated in HEU surrogate source testing with cat litter. The natural uranium metal rods used in as a surrogate source are fifty years old +/- 10% (since separated at Savannah River National Laboratory). The ratios of the gamma spectral regions of interest (ROI) for HEU are shown in Table 1. The first three rows in Table 1 are the calculated gamma ratios for one year old HEU, fifty year old HEU, and 2.2 billion year old NORM. HEU and natural uranium metal rods will have the same expected ratios for the selected gamma ROIs. The fourth row is the experimental gamma ratio result obtained in the cat litter tests for the detector closest to the source. These results show a positive detection/discrimination of the fifty year old source because the gamma ratios obtained in the tests closely match the expected/calculated gamma ratios for fifty year old uranium material.

	Ratio (830-1060 keV)/(700-3000 keV)	Ratio (830-1060 keV)/(1060-3000 keV)
1 y HEU	0.55	3.40
50 y HEU	0.37	0.84
NORM	0.26	0.43
50 y Rods	0.35 +/- 0.04 (1-sigma)	0.91 +/- 0.09 (1-sigma)

TABLE 1 - Ratios of Gamma Spectral Regions of Interest (ROI) in HEU compared with cat litter shielded HEU testing

A similar case with 5 cm of lead added in front of the cat litter was also tested. In this test, the gamma ratio of (830-1060 keV) / (1060-3000 keV) was shown to be approximately 0.53 +/- 0.05. This gamma ratio lies in between the expected values for 50 year old HEU and NORM and could be a large enough variance from the expected gamma ratio to subject the container to additional inspection/analysis. More importantly, as uranium gets “younger” (less than 20 years since purification), the gamma ratio differences with NORM become much larger, as shown in Table 1.

Triangulation can also be used to discriminate a concentrated source of U-238 from dilute sources of NORM if the cargo with NORM is uniformly loaded. In this case, the number of counts for 830-1060 keV gammas from a concentrated HEU source will vary on the container detectors, with the closest detectors showing the most counts.

Several optimization studies were performed to assess how to approach capturing the detailed gamma and neutron signatures from the various sources to be considered to the greatest extent possible. While there are many resources available, the most comprehensive source terms that distinctly account for decay and all radiation from daughter nuclides as a function of energy can be generated using the Oak Ridge National Laboratory SCALE6 code system. Initial gamma calculations for the HEU and weapons grade plutonium (WG Pu) considered high resolution 1 keV binning and material age, where “age” in this context refers to time passing for the material as a final product since laboratory refinement and separation.

For HEU, one year old and fifty year old materials were utilized as test samples; “freshly” separated one year old material and “aged” fifty year old material differ in total activity from “nature aged” uranium in NORM. The primary effect is due to in growth of decay

daughters, examples of which include Pa-234, Pa-234m, and Bi-214 isotopes. Aged material is easier to detect than freshly purified material, and this will be discussed later.

For WGPu, 22.5 year old materials were utilized as test samples, since the average age of Pu typically falls between twenty and twenty-five years.

5 Intrinsic sources were generated for: 25 kg of 90% HEU (U-234 0.83%, U-235 90.00%, U-236 0.66%, U-238 8.50%); and 8 kg of WGPu (Pu-238 0.02%, Pu-239 93.279%, Pu-240 5.911%, Pu-241 0.200%, Pu-242 0.028%, Am-241 0.256%).

10 The X-Y plot in Fig. 1 depicts one hypothetical “air box” placed approximately 30 cm from the Pu solid core canned in aluminum (Al). This is one of many large MCNP5 models (X-Z Plot) used to analyze the scenarios considered, located inside a shipping container, as shown in Fig. 2. All dimensions are in centimeters.

15 Several source and cargo shielding scenarios were considered. HEU is the most challenging special nuclear material (SNM) material to detect since the predominant 186 keV gamma radiation from U-235 is easily shielded. Special attention was paid to gamma energies greater than 1 MeV with excellent shielding penetration potential under “long dwell” counting scenarios. The top 20 intrinsic gammas at energies greater than 1 MeV are listed in Table 2 for WGPu (8 kg, aged 22.5 years), natural uranium (NatU) (1.7 kg, aged 50 years), and HEU (25 kg, aged 50 years) sources.

Top Pu gammas		>1 MeV	Top NatU (L-heu) gammas		>1 MeV	Top HEU gammas		>1 MeV
MeV	Prob	gam/s	MeV	Prob	gam/s	MeV	Prob	gam/s
1.249	5.901E-08	251700.000	1.000	5.678E-03	61780.000	1.000	8.325E-06	78050.451
1.250	5.897E-08	251500.000	1.001	5.672E-03	61720.000	1.001	8.316E-06	77969.818
1.749	2.839E-08	121100.000	1.738	2.731E-04	2972.000	1.764	4.023E-06	37720.103
1.750	2.839E-08	121100.000	1.831	2.154E-04	2344.000	1.120	3.833E-06	35939.623
1.750	2.839E-08	121100.000	1.831	2.154E-04	2344.000	1.120	3.833E-06	35939.623
1.750	2.839E-08	121100.000	1.831	2.154E-04	2344.000	1.120	3.833E-06	35939.623
2.249	1.624E-08	69250.000	1.510	1.751E-04	1905.000	1.238	1.494E-06	14010.377
2.250	1.623E-08	69220.000	1.193	1.731E-04	1884.000	2.204	1.262E-06	11829.548
2.749	9.299E-09	39660.000	1.554	1.211E-04	1318.000	1.377	1.016E-06	9524.956
2.750	9.297E-09	39650.000	1.765	1.174E-04	1277.000	1.729	7.700E-07	7218.959
1.057	1.806E-09	7704.000	1.434	1.116E-04	1214.000	1.509	5.537E-07	5190.956
1.000	1.554E-09	6626.000	1.875	1.058E-04	1151.000	1.847	5.364E-07	5029.035
1.001	1.552E-09	6620.000	1.868	1.019E-04	1109.000	1.155	4.271E-07	4003.970
1.005	7.229E-10	3083.000	1.394	7.500E-05	816.100	1.738	4.005E-07	3755.040
1.014	5.740E-10	2448.000	1.911	7.119E-05	774.600	2.447	3.924E-07	3679.002
1.009	5.620E-10	2397.000	1.237	6.925E-05	753.500	1.401	3.502E-07	3282.964
1.041	5.573E-10	2377.000	1.593	6.696E-05	728.600	1.831	3.159E-07	2962.028
1.085	2.191E-10	934.300	1.125	6.330E-05	688.800	1.407	3.130E-07	2935.025
1.738	7.690E-12	32.800	1.353	4.674E-05	508.600	1.408	3.128E-07	2932.963
1.831	6.066E-12	25.870	1.937	4.165E-05	453.200	2.118	3.055E-07	2863.956
1.510	4.928E-12	21.020	1.694	3.616E-05	393.500	1.661	2.905E-07	2723.974
1.193	4.877E-12	20.800	1.759	3.077E-05	334.800	1.510	2.566E-07	2406.038

TABLE 2 - Top 20 Gamma Lines > 1 MeV intrinsic to each material (8 kg WGPu aged 22.5 yrs., 1.7 kg NatU aged 50 yrs., 25 kg HEU aged 50 yrs.)

For comparison, gamma ray yields for the 25 kg HEU solid and shell core gamma intrinsic source spheres, canned with 1 cm aluminum, and aged for 50 years were computed.

5 The spectrum from HEU is described below and shown herein as optimized for computation by analysis of a 3000 (1 keV) source bin structure, later reduced for computational efficiency to approximately 1100 bins. The results were rendered by a high fidelity MCNP5 Monte Carlo (continuous energy cross sections) model. Presented here is the energy dependent leakage due to intrinsic gamma radiation leaking out from just one side panel (+x) of the “source box” in Fig 1
 10 with the panel center at a radius of 25cm from the origin of the centrally placed source. In this case, each side panel of the square source box has overall dimensions 50 cm x 50 cm; this was later increased to 60 cm x 60 cm to accommodate additional direct source shielding and packaging scenarios. For the calculations, the following data applies:

- Solid core: While average statistical convergence for the solid core was 3.64% relative
 15 error considering all energies, most of the predominant gamma lines were converged to

<1% relative error using the MCNP5 Monte Carlo code with continuous energy cross sections; to achieve these reasonably converged statistics throughout all energies, the solid pack HEU source was executed on HSWT's Viper cluster using 23.4 billion histories.

- 5 - Shell Core: While average statistical convergence for the solid core was 2.45% relative error considering all energies, most of the predominant gamma lines were converged to <1% relative error using the MCNP5 Monte Carlo code with continuous energy cross sections; to achieve these reasonably converged statistics throughout all energies, the shell HEU source ($r_i=12.458$ cm, $r_o=13.087$ cm) was executed on HSWT's Viper
10 cluster using 26.3 billion histories.

For intrinsic gammas 1 MeV or greater, the relative ratio of shell/solid gamma rays leaking at the source box averaged 3.19.

The comparison of high energy gamma ray leakage from one single panel of a source box from an HEU solid core sphere (25 kg) versus an HEU shell configuration (25 kg) is presented in
15 Table 3. Yields for the 25 kg HEU solid core gamma intrinsic source spheres, canned with 1 cm aluminum, and aged for 1 year since separation and 50 years since separation are compared below following computational optimization starting with a 3000 (1 keV) source bin structure, later reduced for computational efficiency to approximately 1100 bins; the results were rendered by a high fidelity MCNP5 Monte Carlo (continuous energy cross sections) model. Note from
20 this data there is a large difference between one year and fifty year aged HEU materials, and relative ratios of high energy gammas may be used to define the material. Source localization in a container for such sources would be determined by relative detector response based on placement on the container.

The energy dependent leakage due to intrinsic gamma radiation leaking out from just
25 one side panel (+x) of a "source box" with the panel center at a radius of 25cm from the origin of the centrally placed source is given in Figs. 3 and 4. Each side panel of the square source box has overall dimensions 50 cm x 50 cm.

[A]	[B]	[C]%	[D]	[E]	[F]	[G]	[H]%	[I]	[J]	[K]	[L]%
1.000	763.1	0.19	Pa-234m	3.45	1.000	2629.5	0.09	1.00	1.000	763.4	0.15
1.001	763.9	0.19	Pa-234m	3.44	1.001	2626.5	0.09	1.00	1.001	762.4	0.15
1.120	409.5	0.17	Pa-234m, Pb-211, Bi-214, Ac-228	3.35	1.120	1373.0	0.09	0.02	1.120	6.5	0.17
1.155	46.7	0.18	Pa-234	3.34	1.155	156.3	0.09	0.01	1.155	0.3	1.02
1.193	49.8	0.21	Pa-234m, Pb-211	3.00	1.193	149.6	0.11	0.65	1.193	32.4	0.13
1.238	171.1	0.17	Pa-234m, Pb-211, Bi-214	3.32	1.238	567.7	0.09	-	1.238	0.3	0.89
1.377	143.6	0.15	Bi-214	3.16	1.377	453.2	0.08	0.03	1.377	4.0	0.29
1.385	30.9	0.21	Bi-214	3.10	1.385	95.6	0.11	0.05	1.385	1.5	0.47
1.401	45.1	0.16	Bi-214	3.23	1.401	145.5	0.08	-	1.401	0.2	1.19
1.407	43.8	0.18	Bi-214	3.18	1.407	139.1	0.09	0.02	1.407	1.1	0.57
1.408	40.5	0.16	Bi-214, Pa-234m	3.23	1.408	130.8	0.09	0.01	1.408	0.2	1.20
1.509	78.7	0.16	Bi-214, Pa-234m	3.16	1.509	248.8	0.08	0.02	1.509	1.3	0.54
1.510	34.9	0.16	Bi-214, Pa-234m	3.19	1.510	111.4	0.08	0.99	1.510	34.4	0.13
1.661	42.8	0.16	Bi-214, Pa-234	3.14	1.661	134.5	0.09	0.01	1.661	0.4	1.01
1.729	115.3	0.15	Bi-214, Pa-234m	3.12	1.729	359.9	0.08	0.01	1.729	0.9	0.66
1.738	58.4	0.15	Pa-234, Pa-234m	3.15	1.738	183.9	0.08	0.99	1.738	58.0	0.12
1.764	587.3	0.15	Bi-214, Pa-234m	3.14	1.764	1845.0	0.08	-	1.764	0.5	0.58
1.831	47.2	0.15	Pa-234	3.12	1.831	147.4	0.08	1.00	1.831	47.1	0.12
1.847	81.0	0.15	Pa-234	3.12	1.847	252.7	0.08	-	1.847	0.3	0.78
2.118	48.9	0.15	Bi-214	3.08	2.118	150.5	0.08	-	2.118	0.0	0.16
2.204	201.2	0.14	Bi-214	3.09	2.204	620.9	0.08	-	2.204	0.1	0.12
2.447	64.7	0.14	Bi-214	3.06	2.447	198.1	0.08	-	2.447	0.0	0.38
[A] - Gamma MeV						[G] - 50 yr. Shell Core J+ gam/s, Box Surface					
[B] - 50 yr. Solid Core J+ gam/s, Box Surface						[H] - 50 yr. Shell relative MC error					
[C] - 50 yr. Solid relative MC error						[I] - 1 yr. Solid/50 yr. Solid Ratio					
[D] - Attributed Nuclide(s) in HEU Decay Chain						[J] - Gamma MeV					
[E] - Shell/Solid Ratio						[K] - 1 yr. Solid Core J+ gam/s, Box Surface					
[F] - Gamma MeV						[L] - 1 yr. Solid relative MC error					

TABLE 3 - Source box (+x) planar leakage current values and attributed isotopes rendered using MC transport for 25 kg HEU (90%) masses canned in 1 cm thick Al

The total leakage over all energies streaming out of the Al spherical case on one planar surface set across a 50 cm x 50 cm surface is similar for the two aged masses, dominated by the

5 lower energies.

The following important trends for aged HEU have been found. First, protactinium gammas in the decay series for uranium (Pa-234/234m) reach decay series equilibrium quickly, with emissions becoming fairly constant between one year and fifty years. Further, bismuth gamma (Bi-214) emission rates are extremely sensitive to material age, ramping up with aged material. Finally, relative to the fifty year decay emissions, bismuth (Bi-214) requires nearly
5 twenty years to reach just under 20% of the fifty year emission level, then subsequently ramps almost linearly relative to the fifty year level.

Taking, for example, the 2.204 MeV gamma, which is attributed to Bi-214 in-growth, Fig. 5 shows the fundamental decay gamma source yields for this line in the source material, demonstrating the behavior as a function of age determined for 1, 10, 22.5, and 50 years since
10 separation of the 25 kg HEU mass.

The absolute value of the difference between the two materials (one year and fifty years) is shown graphically in Fig. 6.

It was further determined that, for HEU sources of the same age since separation, shell
15 sources provide more than three times (3x) the gamma strength compared to solid sources for gamma energies above 1 MeV. Further, exploitable gamma signatures for uranium improve with age; much of the improvement is driven by Bi-214 related daughter in-growth. Aged uranium does not achieve a significant advantage over uranium separated within 1 year until the age of the uranium exceeds at least twenty years. There are also at least seven (7) other gamma lines
20 that should be considered for 1 year HEU that may be used with the present invention, even with heavy shielding from a localized source. Such energies are 0.742, 0.766, 1.0005, 1.193, 1.510, 1.738, and 1.831 MeV gammas. It should be noted that for all plots herein, since gamma sources were broken down to 1 KeV bin resolution, the 1.0005 MeV gamma line counts are split between the 1.000 and 1.001 bins.

Fig. 7 shows a 25 kg HEU shell source (13.0866 cm outer radius) shielded with 1 cm of
25 Al, with a 30 cm radius Source Box as modeled using MCNP5. The bottom surfaces represent the wood floor and steel shell (homogenized with air over 1 cm) of the shipping container. Fig. 8 shows the gamma radiation leakage for 1 year aged 25 kg HEU shell source shielded with 1 cm of Al, in the 30 cm radius Source Box. The inset data shows the count rate and ratio to 1 MeV at

the source box. Fig. 9 shows gamma radiation leakage for 22.5 year aged WGPu at a 60 cm by 60 cm source plane centered 30 cm away from an 8 kg shell source canned in 1 cm thick aluminum.

In one embodiment, the above-described method may be implemented using a system such as that described by U.S. Provisional Patent Application No. 60/388,512 and U.S. Patent No. 6,891,470, the entire contents of each of which are incorporated by reference herein. For example, Fig. 10 shows a schematic representation of a container storage facility or transport 10, which in this particular example may store a plurality of box-like containers or other objects to be tested 12. For example, the containers 12 may be preloaded with goods to be shipped from one location to another. Typically, the containers 12 preloaded with the goods to be shipped are sealed before being placed in a transport, such as a ship or truck. Shipping containers 12 of this type are typically made of steel or some other rigid, high strength material in order to provide adequate support and to adequately protect the goods being shipped within each container 12 from damage which may occur during shipment and the loading/unloading of the containers 12.

Fig. 11 is a functional schematic block diagram of a radioactive material detection apparatus 20 in accordance with a preferred embodiment of the present invention. The radioactive material detection apparatus 20 is contained within a housing 22 which is preferably sealed and is made of a generally rigid high strength material such as a polymeric material. Preferably, the sensor housing 22 is tamper resistant and includes a mechanism for identifying by a quick, visual or other inspection whether the housing 22 has been opened or otherwise tampered with and or an internal electronic circuit to detect tampering. The housing 22 is adapted to be secured to the inside or outside of a container 12 at a predetermined location. Various techniques and methods well known to those of ordinary skill in the art may be employed for securing the housing 22 to the container 12 including the use of one or more mechanical fasteners such as screws, bolts, clamps, or the like, the use of an adhesive or epoxy adhesive, suction cups, a magnetic attachment device or any other suitable attachment device or technique. Preferably, the housing 22 is adapted to be temporarily secured to an interior or exterior surface of the container 12. Thus, the radioactive material detection apparatus 20 may be a portable unit. However, it is within the scope and spirit of the present invention that the housing 22 be permanently secured to a container 12. Preferably, the location on the container

12 where the housing 22 is secured will be such that the housing 22 will not affect the loading or unloading of the container 12 or the stacking of the containers 12. Preferably, the housing 22 is relatively small as compared to the container 12 or other object to be tested.

Referring again to Fig. 11, the housing 22 contains the components necessary for passive
5 detection of the presence of radioactive material over an extended time period. For example, the containers 12 may be tested during the time period in which the container transport 10 moves from one destination to another. In the present embodiment, the housing 22 includes a gamma radiation detection sensing component or sensor 24, a transmitter 26, an identification component or ID tagger 28, a controller 30, a location component or tagger 32 and a power
10 source 34 for providing operating power to the other components as needed. Preferably, the gamma radiation sensor component 24 is a self-contained passive device capable of sensing the presence of gamma radiation emitted from radioactive material which may be present within or near the container 12 to which the radioactive material detection apparatus 20 is attached. The gamma radiation sensing component 24 is preferably of a type which is generally well known to
15 those of ordinary skill in the art and is available from several sources. The gamma radiation sensing component 24 provides an electrical output signal which is proportional to the sensed gamma radiation. The output from the gamma radiation sensing component 24 may be supplied as an input to the controller 30, which may be configured to perform the ratio calculations of the detected gamma photon ranges, as well as determined whether a threshold ratio has been
20 exceeded. Alternatively, the output of the gamma radiation sensing component 24 may be supplied as an input to the transmitter 26. The transmitter 26 communicates with an external controller 40, which receives the data signal representing the gamma photon counts for use in determining the ratio and preferably the determination of the radioactive anomaly. The external controller 40 may be housed in an external computing device 42, such as a base station
25 computer, portable device, or the like. The output of the radiation sensor 24 may be output to the transmitter 26 once following the entire testing period, or may be accumulated over multiple intervals of time and sent in portions to the transmitter 26. Suitable signal conditioning components (not shown) may be interposed between the gamma radiation sensing component 24 and the transmitter 26.

Optionally, one of the controllers 30, 40 may be coupled to an indicator 50, such as a visual or audible alarm, which alerts operators that a threshold value of the gamma ratio has been exceeded, or other conditions.

Fig. 12 is a flow chart for one embodiment of a method utilizing the above-described ratios for detection of a radioactive anomaly. At step 1202, one or more radioactive material detection apparatuses 20 detect gamma photons having energies within at least two ranges of energy values. At step 1204, the data is fed to a controller 30 or 40 for analysis and computation a ratio of the number of detected gamma photons in a first range and the number of detected gamma photons in a second range. In this particular embodiment, at step 1206, the calculated ratio is compared to a threshold value, such as the ratio for NORM. If the threshold is exceeded, at step 1208 the presence of a radioactive anomaly is indicated.

It is conceivable that with knowledge of the first and second ranges, nefarious individuals may attempt to dope the material to be tested with particular isotopes in an effort to have the ratio appear to be similar to NORM. The testing for additional ratios at step 1210 can compensate for this effect. For example, embodiments of the present invention allow for the determination of additional ranges, which may overlap with one or more of the first and second ranges, from which additional ratios may be calculated for the detection of a radioactive anomaly. As one example, if the first ratio compares 830-1060 keV gamma counts with 1060-3000 keV gamma counts, a secondary check ratio may compare 1000-2000 keV gamma counts with 2000-2500 keV gamma counts. As another example, the secondary check ratio may compare 830-1060 keV gamma counts with gamma counts in the 2500-3000 keV range. By performing multiple ratio calculations with varying ranges, it becomes even more difficult to hide weapons grade materials.

In another preferred embodiment, gamma energy spectrum ratios may be used for materials verification. For example, the technique may be used to verify the counts of nuclear warheads in storage. In this instance, an expected ratio for the warhead within container 12 can be determined based on the age of the warhead. Fig. 13 is a flow chart representing this method embodiment. At step 1302, one or more radioactive material detection apparatuses 20 detect gamma photons having energies within at least two ranges of energy values. At step 1304, the

data is fed to a controller 30 or 40 for analysis and computation a ratio of the number of detected gamma photons in a first range and the number of detected gamma photons in a second range. In this particular embodiment, at step 1306, the calculated ratio is compared to the expected value for the warhead. If the calculated ratio and expected ratio do not match, there is reason to
5 suspect that the warhead had been replaced by “dummy” material.

The above provides only examples for using gamma energy spectrum ratios for detecting the presence or absence of radioactive materials in storage or shipping, and is not meant to be limiting. It will be appreciated that the invention is not limited to homeland security or discrimination during shipping or storage, and can be used for a variety of different purposes
10 requiring discrimination of HEU or other materials of interest from naturally occurring radioactive materials.

From the foregoing, it can be seen that embodiments of the present invention comprise a method of discriminating a radioactive anomaly, particularly HEU from naturally occurring radioactive materials. It will be appreciated by those skilled in the art that changes could be
15 made to the embodiments described above without departing from the broad inventive concept thereof. It is understood, therefore, that this invention is not limited to the particular embodiments disclosed, but it is intended to cover modifications within the spirit and scope of the present invention as defined by the appended claims.

CLAIMS

We claim:

1. A method for discriminating a radioactive anomaly from naturally occurring
5 radioactive materials, the method comprising:
 - detecting a first number of gamma photons having energies in a first range of energy values within a predetermined period of time;
 - detecting a second number of gamma photons having energies in a second range
of energy values within the predetermined period of time;
 - 10 determining, in a controller, a ratio of the first number of gamma photons having energies in the first range and the second number of gamma photons having energies in the second range; and
 - determining that a radioactive anomaly is present when the ratio exceeds a
threshold value.
- 15 2. The method of claim 1, wherein the radioactive anomaly is highly enriched uranium (HEU).
3. The method of claim 2, wherein the first range of energy values is between about
20 830 keV and about 1060 keV.
4. The method of claim 3, wherein the second range of energy values is between about 1060 keV and about 3000 keV.
- 25 5. The method of claim 4, wherein the threshold value represents naturally occurring radioactive material (NORM) and is about 0.43.
6. The method of claim 1, further comprising:
 - detecting a third number of gamma photons having energies in a third range of
30 energy values within the predetermined period of time;

detecting a fourth number of gamma photons having energies in a fourth range of energy values within the predetermined period of time; and

determining, in the controller, a ratio of the third number of gamma photons having energies in the third range and the fourth number of gamma photons having energies in the fourth range.

5

7. The method of claim 6, wherein at least one of the third and fourth ranges is different from the first and second ranges.

10

8. The method of claim 7, wherein at least one of the third and fourth ranges overlaps with at least one of the first and second ranges.

15

9. The method of claim 1, further comprising:

placing one or more radioactive material detection apparatuses onto an object to be tested, the one or more radioactive material detection apparatuses being configured to detect the first and second numbers of gamma photons.

20

10. The method of claim 9, wherein at least one of the one or more radioactive material detection apparatuses includes the controller for determining the ratio of the first and second numbers of gamma photons.

25

11. The method of claim 9, wherein the controller for determining the ratio of the first and second numbers of gamma photons is located remotely from the one or more radioactive material detection apparatuses, the method further comprising:

transmitting, from the one or more radioactive material detection apparatuses, data representative of the detected first and second numbers of gamma photons to the controller.

30

12. The method of claim 1, wherein the controller determines that the threshold value is exceeded by the ratio of the first and second numbers of gamma photons.

13. The method of claim 12, wherein the controller provides a warning indication when the threshold value is exceeded.

14. The method of claim 1, wherein the radioactive anomaly is plutonium.

5

15. A method for determining the presence or absence of an expected radiation source, the method comprising:

placing at least one radioactive material detection apparatus on an object containing the expected radiation source;

10

detecting, with the at least one radioactive material detection apparatus, a first number of gamma photons emitted by the expected radiation source having energies in a first range of energy values within a predetermined period of time;

15

detecting, with the at least one radioactive material detection apparatus, a second number of gamma photons emitted by the expected radiation source having energies in a second range of energy values within the predetermined period of time;

determining, in a controller, a ratio of the first number of gamma photons having energies in the first range and the second number of gamma photons having energies in the second range; and

20

comparing the determined ratio of the first and second numbers of gamma photons with an expected ratio of the first and second numbers of gamma photons for the expected radiation source.

16. A system for discriminating a radioactive anomaly from naturally occurring radioactive materials, the system comprising:

25

at least one radioactive material detection apparatus configured to detect a first number of gamma photons having energies in a first range of energy values within a predetermined period of time and a second number of gamma photons having energies in a second range of energy values within the predetermined period of time; and

a controller configured to:

- (i) determine a ratio of the first number of gamma photons having energies in the first range and the second number of gamma photons having energies in the second range, and
- (ii) compare the determined ratio with a threshold value.

5

17. The system of claim 16, wherein the controller is remotely located from and in communication with the at least one radioactive material detection apparatus.

18. The system of claim 17, wherein the at least one radioactive material detection apparatus is configured to communicate wirelessly with the controller.

10

19. The system of claim 18, wherein the controller is housed by the at least one radioactive material detection apparatus.

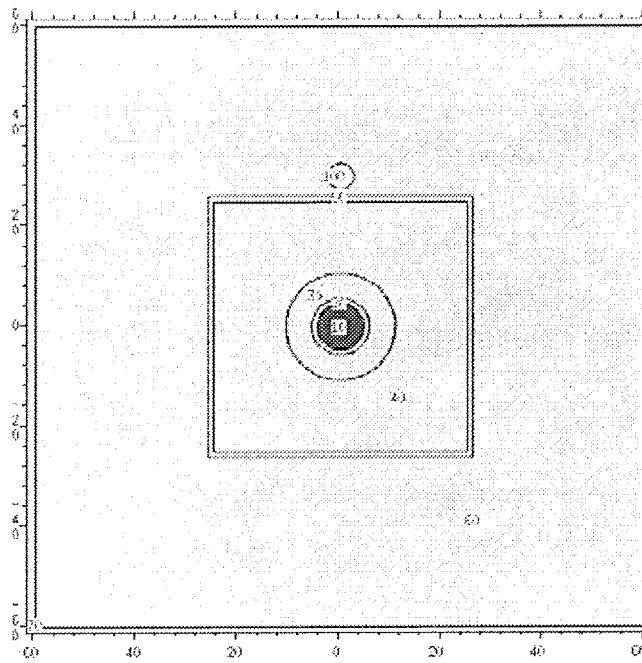

FIG. 1

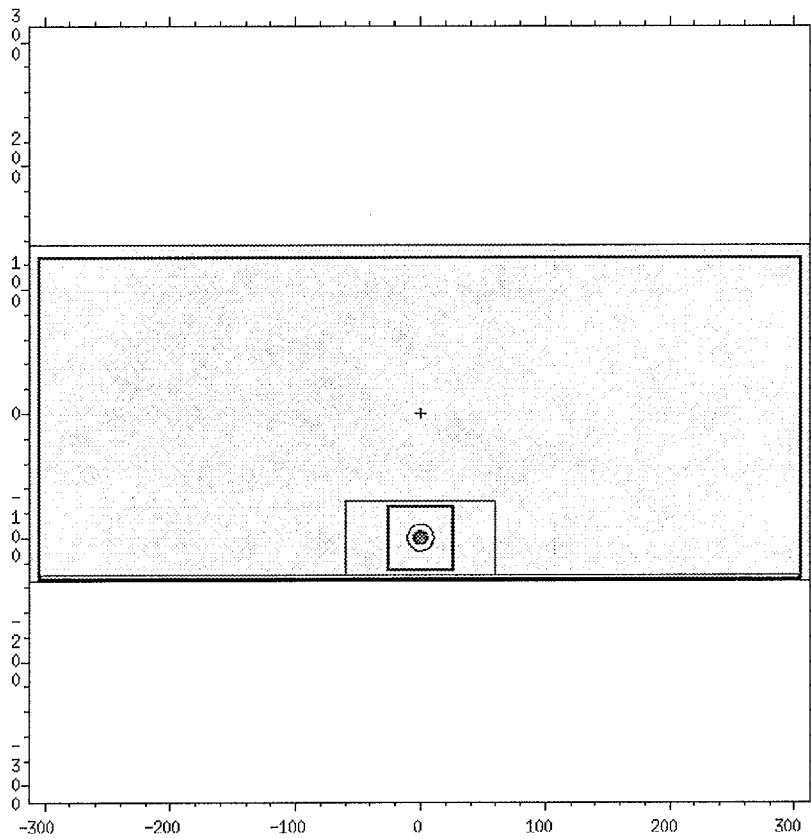

FIG. 2

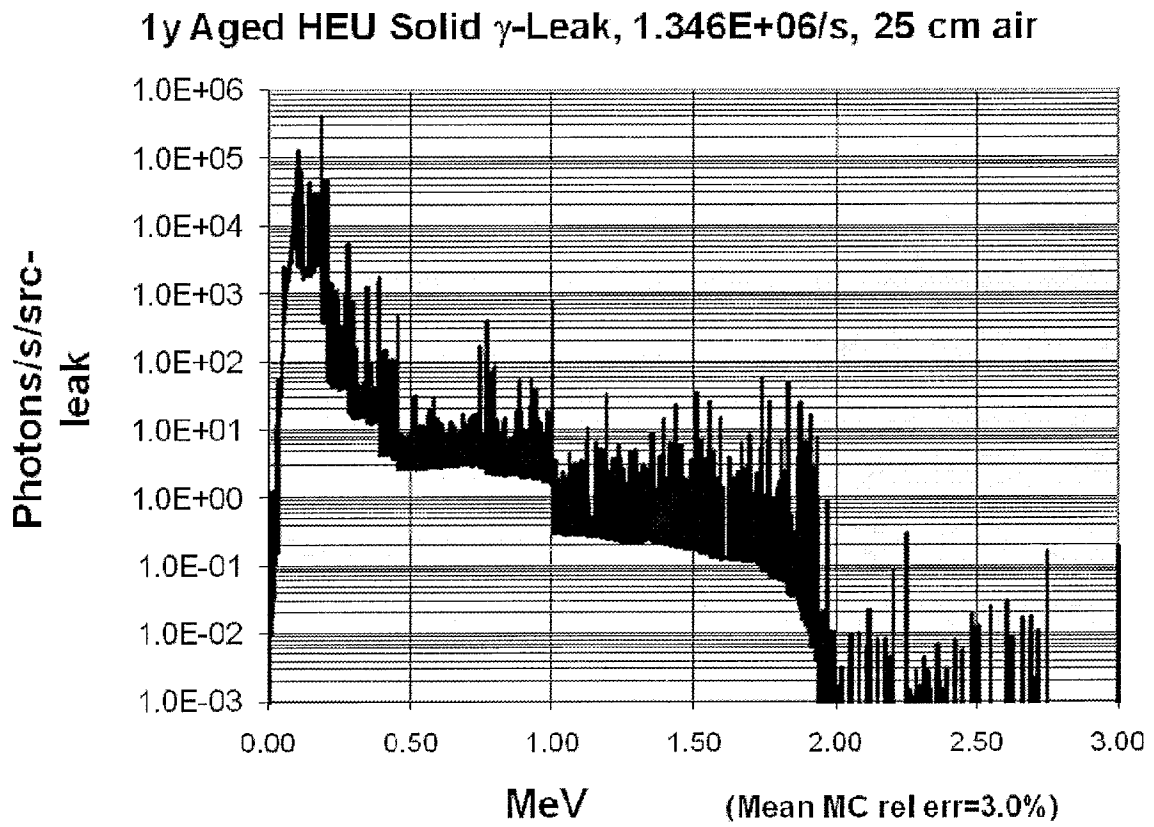

FIG. 3

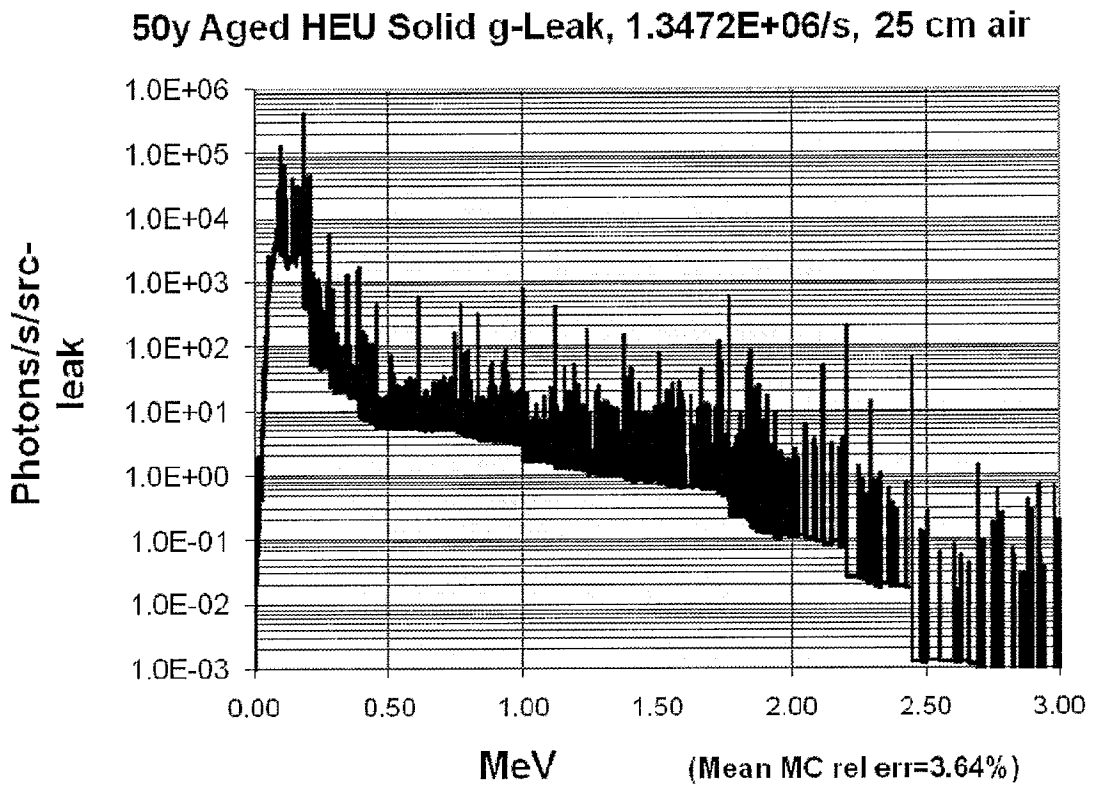

FIG. 4

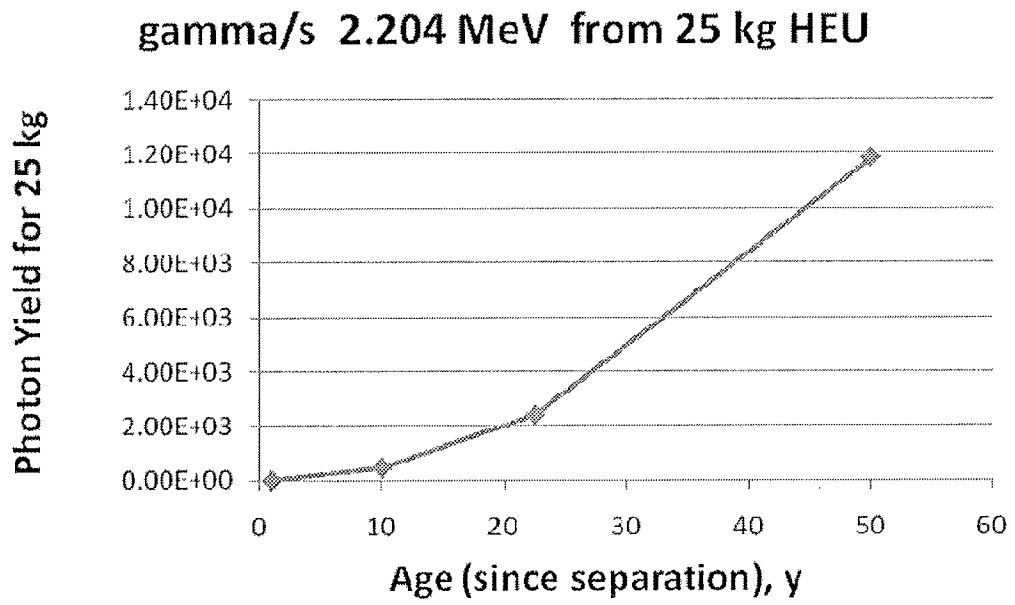

FIG. 5

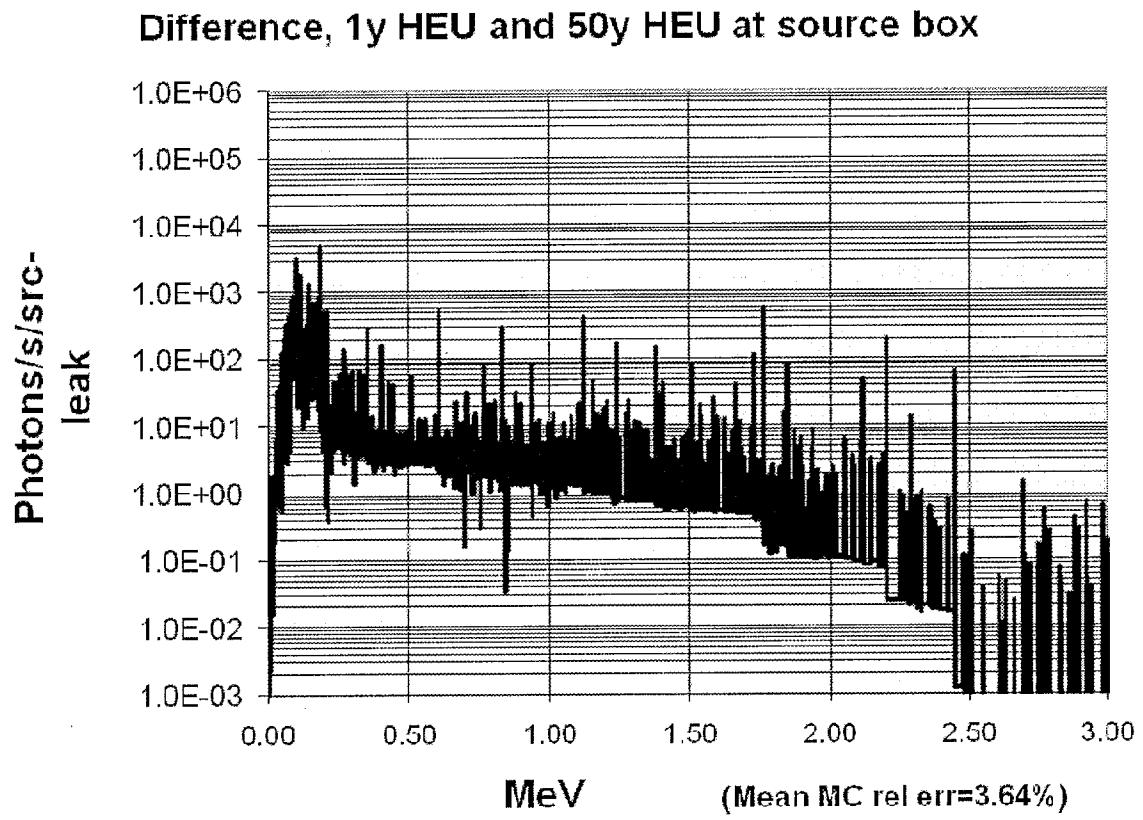

FIG. 6

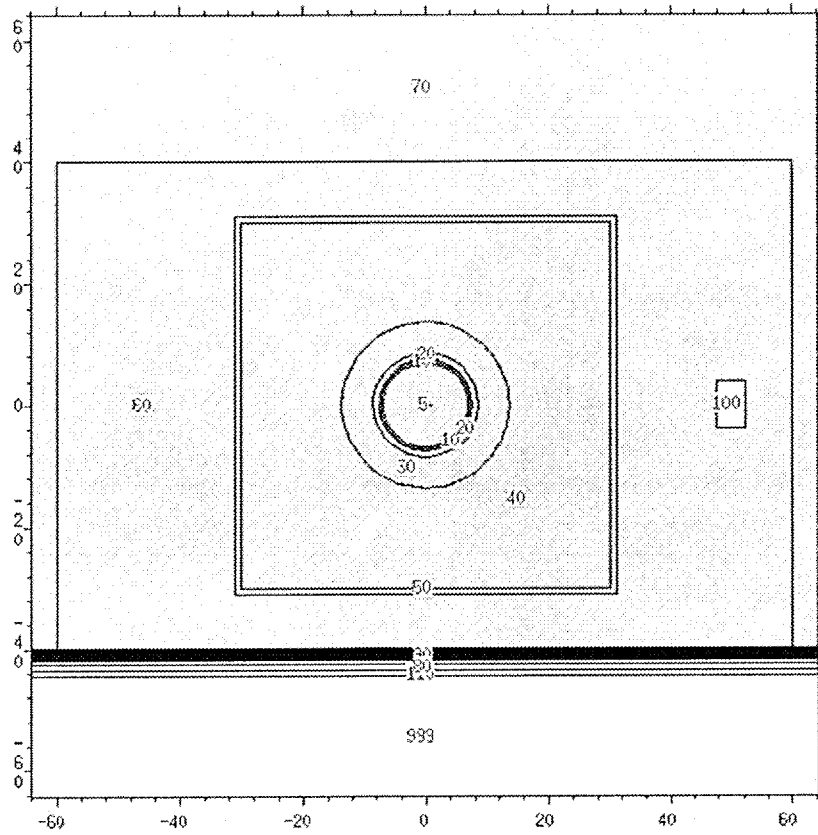

FIG. 7

1y Aged HEU Shell γ -Leak, 4.8395E+06/s, 30 cm air

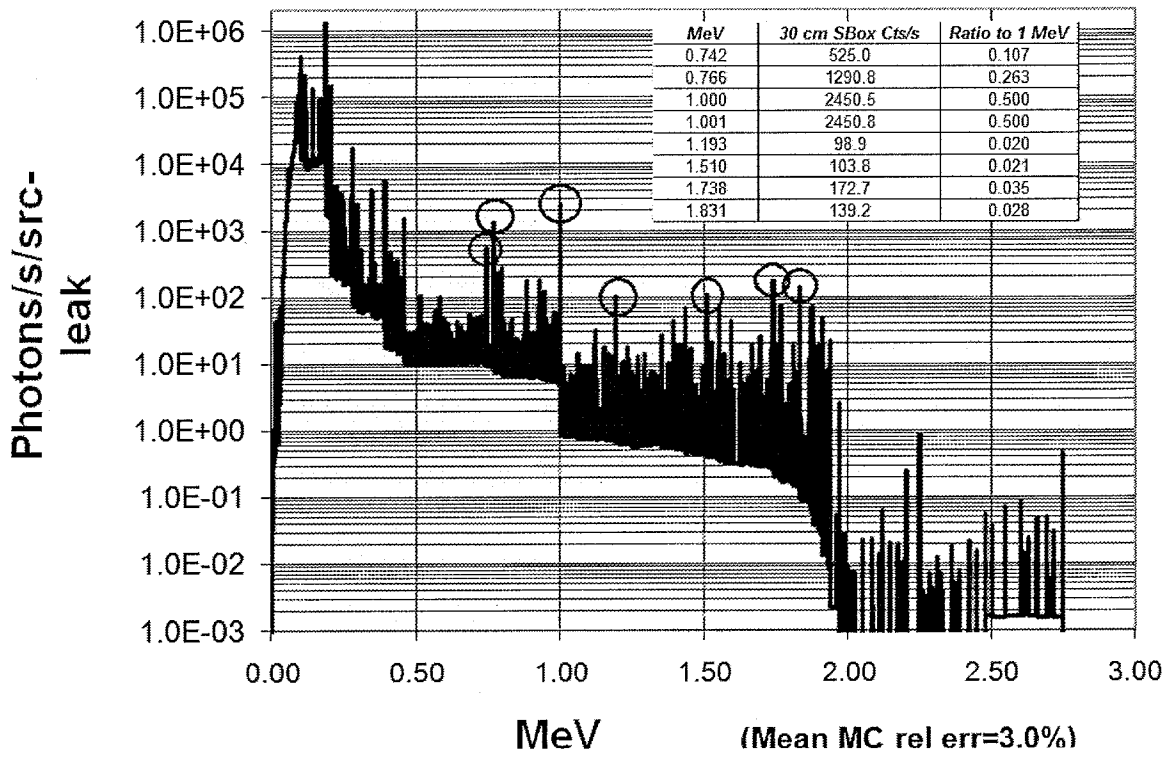

FIG. 8

22.5 y Aged Pu Shell γ -Leak, 3.5323E08/s, 30 cm air

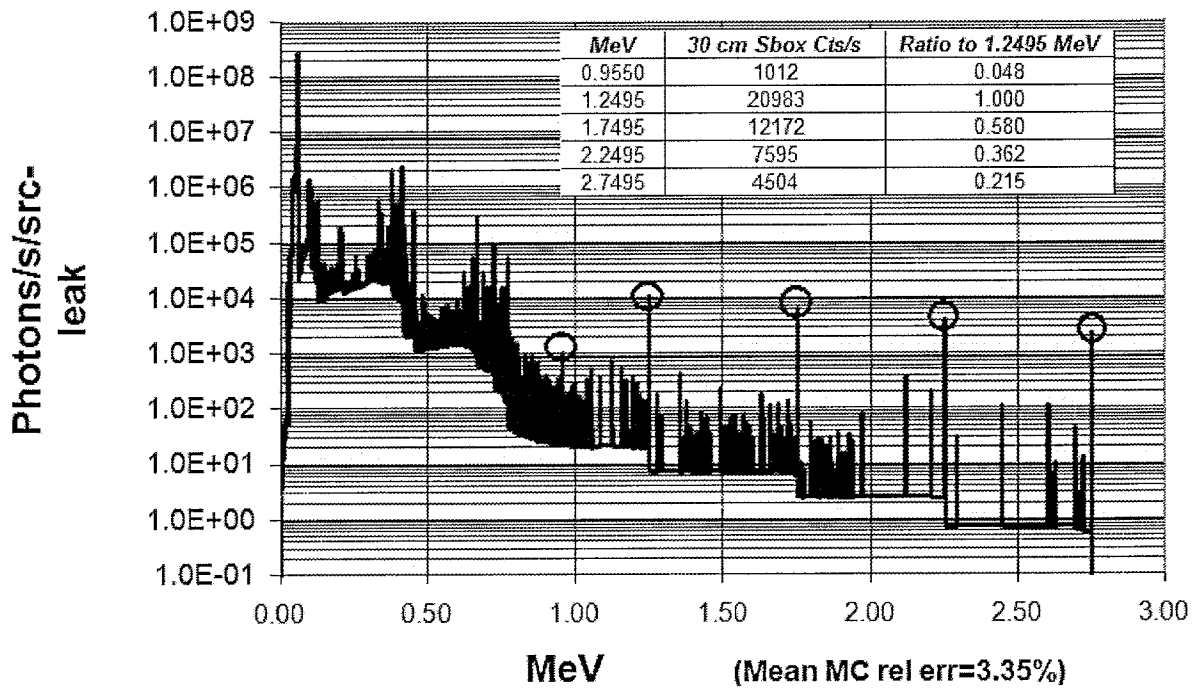

FIG. 9

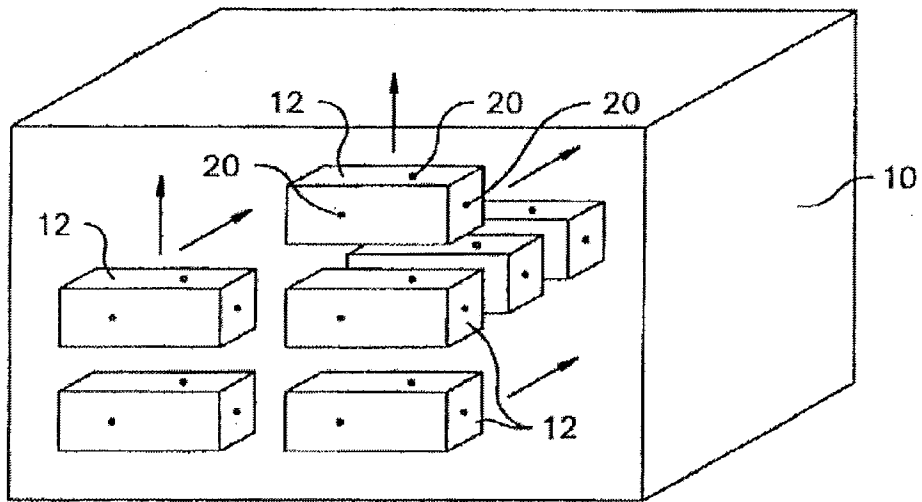

FIG. 10

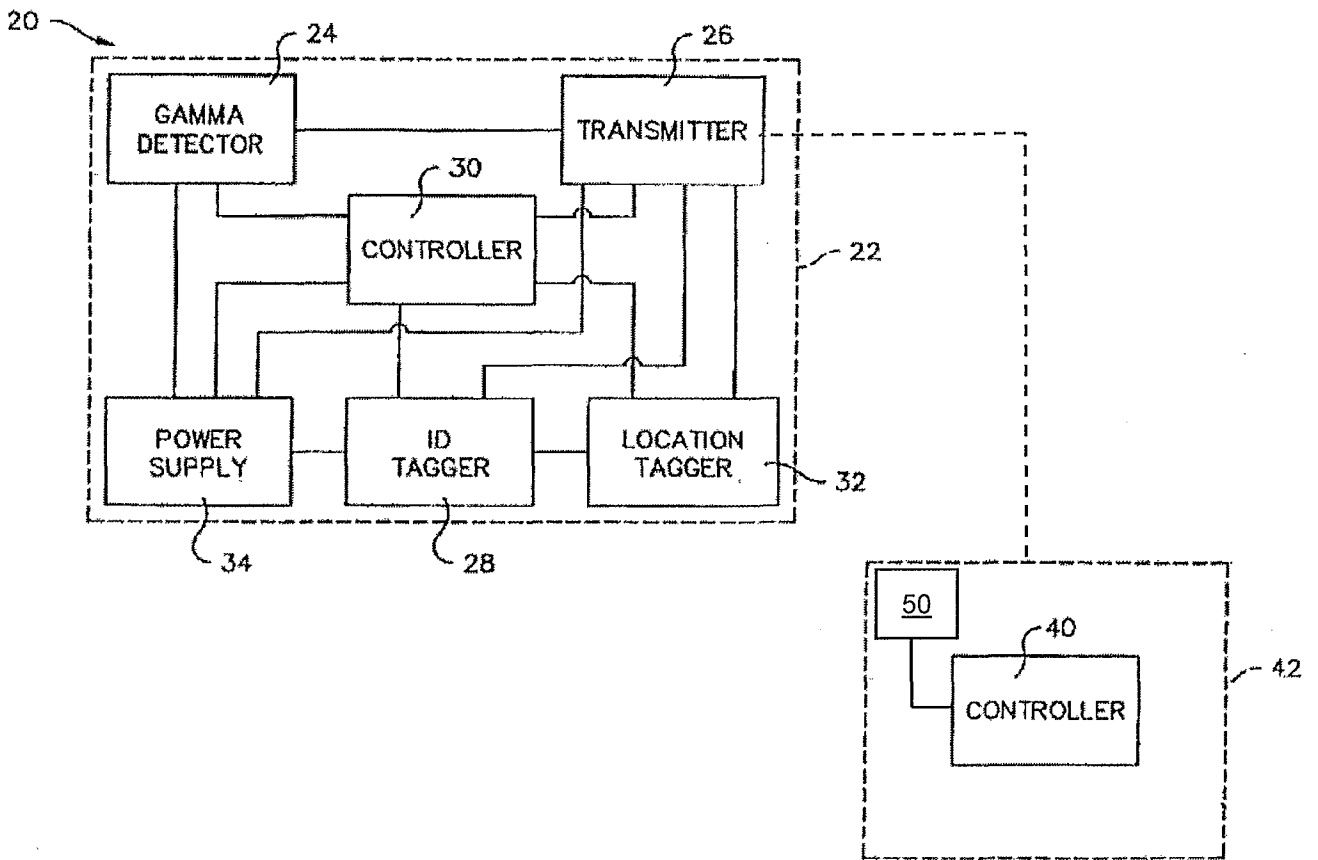

FIG. 11

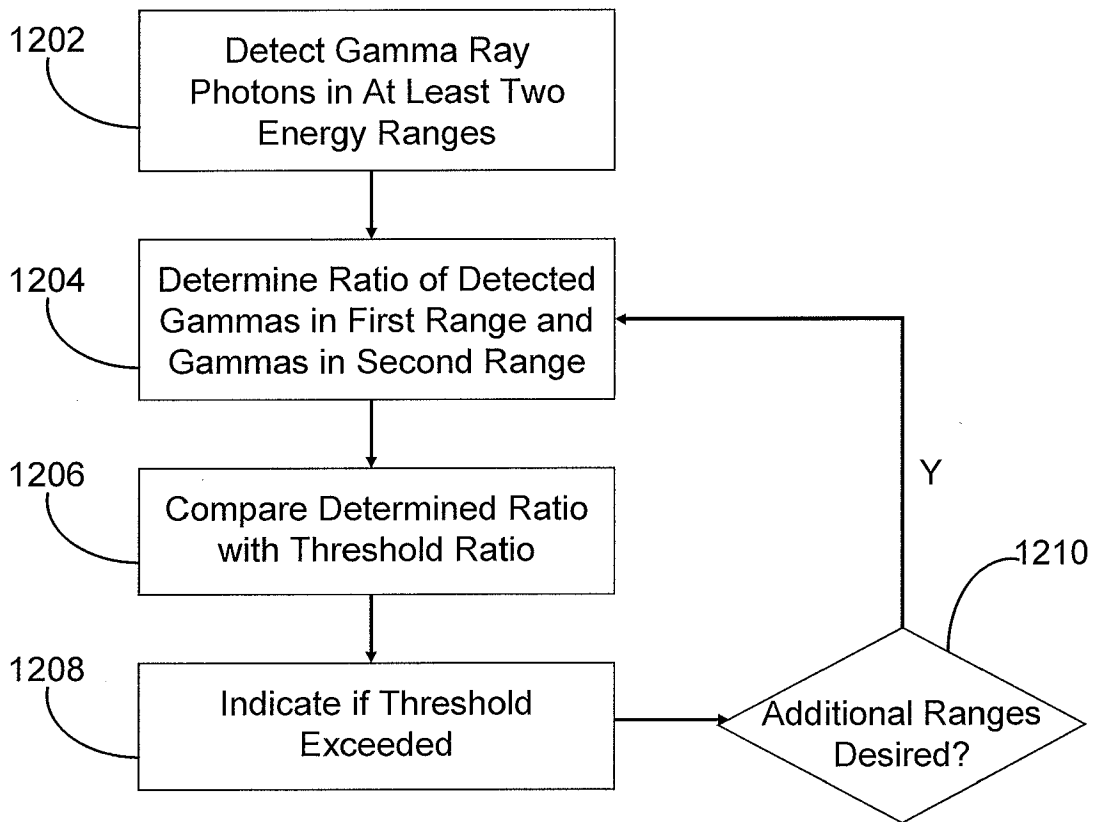

FIG. 12

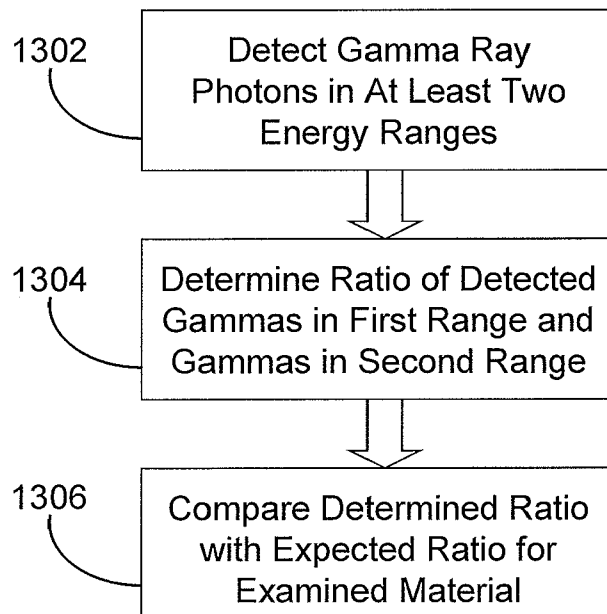

FIG. 13

INTERNATIONAL SEARCH REPORT

International application No.

PCT/US2011/067557

A. CLASSIFICATION OF SUBJECT MATTER

IPC(8) - G01T 1/36 (2012.01)

USPC - 250/370.06

According to International Patent Classification (IPC) or to both national classification and IPC

B. FIELDS SEARCHED

Minimum documentation searched (classification system followed by classification symbols)

IPC(8) - G01T 1/00, 36, 38; G01N 23/00 (2012.01)

USPC - 250/370.03, 370.06, 370.11, 371

Documentation searched other than minimum documentation to the extent that such documents are included in the fields searched

Electronic data base consulted during the international search (name of data base and, where practicable, search terms used)

PatBase, Google Patents, Google Scholar

C. DOCUMENTS CONSIDERED TO BE RELEVANT

Category*	Citation of document, with indication, where appropriate, of the relevant passages	Relevant to claim No.
X		1, 2, 6-19
---	US 2005/0275545 A1 (ALIOTO et al) 15 December 2005 (15.12.2005) entire document	-----
Y		3-5
Y	US 2010/0168947 A1 (WINSO et al) 01 July 2010 (01.07.2010) entire document	3-5
A	US 4,629,600 A (ISHIGURO et al) 16 December 1986 (16.12.1986) entire document	1-19
A	US 2004/0195517 A1 (ROWLAND et al) 07 October 2004 (07.10.2004) entire document	1-19
A	US 2010/0226580 A1 (FRANK) 09 September 2010 (09.09.2010) entire document	1-19

 Further documents are listed in the continuation of Box C.

* Special categories of cited documents:

"A" document defining the general state of the art which is not considered to be of particular relevance

"E" earlier application or patent but published on or after the international filing date

"L" document which may throw doubts on priority claim(s) or which is cited to establish the publication date of another citation or other special reason (as specified)

"O" document referring to an oral disclosure, use, exhibition or other means

"P" document published prior to the international filing date but later than the priority date claimed

"T" later document published after the international filing date or priority date and not in conflict with the application but cited to understand the principle or theory underlying the invention

"X" document of particular relevance; the claimed invention cannot be considered novel or cannot be considered to involve an inventive step when the document is taken alone

"Y" document of particular relevance; the claimed invention cannot be considered to involve an inventive step when the document is combined with one or more other such documents, such combination being obvious to a person skilled in the art

"&" document member of the same patent family

Date of the actual completion of the international search

30 April 2012

Date of mailing of the international search report

08 MAY 2012

Name and mailing address of the ISA/US

Mail Stop PCT, Attn: ISA/US, Commissioner for Patents
P.O. Box 1450, Alexandria, Virginia 22313-1450

Facsimile No. 571-273-3201

Authorized officer:

Blaine R. Copenheaver

PCT Helpdesk: 571-272-4300

PCT OSP: 571-272-7774