

P. S. DEVLAN.
Car Spring.

No. 111,438.

Patented Jan. 31, 1871.

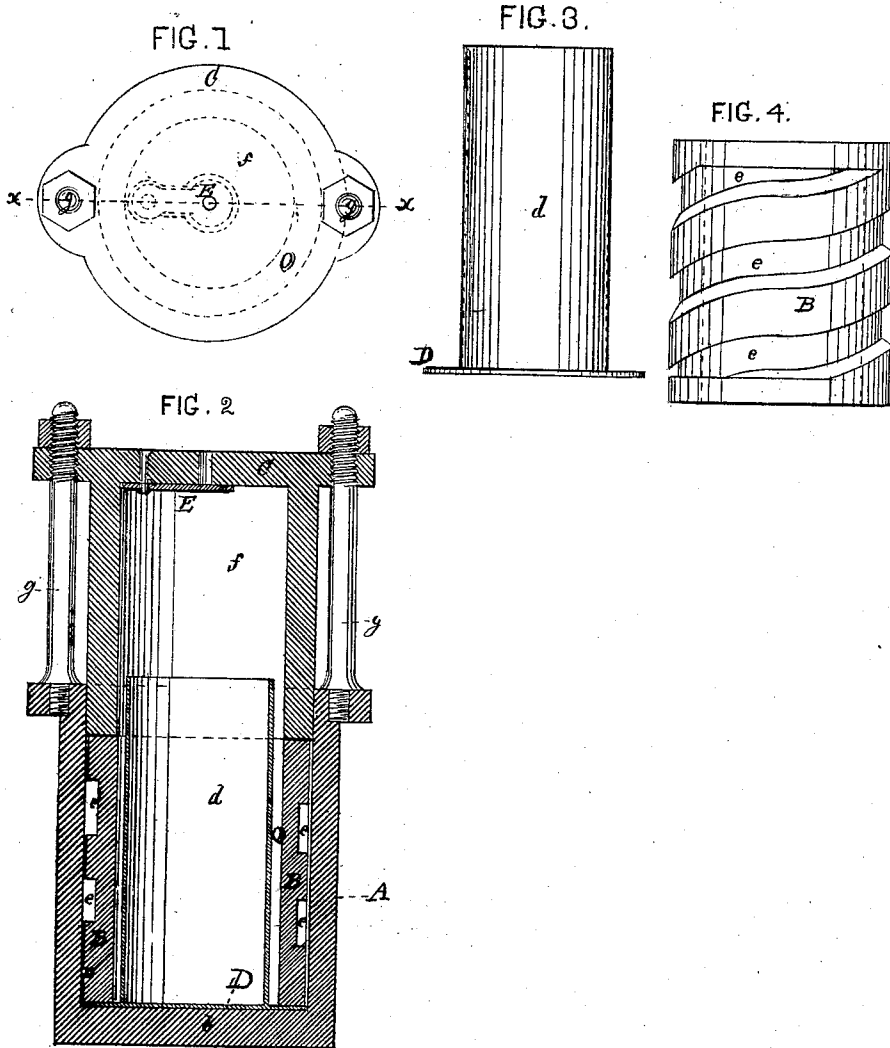

WITNESSES.

H. Ashton Henry.
Thomas J. Bayley.

INVENTOR.

Patrick S. Devlan
By his Attorney
Stephen Mottick

UNITED STATES PATENT OFFICE.

PATRICK S. DEVLAN, OF JERSEY CITY, N. J., ASSIGNOR TO HIMSELF, ISAAC P. WENDELL, AND STEPHEN P. M. TASKER, OF PHILADELPHIA, PA.

IMPROVEMENT IN COMBINED PNEUMATIC AND RUBBER SPRINGS.

Specification forming part of Letters Patent No. 111,438, dated January 31, 1871.

To all whom it may concern:

Be it known that I, PATRICK S. DEVLAN, of Jersey City, in the county of Hudson and State of New Jersey, have invented a Combined Pneumatic and Rubber Spring, of which the following is a specification.

My invention mainly consists in the combination of a hollow gum cylinder, having an air chamber or chambers in its periphery, with a metallic case and piston, in such a manner as to combine the elastic force of the air with that of the rubber, whereby a powerful spring having great sensitiveness is produced. The said chambers I usually make of spiral form, with spiral ribs between, to give a lateral and vertical stiffening to the cylinder and guide the same during its reciprocating movements.

To enable others skilled in the art to which my improvement appertains to make and use my invention, I will now give a detailed description thereof.

In the accompanying drawings, which make a part of this specification, Figure 1 is a top view of the combined spring. Fig. 2 is a vertical section at the line *x x* of Fig. 1. Fig. 3 is a side elevation of the plate D and central tube, *d*. Fig. 4 is a like view of the elastic spring B.

Like letters in all the figures indicate the same parts.

A is the cylindrical case; B, a hollow gum cylinder within the same, and C a hollow piston, whose lower edge bears upon the outer end of the spring B, as seen in Fig. 2.

In order to avoid the necessity of turning off the internal face of the bottom *b* of the case A, I place the plate D beneath the spring B. The said plate is provided with a central tube, *d*, which passes up inside the rubber cylinder B, as seen in Fig. 2. The said tube forms the interior of the annular air-chamber O, in which the gum cylinder B is placed, the inner surface of the case A forming its interior surface, the tube also serving to sustain the inner surface of the gum cylinder when the latter is subjected to great pressure, and is consequently pressed inward. The plate and its projecting tube are represented in Fig. 3.

The immense pressure of the compressed air in the interior of the gum cylinder B has the tendency of forcing the outer surface of the

cylinder hard against the interior face of the case A, and thus preventing the contraction in the length of the cylinder by the compressing-weight in such a degree as to impair its elastic force. To overcome this I recess the external surface of the cylinder, so as to form chambers *e*, when in position in the case A, as seen in Fig. 2, to contain air, which reacts against the force of the air in said cylinder, and thus prevents the jamming of the periphery of the same against the inner surface of the case A, except at its ends, so as to secure the greatest possible freedom of movement and effectiveness of the combined spring. The diameter of the upper end of the cylinder is of such size as to make an air-tight joint and yet allow the free movement of the cylinder.

The strengthening-ribs *e'*, left in recessing the cylinder, are represented in Fig. 4 as running spirally around the cylinder, forming spiral recesses *e*. This direction of the ribs is preferable, as it secures the stiffening of the cylinder both laterally and vertically. Besides, the ribs, acting as guides in the reciprocating movements of the cylinder, have less friction than horizontal ribs. Yet other forms may be given to the recesses and consequent direction to the ribs, if desired. The piston C is constructed with a chamber, *f*, to increase the extent of the central air-chamber. The said piston C is provided with an air-valve, E, to admit of a free passage of air into the chamber *f* in case of the formation of a vacuum.

The operation is as follows: The pressure of the piston C upon the outer end of the elastic cylinder B makes an air-tight joint on its end surface, and also on the peripheral surface thereof, so as to effectually prevent the escape of the air from the case A, thus utilizing the whole elastic force of the air in combination with the elastic force of the spring-cylinder, and thus obtaining a powerful spring without impairing its sensitive elasticity.

I have represented the case A and parts in connection of cylindrical form, yet it will be seen that the parts may be of any other desirable form, and that, instead of a single elastic spring, B, and corresponding piston, C, a nest or series may be contained within the case, so as to give any desirable capacity to the springs.

The case may be of circular form, as represented, or any other which may be more suitably adapted to the circumstances.

The improved spring above described is adapted to cars and all description of land-carriages which require the use of springs to give an elastic support to their bodies. It is also well adapted as a bumper for cars. It may likewise be used for various other purposes not connected with wheel-vehicles.

I am not aware that air-recesses in the peripheral surface of gum cylinders for forming air-chambers have been hitherto made. In some other pneumatic and rubber springs air-cavities have been formed by the placing of gum rings in a cylindrical case, as simply the result of bringing the rings together without intending to make such cavities, or the same materially affecting the operation of the cylinder in the manner contemplated by the use of the chambers *e*, above described.

What I claim as my invention, and desire to secure by Letters Patent, is—

1. The gum cylinder or cylinders B, having one or more recesses in their outer periphery to contain air to react against the outward pressure of the air in the interior of the cylinders, in combination with one or more pis-

tons, C, and the case A, substantially in the manner and for the purpose hereinbefore described.

2. The construction of the gum cylinder B, with spiral ribs around its periphery, forming both a horizontal and vertical stiffening of the cylinder, and suitable guides for the same in its reciprocating movements, as above set forth.

3. The combination of the plate D and tube *d*, and the combination thereof with the case A and cylinder B, as and for the purpose set forth.

4. One or more annular spaces, O, in combination with one or more gum cylinders, B, and piston or pistons C, when the said cylinders are so arranged within the chambers that there shall be air chambers or spaces around the inner and outer surfaces of the cylinders, as and for the purpose set forth.

In testimony that the above is my invention I have hereunto set my hand and affixed my seal this 1st day of October, 1870.

PATRICK S. DEVLAN. [L. S.]

Witnesses:

STEPHEN USTICK,
THOMAS J. BEWLEY.