

(12) INTERNATIONAL APPLICATION PUBLISHED UNDER THE PATENT COOPERATION TREATY (PCT)

(19) World Intellectual Property Organization
International Bureau



(43) International Publication Date
30 November 2000 (30.11.2000)

PCT

(10) International Publication Number
WO 00/71297 A1

- (51) International Patent Classification⁷: B24B 37/04, 21/04, B24D 11/04, 11/00
- (21) International Application Number: PCT/US00/13328
- (22) International Filing Date: 15 May 2000 (15.05.2000)
- (25) Filing Language: English
- (26) Publication Language: English
- (30) Priority Data: 09/316,166 21 May 1999 (21.05.1999) US
- (71) Applicant: LAM RESEARCH CORPORATION [US/US]; 4650 Cushing Parkway, Fremont, CA 94538-6470 (US).
- (72) Inventors: JENSEN, Alan, J.; 1515 South East 26th Court, Troutdale, OR 97060 (US). THORNTON, Brian, S.; 1592 Eisenhower Drive, Santa Clara, CA 95054 (US).
- (74) Agent: GENIN, Kent, E.; Brinks Hofer Gilson & Lione, P.O. Box 10087, Chicago, IL 60610 (US).
- (81) Designated States (national): IL, JP, KR, SG.
- (84) Designated States (regional): European patent (AT, BE, CH, CY, DE, DK, ES, FI, FR, GB, GR, IE, IT, LU, MC, NL, PT, SE).
- Published: — With international search report.
- For two-letter codes and other abbreviations, refer to the "Guidance Notes on Codes and Abbreviations" appearing at the beginning of each regular issue of the PCT Gazette.

(54) Title: CHEMICAL MECHANICAL PLANARIZATION OR POLISHING PAD WITH SECTIONS HAVING VARIED GROOVE PATTERNS

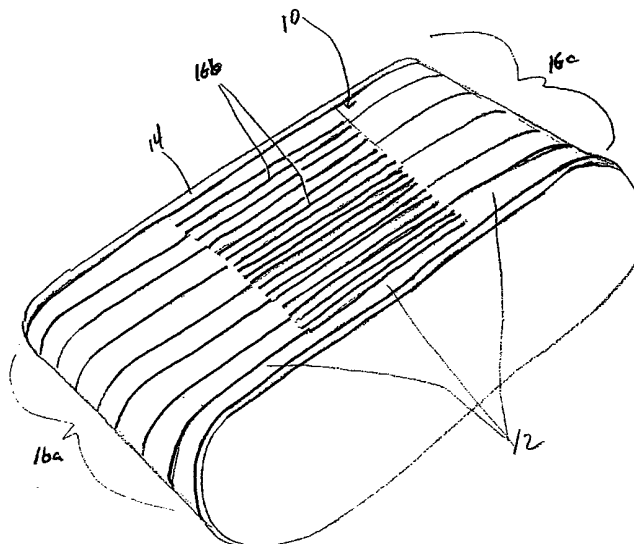

(57) Abstract: A CMP polishing pad improves overall material removal rate uniformity by combining multiple polishing pad sections (12) in a serially linked manner, where the polishing pad sections (12) are characterized by at least two different material removal rate profiles. The polishing pad (10) is designed by determining a wafer polishing profile for each of a group of polishing pads where each polishing pad has a unique groove configuration, determining a combination of polishing pad segments, each of the segments constructed with one of the unique groove configurations, that will combine to achieve an improved uniformity in the polishing profile, and manufacturing a polishing pad (10) having pad sections corresponding to the analytically determined pad sections (12).



WO 00/71297 A1

CHEMICAL MECHANICAL PLANARIZATION OR POLISHING PAD WITH SECTIONS HAVING VARIED GROOVE PATTERNS

FIELD OF THE INVENTION

5 The present invention relates to a polishing pad for use in chemical mechanical planarization applications. More particularly, the present invention relates to a pad used in the chemical mechanical planarization or polishing of semiconductor wafers.

BACKGROUND OF THE INVENTION

10 Semiconductor wafers are typically fabricated with multiple copies of a desired integrated circuit design that will later be separated and made into individual chips. A common technique for forming the circuitry on a semiconductor is photolithography. Part of the photolithography process requires that a special camera focus on the wafer to project an image of the circuit on the wafer. The ability of the camera to focus on the surface of the wafer is often adversely affected by
15 inconsistencies or unevenness in the wafer surface. This sensitivity is accentuated with the current drive toward smaller, more highly integrated circuit designs. Semiconductor wafers are also commonly constructed in layers, where a portion of a circuit is created on a first level and conductive vias are made to connect up to the next level of the circuit. After each layer of the circuit is etched on the wafer, an
20 oxide layer is put down allowing the vias to pass through but covering the rest of the previous circuit level. Each layer of the circuit can create or add unevenness to the wafer that is preferably smoothed out before generating the next circuit layer.

25 Chemical mechanical planarization (CMP) techniques are used to planarize the raw wafer and each layer of material added thereafter. Available CMP systems, commonly called wafer polishers, often use a rotating wafer holder that brings the wafer into contact with a polishing pad moving in the plane of the wafer surface to be planarized. A polishing fluid, such as a chemical polishing agent or slurry containing microabrasives, is applied to the polishing pad to polish the wafer. The wafer holder

then presses the wafer against the rotating polishing pad and is rotated to polish and planarize the wafer.

The type of polishing pad used on the wafer polisher can greatly affect the removal rate profile across a semiconductor wafer. Ideally, a semiconductor wafer processed in a wafer polisher will see a constant removal rate across the entire wafer surface. Many polishing pads have been designed with one particular pattern of channels or voids to attempt to achieve a desired removal rate. These existing polishing pads often have a signature removal rate pattern that, for example, may remove material from the edge of a semiconductor wafer faster than the inner portion of the wafer. Accordingly, there is a need for a polishing pad that will enhance uniformity across the surface of a semiconductor wafer.

SUMMARY OF THE INVENTION

According to a first aspect of the present invention, a polishing member is provided having a linear belt movable in a linear path. At least two serially linked polishing pad sections are attached to the belt. The polishing pad sections include a first polishing pad section having a first groove pattern formed in a side of the first polishing pad section. The first groove pattern is preferably made up of a plurality of grooves. A second polishing pad section has a non-grooved side opposite the linear belt.

According to a second aspect of the present invention, a polishing pad for chemical mechanical planarization of semiconductor wafers includes a plurality of serially linked polishing pad sections forming a linear belt. The plurality of serially linked polishing pad sections includes first and second polishing pad sections having respective first and second groove patterns. In one embodiment, each of the groove patterns is preferably oriented parallel to the linear path of the pad. In another embodiment, the pad sections may have non-parallel grooves.

According to another aspect of the present invention, a method of producing a linear chemical mechanical planarization polishing pad having a plurality of polishing

pad sections includes the step of empirically measuring the material removal rate profile on a semiconductor wafer for each of a plurality of groove patterns used in chemical mechanical planarization polishing pads, wherein each of the plurality of groove patterns is a unique groove pattern. The measured material removal rate profile for each of the plurality of groove patterns is then compared and a determination is made as to an appropriate combination of the different groove patterns to achieve improved removal rate uniformity across a semiconductor wafer. After determining the necessary combination, a polishing pad comprised of at least two serially linked polishing pad sections is fabricated, where at least two of the polishing pad sections include a different one of the selected groove patterns.

BRIEF DESCRIPTION OF THE DRAWINGS

FIG. 1 is a perspective view of a polishing member having a polishing pad according to a preferred embodiment of the present invention.

FIG. 2 is a partial plan view of an alternative embodiment of the polishing pad of FIG. 1.

FIG. 3 is a cross-sectional view of a grooved polishing pad section suitable for use in the polishing pad of FIGS. 1 or 2.

FIG. 4 is a partial plan view of a second alternative embodiment of the polishing pad of FIG. 1.

FIG. 5 is a plan view of a rotary polishing pad according to a preferred embodiment.

FIG. 6 is a graphical representation of material removal rate measurements made according to a preferred embodiment of the method of the present invention.

FIG. 7 is a graphical representation of the material removal rates obtained by combining selected polishing pad sections described in FIG. 4 according to a preferred embodiment.

DETAILED DESCRIPTION OF THE PRESENTLY PREFERRED EMBODIMENTS

One important factor in a chemical mechanical planarization (CMP) process is the uniformity of the resulting polish across the surface of a semiconductor wafer. By leaving uniform material thickness at all points on the wafer after completion of the polishing process, an integrated circuit die on the wafer will be more likely to maintain the same performance characteristics independent of where it originated on the wafer. As set forth below, a CMP polishing pad according to an embodiment of the present invention provides improved uniformity in removal rates and can lead to improved manufacturing process control and increased wafer yield.

FIG. 1 illustrates a presently preferred embodiment of a CMP polishing pad according to the present invention. The polishing pad includes a plurality of polishing pad sections positioned adjacent to the next so that the sections form an unbroken, serially linked chain on the supporting linear belt. Each polishing pad section is formed with its own respective groove pattern. Also, each groove pattern is arranged parallel to the direction of motion of the linear belt. Each pad section may be constructed from a separate piece of pad material and connected together to form the complete polishing pad. Alternatively, the polishing pad sections may be manufactured in a single piece of material. The polishing pad sections may either be mounted on a separate belt, as shown in FIG. 1, or may form a polishing pad that is a stand-alone belt.

Referring to FIG. 2, an alternative embodiment is shown where the polishing pad includes sections having groove patterns and a section completely lacking grooves (i.e. an unbroken polishing pad surface). Again, the grooves are arranged parallel to the direction of motion of the linear belt. Each groove pattern, in one preferred embodiment, is defined by a width, a depth, and a pitch.

As illustrated in FIG. 3, the width 18 of a groove 19 is the distance between opposing parallel walls of the groove. The depth 20 is the distance from the outer surface of the polishing pad to the bottom of the groove, and the pitch 22 is the distance from a first wall of a first groove to a respective first wall of the immediately adjacent groove. In the embodiments of FIGS. 1 -3, the groove pattern differs between pad sections but is preferably uniform within a given pad section 12, 112 so that the width, depth and pitch are the same for grooves within a particular pad section. In other embodiments, the groove pattern within a particular pad section may include a width, depth, and pitch that varies between grooves in that pad section. Additionally, while the grooves are preferably formed having a rectilinear cross-section, the grooves may be formed having slanted or curved walls. For purposes of this specification, a groove is defined as a channel that is cut or formed in the pad material where the length of the channel is greater than its width. A groove may or may not extend the entire length of a pad section.

In other embodiments of linear semiconductor polishing or planarization pads, the grooves in a particular pad section may be non-parallel. Referring to the embodiment of FIG. 4, a linear polishing pad 210 is shown including a polishing pad section 212 with a non-parallel groove pattern 216a. The non-parallel groove pattern 216a may have grooves that intersect. The polishing pad section 212 with the non-parallel groove pattern 216a may be combined with other polishing pad sections 212 having parallel groove patterns 216b – 216d. Other combinations, such as a polishing pad with all pad sections having a different, non-parallel groove pattern or a polishing pad with some pad sections having non-parallel grooves and other pad sections having non-grooved surfaces, are contemplated. As shown in the embodiment of FIG. 4, the parallel groove pattern may include pattern of serpentine grooves 216d or other curves that are disposed in either a parallel or a non-parallel relationship to each other. One or more polishing pad sections may have an embossed pattern of circular

voids or dimples formed in the pad material, rather than grooves, in yet another embodiment.

According to another embodiment, the semiconductor polishing pad may be a rotary polishing pad. FIG. 5 illustrates one rotary polishing pad 310 having a plurality of wedge-shaped sections 312 that are serially linked such that a semiconductor wafer is sequentially presented with a different section as the rotary polishing pad is rotated. Each section 312 preferably has a different groove pattern 316a – 316c. In one embodiment, one or more sections 312 may each have a groove pattern that includes a plurality of concentric arc segments (see groove patterns 316a and 316c) centered about the center of the rotary pad. In other embodiments, one or more sections 312 may have a groove pattern including a plurality of non-concentric groove patterns.

One suitable pad material for use in constructing the polishing pad sections that make up the linear or rotary semiconductor polishing pad is a closed cell polyurethane such as IC1000 available from Rodel Corporation of Phoenix, Arizona. Although each pad section is preferably constructed of the same pad material, in other embodiments, one or more different pad materials may be used for each polishing pad section in the polishing pad. The pad materials may also be selected to have a different hardnesses or densities. In one preferred embodiment, the pad materials may have a Durometer hardness in the range of 50 – 70, a compressibility in the range of 4% - 16%, and a specific gravity in the range of 0.74 – 0.85. The grooves may be fabricated in the pad material using standard techniques used by any of a number of commercial semiconductor wafer polishing pad manufacturers such as Rodel Corp.

Referring to FIGS. 1, 2 and 4, the polishing pad 10, 110, 210 may be mounted to a linear belt 14, 114 in one embodiment and utilized in a linear semiconductor wafer polisher such as the TERES™ polisher available from Lam Research Corporation of Fremont, California. In operation, the pad 10, 110, 210 is continuously moved along a linear direction while a semiconductor wafer holder (not

shown) presses a semiconductor wafer against the surface of the pad. The semiconductor wafer holder may also rotate the wafer while holding the wafer against the pad.

5 The pad 10, 110, 210, along with a slurry that is both chemically active and abrasive to the wafer surface, is used to polish layers on the wafer. Any of a number of known polishing slurries may be used. One suitable slurry is SS25 available from Cabot Corp. The groove pattern 16, 116, 216 including the absence grooves, on a pad section changes the ability of the pad to transport slurry underneath the wafer and therefore the groove pattern can affect the material removal rate profile as measured
10 on a cross section of a wafer.

One preferred method for creating a linear CMP polishing pad having a substantially uniform material removal rate profile for a semiconductor wafer is described below. First, several polishing pads, each having a single groove pattern and each completely covering the circumference of a different belt, are each used to
15 polish a semiconductor wafer for a predetermined time. The same wafer polisher, preferably the TERES™ polisher available from Lam Research Corporation, is used to test each of the polishing pads. After polishing a semiconductor wafer with a particular polishing pad, the amount of material removed is measured at various points across the diameter of the wafer and recorded in a database on a computer.
20 The removal rates are then compared at the respective measurement points used for each semiconductor wafer. Using the comparison data, a determination is made as to what combination of groove patterns, and what length of each particular groove pattern, is predicted to produce a uniform material removal rate across an entire semiconductor wafer. In one preferred embodiment, the comparison of the material
25 removal rates and determination of the appropriate combination of groove patterns may be accomplished using a personal computer running a program written in Excel by Microsoft Corporation.

After calculating the predicted polishing pad sections that produce a polishing pad having a substantially uniform material removal rate across an entire wafer, a polishing pad is fabricated using commonly known fabrication techniques so that the appropriate section lengths for each chosen groove pattern are combined on a single belt. In one embodiment, where a single pad material is used, the pad may be a single, continuous strip having the appropriate groove patterns and lengths formed in it. In another embodiment, separate pieces of pad material, each having its own groove pattern, may be linked together on a single belt.

A graphical representation of material removal rates for various groove patterns is illustrated in FIG. 6. The x-axis of the graph in FIG. 6 represents the measurement point along the diameter of the semiconductor wafer in millimeters from the center of the wafer. The y-axis represents the measured removal rate in angstroms per minute. Each trace on the graph represents the measured removal rate for a pad having a particular groove pattern. The downforce (pressure applied to the semiconductor against the pad) for all measurements was 5 pounds per square inch, while the linear speed of the pad and the rotational speed of the wafer holder were 400 feet per minute and 20 revolutions per minute, respectively. Beginning with the uppermost trace in FIG. 6, the groove patterns corresponding to the illustrated material removal rates are as follows:

Reference Number	Groove Pattern (width x depth x pitch) (all in thousandths of an inch)
200	K-Groove TM
202	10 x 20 x 40
204	10 x 20 x 100
206	20 x 20 x 50
208	10 x 10 x 100
210	20 x 20 x 40
212	10 x 20 x 50

214	20 x 20 x 100
216	No Grooves In Pad

As is apparent from the example of FIG. 6, the material removal rate and the removal rate profile vary significantly between the different groove patterns. By selecting several groove patterns and calculating a weighted average of removal rates at each point along the diameter of the wafer, where the weighting is based on the percentage of length of the complete pad that will be constructed from a pad section having the particular groove pattern, a predicted removal rate profile may be calculated. In a preferred embodiment, the grooves are oriented parallel to the direction of motion of the pad on the linear belt. While various other groove dimensions are contemplated, the groove dimensions are preferably within the range of 0-30 thousandths of an inch (mils) wide, 5-30 mils deep, and have a pitch in the range of 25-200 mils. The K-Groove™ trace 200 refers to a commercially available groove pattern from Rodel Corp.

FIG. 7 illustrates a predicted removal rate profile 218 and the actual removal rate profile 220 measured from a polishing pad fabricated according to the method described above. The polishing pad used to generate the removal rate profiles 218, 220 included three polishing pad sections having equal lengths and constructed out of the same polishing pad material. The first polishing pad section included a groove pattern of 0.010" x 0.020" x 0.100" (depth x width x pitch), the second polishing section included a groove pattern of 0.020" x 0.020" x 0.050", and the third polishing pad section had no grooves. Another polishing pad, fabricated according to a preferred embodiment of the present invention, having improved material removal rate uniformity along the entire width of the wafer, is made up of five polishing pad sections: no groove, 12 x 20 x 50, 20 x 20 x 50, 10 x 20 x 100, and 20 x 20 x 100 (where the dimensions are in thousandths of an inch and refer to width x depth x pitch).

From the foregoing, a polishing pad and a method of making the same have been described. The method takes advantage of the different material removal rate profiles of different groove patterns and optimizes a combination of the available groove patterns to form a composite pad having at least two polishing pad sections with different groove patterns. The method provides for comparing removal rate profiles for different groove patterns and mathematically optimizing a resulting combination of polishing pad sections on a single platform to improve the removal rate profile. The resulting pad preferably has a more uniform material removal rate across a semiconductor wafer.

A CMP polishing pad is also disclosed having a plurality of serially linked polishing pad sections. The plurality of pad sections may form a linear belt or may be mounted on a separate linear belt. Also, the pad sections may form a rotary polishing pad. Each polishing pad section includes a different groove pattern that, in a first embodiment, is made up of grooves oriented parallel to the direction of travel of the pad and, in another embodiment, may include grooves that are not parallel to the direction of travel.

It is intended that the foregoing detailed description be regarded as illustrative rather than limiting, and that it be understood that the following claims, including all equivalents, are intended to define the scope of this invention.

We Claim:

1. A polishing member for use in chemical mechanical planarization of semiconductor wafers, the polishing member comprising:
5 a linear belt, the linear belt movable in a linear path; and
at least two serially linked polishing pad sections attached to the belt, the polishing pad sections comprising:
10 a first polishing pad section having a first groove pattern formed in a side of the first polishing pad section opposite the linear belt, wherein the first groove pattern comprises a plurality of grooves; and
a second polishing pad section having a non-grooved side opposite the linear belt.
2. The polishing member of claim 1, wherein the plurality of grooves are
15 oriented parallel to the linear path of the linear belt.
3. The polishing member of claim 1, wherein the at least two polishing pad sections further comprise a third polishing pad section having a third groove pattern, the third groove pattern having a plurality of grooves oriented parallel to the linear path
20 of the linear belt, and wherein the third groove pattern differs from the first groove pattern.
4. The polishing member of claim 3, wherein the at least two polishing pad sections comprise at least two different levels of hardness.
25
5. The polishing member of claim 3, wherein each of the at least two polishing pad sections comprise at least two different densities.

6. The polishing member of claim 1, wherein the at least two polishing pad sections comprise at least two different material removal profiles, and wherein the serially linked polishing pad sections are configured to produce a polishing member having a substantially uniform material removal profile.

5

7. The polishing member of claim 6, wherein each of the first plurality of grooves comprises:

a rectangular cross-section having a depth defined by a distance from the surface of the first polishing pad section, a width defined by a distance perpendicular to the depth measured from a first groove wall to a second groove wall, and a pitch spacing defined by a distance between the first groove wall of a first groove in the first plurality of grooves and a respective first wall of a groove immediately adjacent to the first groove.

10

8. A polishing pad for use in chemical mechanical planarization of semiconductor wafers, the polishing pad comprising:

a plurality of serially linked polishing pad sections forming a linear belt movable in a linear path, the plurality of serially linked polishing pad sections comprising:

20

a first polishing pad section having a first groove pattern formed in a surface of the first polishing pad section; and

a second polishing pad section having a second groove pattern formed in a surface of the second polishing pad section, wherein the second groove pattern is different than the first groove pattern.

25

9. The polishing pad of claim 8, wherein the first groove pattern comprises a first plurality of grooves oriented parallel to the linear path of the linear belt.

10. The polishing pad of claim 9, wherein the second groove pattern comprises a second plurality of grooves and the second plurality of grooves are oriented parallel to the linear path of the linear belt.

5 11. The polishing member of claim 8, wherein plurality of polishing pad sections further comprises a third polishing pad section having a third groove pattern having a plurality of grooves oriented parallel to the linear path of the linear belt, and wherein the third groove pattern differs from the first and second groove patterns.

10 12. The polishing member of claim 8, wherein the first and second pad sections are characterized by different material removal rate profiles, and wherein the serially linked plurality of polishing pad sections are configured to produce a polishing member having a substantially uniform material removal rate profile.

15 13. The polishing member of claim 8, wherein each of the first and second polishing pad sections differ in hardness.

14. The polishing member of claim 8, wherein each of the first and second polishing pad sections differ in density.

20 15. The polishing member of claim 8, wherein the first polishing pad section comprises a length equal to a length of the second polishing pad section

25 16. The polishing pad member of claim 8, wherein the first polishing pad section comprises a length different than a length of the second polishing pad section.

17. The polishing pad member of claim 8, wherein at least one of the depth, the width, and the pitch of the grooves of the first polishing pad section differs from a respective depth, width, and pitch of the grooves of the second polishing pad section.

5 18. The polishing pad member of claim 8, wherein the pitch of the grooves is uniform across the first polishing pad section.

19. The polishing pad member of claim 8, wherein the pitch of the grooves varies across the first polishing pad section.

10

20. A method of producing a linear chemical mechanical planarization polishing pad having a plurality of polishing pad sections, the method comprising:

(a) measuring a material removal rate profile for each of a plurality of groove patterns used in chemical mechanical planarization polishing pads;

15 (b) determining a combination of at least two of the plurality of groove patterns based on the measured removal rate profiles of (a) that provide a substantially uniform material removal rate; and

(c) fabricating a polishing pad comprising a plurality of linked polishing pad sections, wherein the polishing pad sections comprise a combination of groove patterns determined in (b) to provide a substantially uniform material removal rate profile on the semiconductor wafer.

20

21. The method of claim 20, wherein the polishing pad is a linear polishing pad and each of the plurality of groove patterns comprises a groove pattern oriented parallel to a linear path of polishing pad.

25

22. The method of claim 20, wherein the step of measuring the material removal rate profile on the semiconductor wafer comprises, for each of the groove patterns, measuring a difference between a starting thickness and an ending thickness of the semiconductor wafer at a plurality of points along a diameter of the wafer after
5 planarizing the wafer with a polishing pad having a selected one of the plurality of groove patterns.

23. The polishing member of claim 8, wherein the plurality of polishing pad sections further comprises a third polishing pad section having a third groove pattern
10 having a plurality of grooves oriented in a non-parallel manner with respect to the linear path of the linear belt.

24. A polishing pad for chemical mechanical planarization of a semiconductor wafers, the polishing pad comprising:

15 at least two serially linked polishing pad sections formed of an abrasive material, the polishing pad sections having:

a first polishing pad section having a first groove pattern formed in a side of the first polishing pad section adapted to contact the semiconductor wafer, wherein the first groove pattern comprises a plurality of grooves ; and

20 a second polishing pad section having a second plurality of grooves in a side of the second polishing pad section adapted to contact the semiconductor wafer, wherein the first groove pattern differs from the second groove pattern.

25. The polishing pad of claim 24, wherein the first groove pattern comprises a
25 plurality of non-parallel grooves formed in the abrasive material.

26. The polishing pad of claim 25, wherein the second groove pattern comprises a plurality of parallel grooves formed in the abrasive material.

27. The polishing pad of claim 24, wherein the polishing pad comprises a linear polishing pad.

5 28. The polishing pad of claim 24, wherein the polishing pad comprises a rotary polishing pad and wherein each polishing pad section comprises a wedge-shaped section.

10 29. The polishing pad of claim 24, wherein the first groove section comprises a plurality of grooves formed in the abrasive material, the plurality of grooves having a constant width and a constant depth.

30. The polishing pad of claim 29 wherein each of the plurality of grooves further comprises a constant spacing between adjacent grooves.

15

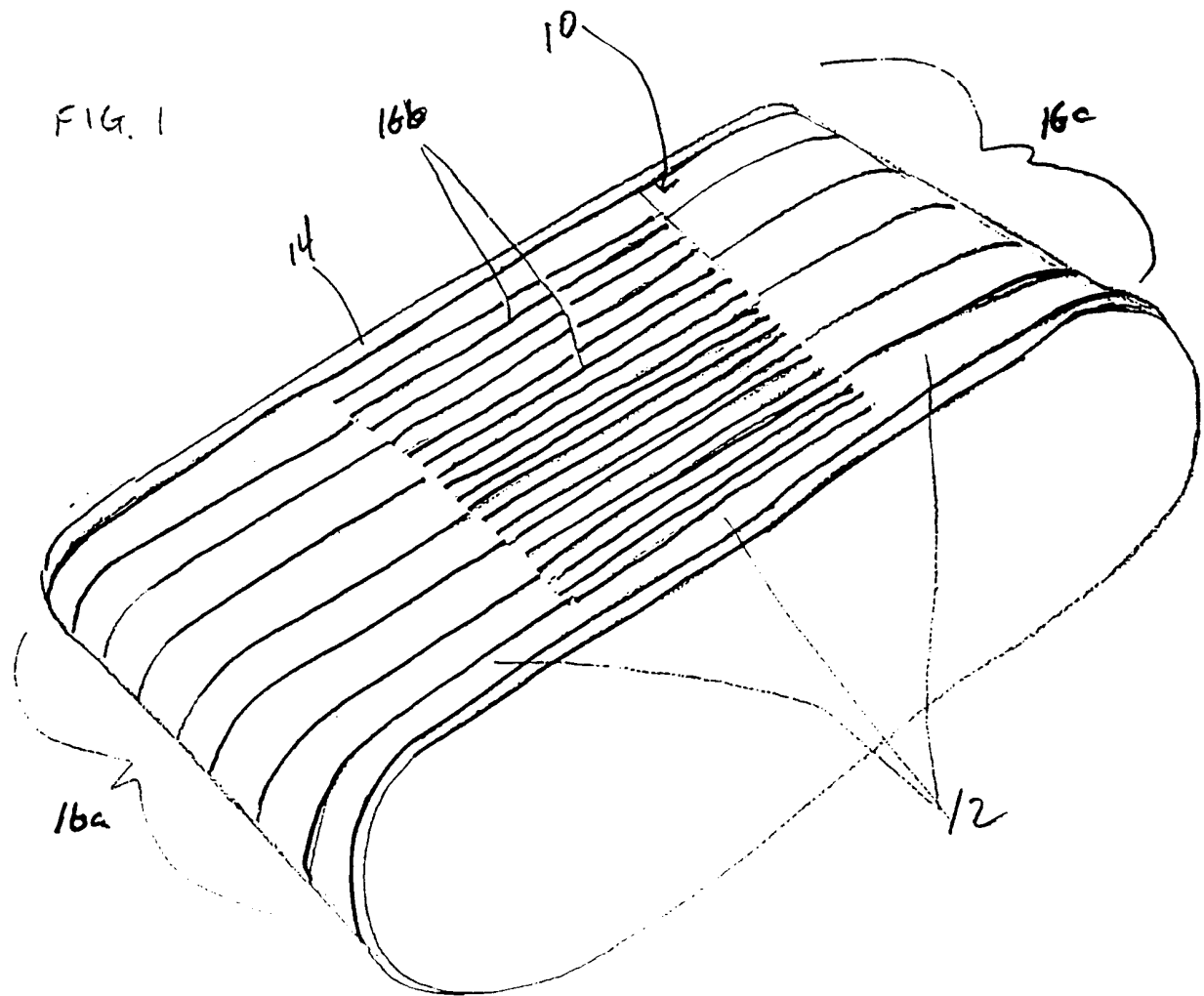

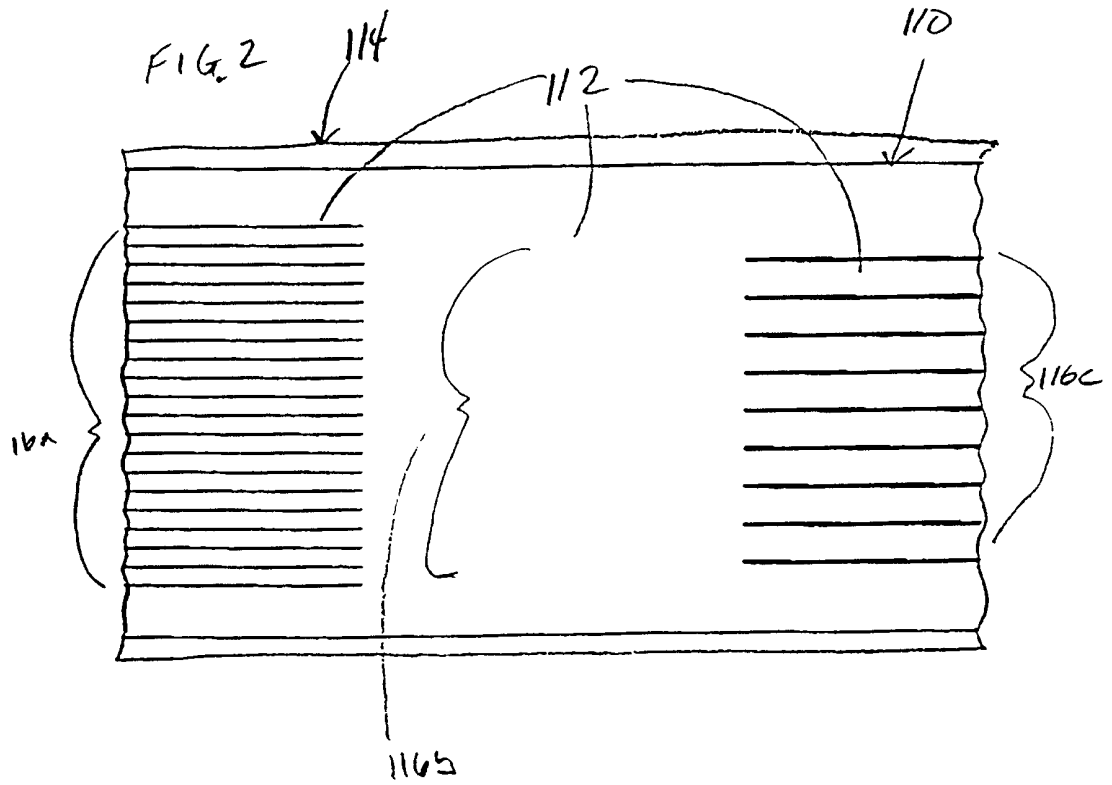
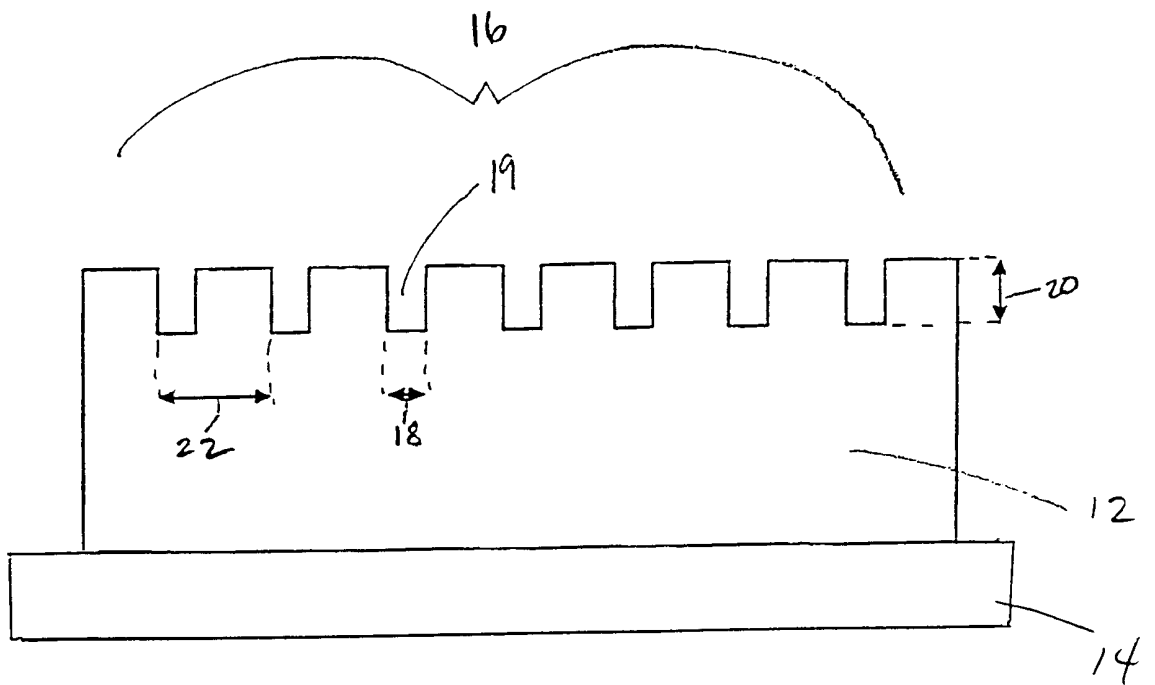

FIG. 3



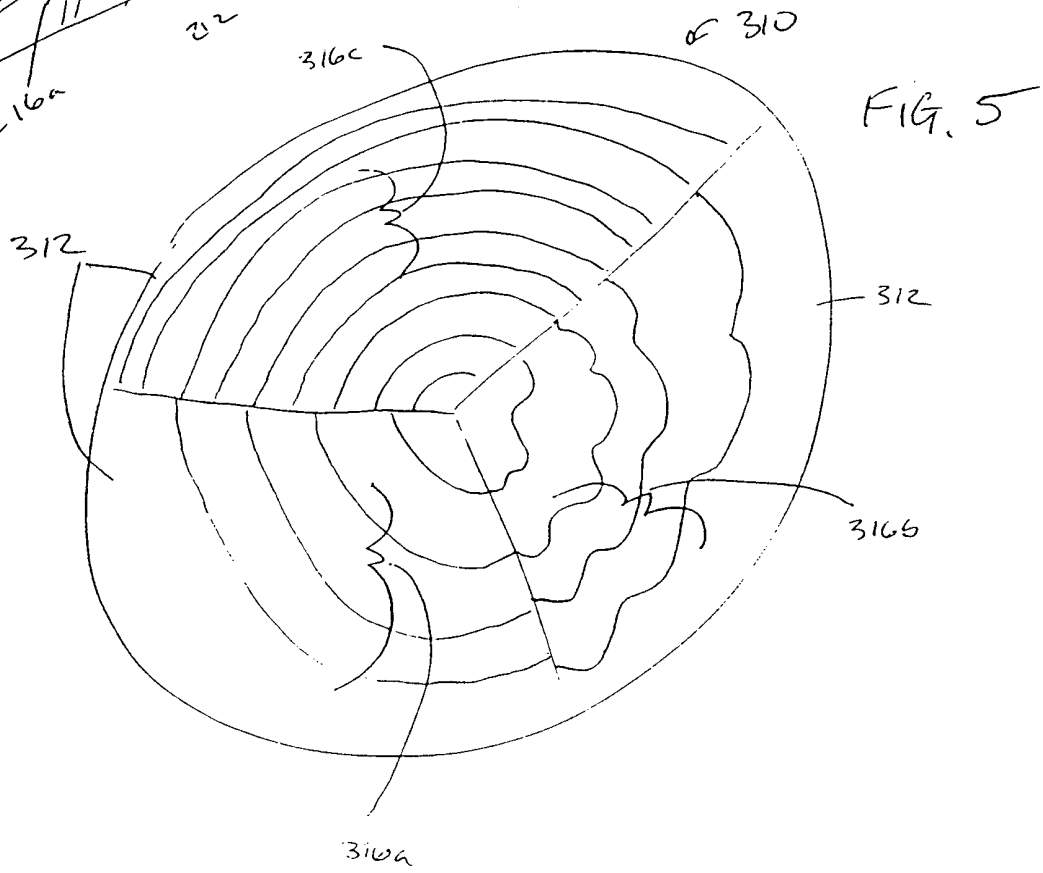
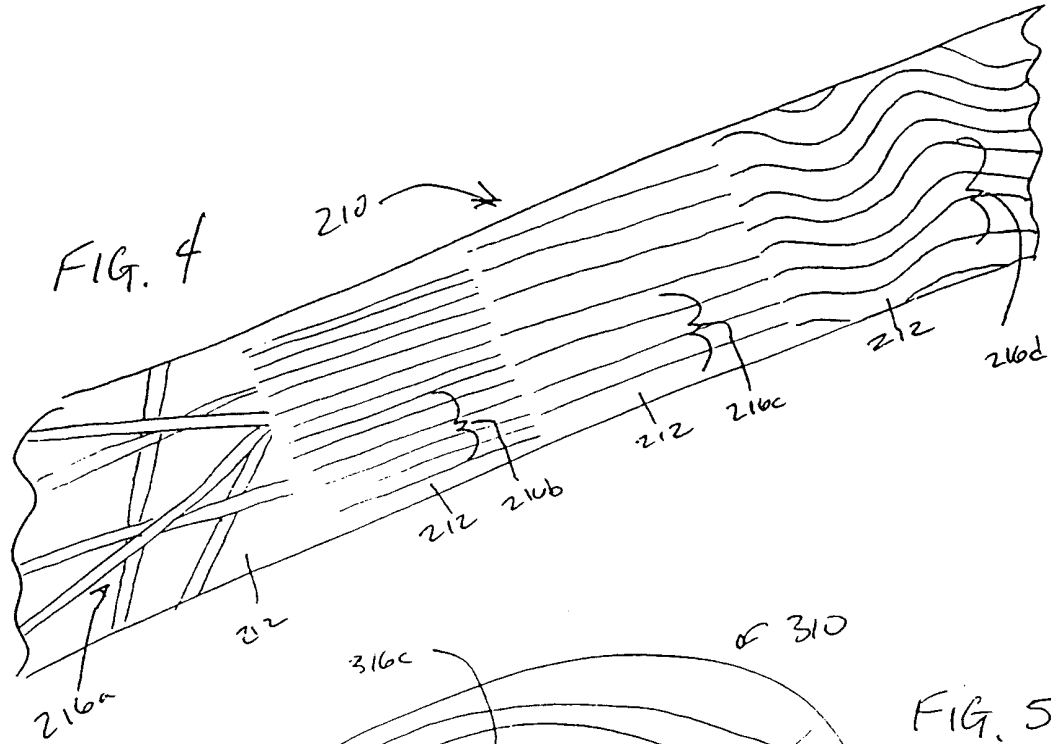

FIG. 6

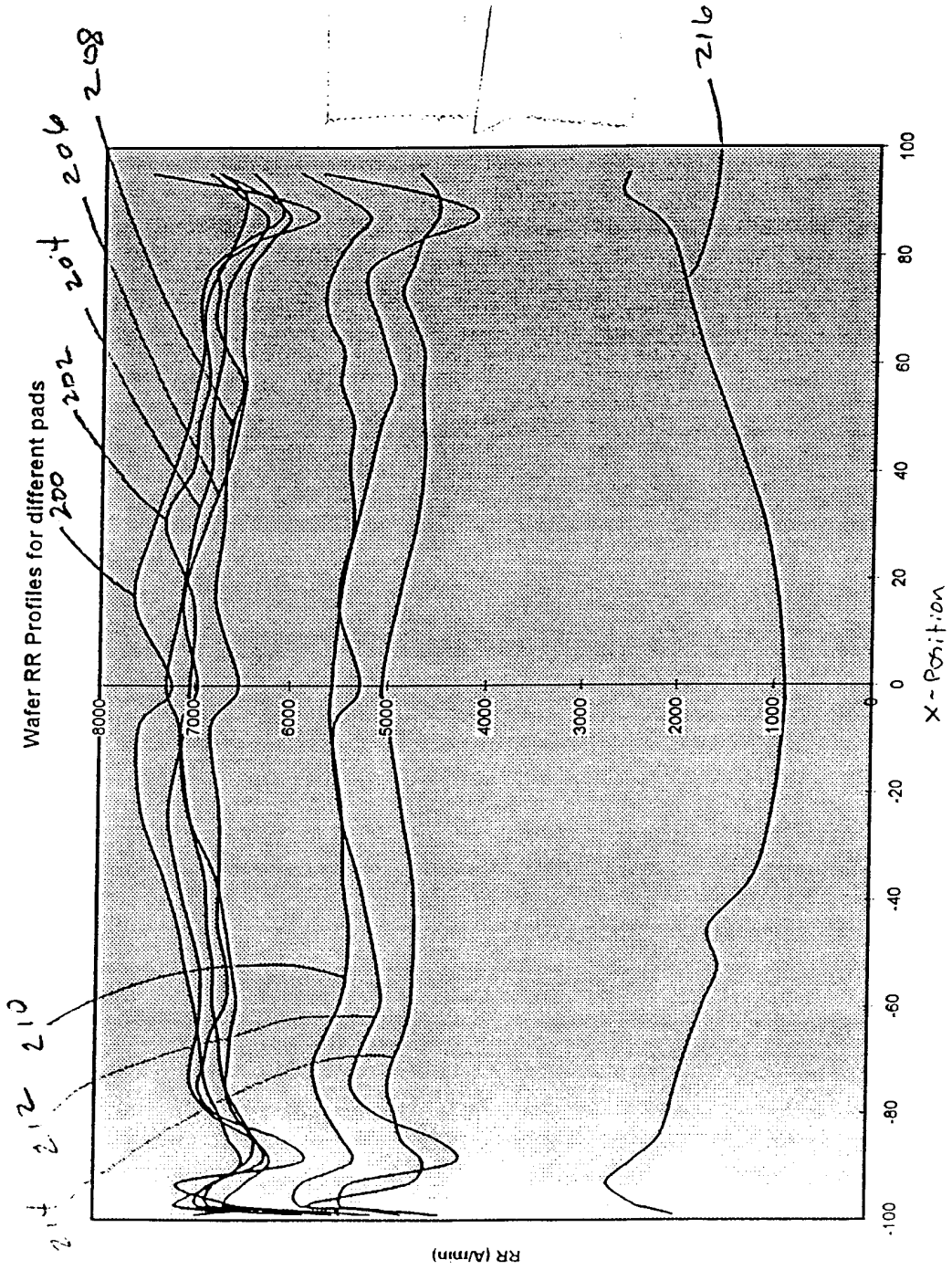
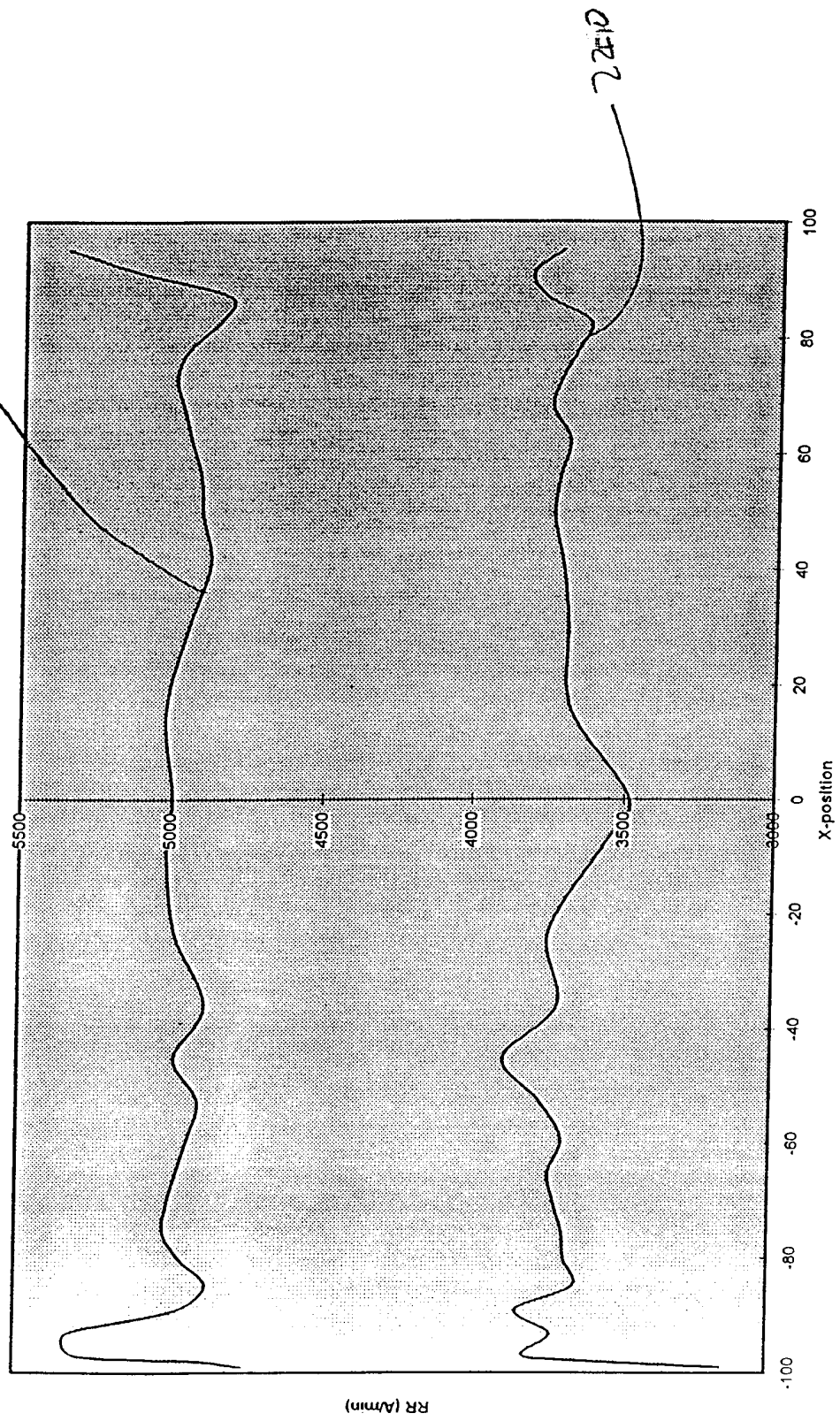

FIG. 7

Several Pads on One Belt Analysis



INTERNATIONAL SEARCH REPORT

International Application No

PCT/US 00/13328

A. CLASSIFICATION OF SUBJECT MATTER
 IPC 7 B24B37/04 B24B21/04 B24D11/04 B24D11/00

According to International Patent Classification (IPC) or to both national classification and IPC

B. FIELDS SEARCHED
 Minimum documentation searched (classification system followed by classification symbols)
 IPC 7 B24B B24D

Documentation searched other than minimum documentation to the extent that such documents are included in the fields searched

Electronic data base consulted during the international search (name of data base and, where practical, search terms used)
 EPO-Internal, PAJ, WPI Data

C. DOCUMENTS CONSIDERED TO BE RELEVANT

Category *	Citation of document, with indication, where appropriate, of the relevant passages	Relevant to claim No.
X	EP 0 878 270 A (APPLIED MATERIALS INC) 18 November 1998 (1998-11-18) column 12, line 52 -column 13, line 16; figure 15	24, 28-30
Y	---	1-23, 25-27
Y	PATENT ABSTRACTS OF JAPAN vol. 018, no. 272 (M-1610), 24 May 1994 (1994-05-24) -& JP 06 047678 A (KAWASAKI STEEL CORP; OTHERS: 03), 22 February 1994 (1994-02-22) abstract	1-23, 25-27
	---	-/--

Further documents are listed in the continuation of box C.

Patent family members are listed in annex.

* Special categories of cited documents :

- *A* document defining the general state of the art which is not considered to be of particular relevance
- *E* earlier document but published on or after the international filing date
- *L* document which may throw doubts on priority claim(s) or which is cited to establish the publication date of another citation or other special reason (as specified)
- *O* document referring to an oral disclosure, use, exhibition or other means
- *P* document published prior to the international filing date but later than the priority date claimed

- *T* later document published after the international filing date or priority date and not in conflict with the application but cited to understand the principle or theory underlying the invention
- *X* document of particular relevance; the claimed invention cannot be considered novel or cannot be considered to involve an inventive step when the document is taken alone
- *Y* document of particular relevance; the claimed invention cannot be considered to involve an inventive step when the document is combined with one or more other such documents, such combination being obvious to a person skilled in the art.
- *&* document member of the same patent family

Date of the actual completion of the international search

22 August 2000

Date of mailing of the international search report

30/08/2000

Name and mailing address of the ISA

European Patent Office, P.B. 5818 Patentlaan 2
 NL - 2280 HV Rijswijk
 Tel. (+31-70) 340-2040, Tx. 31 651 epo nl,
 Fax: (+31-70) 340-3016

Authorized officer

Garella, M

INTERNATIONAL SEARCH REPORT

International Application No

PCT/US 00/13328

C.(Continuation) DOCUMENTS CONSIDERED TO BE RELEVANT

Category *	Citation of document, with indication, where appropriate, of the relevant passages	Relevant to claim No.
A	WO 99 06182 A (SCAPA GROUP PLC ;DUDOVICZ WALTER (US); LOMBARDO BRIAN (US)) 11 February 1999 (1999-02-11) page 10, last paragraph page 12, paragraph 2 page 13, paragraph 2 -----	1,8,20, 24

INTERNATIONAL SEARCH REPORT

International Application No

PCT/US 00/13328

Patent document cited in search report	Publication date	Patent family member(s)	Publication date
EP 0878270 A	18-11-1998	US 5921855 A US 5984769 A JP 11070463 A	13-07-1999 16-11-1999 16-03-1999
JP 06047678 A	22-02-1994	NONE	
WO 9906182 A	11-02-1999	AU 8453298 A EP 0999918 A	22-02-1999 17-05-2000