

(19) World Intellectual Property Organization
International Bureau



(43) International Publication Date
9 December 2004 (09.12.2004)

PCT

(10) International Publication Number
WO 2004/107332 A1

- (51) International Patent Classification⁷: G11B 7/24, 7/0037
- (21) International Application Number: PCT/KR2004/001321
- (22) International Filing Date: 3 June 2004 (03.06.2004)
- (25) Filing Language: English
- (26) Publication Language: English
- (30) Priority Data:
10-2003-0035523 3 June 2003 (03.06.2003) KR
10-2003-0040353 20 June 2003 (20.06.2003) KR
- (71) Applicant (for all designated States except US): LG Electronics Inc. [KR/KR]; 20, Yoido-dong, Youngdungpo-gu, Seoul 150-010 (KR).
- (72) Inventors; and
- (75) Inventors/Applicants (for US only): KIM, Jin Yong [KR/KR]; 109-602, Seonkyung Apt., Yatap-dong, Bundang-gu, Seongnam, Kyunggi-do 463-928 (KR). PARK, Kyung Chan [KR/KR]; 75-201, Hyundai Apt., Apgu-jung-dong, Kangnam-gu, Seoul 135-110 (KR).
- (74) Agent: PARK, Lae Bong; 1Fl., Dongun Bldg., 413-4, Dogok 2-dong, Gangnam-gu, Seoul 135-272 (KR).
- (81) Designated States (unless otherwise indicated, for every kind of national protection available): AE, AG, AL, AM, AT, AU, AZ, BA, BB, BG, BR, BW, BY, BZ, CA, CH, CN, CO, CR, CU, CZ, DE, DK, DM, DZ, EC, EE, EG, ES, FI, GB, GD, GE, GH, GM, HR, HU, ID, IL, IN, IS, JP, KE, KG, KP, KZ, LC, LK, LR, LS, LT, LU, LV, MA, MD, MG, MK, MN, MW, MX, MZ, NA, NI, NO, NZ, OM, PG, PH, PL, PT, RO, RU, SC, SD, SE, SG, SK, SL, SY, TJ, TM, TN, TR, TT, TZ, UA, UG, US, UZ, VC, VN, YU, ZA, ZM, ZW.
- (84) Designated States (unless otherwise indicated, for every kind of regional protection available): ARIPO (BW, GH, GM, KE, LS, MW, MZ, NA, SD, SL, SZ, TZ, UG, ZM, ZW), Eurasian (AM, AZ, BY, KG, KZ, MD, RU, TJ, TM), European (AT, BE, BG, CH, CY, CZ, DE, DK, EE, ES, FI, FR, GB, GR, HU, IE, IT, LU, MC, NL, PL, PT, RO, SE, SI, SK, TR), OAPI (BF, BJ, CF, CG, CI, CM, GA, GN, GQ, GW, ML, MR, NE, SN, TD, TG).
- Published:
— with international search report

[Continued on next page]

(54) Title: HIGH-DENSITY RECORDING MEDIUM AND RECORDING AND/OR REPRODUCING DEVICE THEREFOR

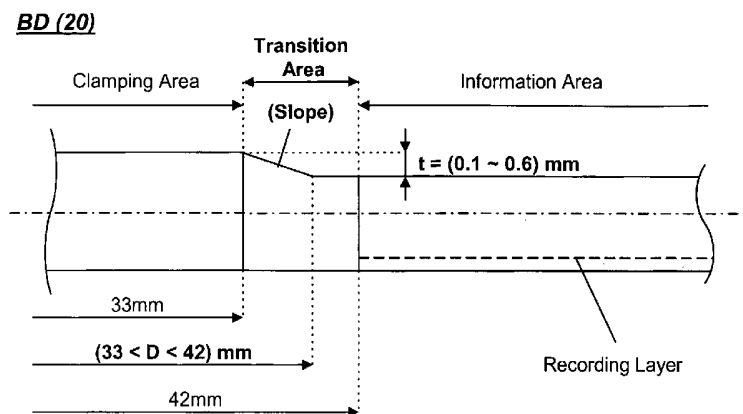

(57) Abstract: Disclosed herein are a high-density recording medium, such as a high-density optical disc and a recording and/or reproducing device therefor. At a transition area of the high-density optical disc allocated between a clamping area and an information area of the high-density optical disc is formed a step having a prescribed slope so that the high-density optical disc does not collide with an objective lens of an optical pickup provided in an optical disc device although the objective lens of the optical pickup is upwardly moved toward a recording layer of the high-density optical disc until it moves to the maximum working distance when the high-density optical disc, such as a Blu-ray disc, is improperly placed on a turntable provided in the optical disc device, e.g., when the high-density optical disc is placed upside down on the turntable. The thickness of the information area is smaller than that of the clamping area by the provision of the step at the transition area. Consequently, damage to the high-density optical disc or the objective lens due to a collision of the objective lens with the high-density optical disc is prevented, and fatal errors of a servo operation are effectively prevented. Furthermore, the cost of materials required to manufacture the high-density optical disc is reduced while stable clamping force is maintained, and safe insertion of the high-density optical disc into a slot-type optical disc drive is possible.



WO 2004/107332 A1



For two-letter codes and other abbreviations, refer to the "Guidance Notes on Codes and Abbreviations" appearing at the beginning of each regular issue of the PCT Gazette.

DESCRIPTION

HIGH-DENSITY RECORDING MEDIUM AND RECORDING AND/OR REPRODUCING DEVICE THEREFOR

5 1. Technical Field

The present invention relates to a high-density recording medium, e.g., an optical disc and a recording and/or reproducing device therefor, and more particularly to a high-density optical disc that is capable of not colliding with an objective lens of
10 an optical pickup when the high-density optical disc, such as a BD (Blu-ray disc), is improperly placed in an optical disc recording and/or reproducing device, e.g., when the high-density optical disc is placed upside down in the optical disc device, and an optical disc recording and/or reproducing device.

15

2. Background Art

As shown in Fig. 1, a general CD (compact disc) is formed with a thickness of 1.2 mm and a diameter of 120 mm. Also, the CD has a center hole of 15 mm in diameter, and a clamping area
20 of 44 mm in diameter, which is formed around the center hole. The clamping area is securely placed on a turntable provided in an optical disc device by means of a clamper also provided in the optical disc device.

A data recording layer of the CD, on which data is recorded
25 in a pit pattern, is spaced approximately 1.2 mm from the surface of the CD facing an objective lens OL of an optical pickup provided in the optical disc device. The objective lens OL, which is used in the optical pickup for the CD, has a relatively small numeral aperture NA. For example, the objective lens OL has an

NA of 0.45.

As shown in Fig. 2, a general DVD (digital versatile disc) is formed with a thickness of 1.2 mm and a diameter of 120 mm. Also, the DVD has a center hole of 15 mm in diameter, and a
5 clamping area of 44 mm in diameter, which is formed around the center hole. The clamping area is securely placed on a turntable provided in an optical disc device by means of a clamper also provided in the optical disc device.

A data recording layer of the DVD, on which data is recorded
10 in a pit pattern, is spaced approximately 0.6 mm from the surface of the DVD facing an objective lens OL of an optical pickup provided in the optical disc device. The objective lens OL, which is used in the optical pickup for the DVD, has a relatively large numeral aperture NA. For example, the objective lens OL has an
15 NA of 0.6.

As shown in Fig. 3, a high-density optical disc, standardization of which has been under discussion recently, such as a BD (Blu-ray disc), is formed with a thickness of 1.2 mm and a diameter of 120 mm. Also, the BD has a center hole of
20 15 mm in diameter, a clamping area of 33 mm in diameter, which is formed around the center hole and securely placed on a turntable provided in an optical disc device by means of a clamper also provided in the optical disc device, and a transition area of 42 mm in diameter, which is allocated between the clamping
25 area and an information area.

A data recording layer of the BD, on which data is recorded in a pit pattern, is spaced approximately 0.1 mm from the surface of the BD facing an objective lens OL of an optical pickup provided in the optical disc device.

30 The objective lens of the optical pickup for the BD has the largest numeral aperture NA. For example, the objective lens has an NA of 0.85. The optical pickup for the BD uses a laser beam having a short wavelength to reproduce data recorded in a

high-density pit pattern or record data in a high-density pit pattern, as compared to the optical pickup for the CD or the DVD.

Specifically, the laser beam having a short wavelength and the objective lens having a much larger numeral aperture are used
5 in the optical pickup for the BD. Consequently, a small spot of a laser beam having an increased amount of light can be focused on the recording layer in a state in which the objective lens of the optical pickup for the BD is closer to the recording layer of the BD. Furthermore, the light transmittance distance of the
10 laser beam having a short wavelength can be shortened, whereby property change of the laser beam and occurrence of aberration are minimized.

When a BD 10 is properly placed on a turntable 11 provided in the optical disc device, as shown in Fig. 4, a general servo
15 operation is carried out as follows. The BD 10 is rotated at high speed by means of a spindle motor 12, a motor driver 13, and a servo controller 15. While the BD 10 is rotated, the objective lens OL of an optical pickup 14, which is also provided in the optical disc device, focuses on the BD 10 based upon a
20 focusing servo operation, by which the objective lens OL of the optical pickup 14 is vertically moved within the range of a prescribed working distance WD. After the focusing servo operation is carried out, data recorded on the disc is normally read or data is normally recorded on the disc.

25 When the BD 10 is improperly placed on the turntable 11 of the optical disc device, however, for example, when the BD 10 is placed upside down on the turntable 11, as shown in Fig. 5, the recording layer of the BD 10 improperly placed on the turntable 11 is, from the objective lens OL, farther by at least
30 1.0 mm than that of the BD 10 properly placed on the turntable 11.

In this case, the objective lens OL cannot focus on the BD 10 simply by a normal focusing operation for moving the objective

lens OL vertically although the BD 10 is rotated at high speed by means of the spindle motor 12, the motor driver 13, and the servo controller 15. Consequently, the objective lens OL is upwardly moved toward the recording layer of the BD 10 until it
5 moves to the maximum working distance WD_Max under the control of the servo controller 15 for controlling the focusing servo operation. As a result, the objective lens OL comes into collision with the BD 10, which may cause the BD 10, the objective lens OL, or an actuator for supporting the objective lens OL to
10 be damaged, or otherwise cause the servo operation to have fatal errors.

3. Disclosure of Invention

Therefore, the present invention has been made in view of
15 the above problems, and it is an object of the present invention to provide a high-density optical disc that is capable of not colliding with an objective lens of an optical pickup provided in an optical disc device although the objective lens is upwardly moved toward a recording layer of the high-density optical disc
20 until it moves to the maximum working distance when the high-density optical disc, such as a BD (Blu-ray disc), is improperly placed in the optical disc device, e.g., when the high-density optical disc is placed upside down in the optical disc device, and an optical disc device therefor.

25 In accordance with one aspect of the present invention, the above and other objects can be accomplished by the provision of a high-density recording medium, comprising: a clamping area; an information area; and a transition area between the clamping area and the information area, wherein a step from top surface
30 in the transition area to the top surface in the information area is formed to have a slope down smoothly to the top surface of the information area.

In accordance with another aspect of the present invention,

there is provided a high-density recording medium, comprising:
a clamping area; an information area the thickness of which is
smaller than that of the clamping area; and a transition area
between the clamping area and the information area, wherein a
5 step is formed at the transition area, and wherein a data
recording layer is formed at a lower position with respect to
the middle of the disc in the thickness direction of the disc.

In accordance with another aspect of the present invention,
there is provided an apparatus for recording and/or reproducing
10 data on or from a high density recording medium, comprising: an
optical pickup for reading or recording data from or on a
high-density recording medium; and a servo controller
controlling the optical pickup to carry out a servo operation,
wherein the optical pickup reads or records data from or on a
15 recording layer of an information area based on the control of
the servo controller, the information area having thickness
smaller than that of a clamping area of the high-density
recording medium, wherein a transition area formed between the
clamping area and the information area, a step formed at the
20 transition area, and the recording layer formed at a lower
position with respect to half thickness of the recording medium.

In accordance with another aspect of the present invention,
there is provided an apparatus for recording and/or reproducing
data on or from a high density recording medium, comprising: an
25 optical pickup for reading or recording data from or on a
high-density recording medium, wherein the high-density
recording medium having a clamping area, an information area,
and a transition area between the clamping area and the
information area, and a step from top surface in the transition
30 area to the top surface in the information area is formed to have
a slope down smoothly to the top surface of the information area;
and a servo controller controlling the optical pickup to carry
out a servo operation to read or record data from or on a recording

layer of information area.

In accordance with yet another aspect of the present invention, there is provided a system for recording or reproducing data on or from a high-density recording medium, comprising: a high-density recording medium, the recording medium comprising a clamping area, an information area, and a transition area between the clamping area and the information area, wherein a step from top surface in the transition area to the top surface in the information area is formed to have a slope down smoothly to the top surface of the information area, and a recording layer located at a lower portion with respect to half thickness of the information area; and a recording/reproducing device which is able to insert the high-density recording medium, and operable to record or reproduce data on or from the high-density recording medium.

4. Brief Description of Drawings

The accompanying drawings, which are included to provide a further understanding of the invention, illustrate the preferred embodiments of the invention, and together with the description, serve to explain the principles of the present invention.

Fig. 1 is a view showing the disc structure of a general CD (compact disc);

Fig. 2 is a view showing the disc structure of a general DVD (digital versatile disc);

Fig. 3 is a view showing the disc structure of a general BD (Blu-ray disc);

Fig. 4 is a view showing the BD properly placed in a general optical disc device;

Fig. 5 is a view showing the BD improperly placed in the general optical disc device;

Fig. 6 is a cross-sectional view showing a high-density optical disc according to a preferred embodiment of the present

invention;

Fig. 7 is a view showing that the high-density optical disc does not collide with an objective lens by the provision of a sloping step according to the present invention;

5 Fig. 8 is a view showing the high-density optical disc according to the present invention properly placed in an optical disc device;

Fig. 9 is a view showing the high-density optical disc according to the present invention improperly placed in the
10 optical disc device; and

Figs. 10 to 15 illustrate high-density optical discs according to the present invention and results of experiments on the high-density optical discs.

Features, elements, and aspects of the invention that are
15 referenced by the same numerals in different figures represent the same, equivalent, or similar features, elements, or aspects in accordance with one or more embodiments.

5. Modes for Carrying out the Invention

20 Now, a high-density optical disc and an optical disc device for reading data recorded on such a high-density optical disc and recording data on such a high-density optical disc according to a preferred embodiment of the present invention will be described in detail with reference to the accompanying drawings.

25 Fig. 6 is a cross-sectional view showing a high-density optical disc according to a preferred embodiment of the present invention. As already described above with reference to Fig. 3, the high-density optical disc, for example, a BD (Blu-ray disc) 20 is formed with a thickness of 1.2 mm and a diameter of
30 120 mm. Also, the BD 20 has a center hole of 15 mm in diameter, a clamping area of 33 mm in diameter, which is formed around the center hole and securely placed on a turntable provided in the optical disc device by means of a clamper also provided in the

optical disc device, and a transition area of 42 mm in diameter, which is allocated between the clamping area and an information area.

A data recording layer of the BD 20, on which data is recorded in a pit pattern, is spaced approximately 0.1 mm from the surface of the BD 20 facing an objective lens of an optical pickup provided in the optical disc device. The BD 20 is formed such that the thickness of the clamping area is different from that of the information area. For example, the transition area of the BD 20 includes a sloping step having a prescribed thickness t of 0.1 to 0.6 mm at the surface of the BD 20 at a longer distance from the data recording layer of the BD 20, as shown in Fig. 6. Consequently, the thickness of the information area is 0.1 to 0.6 mm smaller than that of the clamping area.

The step is formed to prevent a collision of the objective lens of the optical pickup with the BD 20 although the objective lens is upwardly moved toward the recording layer of the BD 20 to focus on the recording layer until it moves to the maximum working distance when the BD 20 is improperly placed on the turntable of the optical disc device, e.g., when the BD 20 is placed upside down on the turntable. Specifically, the step of 0.1 to 0.6 mm in thickness is formed from the end position of the clamping area to the starting position of the information area while having a prescribed slope in order to provide a prescribed gap distance between the BD 20 and the objective lens, as shown in Fig. 6.

When a BD having a sloping step formed from the end position of the clamping area, which has a diameter of 33 mm, to the starting position of the information area, which has a diameter of 42 mm, is placed upside down in the optical disc device (Example 1), the objective lens OL of the optical pickup collides with the BD as the objective lens OL is maximally moved in the horizontal direction.

In a BD according to a preferred embodiment of the present invention, the sloping step is partially formed on the transition area. For example, the sloping step of the BD is formed from the end position of the clamping area, which has a diameter of 5 33 mm, to the position placed 2.0 mm ahead of the starting position of the information area, which has a diameter of 42 mm. Consequently, the objective lens OL of the optical pickup does not collide with the BD although the objective lens OL is maximally moved in the horizontal direction when the BD is placed 10 upside down in the optical disc device (Example 2).

The sloping step may be formed with a maximum slope length of 3.5 mm $(=(40 \text{ mm} - 33 \text{ mm})/2)$ in the radial direction of the disc on the basis of the center hole of the optical disc. Also, the sloping step may have a minimum slope length of 1.8 mm $(=(40$ 15 $\text{ mm} - 36.4 \text{ mm})/2)$ in the radial direction of the disc, considering that the clamping area may be extended above its diameter of 33 mm. It is preferable, however, that the sloping step has a minimum slope length of 1.0 mm $(=(40 \text{ mm} - 38 \text{ mm})/2)$ in consideration of manufacturing deviation of the optical disc. 20 Consequently, the sloping step preferably has a slope length of 1.0 mm to 3.5 mm in the radial direction of the disc in the embodiment of the present invention.

When the BD 20 is properly inserted into the optical disc device as shown in Fig. 8, the clamping area of the BD 20 is safely 25 placed on the turntable 11. In this case, the thickness of the clamping area is not changed, whereby stable clamping force is maintained. Furthermore, the thickness of the information area is reduced so that a relatively small centrifugal force is generated when the BD 20 is rotated at high speed, whereby more 30 stable clamping force is guaranteed.

While the BD 20 is rotated at high speed by means of the spindle motor 12, the motor driver 13, and the servo controller 15, the objective lens OL of the optical pickup 14 is vertically

moved within the range of a prescribed working distance to carry out a focusing servo operation. After the focusing servo operation is carried out, data recorded on the disc is normally read, or data is normally recorded on the disc.

5 Even when the BD 20 is improperly inserted into the optical disc device, for example, the BD 20 is inserted upside down into the optical disc device as shown in Fig. 9, the clamping area of the BD 20 is safely placed on the turntable 11. In this case, however, a gap distance of 0.1 to 0.6 mm is formed between the
10 surface of the clamping area placed on the turntable 11, facing the objective lens OL and the surface of the information area facing the objective lens OL by means of the sloping step formed at the transition area of the BD 20.

Consequently, the objective lens OL of the optical pickup
15 14 does not collide with the BD 20 although the objective lens OL of the optical pickup 14 is maximally moved in the vertical direction to carry out a focusing servo operation while the BD 20 is rotated at high speed by means of the spindle motor 12, the motor driver 13, and the servo controller 15. Furthermore,
20 the data recording layer of the BD 20 is spaced apart from the surface of the BD 20 facing the objective lens OL, whereby no normal focusing operation is carried out, and thus it is recognized that no disc is in the optical disc device.

Moreover, the maximum working distance of the objective
25 lens OL is further increased, which is advantageous to carry out the focusing servo operation. The thickness of the information area of the BD 20 is reduced below 1.2 mm, whereby the cost of materials required to manufacture the BD 20 is decreased. In the case that the BD 20 is manually inserted into a slot-type
30 optical disc drive, the BD 20 may collide with the optical disc drive due to the step formed at the BD 20. However, a shock due to the collision of the BD 20 with the optical disc drive is minimized by means of the sloping shape of the step, whereby

smooth insertion of the BD 20 into the optical disc drive is possible.

The reason why the sloping step having a thickness of 0.1 mm to 0.6 mm is formed at the transition area of the BD will now be described. As shown in Fig. 10, the maximum thickness of the clamping area of the BD is 1.3 mm. Consequently, the thickness of an injection-molded substrate is 1.2 mm with the exception of a cover layer of 0.1 mm in thickness.

When the step is formed on the surface of the BD opposite to the cover layer so that the information area and the rim area are manufactured while the thickness of the information and rim area is smaller than that of the clamping area, for example, the thickness of the injection-molded substrate at the information area and the rim area is 0.6 mm, which is the same as a general DVD, a transcription property of grooves or pits formed at the recording surface during the injection molding is not deteriorated as in the DVD.

Consequently, when the thickness of the clamping area is 1.2 mm as shown in Fig. 10, the substrate at the information area and the rim area can be easily manufactured without deterioration of injection-molding and transcription properties as long as the thickness of the substrate at the information area and the rim area is 0.6 mm. As a result, the step having a thickness of up to 0.6 mm can be formed between the clamping area and the information area.

When the cover layer of 0.1 mm in thickness is formed on the recording surface of the BD, it is possible to manufacture a BD having a clamping area whose thickness is 1.3 mm, an information area whose thickness is 0.7 mm, and a rim area whose thickness is 0.7 mm. When the minimum thickness of the clamping area is 1.15 mm, and the thickness of the step is 0.6 mm, the thickness of the information area and the rim area is 0.55 mm. Consequently, the thickness of the injection-molded substrate

is 0.45 with the exception of the thickness of the cover layer, which is 0.1 mm. In this case, however, the injection-molded substrate having a thickness of 0.45 mm can be practically manufactured.

5 On the other hand, the reason why the minimum thickness of the step is set to 0.1 mm is as follows. Even when the objective lens for the BD having a numeral aperture of 0.85 has a large working distance, for example, approximately 0.5 mm or more, as shown in Fig. 11, a collision of the objective lens with the BD
10 is prevented by the provision of the step having a thickness of at least 0.1 mm. Specifically, a collision of the objective lens with the BD is effectively prevented even when the distance in which the objective lens can be vertically moved to carry out the focusing servo operation is 0.5 mm in the direction close
15 to the recording surface of the disc and 0.5 mm in the direction away from the recording surface of the disc on the basis of the focusing position. When the working distance of the objective lens is large, the effect of prevention of the collision of the objective lens with the BD is increased as the step of the BD
20 has a larger thickness. When the working distance of the objective lens is small, however, the collision of the objective lens with the BD can still be prevented although the step of the BD has a small thickness.

When the injection-molded substrate having a thickness of
25 1.1 mm/0.8 mm and the cover layer having a thickness of 100 μ m are manufactured with polycarbonate, as shown in Fig. 12, so that the thickness of the clamping area is 1.2 mm, and the thickness of the information area and the rim area is 0.9 mm, the radial angular deviation α has the maximum value ($\alpha = 0.70$ degree), which
30 is required under normal test conditions applied to the BD, i.e., a temperature of 23 ± 2 $^{\circ}$ C, a relative humidity of 45 % to 55 %, and an atmospheric pressure of 86 kPa to 106 kPa.

When the injection-molded substrate is made of

polycarbonate as shown in Fig. 13, the angular deviation ($\alpha = 0.80$ degree) is satisfied under the sudden change test conditions of the BD, i.e., a condition in which the relative humidity is changed from 95 % to 45 %, and the temperature is 25 °C, which is unchanged, and another condition in which the relative humidity is changed from 45 % to 30.0 %, and the temperature is changed from 25 °C to 70 °C while a prescribed level of the absolute humidity is maintained, as long as the thickness of the disc, i.e., the thickness of the disc in information area is at least 0.9 mm. However, it is difficult to satisfy the above-mentioned conditions when the thickness of the disc is below 0.9 mm. Consequently, it is preferable to set the minimum thickness of the disc to 0.9 mm when the injection-molded substrate is made of polycarbonate. However, it is possible to manufacture a disc having a thickness of below 0.9 mm when the injection-molded substrate is made of one of other plastic materials having higher strength than that of the polycarbonate.

When the disc is directly loaded into or unloaded from a slot-type disc drive, which has no tray, as shown in Fig. 14, the disc may be caught by the disc drive due to the vertical step formed at the disc, which leads to a failure to load the disc into the disc drive. When the disc is manufactured such that the sloping angle of the step is not more than 30 degrees (= 0.6 mm/1.0 mm) as shown in Fig. 15, however, the disc is not caught by the disc drive due to the slope provided at the step.

Although the preferred embodiments of the present invention have been disclosed for illustrative purposes, those skilled in the art will appreciate that various modifications, additions and substitutions are possible, without departing from the scope and spirit of the invention as disclosed in the accompanying claims. For example, the step formed at the transition area of the disc may have other shapes in addition to the aforesaid sloping shape.

As apparent from the above description, the present invention provides a high-density optical disc wherein a prescribed gap distance between the high-density optical disc and an objective lens of an optical pickup provided in an optical disc device is increased. Consequently, the present invention has an effect of preventing a collision of the high-density optical disc with the objective lens of the optical pickup, whereby damage to the high-density optical disc or the objective lens of the optical pickup is prevented, and fatal errors of a servo operation are effectively prevented.

CLAIMS

1. A high-density recording medium, comprising:
a clamping area;
an information area; and
5 a transition area between the clamping area and the
information area,

wherein a step from top surface in the transition area to
the top surface in the information area is formed to have a slope
down smoothly to the top surface of the information area.

10

2. The recording medium as set forth in claim 1, wherein
the transition area is located at the diameter $d_{out} < d < 42\text{mm}$,
wherein d_{out} is an outer diameter of the clamping area.

15 3. The recording medium as set forth in claim 2, wherein
the step is formed from the end position of the clamping area
to the position placed at least a predetermined diameter ahead
of the start position of the information area, the information
area being started from diameter 42mm.

20

4. The recording medium as set forth in claim 3, wherein
the predetermined diameter is 2.0 mm.

5. The recording medium as set forth in claim 1, wherein
25 a recording layer is formed at a lower position with respect to
half thickness of the recording medium.

6. The recording medium as set forth in claim 5, wherein
the high-density recording medium is a Blu-ray disc.

30

7. The recording medium as set forth in claim 5, wherein

the step is formed at a top surface of the recording medium at a longer distance from the recording layer of the recording medium.

5 8. The recording medium as set forth in claim 5, wherein the data recording layer is located at a thickness of about 0.1mm from entrance surface of the recording medium.

 9. The recording medium as set forth in claim 1, wherein
10 the step is formed from the end position of the claiming area while the end position of the clamping area is a start position of transition area.

 10. The recording medium as set forth in claim 9, wherein
15 the step between the top surface of the clamping area and the top surface of the information area has a thickness of more than 0.1mm.

 11. The recording medium as set forth in claim 9, wherein
20 the step between the top surface of the clamping area and the top surface of the information area has at least a thickness $0.1\text{mm} < t < 0.6\text{mm}$.

 12. The recording medium as set forth in claim 9, wherein
25 the step between the top surface of the clamping area and the top surface of the information area has a thickness so as not to collide with an objective lens of optical pickup to focus a data recording layer.

30 13. The recording medium as set forth in claim 9, wherein the step between the top surface of the clamping area and the top surface of the information area has a slope so as not to collide with the optical pickup when the optical pickup is moved

to inner direction of the recording medium.

14. The recording medium as set forth in claim 1, wherein the slope has a maximum radius 3.5mm.

5

15. The recording medium as set forth in claim 1, wherein the slope has a minimum radius 1.8mm.

16. The recording medium as set forth in claim 1, wherein
10 the slope has a minimum radius 1.0mm.

17. The recording medium as set forth in claim 16, wherein the slope has an angle of θ degrees when the slope has the minimum radius 1.0mm and the minimum thickness 0.1, wherein the θ is
15 $\tan^{-1}(0.1/1.0)$.

18. The recording medium as set forth in claim 1, wherein the step has a slope of max 30° .

20 19. The recording medium as set forth in claim 1, wherein the slope is formed at radius 1.0mm to 3.5mm.

20. The recording medium as set forth in claim 1, wherein the clamping area has a thickness of max 1.3mm.

25

21. The recording medium as set forth in claim 1, wherein the information area has a thickness of min 0.9mm.

22. A high-density recording medium, comprising:
30 a clamping area;
an information area the thickness of which is smaller than that of the clamping area; and

a transition area between the clamping area and the information area, wherein a step is formed at the transition area,

wherein a data recording layer is formed at a lower position
5 with respect to the middle of the disc in the thickness direction of the disc.

23. The recording medium as set forth in claim 22, wherein the step is formed from the end position of the clamping area
10 to the starting position of the information area while having a prescribed slope.

24. The recording medium as set forth in claim 23, wherein the step is formed from the end position of the clamping area
15 to the position placed at least 2.0 mm ahead of the starting position of the information area.

25. The recording medium as set forth in claim 22, wherein the step from top surface in the clamping area to the top surface
20 in the information area is formed to have a slope down smoothly to the top surface of the information area.

26. The recording medium as set forth in claim 25, wherein the step has a thickness of minimum 0.1 mm.
25

27. The recording medium as set forth in claim 25, wherein the step has a thickness of 0.1 to 0.6 mm.

28. The recording medium as set forth in claim 22, wherein
30 the high-density recording medium is a Blu-ray disc.

29. The recording medium as set forth in claim 28, wherein the data recording layer is located at a thickness of about 0.1mm

from entrance surface of the Blu-ray disc.

30. The recording medium as set forth in claim 22, wherein the step is formed at the surface of the recording medium at a longer distance from the data recording layer of the recording medium.

31. An apparatus for recording and/or reproducing data on or from a high density recording medium, comprising:

10 an optical pickup for reading or recording data from or on a high-density recording medium; and

a servo controller controlling the optical pickup to carry out a servo operation,

wherein the optical pickup reads or records data from or on a recording layer of an information area based on the control of the servo controller, the information area having thickness smaller than that of a clamping area of the high-density recording medium, wherein a transition area formed between the clamping area and the information area, a step formed at the transition area, and the recording layer formed at a lower position with respect to half thickness of the recording medium.

32. The apparatus as set forth in claim 31, wherein the servo controller extends the maximum working distance of an objective lens provided at the optical pickup to the position higher than that of the clamping area of the high-density recording medium placed in the device.

33. The apparatus as set forth in claim 31, further comprising:

a clamping unit clamping the clamping area of the recording medium by a force.

34. An apparatus for recording and/or reproducing data on or from a high density recording medium, comprising:

an optical pickup for reading or recording data from or on a high-density recording medium, wherein the high-density recording medium having a clamping area, an information area, and a transition area between the clamping area and the information area, and a step from top surface in the transition area to the top surface in the information area is formed to have a slope down smoothly to the top surface of the information area;

10 and

a servo controller controlling the optical pickup to carry out a servo operation to read or record data from or on a recording layer of information area.

15 35. The apparatus of claim 34, further comprising:

a clamping unit clamping the clamping area of the recording medium by a predetermined force.

36. The apparatus of claim 34, wherein the optical pickup includes an objective lens, and the objective lens has a working distance in vertical direction to focus the recording layer by the control of the servo controller.

20

37. The apparatus of claim 34, wherein the servo controller controls the objective lens to move in vertical direction up to maximum working distance to focus the recording layer when the recording medium is placed upside down on a turntable.

25

38. The apparatus of claim 37, wherein the servo controller does not focus the recording layer even if the objective lens is moved to the maximum working distance.

30

39. The apparatus of claim 38, wherein the servo controller

generates a signal for indicating a focus error, thereby determining that no recording medium is inserted in the apparatus.

5 40. A system for recording or reproducing data on or from a high-density recording medium, comprising:

 a high-density recording medium, the recording medium comprising a clamping area, an information area, and a transition area between the clamping area and the information area,

10 wherein a step from top surface in the transition area to the top surface in the information area is formed to have a slope down smoothly to the top surface of the information area, and a recording layer located at a lower portion with respect to half thickness of the information area; and

15 a recording/reproducing device which is able to insert the high-density recording medium, and operable to record or reproduce data on or from the high-density recording medium.

 41. The system of claim 40, wherein the recording/
20 reproducing device includes an optical pickup for reading or recording data from or on a high-density recording medium, and

 a servo controller controlling the optical pickup to carry out a servo operation to read or record data from or on a recording layer of information area.

25

 42. The system of claim 41, wherein the recording/
reproducing device further includes a clamping unit clamping the clamping area of the recording medium by a predetermined force.

30 43. The system of claim 41, wherein the optical pickup includes an objective lens, the objective lens has a working distance in vertical direction to focus the recording layer by the control of the servo controller.

44. The system of claim 41, wherein the servo controller controls the objective lens to move in vertical direction up to maximum working distance to focus the recording layer when the recording medium is placed upside down on a turntable.

45. The system of claim 44, wherein the servo controller does not focus the recording layer even if the objective lens is moved to the maximum working distance.

10

46. The system of claim 45, wherein the servo controller generates a signal for indicating a focus error, thereby determining that no recording medium is inserted in the apparatus.

15

47. The system of claim 40, wherein the transition area of the recording medium is located at the diameter $d_{out} < d < 42\text{mm}$, wherein d_{out} is an outer diameter of the clamping area.

20

48. The system of claim 47, wherein the step is formed from the end position of the clamping area to the position placed at least a predetermined diameter ahead of the start position of the information area, the information area being started from diameter 42mm.

25

49. The system of claim 48, wherein the predetermined diameter is 2.0 mm.

50. The system of claim 40, wherein the step of the recording medium is formed at a top surface of the recording medium at a longer distance from the recording layer of the recording medium.

51. The system of claim 40, wherein the data recording layer is of the recording medium located at a thickness of about 0.1mm from entrance surface of the recording medium.

5 52. The system of claim 40, the step of the recording medium is formed from the end position of the claiming area while the end position of the clamping area is a start position of transition area.

10 53. The system of claim 52, wherein the step between the top surface of the clamping area and the top surface of the information area has a thickness of more than 0.1mm.

15 54. The system of claim 52, wherein the step between the top surface of the clamping area and the top surface of the information area has at least a thickness $0.1\text{mm} < t < 0.6\text{mm}$.

20 55. The system of claim 52, wherein the step between the top surface of the clamping area and the top surface of the information area has a thickness so as not to collide with an objective lens of optical pickup to focus a data recording layer.

25 56. The system of claim 52, wherein the step between the top surface of the clamping area and the top surface of the information area has a slope so as not to collide with the optical pickup when the optical pickup is moved to inner direction of the recording medium.

30 57. The system of claim 40, wherein the slope of the recording medium has a minimum radius 1.8mm.

58. The system of claim 40, wherein the slope of the recording medium has a minimum radius 1.0mm.

59. The system of claim 58, wherein the slope has an angle of θ degrees when the slope has the minimum radius 1.0mm and the minimum thickness 0.1, wherein the θ is $\tan^{-1}(0.1/1.0)$.

5

60. The system of claim 40, wherein the slope of the recording medium is formed at radius 1.0mm to 3.5mm.

61. The system of claim 40, wherein the clamping area of
10 the recording medium has a thickness of max 1.3mm.

62. The system of claim 40, wherein the information area of the recording medium has a thickness of min 0.9mm.

FIG. 1

CD (Compact Disc)

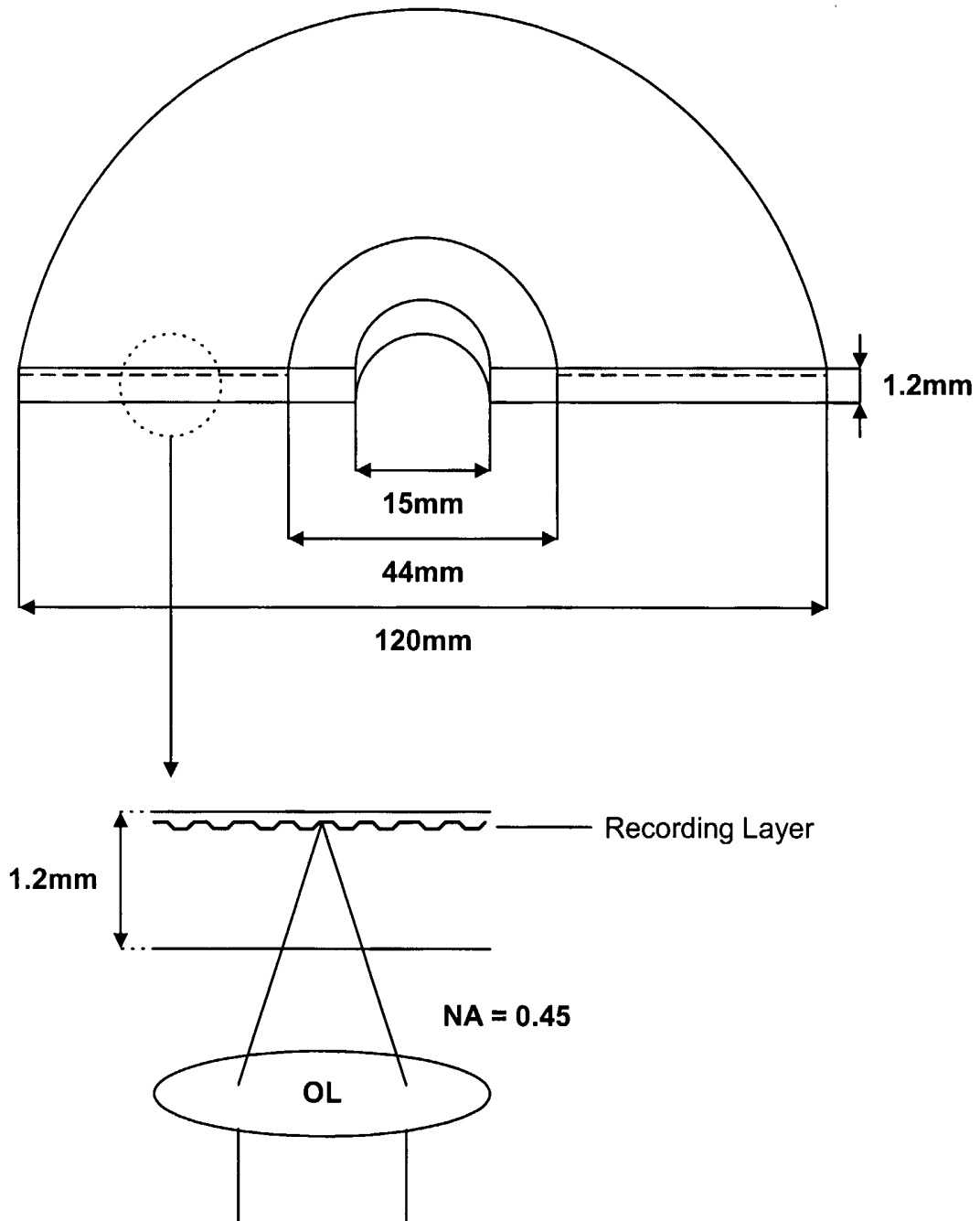

FIG. 2

DVD (Digital Versatile Disc)

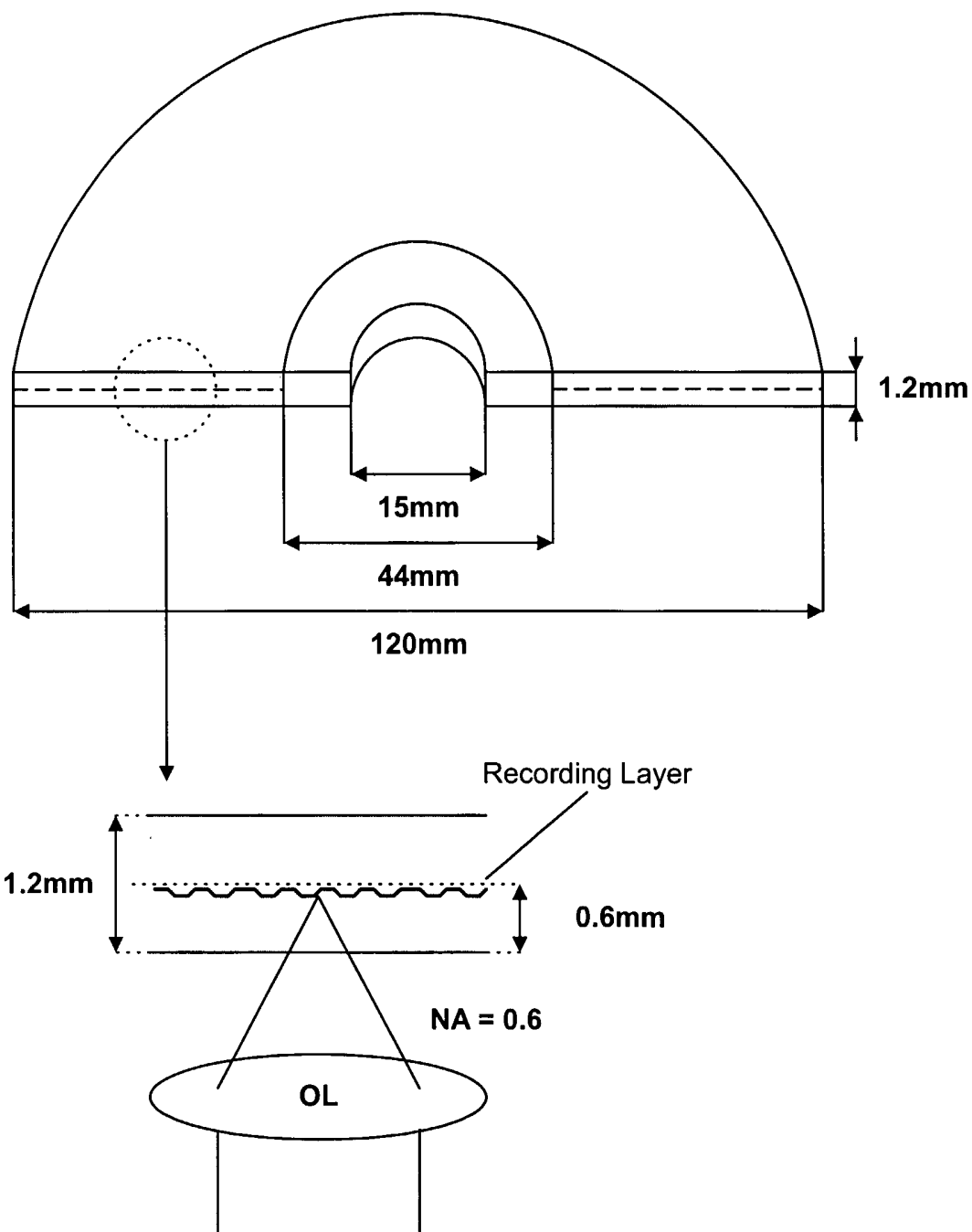

FIG. 3

BD (Blu-ray Disc)

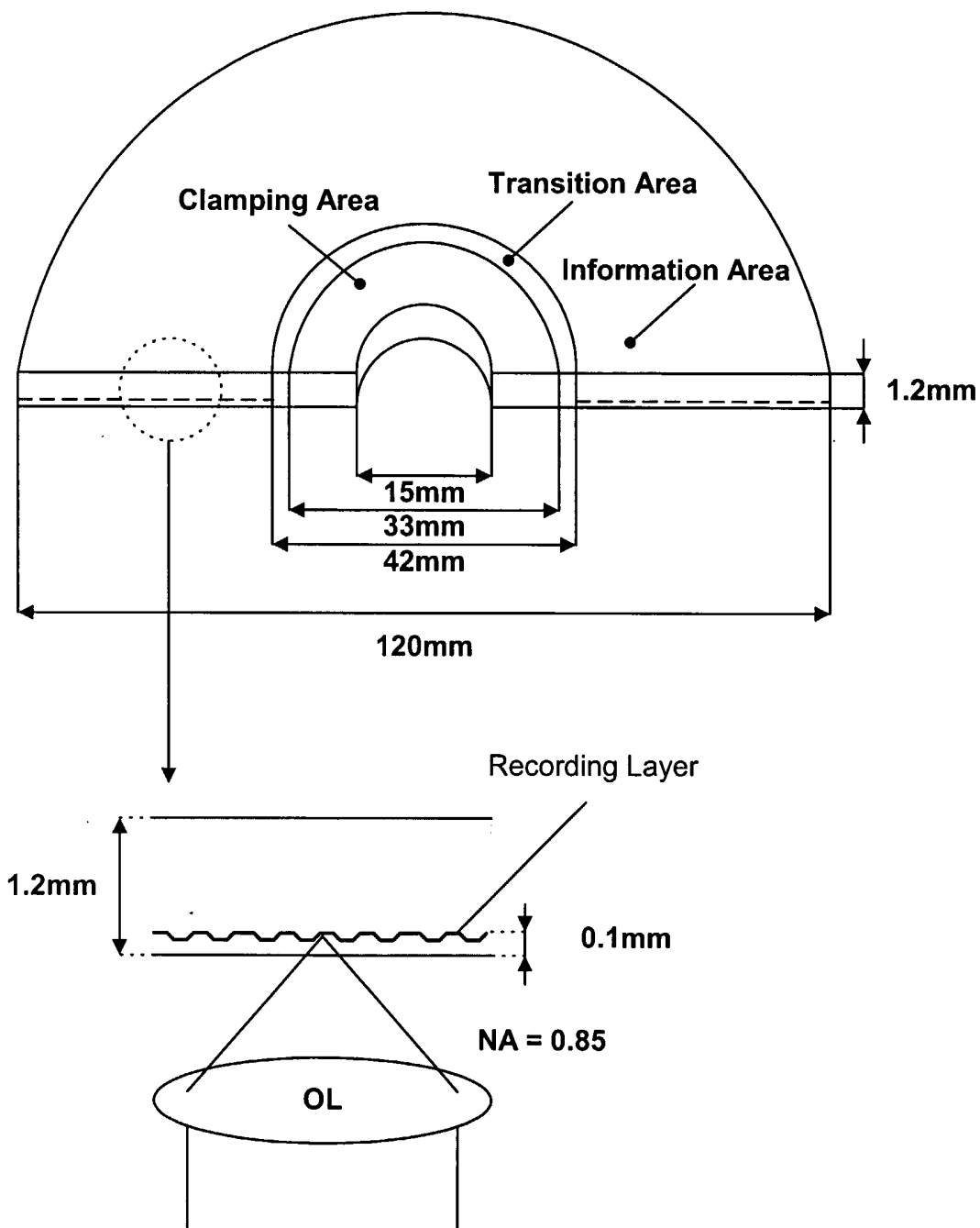

FIG. 4

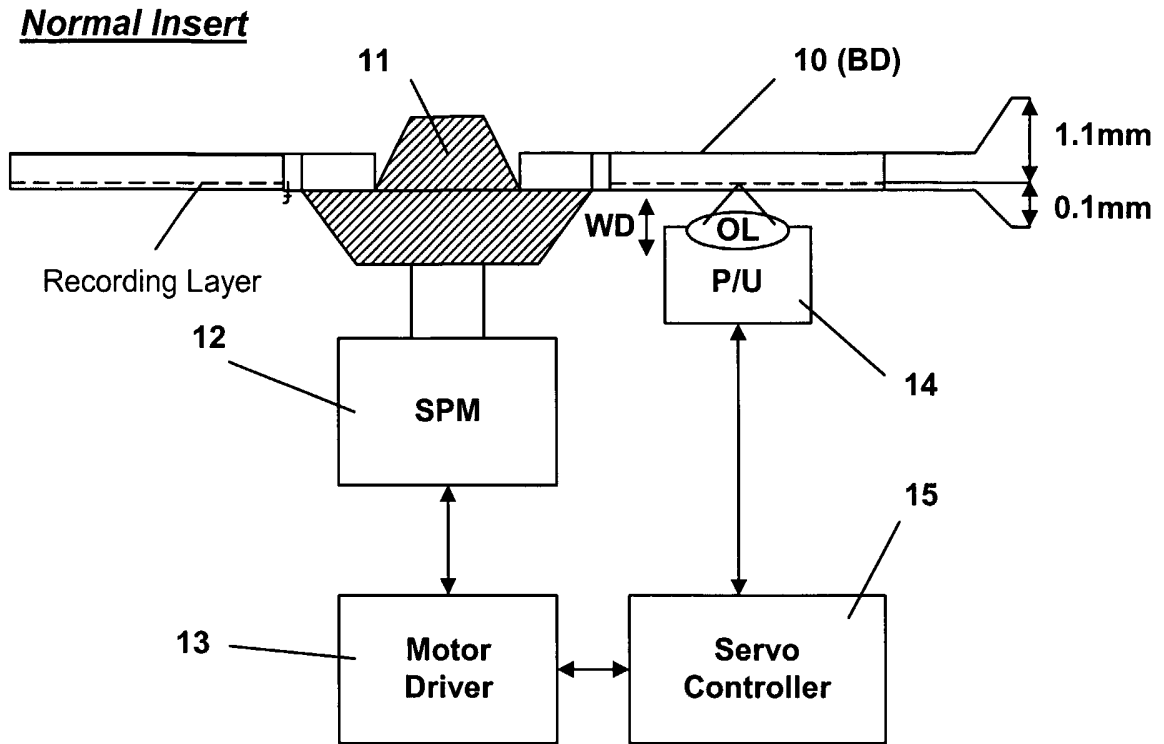

FIG. 5

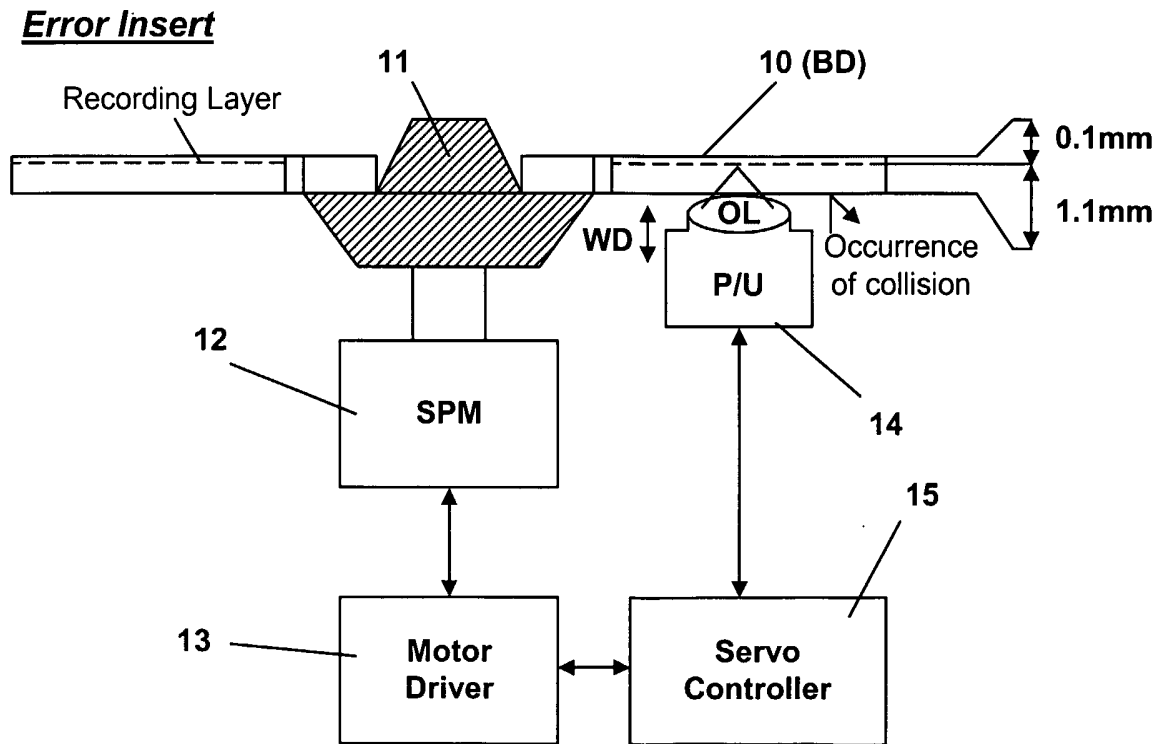

FIG. 6

BD (20)

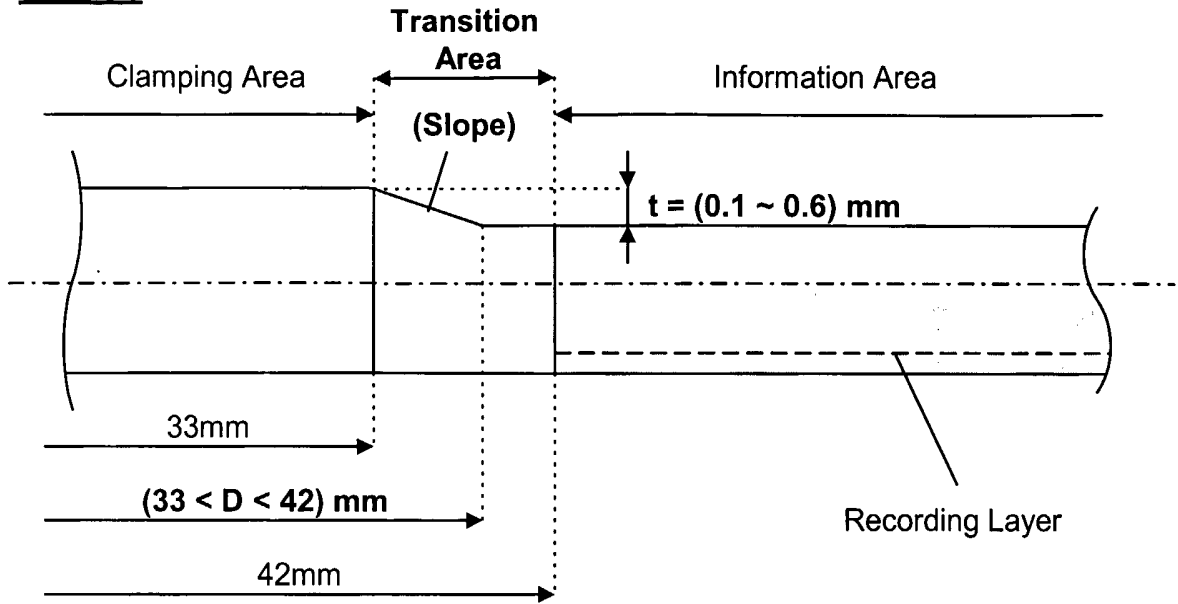
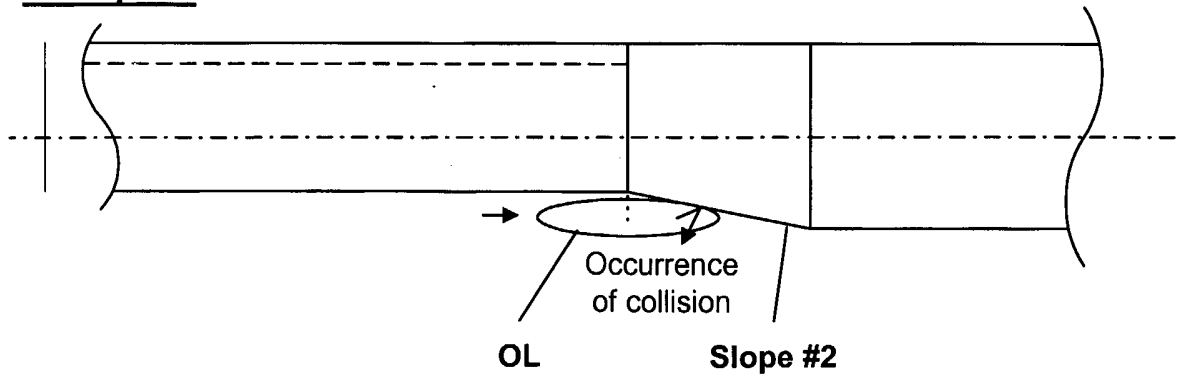

FIG. 7

Example 1



Example 2

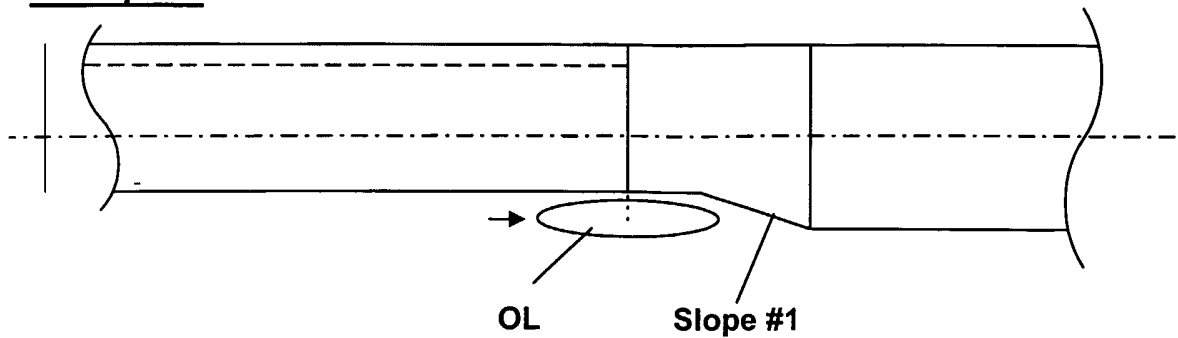

FIG. 8

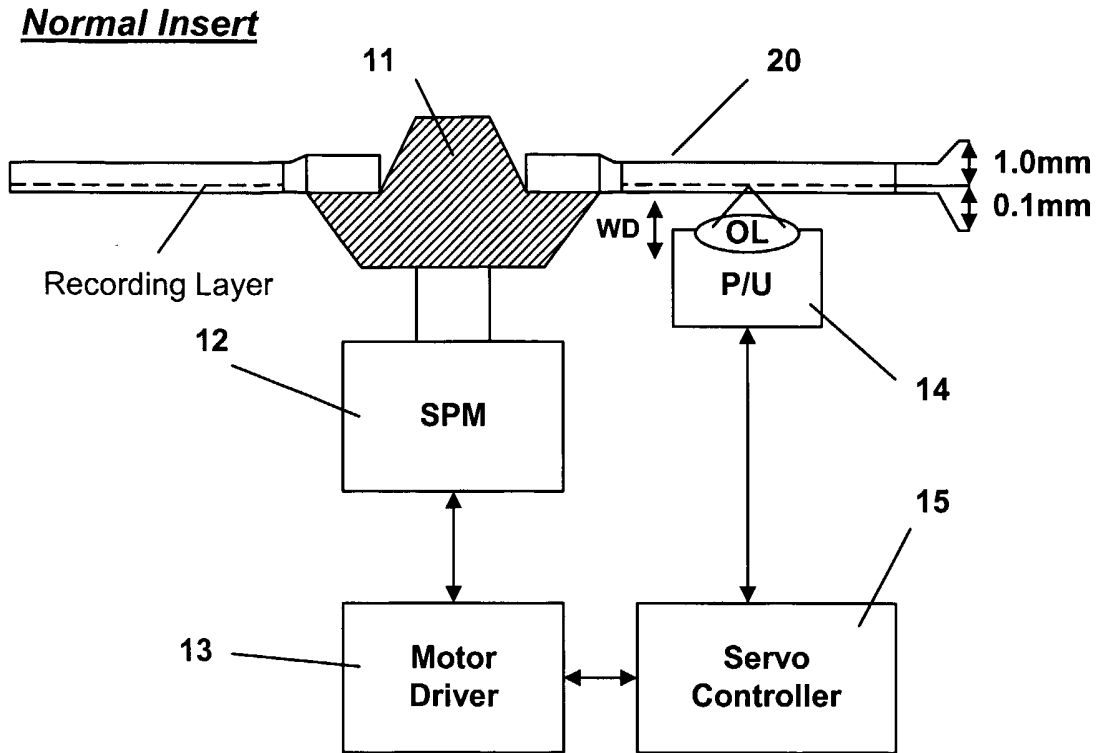

FIG. 9

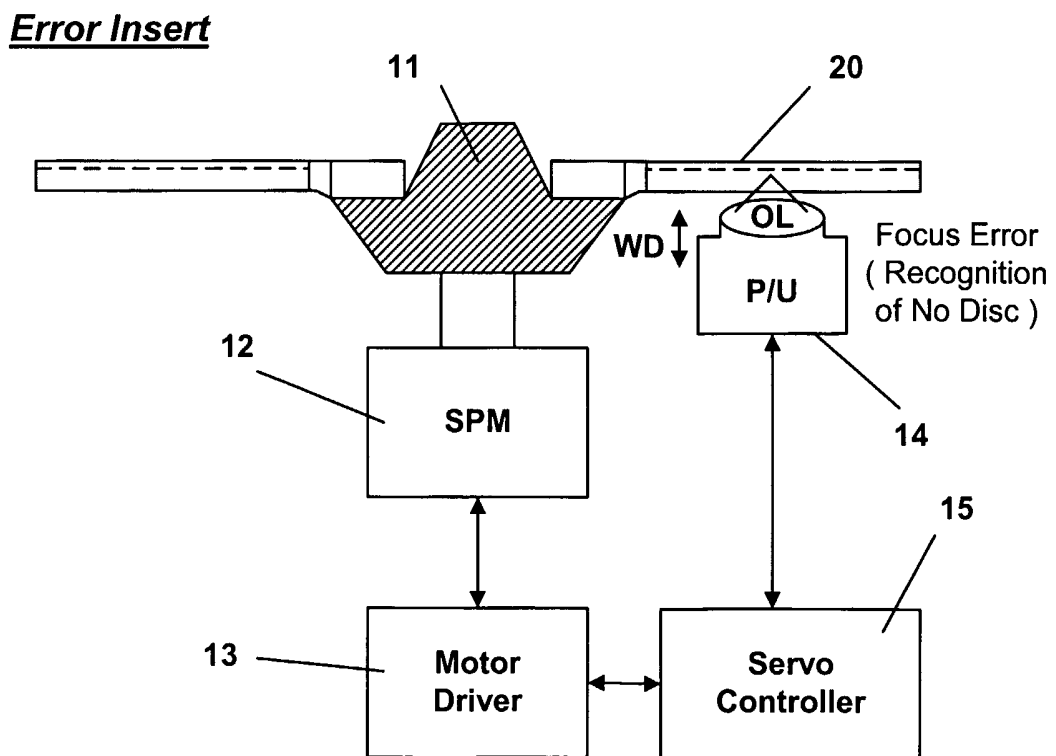

FIG. 10

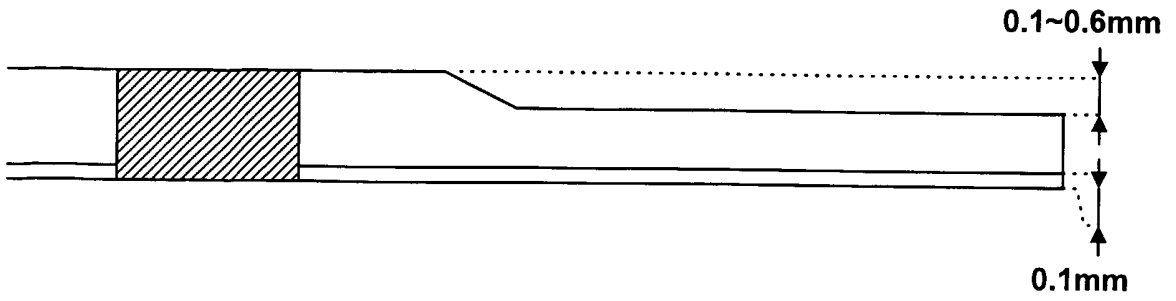

FIG. 11

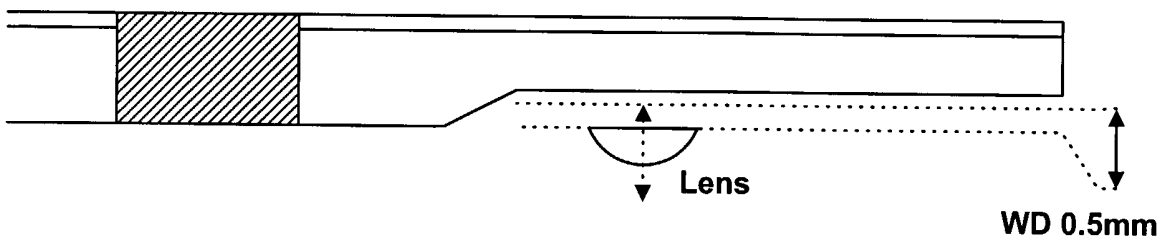

FIG. 12

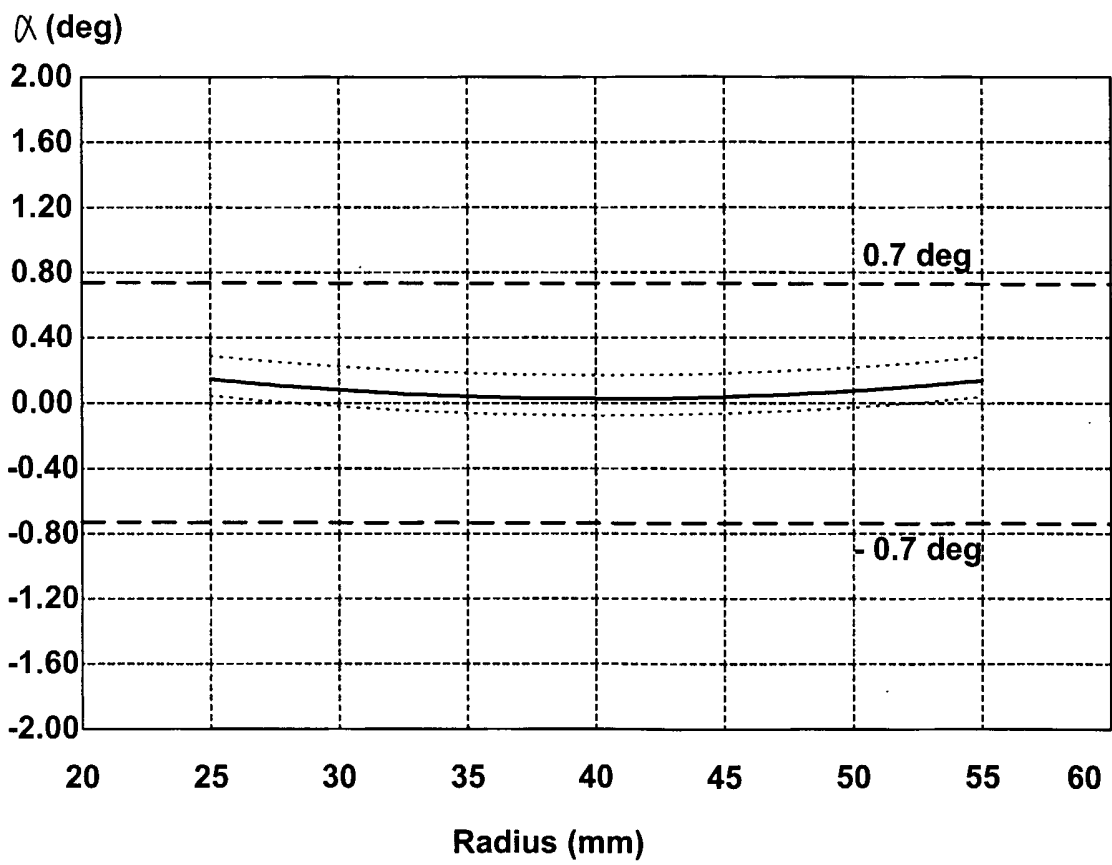
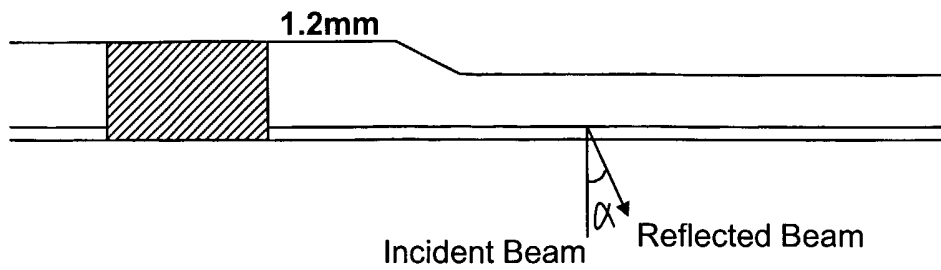
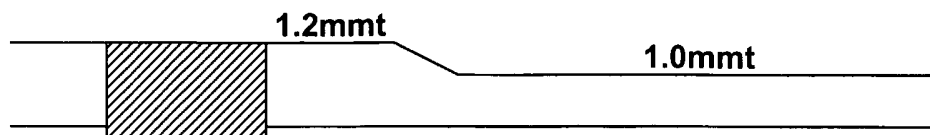
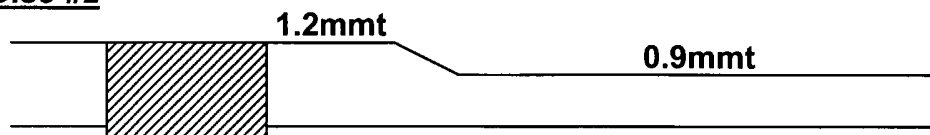

FIG. 13

Disc #1



Disc #2



α (deg)

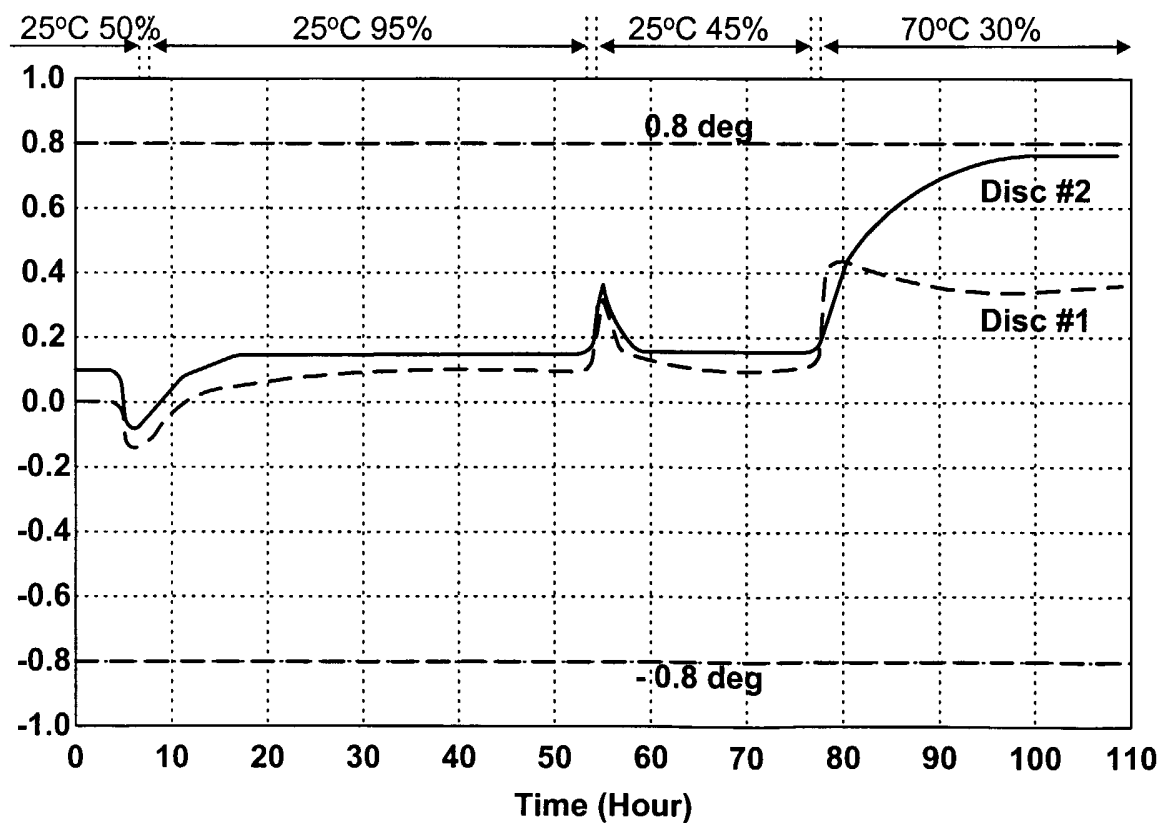

FIG. 14

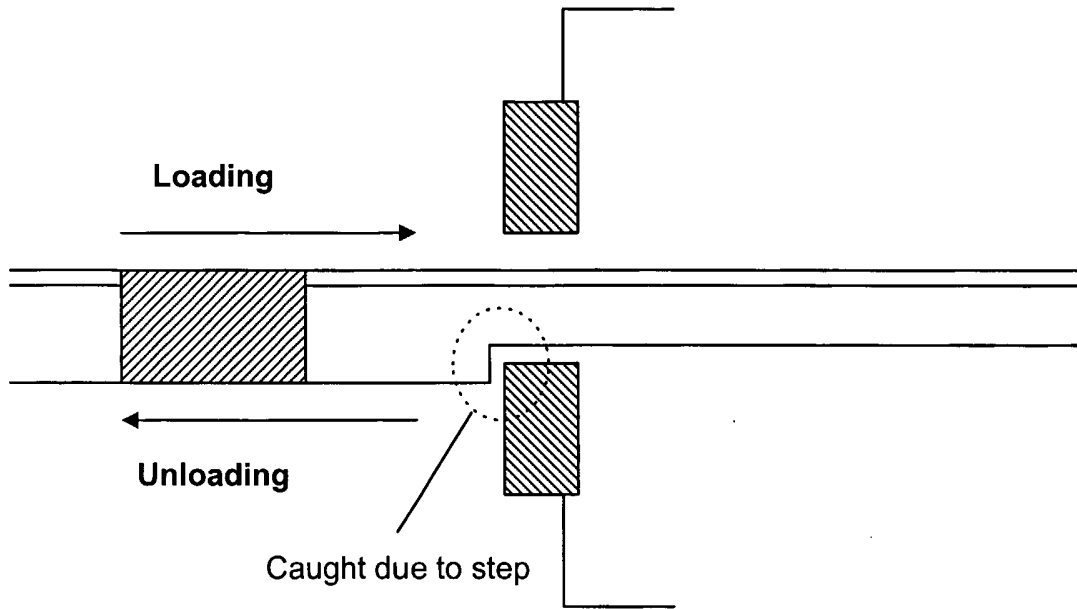
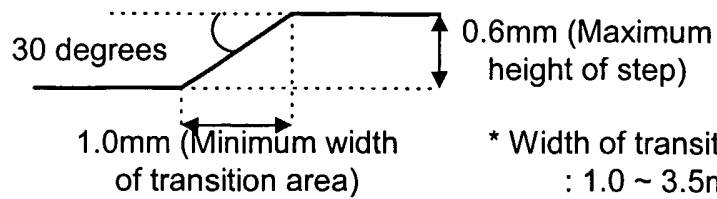
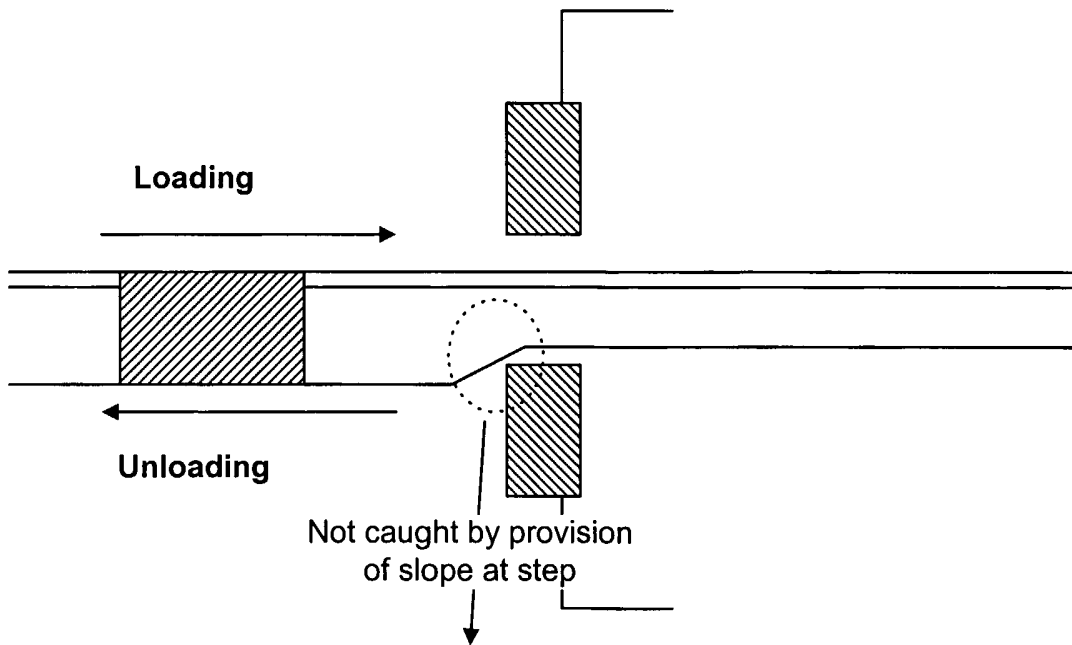

FIG. 15



* Width of transition area : 1.0 ~ 3.5mm

INTERNATIONAL SEARCH REPORT

International application No.
PCT/KR2004/001321**A. CLASSIFICATION OF SUBJECT MATTER****IPC7 G11B 7/24, G11B 7/0037**

According to International Patent Classification (IPC) or to both national classification and IPC

B. FIELDS SEARCHED

Minimum documentation searched (classification system followed by classification symbols)

G11B 7/24, G11B 7/002

Documentation searched other than minimum documentation to the extent that such documents are included in the fields searched

Electronic data base consulted during the international search (name of data base and, where practicable, search terms used)
WPI, PAJ "thickness, clamping, transition, information, step, slope, Blu-ray, OL(objective lens), pick-up, diameter"**C. DOCUMENTS CONSIDERED TO BE RELEVANT**

Category*	Citation of document, with indication, where appropriate, of the relevant passages	Relevant to claim No.
A	EP 1,258,872 A2 (LG ELECTRONICS INC.) 20 Nov. 2002 See the whole document	1-3, 6, 22-23, 31-32, 34, 40-41
A	JP 11-053764 A (SANYO ELECTRIC CO., LTD.) 26 Feb. 1999 See the whole document	1, 22, 31, 34, 40
A	EP 1,152,407 A2 (MATSUSHITA ELECTRIC IND CO., LTD.) 11 Jul. 2001 See the whole document	1, 22, 31, 34, 40
A	US 2002-0067689 A1 (KENJI YAMAZAKI) 06 Jun. 2002 See the whole document	1, 22, 31, 34, 40
A	US 6,507,559 B1 (Sharp Kabushiki Kaisha) 14 Jan. 2003 See the whole document	1, 22, 31, 34, 40

 Further documents are listed in the continuation of Box C. See patent family annex.

* Special categories of cited documents:

"A" document defining the general state of the art which is not considered to be of particular relevance

"E" earlier application or patent but published on or after the international filing date

"L" document which may throw doubts on priority claim(s) or which is cited to establish the publication date of citation or other special reason (as specified)

"O" document referring to an oral disclosure, use, exhibition or other means

"P" document published prior to the international filing date but later than the priority date claimed

"T" later document published after the international filing date or priority date and not in conflict with the application but cited to understand the principle or theory underlying the invention

"X" document of particular relevance; the claimed invention cannot be considered novel or cannot be considered to involve an inventive step when the document is taken alone

"Y" document of particular relevance; the claimed invention cannot be considered to involve an inventive step when the document is combined with one or more other such documents, such combination being obvious to a person skilled in the art

"&" document member of the same patent family

Date of the actual completion of the international search

17 SEPTEMBER 2004 (17.09.2004)

Date of mailing of the international search report

18 SEPTEMBER 2004 (18.09.2004)

Name and mailing address of the ISA/KR

Korean Intellectual Property Office
920 Dunsan-dong, Seo-gu, Daejeon 302-701,
Republic of Korea

Facsimile No. 82-42-472-7140

Authorized officer

KIM, Yong Woong

Telephone No. 82-42-481-5698

