

Nov. 11, 1947.

G. WEINSCHENK

2,430,626

POSTAL CARD

Filed Aug. 28, 1944

Fig. 1

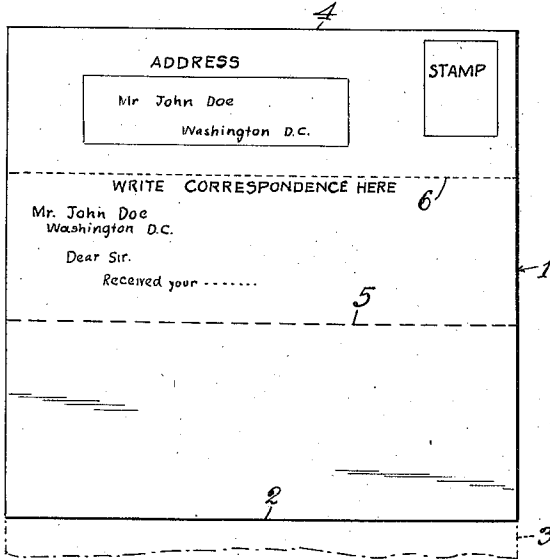

Fig. 3 Fig. 4

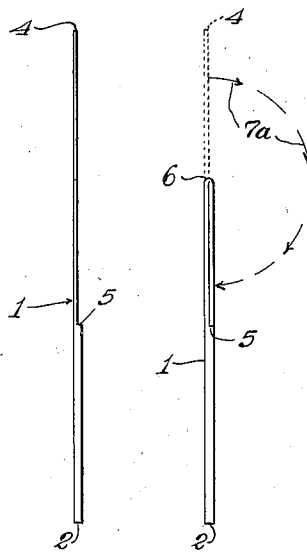

Fig. 2

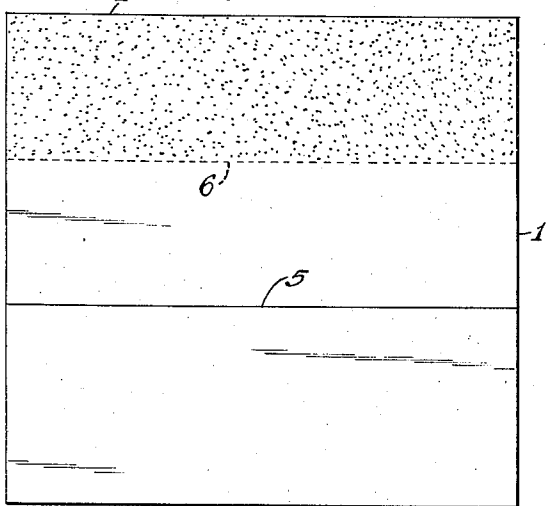

Fig. 7 Fig. 8

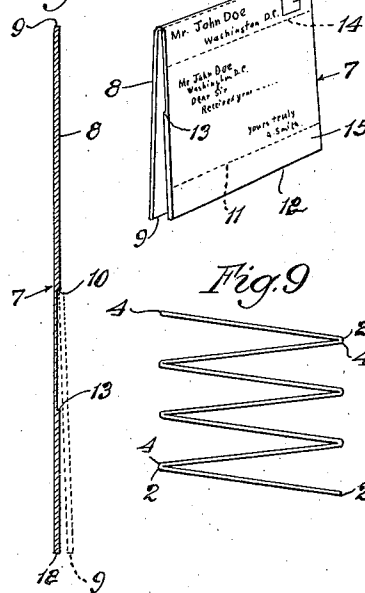

Fig. 9

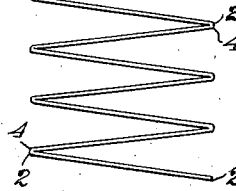

Fig. 5

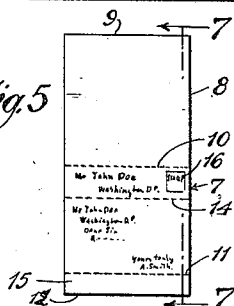
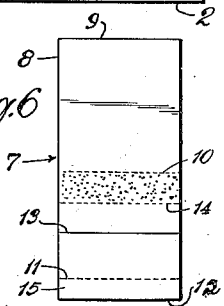

Fig. 6



Inventor
Gosbert Weinschenk
by
H. Sanders
Attorney.

UNITED STATES PATENT OFFICE

2,430,626

POSTAL CARD

Gosbert Weinschenk, Chicago, Ill.

Application August 28, 1944, Serial No. 551,539

2 Claims. (Cl. 229—92.8)

1

This invention relates to improvements in postal cards and more particularly to a postal card adapted for typewriter use. This invention may be considered a further development of my co-pending application for patent on Postal cards, Serial No. 444,077, filed May 22, 1942, now matured into Patent No. 2,365,789. One object is to provide a postal card that feeds into the typewriter as readily as ordinary paper stock. A further object is to provide a postal card that may be readily stocked in rolls or "books" and the complete roll or any part thereof fed continuously through the machine without the removal of any card or cards until the operation is completed, the address and message of each card being typed in the order stated, it being understood of course that one card at a time may be torn from the roll or book and used if desired.

A further object is to provide a postal card for typewriter use primarily wherein the complete address and message are presented to view together while the message is being typed. A still further object is to provide a postal card for typewriter use that is so supported in the typewriter that the message may utilize the complete full message-side of the card, the last line of the message being readily typed upon the lowermost edge of the card while the card is being held steady in position.

A further object is to provide a postal card for typewriter use having means for making a carbon copy of the address and message when desired. A still further object is to provide a postal card that lends itself most readily to speed in typing both address and the message, that requires practically no handling while in use, and that is inexpensive to make.

With the foregoing and other objects in view the invention consists in the combination and arrangement of parts to be hereinafter fully explained in the description, pointed out in the claims and illustrated in the drawing which forms a part of this patent and in which—

Fig. 1 is a face view of a single postal card embodying the invention, the address and a portion of the message being shown, before the card is folded for mailing, a portion of a flap or tab that is used when the card is fed alone into the typewriter being shown in dotted lines.

Fig. 2 is a view of the reverse face of the card with the flap or tab omitted.

Fig. 3 is an edge view of the card before it is folded.

Fig. 4 is a view similar to Fig. 3 showing the

2

card in full lines in folded position and partially in dotted lines in unfolded position.

Fig. 5 is a view on a reduced scale of a slightly modified form of card.

Fig. 6 is a view of the reverse side of the card.

Fig. 7 is a vertical sectional view through Fig. 5 on the line 7—7.

Fig. 8 is a view in elevational perspective of the card shown in Figs. 5, 6, 7, and

Fig. 9 is a view in edge elevation of a plurality of cards as they may be provided in "book" style ready for use, the free end of a terminal card being fed first into the typewriter.

Like reference characters denote corresponding parts throughout the several views.

In the use of postal cards on the typewriter considerable difficulty and a slow up in speed have been encountered in the past due to the thickness of the cards retarding the feeding operation.

This is entirely overcome in the instant invention by forming each card with a conventional or thick portion and a relatively thin portion integral therewith, the thin portion being fed first into the machine and then followed by the thick portion, the thin portion when the card is removed from the machine being folded centrally upon itself when it will be found to be of uniform thickness with the conventional thick portion.

Referring now to Figs. 1, 2, 3, 4 and 9 of the drawing the reference numeral 1 denotes a single card which when not intended for use in rolls, like theatre tickets, is provided at its lower body edge 2 with a flap 3. The card is formed of a body portion extending from the top edge 4 to the bottom or lower edge 2. That portion of the card from the top edge 4 to a transverse shoulder 5, substantially two-thirds the length of the body, is relatively thin while that portion of the body from the shoulder 5 to the lower body edge 2 is of conventional thickness which is preferably twice the thickness of the thin portion.

Extending transversely of the card at approximately the longitudinal center of the thin body portion is a line 6 and that portion of the card between said line 6 and the top edge 4 forms the address portion. That portion of the card between the line 6 and the lower edge 2 forms the message side or portion of the card. In use the cards 1 may be made single with a terminal flap 3. The card is inserted in the typewriter with the edge 4 first and the stamp or front face away from the operator so that this face will move into typing position. The address is now typed above the line 6 and the message below

3

same to the extreme lower body edge 2 if desired, the tab 3 serving to hold the body of the card in typing position in the machine while the last lines are typed. The card is now removed from the machine, the tab 3 torn away along the line 2 and the address portion of the card folded away from the message portion along the line 6 as denoted by the arrows 7a, Fig. 4. The card is now stamped and is ready for mailing. It will be noted that when the thin body portion of the card is folded along its longitudinal center line 6 the card is of uniform thickness from the edge 2 to the line 6 as shown in full lines in Fig. 4. When a number of cards are to be written rapidly they may be prepared in roll form with a flap 3 only on the last card of the roll.

The edge 4 of the first card is then inserted in the machine and the cards addressed and written as they appear consecutively in typing position. The rear face of the address portion of the card is gummed so that when folded against the reverse side of the message portion it will adhere thereto when first moistened. In Fig. 9 the cards are shown secured together in "book" form instead of in the roll form. The first card of the book is fed into the machine as described and thereafter the balance of the operation carried out.

Referring now to Figs. 5, 6, 7 and 8 a modified form is shown. The card 7 is formed with a second sheet portion 8 of uniform thickness extending from the free edge 9 to the perforated line 10 and with the original or directly typed portion, formed of portions of unequal thicknesses, that extends from said line 10 to the line 11 spaced from the lower free edge 12 of the card, said directly typed portion being relatively thin from the line 10 to a shoulder 13 and being bisected by the transverse line 14 to form the address portion between said line and the line 10 and the message portion between lines 14 and 11, that card portion between the lines 11 and 12 forming a tab 15, the reverse side of the address portion being gummed.

In use the card is folded along the line 10 and a sheet of carbon paper inserted between the folded portions. The card is now introduced into the machine with line 10 foremost and the outer face of the directly typed face that bears the stamp 16 away from the operator. As the address portion moves into typing position the address is typed and thereafter the message is typed upon the message portion below the line 14 and, if desired, all the way to the line 11, the card being held in the machine by the usual paper holders bearing against the flap 15.

The card is now removed from the machine and torn along the line 10 to separate the directly typed portion from the copy portion, the address portion is folded away from the message portion along the line 14 and adhered thereto at its junction with the shoulder 13. The flap 15 is now torn away and the card is stamped and

4

mailed. It will be observed that when the address portion is folded upon the line 14 it makes the card of uniform thickness from line 14 to line 12.

Obviously, numerous changes and modifications in the details of the embodiments of the invention will become apparent to those skilled in the art. It is intended that all such changes and modifications be comprehended within the scope of the invention which is to be limited only by the claims hereto appended.

What is claimed is:

1. A postal card for typewriter use having a body formed of thick and thin portions, said thin portion being gummed and of a length twice that of said thick portion, a shoulder defining the juncture of said thick and thin portions, the cards being adapted for multiple manufacture and stock in book form and for insertion, at one end of the book, into the typewriter for continuous consecutive use and thereafter to be separated from each other, the thin portion of each card then being folded about its longitudinal center line to dispose its free end in alignment with said shoulder to form a card of uniform thickness throughout.

2. A postal card book comprising a plurality of identical units detachably secured together, each unit having a message portion and an integral address portion, the message portion being of a length twice that of the address portion, one-half of said message portion being of the same thickness as said address portion, the several units adapted for insertion consecutively in a typewriter from end to end of the book to permit the units to be addressed and message-typed consecutively and continuously without interruption, said units thereafter being detached and individually folded along a line defining the juncture of said message and address portions to bring said address portion into facial alignment with the correspondingly thick one-half of said message portion, and means for securing said last named portions in said alignment.

GOSBERT WEINSCHENK.

REFERENCES CITED

The following references are of record in the file of this patent:

UNITED STATES PATENTS

Number	Name	Date
827,809	Mitchell	Aug. 7, 1906
884,701	Borden	Apr. 14, 1908
1,423,910	Campbell	July 25, 1922
2,018,984	Van Mackelenbergh	Oct. 29, 1935
2,270,455	Lichter	Jan. 20, 1942

FOREIGN PATENTS

Number	Country	Date
395,577	France	Jan. 4, 1909
247,377	Great Britain	Feb. 18, 1926