

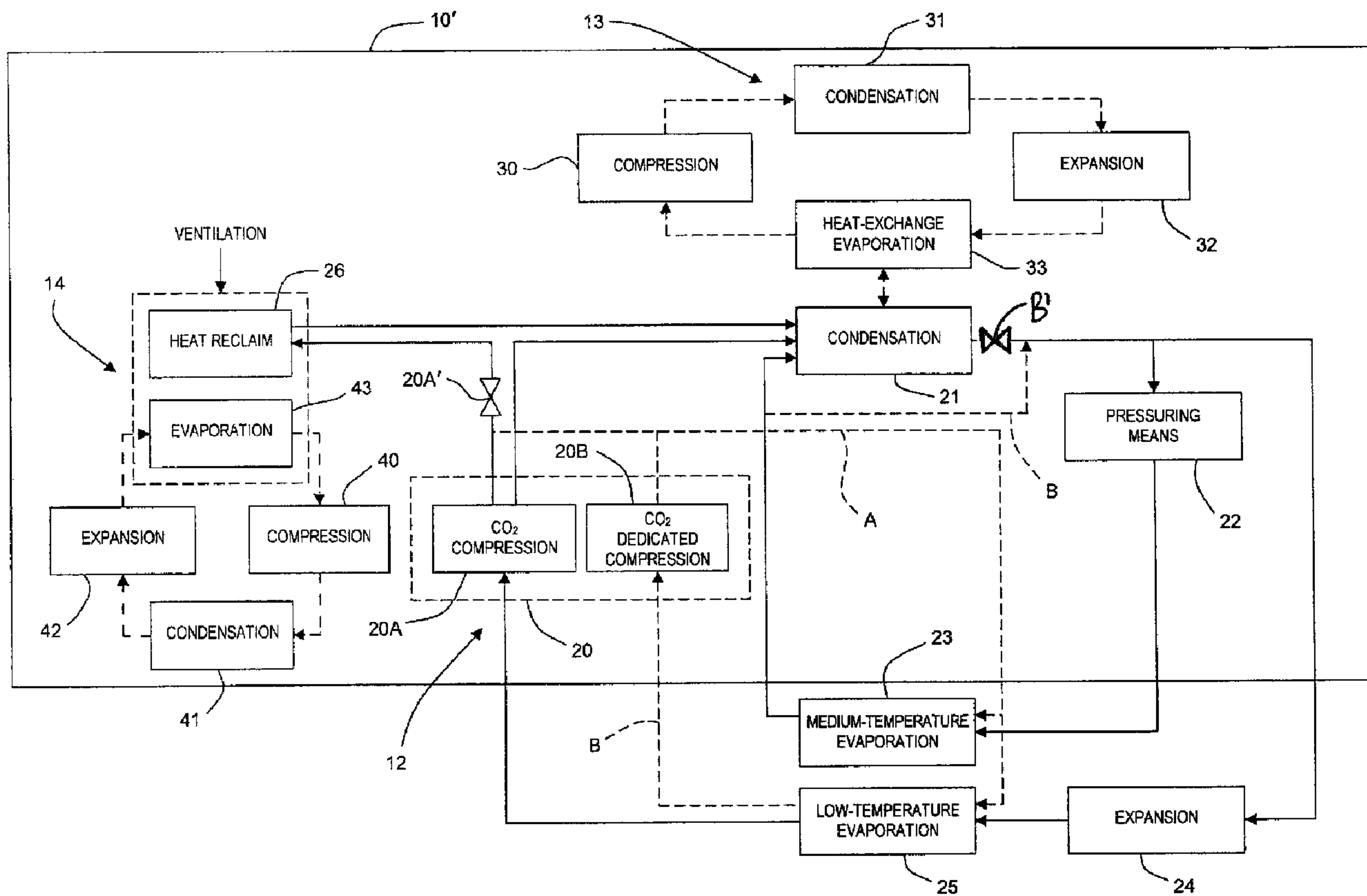

(22) Date de dépôt/Filing Date: 2009/04/17
(41) Mise à la disp. pub./Open to Public Insp.: 2009/10/18
(30) Priorité/Priority: 2008/04/18 (US61/046,004)

(51) Cl.Int./Int.Cl. *F25B 1/00* (2006.01)
(71) Demandeur/Applicant:
DUBE, SERGE, CA
(72) Inventeur/Inventor:
DUBE, SERGE, CA
(74) Agent: OGILVY RENAULT LLP/S.E.N.C.R.L.,S.R.L.

(54) Titre : UNITE DE REFRIGERATION AU DIOXYDE DE CARBONE
(54) Title: CO₂ REFRIGERATION UNIT



(57) **Abrégé/Abstract:**

A refrigeration unit comprises a CO₂ refrigeration circuit having a CO₂ compression stage in which CO₂ refrigerant is compressed, a CO₂ condensation stage having a tank in which CO₂ refrigerant is accumulated in a liquid state, at least one of pressuring means and an expansion stage to direct the CO₂ refrigerant from the CO₂ condensation stage to a CO₂ evaporation stage in which CO₂

(57) **Abrégé(suite)/Abstract(continued):**

refrigerant absorbs energy to refrigerate. A condensation circuit has a second refrigerant being circulated between a second compression stage, a second condensation stage, a second expansion stage and a second evaporation stage. A heat-exchanger unit by which the CO₂ refrigerant from the CO₂ refrigeration circuit is in heat exchange with the second refrigerant in the second evaporation stage such that the second refrigerant absorbs heat from the CO₂ refrigerant to at least partially liquefy the CO₂ refrigerant for the CO₂ condensation stage. A defrost circuit directing defrost CO₂ refrigerant from the CO₂ compression stage to the CO₂ evaporation stage to defrost at least one evaporator of the CO₂ evaporation stage, the defrost CO₂ refrigerant being subsequently returned to the CO₂ refrigeration circuit.

ABSTRACT

A refrigeration unit comprises a CO₂ refrigeration circuit having a CO₂ compression stage in which CO₂ refrigerant is compressed, a CO₂ condensation stage having a tank in which CO₂ refrigerant is accumulated in a liquid state, at least one of pressuring means and an expansion stage to direct the CO₂ refrigerant from the CO₂ condensation stage to a CO₂ evaporation stage in which CO₂ refrigerant absorbs energy to refrigerate. A condensation circuit has a second refrigerant being circulated between a second compression stage, a second condensation stage, a second expansion stage and a second evaporation stage. A heat-exchanger unit by which the CO₂ refrigerant from the CO₂ refrigeration circuit is in heat exchange with the second refrigerant in the second evaporation stage such that the second refrigerant absorbs heat from the CO₂ refrigerant to at least partially liquefy the CO₂ refrigerant for the CO₂ condensation stage. A defrost circuit directing defrost CO₂ refrigerant from the CO₂ compression stage to the CO₂ evaporation stage to defrost at least one evaporator of the CO₂ evaporation stage, the defrost CO₂ refrigerant being subsequently returned to the CO₂ refrigeration circuit.

CO₂ REFRIGERATION UNIT

CROSS REFERENCE TO RELATED APPLICATION

This patent application claims priority on United States Provisional Patent Application No. 61/046,004, filed
5 on April 18, 2008, by the present applicant.

FIELD OF THE APPLICATION

The present application relates to CO₂ refrigeration systems, for instance used in commercial applications such as supermarkets, industrial storage and
10 the like.

BACKGROUND OF THE ART

With the growing concern for global warming, the use of chlorofluorocarbons (CFCs) and hydrochlorofluorocarbons (HCFCs) as refrigerant has been identified as having
15 a negative impact on the environment. These chemicals have non-negligible ozone-depletion potential and/or global-warming potential.

As alternatives to CFCs and HCFCs, ammonia, hydrocarbons, and CO₂ are used as refrigerants. Although ammonia
20 and hydrocarbons have negligible ozone-depletion potential and global-warming potential as does CO₂, these refrigerants are highly flammable and therefore represent a risk to local safety. On the other hand, CO₂ is environmentally benign and locally safe.

25 SUMMARY OF THE APPLICATION

It is therefore an aim of the present application to provide a novel CO₂ refrigeration systems.

Therefore, in accordance with a first embodiment of the present application, there is provided a
30 refrigeration unit comprising: a CO₂ refrigeration circuit having a CO₂ compression stage in which CO₂ refrigerant is

compressed, a CO₂ condensation stage having a tank in which
CO₂ refrigerant is accumulated in a liquid state, at least
one of pressuring means and an expansion stage to direct the
CO₂ refrigerant from the CO₂ condensation stage to a CO₂
5 evaporation stage in which CO₂ refrigerant absorbs energy to
refrigerate; a condensation circuit having a second
refrigerant being circulated between a second compression
stage, a second condensation stage, a second expansion stage
and a second evaporation stage; a heat-exchanger unit by
10 which the CO₂ refrigerant from the CO₂ refrigeration circuit
is in heat exchange with the second refrigerant in the
second evaporation stage such that the second refrigerant
absorbs heat from the CO₂ refrigerant to at least partially
liquefy the CO₂ refrigerant for the CO₂ condensation stage;
15 and a defrost circuit directing defrost CO₂ refrigerant from
the CO₂ compression stage to the CO₂ evaporation stage to
defrost at least one evaporator of the CO₂ evaporation
stage, the defrost CO₂ refrigerant being subsequently
returned to the CO₂ refrigeration circuit.

20 Further in accordance with the first embodiment, a
discharge of the CO₂ compression stage is fed to the heat-
exchanger unit for releasing heat to then reach the tank of
the CO₂ condensation stage.

Still further in accordance with the first
25 embodiment, the CO₂ evaporation stage has at least medium-
temperature evaporators and low-temperature evaporators,
with a line directing CO₂ refrigerant exiting the low-
temperature evaporators to the CO₂ compression stage, and
with the pressuring means upstream of the medium-temperature
30 evaporators to feed CO₂ refrigerant to the medium-
temperature evaporators, with another line directing CO₂
refrigerant exiting the medium-temperature evaporators to
the CO₂ condensation stage.

Still further in accordance with the first
35 embodiment, the CO₂ evaporation stage has at least medium-
temperature evaporators and low-temperature evaporators,
with a line directing CO₂ refrigerant exiting the low-

temperature evaporators to the CO₂ compression stage, and with the expansion stage upstream of the medium-temperature evaporators to feed CO₂ refrigerant to the medium-temperature evaporators, with another line directing CO₂ refrigerant exiting the medium-temperature evaporators to the CO₂ compression stage.

Still further in accordance with the first embodiment, a defrost reservoir between the CO₂ evaporation stage and the CO₂ compression stage collects the defrost CO₂ refrigerant exiting the defrost circuit, a suction of the CO₂ compression stage connected to the defrost reservoir to collect CO₂ refrigerant in a gas state for the CO₂ refrigeration circuit.

Still further in accordance with the first embodiment, a discharge line extends from the CO₂ compression stage to the defrost reservoir to selectively flush CO₂ refrigerant from the defrost reservoir through another line extending from the defrost reservoir to the tank in the CO₂ condensation stage.

Still further in accordance with the first embodiment, at least one dedicated compressor is provided in the CO₂ compression stage to collect at least part of the defrost CO₂ refrigerant exiting the defrost circuit, to compress and discharge the defrost CO₂ refrigerant to the CO₂ refrigeration circuit.

Still further in accordance with the first embodiment, a pressure-reducing valve on a discharge line of the CO₂ compression stage, downstream of a defrost line feeding defrost CO₂ refrigerant to the defrost circuit, maintains a pressure of the CO₂ refrigerant in the CO₂ refrigeration circuit downstream of the pressure-reducing valve lower than the pressure of the defrost CO₂ refrigerant.

Still further in accordance with the first embodiment, the defrost CO₂ refrigerant is circulated in the CO₂ evaporation stage of the defrost circuit at a pressure below 700 Psi.

Still further in accordance with the first embodiment, the defrost CO₂ refrigerant is circulated in the CO₂ evaporation stage of the defrost circuit at a pressure between 300 and 425 Psi.

5 Still further in accordance with the first embodiment to claim 1, a heat reclaim stage in a discharge line of the CO₂ compression stage reclaims heat from the CO₂ refrigerant.

10 Still further in accordance with the first embodiment, the heat reclaim stage comprises a coil in a ventilation duct to heat ventilation air.

15 Still further in accordance with the first embodiment, the condensation circuit has a pressure-maintaining line extending from a discharge of the second compression stage to a suction of the second compression stage, the pressure-maintaining line being selectively opened to maintain a minimum operating pressure at a suction of the second compression stage.

20 Still further in accordance with the first embodiment, the condensation circuit has a second heat-exchanger by which the second refrigerant exiting the second compression stage selectively heats the second refrigerant exiting the second condensation stage to subsequently feed the second refrigerant exiting the second condensation stage
25 directly to the second compression stage.

Still further in accordance with the first embodiment, a line extends from the CO₂ evaporation stage to the CO₂ condensation stage to direct defrost CO₂ refrigerant from the defrost circuit to the refrigeration circuit.

30 In accordance with a second embodiment of the present application, there is provided a refrigeration unit comprising: a casing; a CO₂ refrigeration circuit having a CO₂ compression stage in which CO₂ refrigerant is compressed, a CO₂ condensation stage having a tank in which
35 CO₂ refrigerant is accumulated in a liquid state, at least one of pressuring means and an expansion stage to direct the CO₂ refrigerant from the CO₂ condensation stage to a CO₂

evaporation stage in which CO₂ refrigerant absorbs energy to refrigerate, with at least the CO₂ compression stage, and the CO₂ condensation stage being in the casing; a condensation circuit having a second refrigerant being
5 circulated between a second compression stage, a second condensation stage, a second expansion stage and a second evaporation stage, at least the second compression stage, the second expansion stage and the second evaporation stage being in the casing; and a heat-exchanger unit in the casing
10 by which the CO₂ refrigerant from the CO₂ refrigeration circuit is in heat exchange with the second refrigerant in the second evaporation stage such that the second refrigerant absorbs heat from the CO₂ refrigerant to at least partially liquefy the CO₂ refrigerant for the CO₂
15 condensation stage.

Further in accordance with the second embodiment, a defrost circuit directs defrost CO₂ refrigerant from the CO₂ compression stage to the CO₂ evaporation stage to defrost at least one evaporator, the defrost CO₂ refrigerant
20 being subsequently returned to the CO₂ refrigeration circuit.

Still further in accordance with the second embodiment, the at least one of pressuring means and expansion stage are in the casing.

25 Still further in accordance with the second embodiment, a ventilation circuit is provided in which circulates a third refrigerant between a third compression stage, a third condensation/gas cooling stage, a third expansion stage and a third evaporation stage, at least the
30 third compression stage, the third condensation/gas cooling stage, and the third expansion stage being in the casing, with the third evaporation stage adapted to be in a ventilation duct to absorb heat from ventilation air.

Still further in accordance with the second
35 embodiment, a heat reclaim stage is provided in a discharge line of the CO₂ compression stage to reclaim heat from the CO₂ refrigerant, the heat reclaim stage comprising a coil

adapted to be in said ventilation duct to heat ventilation air.

Still further in accordance with the second embodiment, at least an other one of the refrigeration unit
5 in another one of the casing, the other one of the refrigeration unit being without one of the condensation circuit, and being in heat-exchange relation with the heat-exchange unit of the first one of the refrigeration unit.

In accordance with a third embodiment of the
10 present application, there is provided a refrigeration unit of the type having a CO₂ refrigeration circuit with a CO₂ compression stage in which CO₂ refrigerant is compressed, a CO₂ condensation stage having a tank in which CO₂ refrigerant is accumulated in a liquid state, an expansion
15 stage to direct the CO₂ refrigerant from the CO₂ condensation stage to a CO₂ evaporation stage in which CO₂ refrigerant absorbs energy to refrigerate, the CO₂ evaporation stage having at least two evaporators, the refrigeration unit comprising at least one line connected
20 from the CO₂ condensation stage to one expansion valve of the expansion stage, the line diverging into at least two lines each connected to a balancing valve and an own one of the evaporators, such that CO₂ refrigerant expanded by the one expansion valve is directed to the at least two
25 evaporators through the balancing valves.

Further in accordance with the third embodiment, the expansion stage is in a casing with the CO₂ compression stage and the CO₂ condensation stage at a distal location from the CO₂ evaporation stage.

30 Still further in accordance with the third embodiment, the refrigeration unit is retrofitted to existing evaporators.

Still further in accordance with the third embodiment, a defrost circuit directs defrost CO₂
35 refrigerant from the CO₂ compression stage to the CO₂ evaporation stage to defrost the evaporators, the defrost

CO₂ refrigerant being subsequently returned to the CO₂ refrigeration circuit.

BRIEF DESCRIPTION OF THE DRAWINGS

Fig. 1 is a block diagram of a CO₂ refrigeration unit in accordance with a first embodiment of the present application;

Fig. 2 is a block diagram of a CO₂ refrigeration unit in accordance with a second embodiment of the present application, featuring refrigerant defrost;

Fig. 3 is a block diagram of CO₂ refrigeration units sharing a high-pressure condensing circuit, in accordance with a third embodiment of the present application;

Fig. 4 is a schematic view of a CO₂ condensation tank, as used in the CO₂ refrigeration units of Figs. 1-3;

Fig. 5 is a schematic plan of the CO₂ refrigeration unit of Figs. 1 and 2;

Fig. 6 is a block diagram of the high-pressure condensing circuit of the CO₂ refrigeration unit of Fig. 1, in accordance with another embodiment of the present application;

Fig. 7 is a block diagram of the CO₂ refrigeration unit of Fig. 1, with high-temperature evaporation;

Fig. 8 is a block diagram of a CO₂ refrigeration unit in accordance with a fourth embodiment of the present application, featuring medium-temperature compression;

Fig. 9 is a block diagram of a CO₂ refrigeration unit in accordance with a fifth embodiment of the present application, featuring a defrost-reservoir;

Fig. 10 is a block diagram of the high-pressure condensing circuit of Fig. 6, with a pressure-maintaining line; and

Fig. 11 is a block diagram of an expansion arrangement of a CO₂ refrigeration unit.

DESCRIPTION OF THE PREFERRED EMBODIMENTS

Referring now to the drawings, and more particularly to Fig. 1, a CO₂ refrigeration unit in accordance with a first embodiment of the present application is generally at 10. The CO₂ refrigeration unit 10 of Fig. 1 is defined by a casing that encloses parts of a CO₂ refrigeration circuit 12, a high-pressure condensing circuit 13 cascaded with the CO₂ refrigeration circuit 12, and a ventilation circuit 14. The CO₂ refrigeration unit 10 is primarily used as a rooftop unit providing refrigeration for the needs of a building, but may also be used within a building, for instance in a mechanical room. The CO₂ refrigeration unit described hereinafter are well suited for being retro-fitted to existing installations, using the existing evaporators and/or condensers on site. Some of the embodiments described hereinafter pertain to a casing enclosing most components, which casing is readily installed as a whole with all components ready for operation.

The CO₂ refrigeration unit 10 provides cooling energy for medium-temperature and low-temperature refrigerated cabinets and enclosures in the form of liquid or gaseous CO₂ as fed by the CO₂ refrigeration circuit 12. Moreover, the CO₂ refrigeration unit 10 provides air-conditioning and heating energy for a ventilation system, as fed by the ventilation circuit 14.

The CO₂ refrigeration circuit 12 is a closed circuit in which liquid/gaseous CO₂ circulates. The CO₂ refrigeration circuit 12 has a compression stage, in which gaseous CO₂ is compressed by one or more compressors. The compressed CO₂ then reaches a condensation stage 21, in which the compressed CO₂ releases energy. The condensation stage 21 features a condensation tank in heat exchange with the high-pressure condensing circuit 13, as will be described hereinafter. The cascaded relation with the high-pressure condensing circuit 13 is due to the limitations in ambient temperature condensation for the CO₂. The high-

pressure condensing circuit 13 provides refrigerant at a temperature allowing condensation of the CO₂.

Liquid CO₂ then exits the condensation stage 21 and the CO₂ refrigeration circuit 12 to reach the refrigerated units (e.g., refrigerated cabinets or enclosures) within the building.

In the embodiment of Fig. 1, the liquid CO₂ is directed either to medium-temperature refrigerated units (e.g., for non-frozen goods, such as produce, meats, dairy) or low-temperature refrigerated units (e.g., for frozen goods).

In the medium-temperature branch, liquid CO₂ is fed to the evaporation stage 23 by pressuring means 22 (in or out of the casing of the refrigeration unit 10). The pressuring means 22 are a pump or like mechanical device suitable to direct the flow of liquid CO₂ to the evaporation stage 23. The evaporation stage 23 comprises one or more evaporators located in refrigerated enclosures or cabinets. The evaporators are in a heat-exchange relation with a fluid, such as air, blown thereon. The evaporators absorb heat from the air, to provide the refrigerated units with cold energy. The liquid CO₂ exiting the medium-temperature evaporation stage 23 is then directed to the condensation stage 21.

In the low-temperature branch, liquid CO₂ is fed to the expansion stage 24. The expansion stage 24 features expansion valves to vaporize the liquid CO₂, so as to subsequently feed gaseous CO₂ to the low-temperature evaporation stage 25. The evaporation stage 25 comprises one or more evaporators located in refrigerated enclosures or cabinets, typically enclosing frozen goods. The evaporators are in a heat-exchange relation with a fluid, such as air, blown thereon. The evaporators absorb heat from the air, to provide the refrigerated units with cold energy. The gaseous CO₂ exiting the low-temperature evaporation stage 25 is then directed to the compression stage 20.

It is pointed out that the higher volumetric capacity/high working pressures of CO₂ enable the use of small-dimension lines toward the evaporation stages 23 and 25, and back to the compression stage 20.

5 It is commonly known to reclaim heat from refrigerant downstream of the compression stage 20, as the heat is otherwise lost in the condensation stage. In the embodiment of Fig. 1, the CO₂ refrigeration circuit 12 has a heat reclaim coil 26, in heat exchange relation with the
10 ventilation circuit 14. The heat reclaim stage 26 is a dehumidifier coil that is for instance positioned in a ventilation duct to dehumidify air-conditioning air. The dehumidifier coil may alternatively or concurrently be a heating coil in a ventilation duct to heat the ventilation
15 air. It is pointed out that the CO₂ directed to the heat reclaim stage 26 is in a transcritical state. The heat reclaim 26 can be used for other purposes, for instance to heat water. It is considered to interrelate all heat reclaim coils 26 (e.g., for various units 10, 10' or the
20 like) with one circuit in which another refrigerant circulates, to accumulate heat from the heat reclaim coils 26.

Still referring to Fig. 1, a valve is provided on the line connecting the heat reclaim stage 26 to the
25 condensation stage 21. The valve is a modulating or floating valve, or any other suitable type of valve, that controls the condensation pressure in the heat reclaim stage 26. The condensation pressure is increased or lowered as a function of the exterior/interior temperature, as an
30 example. Other configurations are considered to control the pressure in the heat reclaim stage 26.

In Fig. 7, a CO₂ refrigeration unit similar to the CO₂ refrigeration unit 10 of Fig. 1 is illustrated with high-temperature evaporation, for instance for refrigerated
35 cabinets for fruits and vegetables. The circuit features an expansion stage 28 and the evaporators 29, and a dedicated compressor at the suction of the evaporators 29. An inlet

regulating valve 20B' is optionally provided in the discharge line of the dedicated compressor 20B to maintain suitable operating pressures for the dedicated compressor 20B. Alternative features and configurations (e.g., defrost) are available for the CO₂ refrigeration unit for Fig. 7, but are not illustrated for simplicity purposes. Still referring to Fig. 1, the high-pressure condensing circuit 13 is a closed circuit cascaded with the CO₂ refrigeration circuit 12. A chemical refrigerant (i.e., synthetic refrigerant, glycol or the like) circulates in the high-pressure condensing circuit 13. In the embodiment of Fig. 1, the high-pressure condensing circuit 13 is at least partially enclosed in the casing of the CO₂ refrigeration unit 10.

The condensing circuit 13 has a compression stage 30, in which at least one compressor produces high-pressure gas refrigerant. The compressors of the compression stage 30 are conventional compressors, variable-speed ammonia compressors or oil-free magnetic-bearing compressors, such as Danfoss-Turbocor compressors. The gas refrigerant is directed from the compression stage 30 to the condensation stage 31, in which the refrigerant releases heat. It is contemplated to provide the condensation stage 31 with a condenser coil and fans that will expel heat to the environment. The condenser coil and fans may be existing units from a retrofitted system.

The refrigerant is then directed to an expansion stage 32, wherein the refrigerant is vaporized to subsequently reach the heat-exchange evaporation stage 33. In the heat-exchange evaporation stage 33, the refrigerant absorbs heat from the gaseous CO₂ in the condensation stage 21 of the CO₂ refrigeration circuit 12. The refrigerant is then directed to the compression stage 30 to complete the refrigeration cycle.

In the embodiment of Fig. 1, the high-pressure condensing circuit 13 is fully enclosed in the casing of the CO₂ refrigeration unit 10. Accordingly, the volume of

refrigerant required to operate the condensing circuit 13 is reduced when compared to a similar rooftop refrigeration unit having lines extending to the refrigerated cabinets and enclosures within a building. Instead, CO₂ is used as high-
5 volume refrigerant, and CO₂ is considered less harmful to the environment.

Referring to Fig. 1, the ventilation circuit 14 is a closed circuit in which circulates a chemical refrigerant. In the embodiment of Fig. 1, the ventilation circuit 14 is
10 fully enclosed in the casing of the CO₂ refrigeration unit 10, with a ventilation duct circulating air in the CO₂ refrigeration unit 10. Alternatively, some parts of the ventilation circuit 14 may extend into the building, such as evaporation coils, the compression stage 40 and the
15 condensation stage 41.

The ventilation circuit 14 has a compression stage 40, in which at least one compressor compresses the refrigerant to a gas state. The gas refrigerant is directed from the compression stage 40 to the condensation stage 41,
20 in which the refrigerant releases heat. It is contemplated to provide the condensation stage 41 with a condenser coil and fans that will expel heat to the environment. It is pointed out that the condensation stage 41 may simply be a gas-cooling stage as the refrigerant does not necessarily
25 change phase, for instance if CO₂ refrigerant is used. To simplify the illustrations, stage 41 is referred to as condensation stage.

The refrigerant is then directed to an expansion stage 42, wherein the refrigerant is vaporized to
30 subsequently reach the evaporation stage 43. In the evaporation stage 43, the refrigerant absorbs heat ventilation air, so as to produce air-conditioned air. The refrigerant is then directed to the compression stage 40 to complete the refrigeration cycle.

35 The ventilation circuit 14 is optional in the CO₂ refrigeration unit 10, as some buildings may not need air-conditioning, or might already have independent air-

conditioning units. The ventilation circuit 14 may be in its own casing, and shared amongst a plurality of ventilation ducts.

Referring to Fig. 2, a CO₂ refrigeration unit is illustrated at 10'. The CO₂ refrigeration unit 10' is similar to the CO₂ refrigeration unit 10 of Fig. 1, but features refrigerant defrost by way of a defrost circuit. Accordingly, like elements between the CO₂ refrigeration units 10 and 10' will bear like reference numerals.

The defrost circuit of the CO₂ refrigeration unit 10' has refrigerant lines A extending from the compression stage 20 to the evaporation stages 23 and 25, to feed hot gaseous CO₂ refrigerant to the evaporation stages 23 and/or 25. Although not illustrated, suitable valves, pressure controls and/or regulators are provided in the lines A and in the evaporation stages 23 and 25 to temporarily stop the flow of cooling refrigerant to the evaporators, so as to proceed with the defrost of evaporators from the stages 23 and 25. For instance, the defrost refrigerant may be fed to the low-temperature evaporation stage 25 upstream of the expansion stage 24, so as not to have a defrost line extending from the compression stage 20 to the refrigerated cabinet. Suitable valves are thus required to feed defrost refrigerant to the low-temperature evaporation stage 25, including for instance a by-pass solenoid valve and line to by-pass the expansion stage 24. It is preferred that any CO₂ refrigerant in a liquid state from the refrigeration circuit be flushed out of the evaporators 23 and/or 25 prior to a defrost cycle. This is performed by exposing the evaporators 23 and/or 25 (where applicable) to the suction of the compression stage 20 while cutting the feed of CO₂ refrigerant from the condensation stage 21. The flush allows the defrosting of the evaporators 23 and/or 25 more efficiently, and in less time.

At the outlet of a defrost evaporator from the stages 23 and 25, the defrost CO₂ is directed to any other stage of the CO₂ refrigeration circuit 12 that can receive

the CO₂ in the state it is in. In the embodiment of Fig. 2, the defrost CO₂ is directed to the compression stage 20. It is considered to provide a dedicated compressor 20B that will be dedicated to receiving defrost CO₂, and feeding defrost CO₂ to the defrost circuit, as illustrated by line A. Line B is provided at the evaporation stages 23 and 25 to direct defrost CO₂ to the dedicated compressor 20B, or to mix with condensed CO₂ in the tank 50 of the condensation stage 20, or downstream of the condensation stage 20, with a valve B' facilitating this latter option. The other compressors 20A receive the CO₂ circulating in the refrigeration cycle, from the low-temperature evaporation stage 25. Other configurations are also considered.

An inlet regulating valve 20A' is optionally provided in the discharge of the compressors 20A so as to ensure that the pressure in the discharge line is suitable for the compressors 20A. The valve 20A' may also be used to direct some refrigerant of the compressors 20A to the defrost line A, as illustrated in Fig. 2.

It is also observed that the pressuring means 22 are within the casing of the CO₂ refrigeration unit 10', and are therefore part of the roof-top unit. However, the pressuring means 22 may also be positioned adjacent to the medium-temperature evaporators 23 within the building, as is illustrated in Fig. 1.

Referring to Fig. 3, a plurality of CO₂ refrigeration units are illustrated at 10". The CO₂ refrigeration units 10" are similar to the CO₂ refrigeration unit 10 of Fig. 1, but without the high-pressure condensing circuit 13 within the casing of the refrigeration unit. Accordingly, like elements between the CO₂ refrigeration units 10 and 10" will bear like reference numerals.

In the embodiment of Fig. 3, the CO₂ refrigeration units 10" share the high-pressure condensing circuit 13. As in some instances the condensing load of the CO₂ refrigerant is relatively low, it is considered to share amongst at least two refrigeration units a high-pressure condensing

circuit 13. Accordingly, by sharing the high-pressure condensing circuit 13, the CO₂ refrigeration units 10" represent a cost-efficient solution. All refrigeration units 10" are in a heat-exchange relation with the heat-exchange evaporation stage 33 of the high-pressure condensing circuit 13. Although three CO₂ refrigeration units 10" are illustrated in the embodiment of Fig. 3, a high-pressure condensing circuit 13 can be shared by two or more of the CO₂ refrigeration units 10". Moreover, the high-pressure condensing circuit 13 may be in its own rooftop casing, or may be in one of the CO₂ refrigeration units 10" that are part of the network of CO₂ refrigeration units 10" sharing the high-pressure condensing circuit 13.

Referring to Fig. 4, a CO₂ condensation tank is shown at 50. The tank 50 is a pressure vessel receiving gaseous CO₂ from the compression stage 20 and possibly from the heat reclaim stage 26. The gaseous CO₂ is then directed to the heat-exchange evaporation stage 33 of the circuit 13, in which heat from the gaseous CO₂ is absorbed by the refrigerant circulating in the circuit 13. By the heat exchange, the gaseous CO₂ is at least partially liquefied and returns to the tank 50 through line D. Accordingly, liquid CO₂ 51 accumulates in the tank 50, and by gravity accumulates in the bottom of the tank 50, as is illustrated in Fig. 4. Liquid CO₂ 51 supplied from the bottom of the tank 51 is then directed to the evaporation stages 23 and 25. Gaseous CO₂ from the tank 50 may also be directed to a suction of a CO₂ dedicated compressor, by having a pressure-reduction valve 52 or like means between the tank 50 and the dedicated compressor.

In Fig. 4, a schematic view of the tank 50 is provided. Although not shown, it is however pointed out that all suitable valves, pressure controls and/or regulators are provided in order to ensure the heat exchange between the gaseous CO₂ and the refrigerant from the high-pressure refrigeration circuit 13 in the heat-exchange evaporation stage 33.

In order to reduce material costs, it is considered to have the condensation stages 31 and 41 share condenser components in the casing of the refrigeration unit 10, as is illustrated in Fig. 5. For instance, fans, water cooling systems and the like are preferably shared by the coils of the condensation stages 31 and 41.

Referring to Fig. 8, there is illustrated another embodiment of a CO₂ refrigeration unit at 80 similar to the CO₂ refrigeration units 10, 10' and 10". Accordingly, like elements will bear like reference numerals. The CO₂ refrigeration unit 80 has a medium-temperature compression stage 81, the suction of which collects refrigerant from the medium-temperature evaporation stage 23. The CO₂ refrigerant is in a suitable gas/liquid state, having been expanded via an expansion stage 82 prior to reaching the medium-temperature evaporation stage 23, with suitable means (e.g., accumulators, heat exchangers) that may prevent liquid refrigerant from reaching the compression stage 81, and that lower the pressure of refrigerant fed to the compression stage 20/81.

The discharge of the low-temperature compression stage 20 and of the medium-temperature compression stage 81 is then directed to the condensation stage 21, optionally via the heat reclaim stage 26, as described above for the CO₂ refrigeration units 10, 10' and 10". Alternatively, the discharge of the compression stages 20 and/or 81 may be fed directly to the heat-exchange evaporation stage 33 via line 83 prior to reaching the condensation reservoir 21 in a liquid state. This configuration may also be used for the CO₂ refrigeration units 10, 10' and 10". Although not shown, the CO₂ refrigeration unit 80 may be equipped with a defrost circuit, as set for above for the CO₂ refrigeration units 10, 10' and 10".

Referring to Fig. 9, there is illustrated another embodiment of a CO₂ refrigeration unit at 90 similar to the CO₂ refrigeration units 10, 10', 10" and 80. Accordingly, like elements will bear like reference numerals. The CO₂

refrigeration unit 90 has a defrost reservoir 91, positioned between the suction of the dedicated compression stage 20B and the low-temperature evaporation stage 25. The suction of the dedicated compression stage 20B is typically on top of the defrost reservoir 91, such that CO₂ refrigerant in a gas state is collected thereby.

In order to periodically flush the liquid contents of the defrost reservoir 91, a line 92 extends from the discharge of the compression stages 20A and 20B, with appropriate valves (not shown). The line 92 is selectively opened to direct the discharge into the defrost reservoir 91, and flush the liquid CO₂ refrigerant into the condensation reservoir 21 via line 93 (also provided with appropriate valves).

It is observed that pressure-reducing valve 94 may be connected to a discharge line of the compression stages 20A and/or 20B, so as to ensure that the defrost refrigerant is fed to the evaporators of the evaporation stages 23/25 at a higher pressure than in the condensation reservoir 21. This is to ensure a flow of defrost refrigerant back into the refrigeration circuit after defrost.

In Fig. 9, both the pressuring means 22 and the expansion stage 24 are in the casing of the CO₂ refrigeration unit 90. This configuration is therefore well suited for retro-fitting existing evaporators to the refrigeration unit 90, as lines are drawn from the casing to the evaporators. The various configurations of the CO₂ refrigeration unit 90 may be used for the CO₂ refrigeration units 10, 10', 10" and/or 80.

The CO₂ refrigeration units 10, 10', 10", 80 and 90 are equipped with a processing unit that ensures the proper operation of the refrigeration cycles.

According to one embodiment, the processing unit controls the operation of the electrically powered components of the refrigeration units 10, 10', 10", 80 and 90. The processing unit will be programmed with procedures to operate the CO₂ refrigeration units 10, 10', 10", 80 and

90 in a cost-effective fashion, while optimizing energy consumption.

In an embodiment, all fans of the evaporators of the evaporation stages 23 and 25 are controlled by the processor unit of the CO₂ refrigeration units 10, 10', 10", 80 and 90. According to this feature, fans are automatically turned off when an evaporator of the stages 23 and/or 25 goes into a defrost cycle, as commanded by the processor unit which also controls the operation of defrost cycles. Accordingly, all defrost commands are centralized through the processor unit.

The processor unit is also programmed to restart the components of the CO₂ refrigeration units 10, 10' and 10" in case of a power outage. According to one sequence of command, the fans of the evaporator stages 23 and 25 in a refrigeration cycle are turned on gradually to avoid a high load on the CO₂ refrigeration circuit 12, so as to maintain the pressure of CO₂ below the relief threshold. Moreover, the pressure of CO₂ is monitored throughout the refrigeration circuit 12 to avoid having the CO₂ pressure go above the relief threshold. In an example, if the CO₂ pressure in the tank 50 is too high, the processing unit may stop some of the fans in the evaporation stages 23 and 25 to reduce the load, and avoid the relief of CO₂. The operator of the system is warned by an alarm of the high pressure. In case of an extended power outage, the processor unit of the CO₂ refrigeration units 10" of Fig. 3 may be operated in a preservation mode from the limited power supply of a power generator. In such a case, it is considered to operate the refrigeration units 10" one after the other, each for a given amount of time, so as to optimize the use of the limited power supply of the power generator. In these cases, it is considered to operate the oil-free magnetic-bearing compressors of the compression stages 20 and 30, and potentially of the compression stage 40, and to operate the compressors at the minimum.

In order to minimize energy consumption, it is considered to have variable compressors of the CO₂ refrigeration units 10, 10', 10", 80 and 90 for some or all compression stages, namely stages 20, 30 and 40. Also, the CO₂ refrigeration circuit 12 is typically provided with pressure relief valves to exhaust CO₂ above a given pressure threshold. In the event of a power outage, the restart of the compression stage 20 may cause the CO₂ pressure to be above the relief threshold, whereby it is preferred to use variable compressors in the compression stage 20 to gradually build the pressure in the circuit 12 so as to avoid the relief of CO₂. The temperature of the CO₂ is controlled by the variation of the speed of the compressors from the compression stage 20. Moreover, the compressors of the stages 20, 30 and/or 40 preferably operate in floating control so as to produce a floating head pressure, and minimize energy consumption.

Although the CO₂ refrigeration units of Figs. 1 to 3 show at least two of the CO₂ refrigeration circuit 12, the high-pressure condensing circuit 13 cascaded with the CO₂ refrigeration circuit 12, and the ventilation circuit 14 in the same roof-top casing, it is considered to have the three circuits 12, 13 and 14 each in its own casing.

The CO₂ refrigeration units 10, 10', 10", 80 and 90 described previously are used in different climates, but are particularly well suited for warmer climates, in that the CO₂ defrost circuit can be operated at relatively low pressures. More specifically, the pressure of the CO₂ defrost refrigerant is typically below 700 Psi, but preferably ranges between 300 and 425 Psi. These low pressures result from the low pressures in the refrigeration circuit, and more particularly in the condensation stage 21. The CO₂ refrigerant is kept at a low pressure by the heat-exchange relation with the secondary refrigerant in the high-pressure condensing circuit 13.

Referring to Fig. 6, an alternative embodiment of the high-pressure condensing circuit is illustrated at 13'.

The primary function of the high-pressure condensing circuit 13' is to cool the CO₂ refrigerant of the CO₂ refrigeration circuit 12.

In one embodiment, the compressors of the
5 compression stage 30 are oil-free magnetic-bearing compressors, which operate under specific conditions. In such a case, it is required to maintain the pressure of the refrigerant above given thresholds. Accordingly, an optional loop featuring a heat exchanger 60 is provided in
10 the circuit 13' to increase the pressure at the compression stage 30. The loop has a valve 61 that directs hot refrigerant from the discharge of the compression stage 30 to the heat exchanger 60 via lines 62. In the heat exchanger 60, the hot refrigerant is in heat-exchange with
15 cold refrigerant exiting the condensation stage 31. The cold refrigerant exiting the condensation stage 31 is directed to the heat exchanger 60 via line 63 to absorb heat from the hot refrigerant, and then reaches the suction line of the compression stage 30, thereby mixing with refrigerant
20 exiting from the evaporation stage 33, to increase the pressure in the suction line. As illustrated in Fig. 6, by way of example, a valve 63' such as an expansion valve is provided to adjust the pressure prior to the heat exchanger 60. The valve 63' represents one of numerous other
25 possibilities for controlling the pressure in the heat exchanger 60. The hot refrigerant exiting the heat exchanger 60 is then returned upstream of the condensation stage 31, via line 62.

It is also considered to provide heat reclaim 64.
30 In an example, heat reclaim 64 is a heat exchanger by which a refrigerant such as glycol absorbs heat from the refrigerant of the condensing circuit 13'. A glycol circuit may then circulate hot glycol through the facilities, for instance for an auxiliary heating system.

35 Referring to Fig. 10, there is provided an additional pressure-maintaining line 100 extending from the discharge of the compression stage 30 to the suction of the

compression stage 30. A control valve 101 is provided in the line 100 for appropriate control of the flow of refrigerant. The pressure-maintaining line 100 ensures that a suitable pressure is maintained at the suction of the
5 compression stage 30. As some types of compressors (e.g., oil-free magnetic compressors) stop operating below a given pressure, the pressure-maintaining line 100 keeps the compression stage 30 in operation.

Referring to Fig. 11, an expansion arrangement is
10 generally shown 110, and is particularly well suited for any of the CO₂ refrigeration units 10, 10', 10", 80 and 90, with suitable modifications. As illustrated in the CO₂ refrigeration unit 90 of Fig. 9, the expansion stage 24 is in the casing of the units 10, 10', 10", 80 or 90. In the
15 expansion arrangement 110, at least one of the expansion valves 24 is shared by different evaporators 25. More specifically, a line 111 extends from the expansion valve 24 to a plurality of the evaporators 25, with a balancing valve 112 being provided upstream of each evaporator 25, to ensure
20 that the evaporators 25 are fed with CO₂ refrigerant at similar conditions. In the event that defrost refrigerant is subsequently fed to any one of the evaporators 25, a bypass line with, for instance, a check valve 113 is provided upstream of the evaporators 25. It is pointed out
25 that the expansion valve 24 may be out of the casing, and in proximity to the evaporators 25.

CLAIMS:

1. A refrigeration unit comprising:
 - a CO₂ refrigeration circuit having a CO₂ compression stage in which CO₂ refrigerant is compressed, a CO₂ condensation stage having a tank in which CO₂ refrigerant is accumulated in a liquid state, at least one of pressuring means and an expansion stage to direct the CO₂ refrigerant from the CO₂ condensation stage to a CO₂ evaporation stage in which CO₂ refrigerant absorbs energy to refrigerate;
 - a condensation circuit having a second refrigerant being circulated between a second compression stage, a second condensation stage, a second expansion stage and a second evaporation stage;
 - a heat-exchanger unit by which the CO₂ refrigerant from the CO₂ refrigeration circuit is in heat exchange with the second refrigerant in the second evaporation stage such that the second refrigerant absorbs heat from the CO₂ refrigerant to at least partially liquefy the CO₂ refrigerant for the CO₂ condensation stage; and
 - a defrost circuit directing defrost CO₂ refrigerant from the CO₂ compression stage to the CO₂ evaporation stage to defrost at least one evaporator of the CO₂ evaporation stage, the defrost CO₂ refrigerant being subsequently returned to the CO₂ refrigeration circuit.
2. The refrigeration unit according to claim 1, wherein a discharge of the CO₂ compression stage is fed to the heat-exchanger unit for releasing heat to then reach the tank of the CO₂ condensation stage.
3. The refrigeration unit according to claim 1, wherein the CO₂ evaporation stage has at least medium-temperature evaporators and low-temperature evaporators, with a line directing CO₂ refrigerant exiting the low-temperature evaporators to the CO₂ compression stage, and

with the pressuring means upstream of the medium-temperature evaporators to feed CO₂ refrigerant to the medium-temperature evaporators, with another line directing CO₂ refrigerant exiting the medium-temperature evaporators to the CO₂ condensation stage.

4. The refrigeration unit according to claim 1, wherein the CO₂ evaporation stage has at least medium-temperature evaporators and low-temperature evaporators, with a line directing CO₂ refrigerant exiting the low-temperature evaporators to the CO₂ compression stage, and with the expansion stage upstream of the medium-temperature evaporators to feed CO₂ refrigerant to the medium-temperature evaporators, with another line directing CO₂ refrigerant exiting the medium-temperature evaporators to the CO₂ compression stage.

5. The refrigeration unit according to claim 1, further comprising a defrost reservoir between the CO₂ evaporation stage and the CO₂ compression stage to collect the defrost CO₂ refrigerant exiting the defrost circuit, a suction of the CO₂ compression stage connected to the defrost reservoir to collect CO₂ refrigerant in a gas state for the CO₂ refrigeration circuit.

6. The refrigeration unit according to claim 5, wherein a discharge line extends from the CO₂ compression stage to the defrost reservoir to selectively flush CO₂ refrigerant from the defrost reservoir through another line extending from the defrost reservoir to the tank in the CO₂ condensation stage.

7. The refrigeration unit according to claim 1, further comprising at least one dedicated compressor in the CO₂ compression stage to collect at least part of the defrost CO₂ refrigerant exiting the defrost circuit, to

compress and discharge the defrost CO₂ refrigerant to the CO₂ refrigeration circuit.

8. The refrigeration unit according to claim 1, further comprising a pressure-reducing valve on a discharge line of the CO₂ compression stage, downstream of a defrost line feeding defrost CO₂ refrigerant to the defrost circuit, to maintain a pressure of the CO₂ refrigerant in the CO₂ refrigeration circuit downstream of the pressure-reducing valve lower than the pressure of the defrost CO₂ refrigerant.

9. The refrigeration unit according to claim 1, wherein the defrost CO₂ refrigerant is circulated in the CO₂ evaporation stage of the defrost circuit at a pressure below 700 Psi.

10. The refrigeration unit according to claim 9, wherein the defrost CO₂ refrigerant is circulated in the CO₂ evaporation stage of the defrost circuit at a pressure between 300 and 425 Psi.

11. The refrigeration unit according to claim 1, further comprising a heat reclaim stage in a discharge line of the CO₂ compression stage to reclaim heat from the CO₂ refrigerant.

12. The refrigeration unit according to claim 11, wherein the heat reclaim stage comprises a coil in a ventilation duct to heat ventilation air.

13. The refrigeration unit according to claim 1, wherein the condensation circuit has a pressure-maintaining line extending from a discharge of the second compression stage to a suction of the second compression stage, the pressure-maintaining line being selectively opened to

maintain a minimum operating pressure at a suction of the second compression stage.

14. The refrigeration unit according to claim 1, wherein the condensation circuit has a second heat-exchanger by which the second refrigerant exiting the second compression stage selectively heats the second refrigerant exiting the second condensation stage to subsequently feed the second refrigerant exiting the second condensation stage directly to the second compression stage.

15. The refrigeration unit according to claim 1, further comprising a line extending from the CO₂ evaporation stage to the CO₂ condensation stage to direct defrost CO₂ refrigerant from the defrost circuit to the refrigeration circuit.

16. A refrigeration unit comprising:

a casing;

a CO₂ refrigeration circuit having a CO₂ compression stage in which CO₂ refrigerant is compressed, a CO₂ condensation stage having a tank in which CO₂ refrigerant is accumulated in a liquid state, at least one of pressuring means and an expansion stage to direct the CO₂ refrigerant from the CO₂ condensation stage to a CO₂ evaporation stage in which CO₂ refrigerant absorbs energy to refrigerate, with at least the CO₂ compression stage, and the CO₂ condensation stage being in the casing;

a condensation circuit having a second refrigerant being circulated between a second compression stage, a second condensation stage, a second expansion stage and a second evaporation stage, at least the second compression stage, the second expansion stage and the second evaporation stage being in the casing; and

a heat-exchanger unit in the casing by which the CO₂ refrigerant from the CO₂ refrigeration circuit is in heat exchange with the second refrigerant in the second

evaporation stage such that the second refrigerant absorbs heat from the CO₂ refrigerant to at least partially liquefy the CO₂ refrigerant for the CO₂ condensation stage.

17. The refrigeration unit according to claim 16, further comprising a defrost circuit directing defrost CO₂ refrigerant from the CO₂ compression stage to the CO₂ evaporation stage to defrost at least one evaporator, the defrost CO₂ refrigerant being subsequently returned to the CO₂ refrigeration circuit.

18. The refrigeration unit according to claim 16, wherein the at least one of pressuring means and expansion stage are in the casing.

19. The refrigeration unit according to claim 16, further comprising a ventilation circuit in which circulates a third refrigerant between a third compression stage, a third condensation/gas cooling stage, a third expansion stage and a third evaporation stage, at least the third compression stage, the third condensation/gas cooling stage, and the third expansion stage being in the casing, with the third evaporation stage adapted to be in a ventilation duct to absorb heat from ventilation air.

20. The refrigeration unit according to claim 19, further comprising a heat reclaim stage in a discharge line of the CO₂ compression stage to reclaim heat from the CO₂ refrigerant, the heat reclaim stage comprising a coil adapted to be in said ventilation duct to heat ventilation air.

21. The refrigeration unit according to claim 16, further comprising at least an other one of the refrigeration unit in another one of the casing, the other one of the refrigeration unit being without one of the condensation circuit, and being in heat-exchange relation

with the heat-exchange unit of the first one of the refrigeration unit.

22. A refrigeration unit of the type having a CO₂ refrigeration circuit with a CO₂ compression stage in which CO₂ refrigerant is compressed, a CO₂ condensation stage having a tank in which CO₂ refrigerant is accumulated in a liquid state, an expansion stage to direct the CO₂ refrigerant from the CO₂ condensation stage to a CO₂ evaporation stage in which CO₂ refrigerant absorbs energy to refrigerate, the CO₂ evaporation stage having at least two evaporators, the refrigeration unit comprising at least one line connected from the CO₂ condensation stage to one expansion valve of the expansion stage, the line diverging into at least two lines each connected to a balancing valve and an own one of the evaporators, such that CO₂ refrigerant expanded by the one expansion valve is directed to the at least two evaporators through the balancing valves.

23. The refrigeration unit according to claim 22, wherein the expansion stage is in a casing with the CO₂ compression stage and the CO₂ condensation stage at a distal location from the CO₂ evaporation stage.

24. The refrigeration unit according to claim 23, wherein the refrigeration unit is retrofitted to existing evaporators.

25. The refrigeration unit according to claim 22, further comprising a defrost circuit directing defrost CO₂ refrigerant from the CO₂ compression stage to the CO₂ evaporation stage to defrost the evaporators, the defrost CO₂ refrigerant being subsequently returned to the CO₂ refrigeration circuit.

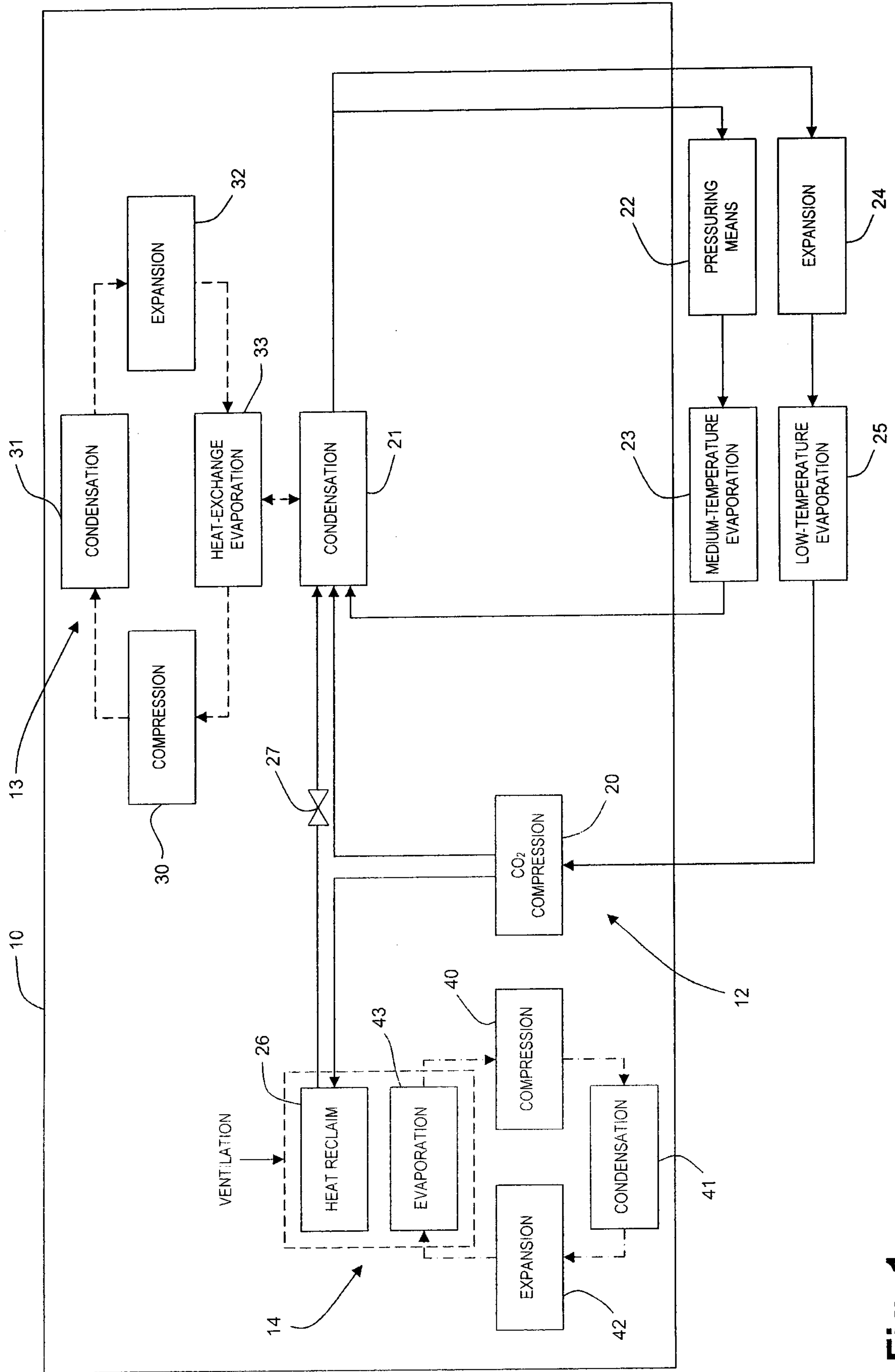

Fig. 1

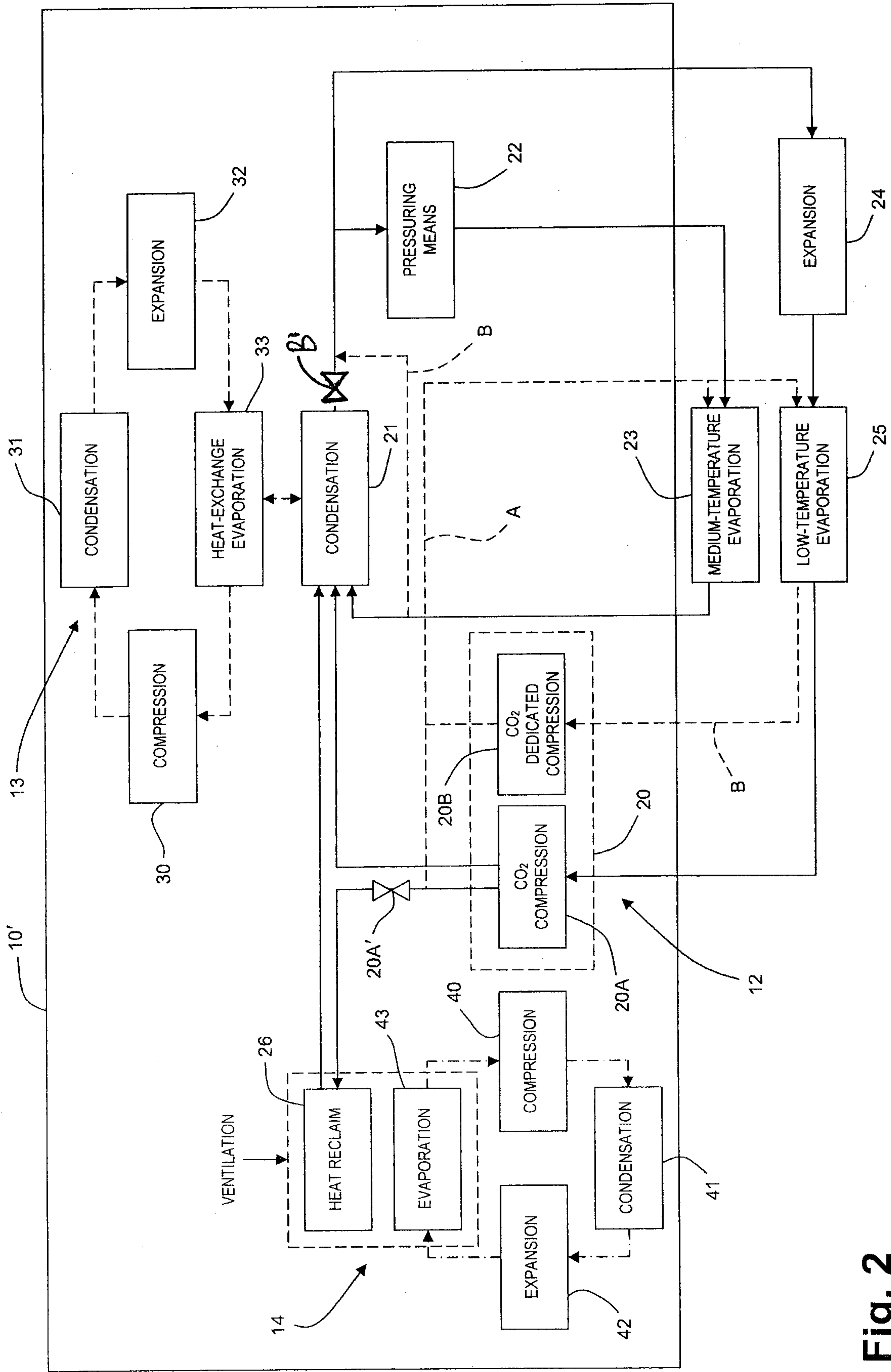

Fig. 2

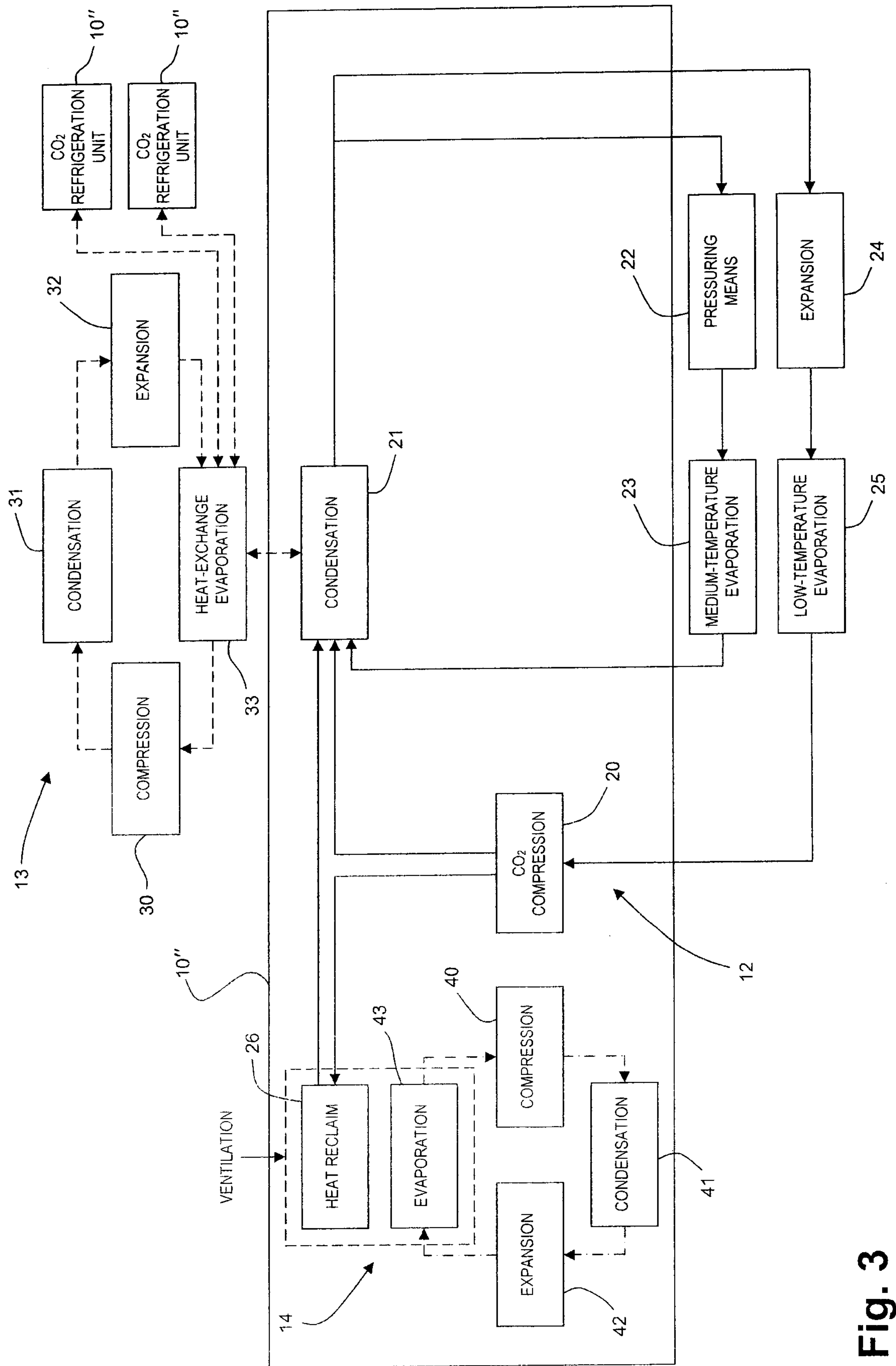

Fig. 3

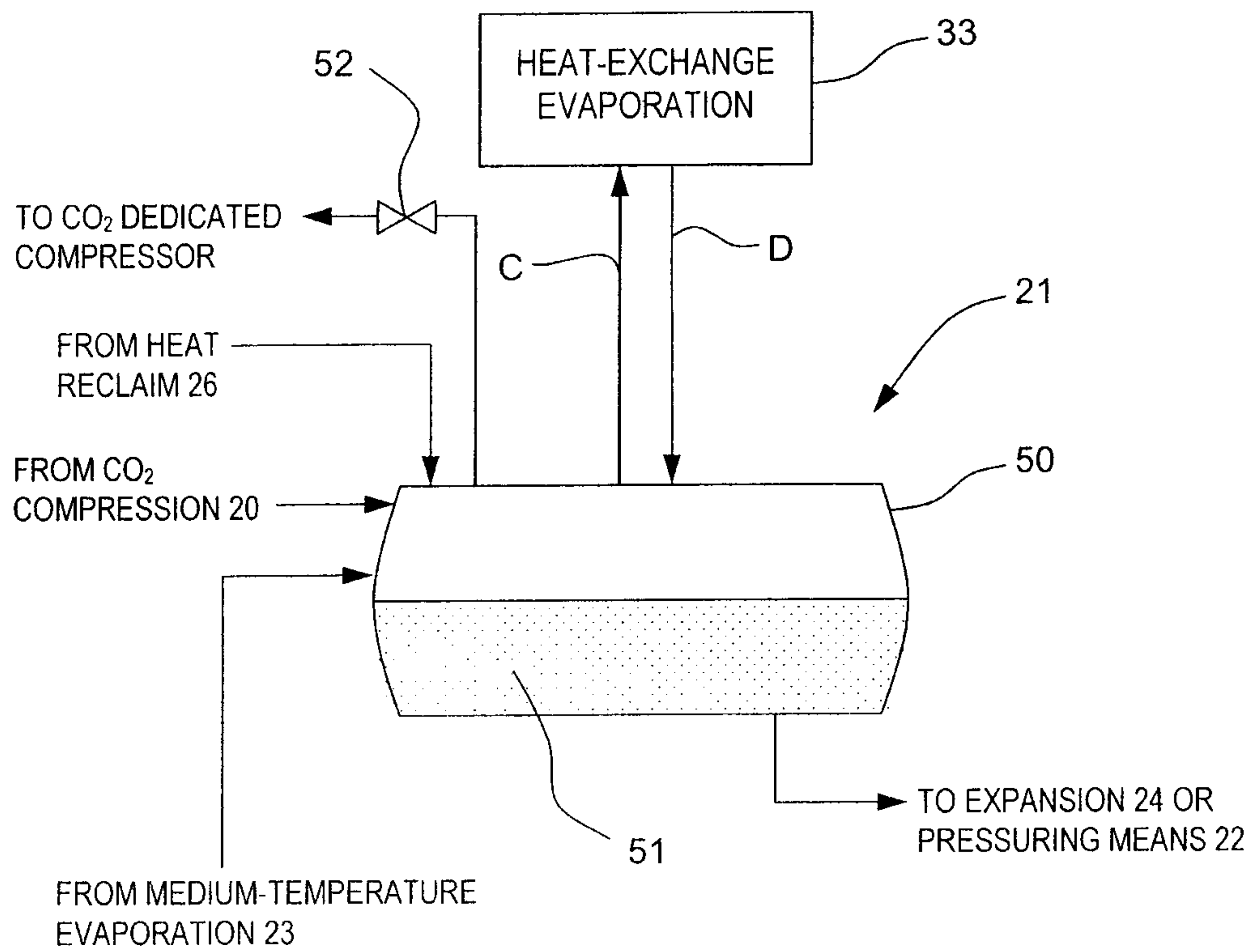

Fig. 4

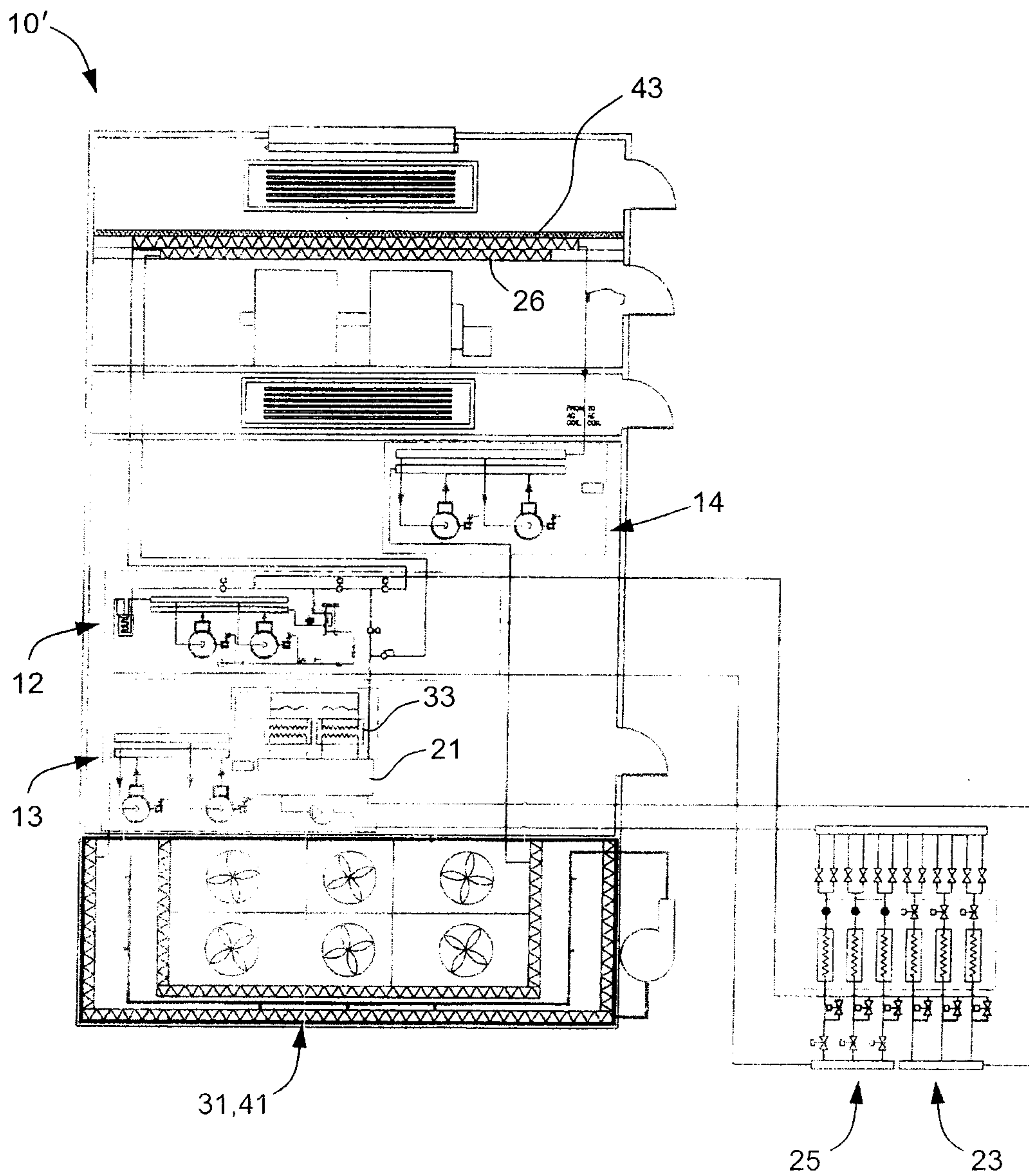

Fig. 5

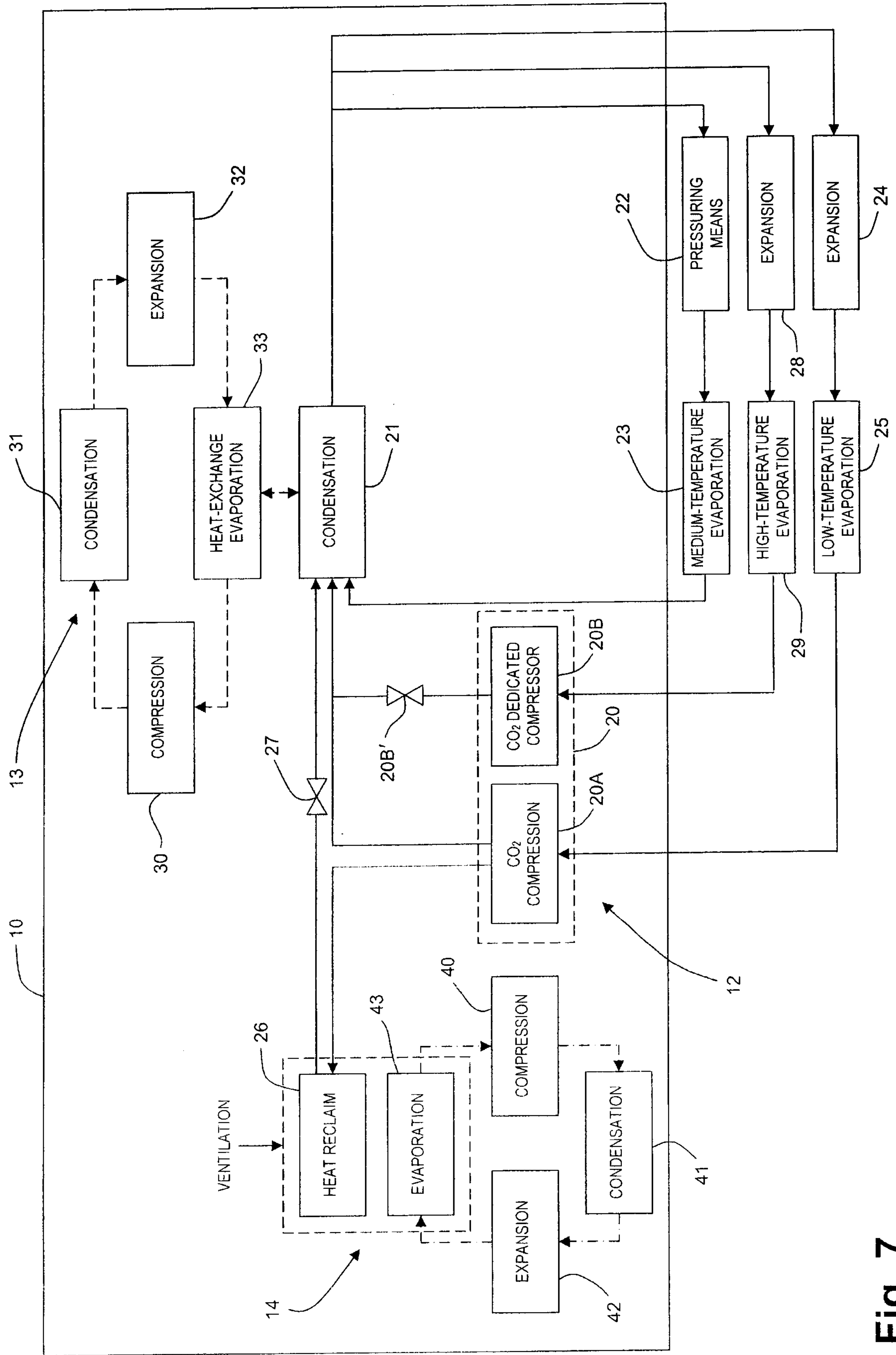

Fig. 7

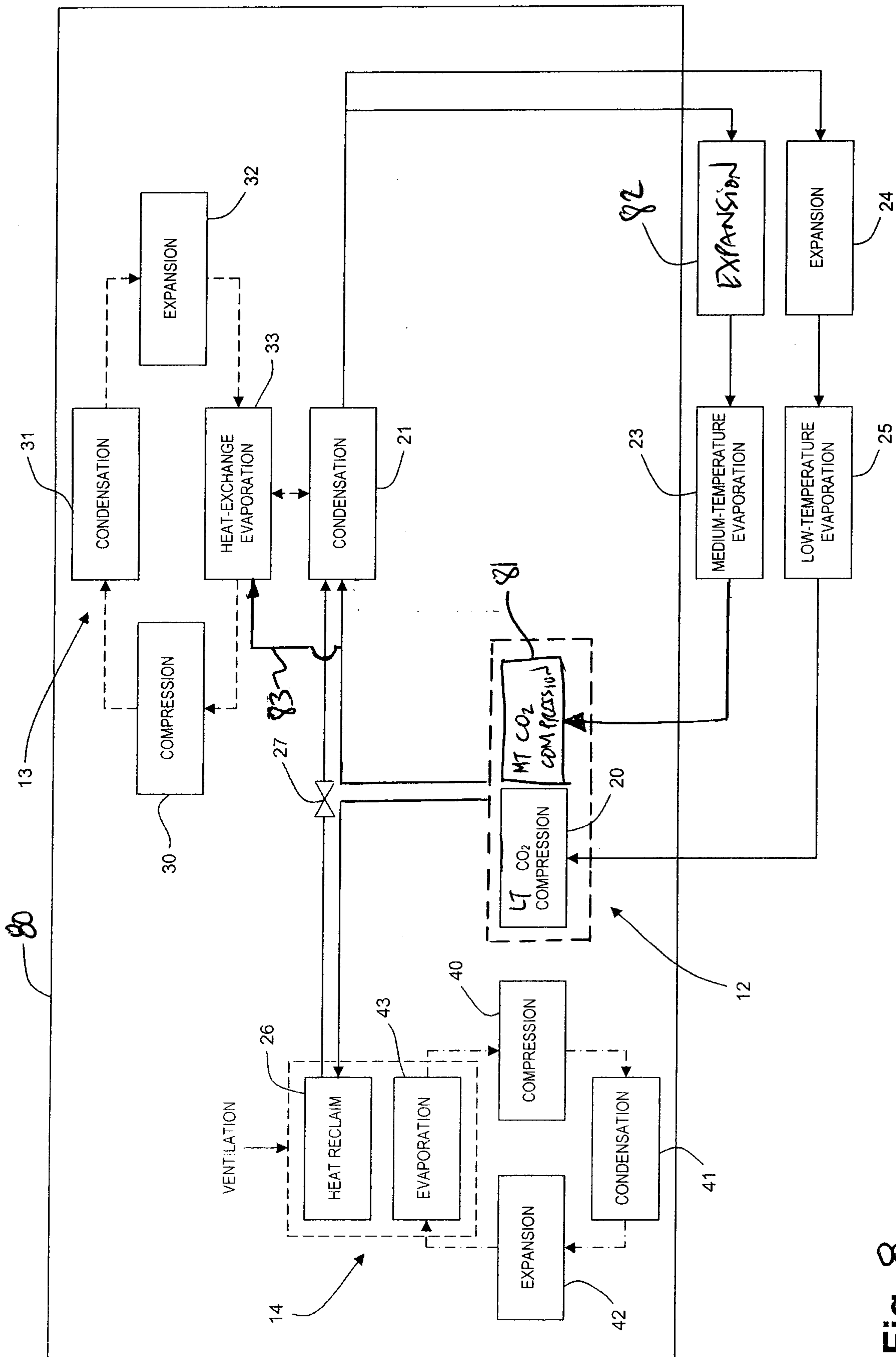

Fig. 8

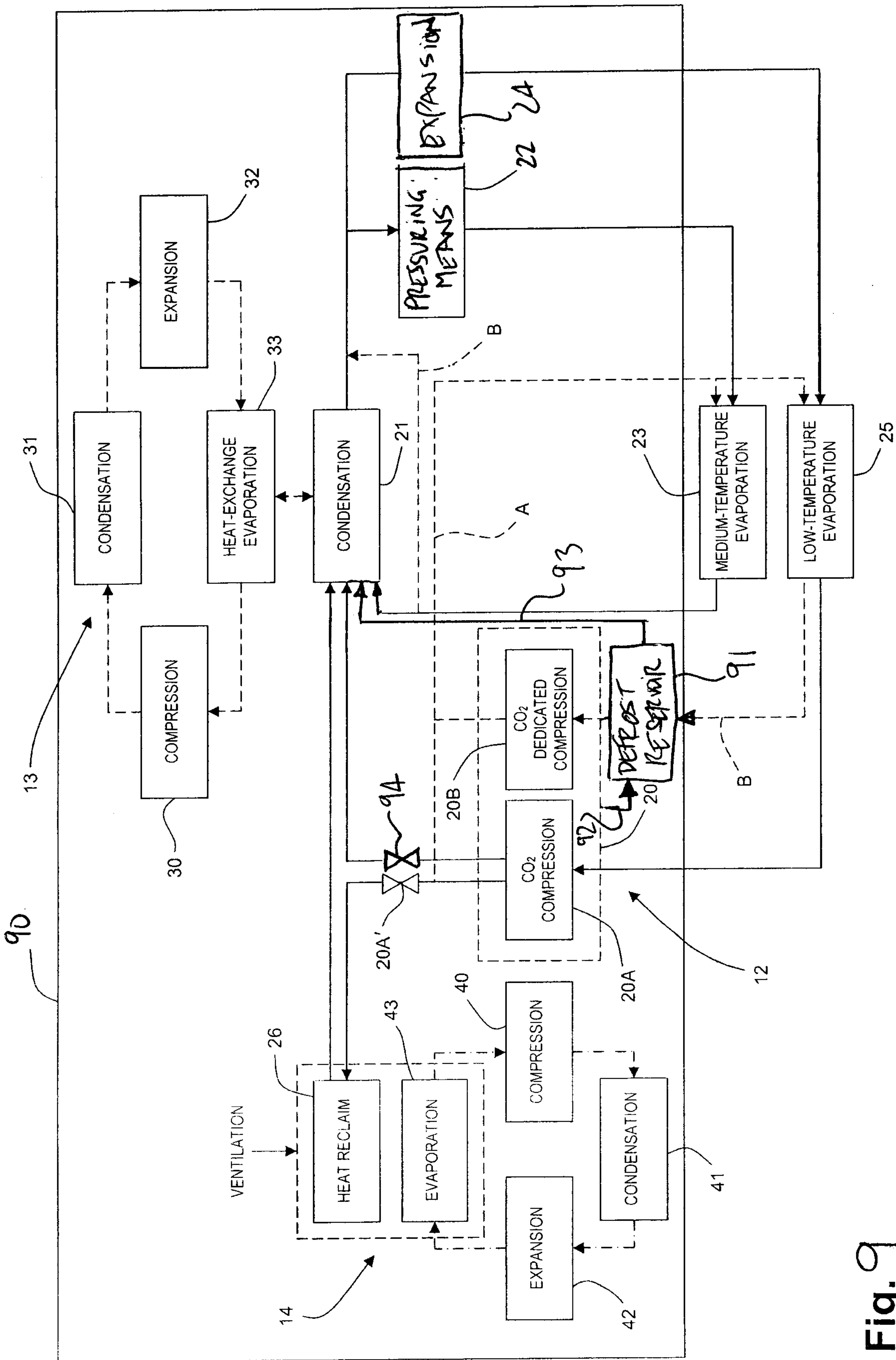

Fig. 9

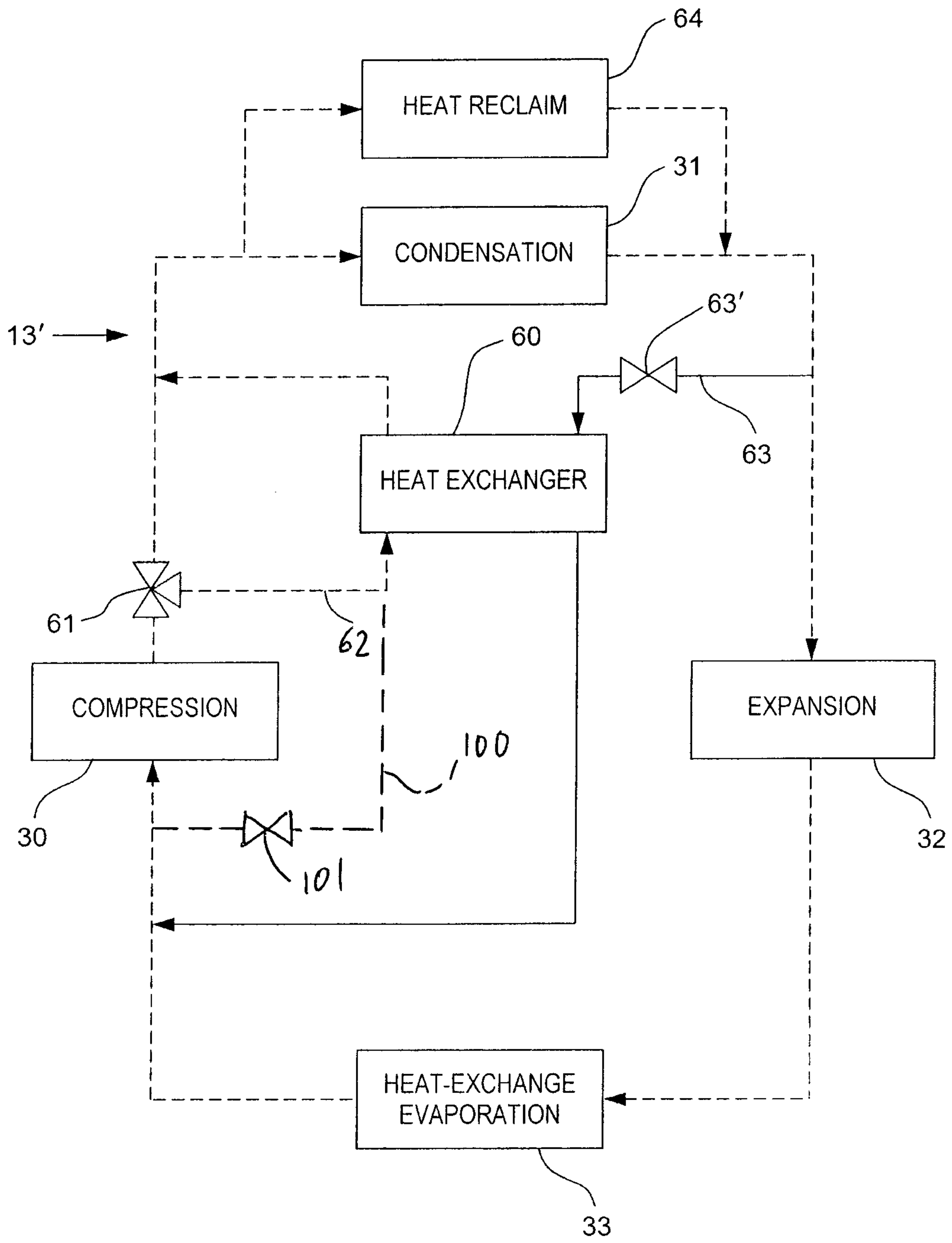

Fig. 10

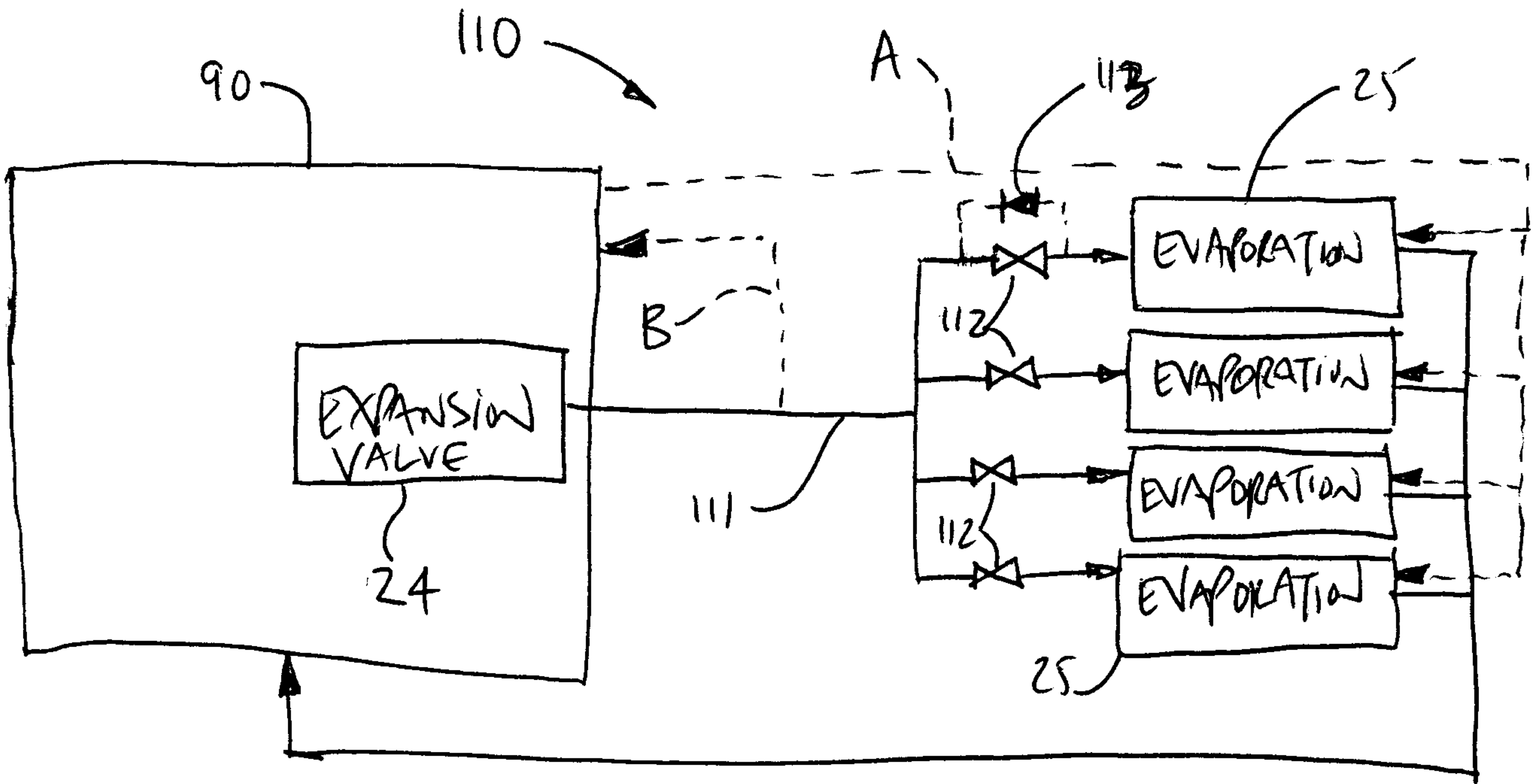

Fig-11

