

[54] **PIEZOELECTRIC IGNITION DEVICE**
 [75] Inventors: **Johann Schroder, Aachen; Hans Gunther Ganser, Stolberg; Heinrich Oepen, Gressemich, all of Germany**
 [73] Assignee: **U.S. Philips Corporation, New York, N.Y.**
 [22] Filed: **May 30, 1972**
 [21] Appl. No.: **258,128**

3,271,624 9/1966 Kingma et al..... 317/81
 3,298,421 1/1967 Tezuka et al. 317/81 X
 3,384,786 5/1968 Oyamada et al..... 317/81 X
 3,449,637 6/1969 Suzuki 317/81
 3,464,531 9/1969 Herr et al. 310/8.3 X
 3,523,201 8/1970 Good 310/8.7

Primary Examiner—Volodymyr Y. Mayewsky
Attorney—Frank R. Trifari

[30] **Foreign Application Priority Data**
 June 18, 1971 Germany..... P 21 30 221.6

[57] **ABSTRACT**

[52] U.S. Cl..... 317/81, 310/8.7, 317/DIG. 11
 [51] Int. Cl..... F23q 13/00, F23q 3/01
 [58] **Field of Search**..... 317/DIG. 11, 81;
 310/8.3, 8.7; 431/255

A piezo-electric ignition device which comprises a housing in which are incorporated one behind the other a piezo-electric element, a hammer and a spring cooperating with the hammer. A plastic-elastic damping disk is arranged between the hammer and the element. Braking means inhibit the movement of the hammer in the direction of the spring.

[56] **References Cited**
UNITED STATES PATENTS
 2,717,589 9/1955 Harkness 317/DIG. 11

9 Claims, 1 Drawing Figure

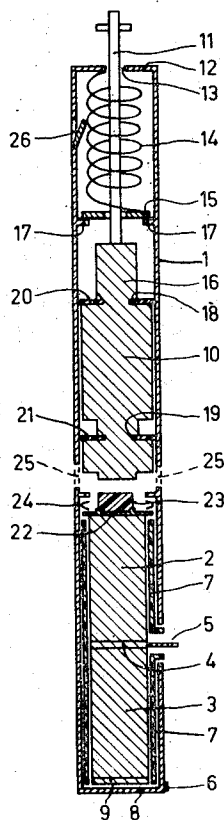

PATENTED SEP 11 1973

3,758,827

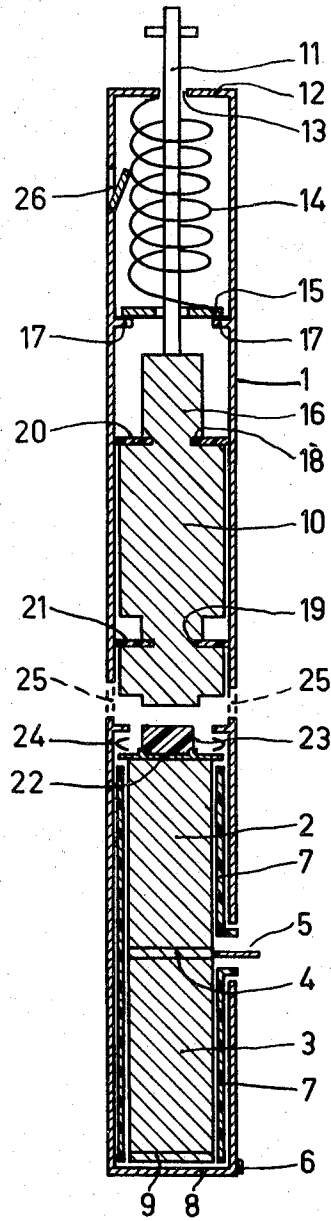

PIEZOELECTRIC IGNITION DEVICE

This invention relates to a piezoelectric ignition device and more particularly to a piezoelectric ignition device suitable for operating a plurality of combustion flash lamps.

It is known to ignite a series of combustion flash bulbs which are incorporated in an electric circuit by the short-lasting application of a high voltage. In this case the lamps are arranged in parallel and when applying a voltage, that one lamp which has the lowest ignition voltage will ignite first and cause a short-circuit such that the voltage between the poles of the other lamps drops to a very low value. The lamps are constructed so that after combustion they no longer form part of the electric circuit (i.e., appear as an open circuit).

For realizing a short-lasting high voltage it has been proposed to use a piezo-electric ignition device of the type which is used in cigar lighters.

This known ignition device is formed by a preferably cylindrical housing in which at least one piezoelectric element is accommodated and in which are furthermore incorporated a hammer and a spring co-operating with said hammer for applying a striking pulse to a piezo-electric element. The electric energy produced by a stroke of the hammer on the piezo-electric element produces a spark between the ends of two electrodes connected to the piezoelement as a result of which a combustible gas can be ignited. Embodiments are known of this known ignition device in which the cylinder surface of the piezo-element is surrounded by a tubular jacket of electrically insulating synthetic material present inside the housing and in which at least one of the end faces of the piezo element cooperates with an anvil.

The known piezo-electric ignition devices, however, cannot be used as such for the successive ignition of a number of combustion flash bulbs incorporated in an electric circuit for the following reasons.

As a result of the application of the striking pulse, the voltage rises so rapidly that during the time which elapses between the instant at which the breakdown voltage of a first lamp is achieved and the instant at which the circuit is shortcircuited as a result of said breakdown, the voltage can increase to such an extent that the breakdown voltage of a second lamp is also reached so that two lamps are ignited.

Furthermore, in the known ignition devices, approximately 1 millisecond after the application of the pulse a short-lasting increase of the voltage is observed between the electrodes. Said second voltage pulse is probably the result of resonance phenomena in the device in which the hammer impacts on the piezo-electric element for a second time. As a result of said second voltage pulse, a second lamp may be ignited.

It is object of the invention to provide a piezo-electric ignition device which does not exhibit said phenomena and is consequently suitable for use as an ignition device for combustion flash bulbs.

A piezo-electric ignition device according to the invention is constituted by a preferably cylindrical housing in which at least one piezo-electric element is accommodated and in which furthermore a hammer is incorporated which under the action of a spring can supply a striking pulse to the piezo element. Furthermore, a disk is provided between the hammer and the piezo

element. This disk is formed from a material which is softer than the material of the hammer, the disk is formed from a plastic elastic material. A further feature of the invention is that braking means are present which counteract the movement of the hammer in the direction away from the piezo-element.

By the use of a disk between the hammer and the piezo element it is achieved that the voltage increases more slowly.

It has been found in experiments that upon applying a pulse to the piezo element, if no disks were present, the electric voltage reaches its maximum value after approximately 5 μ sec. When using a damping disk made of polyvinylchloride, said time is increased to approximately 30 μ sec.

The material of the disk should have plastic-elastic properties. To be considered are synthetic materials which show a high degree of stress relaxation at room temperature, for example, softened polyvinylchloride and various polyolefines and butyl rubbers.

From the Swiss patent specification No. 464,832 it is known per se to provide a piezo-electric ignition device with an elastic rubber disk between the anvil and the bottom of the housing. As a result of the choice of the material of the disk, an elastic rubber, and the place where the disk is provided, the above-mentioned resonance phenomena occur to an intensified extent.

As a result of the provision of the braking means, it is achieved that the hammer, after applying the pulse, maintains its position pressed against the piezo-electric element so that a second pulse is prevented.

A favourable embodiment of the ignition device according to the invention is characterized in that the braking means are formed by at least one ring which is secured to the hammer and is preferably manufactured from a synthetic resin, the outer circumference of said ring engaging the inner wall of the housing. The ring is secured to the hammer in such manner that the resistance which the hammer experiences during its movement in the direction of the piezo-electric element is smaller than during its movement in the opposite direction. An additional advantage of said measure is that the rings constitute a good guide for the hammer in the housing.

A further embodiment of the device according to the invention is characterized in that the braking means are formed by one or more check valves arranged in the wall of the housing. If such a valve is provided on the side of the hammer remote from the piezo-electric element and only permits a small flow of air from outside the housing to the interior, the air will be compressed when the hammer is moved in the direction of the valve. As a result of this the said movement is impeded.

The invention will be explained in greater detail with reference to the accompanying drawing of a preferred embodiment thereof.

The ignition device is constituted by a cylindrical metal housing 1 which comprises a hammer 10 and two piezo-electric crystals 2 and 3. A plate 4 to which an electrode 5 is connected is arranged between the crystals 2 and 3. A second electrode 6 is present on the outer wall of the metal housing 1. The piezo-electric crystals 2 and 3 are surrounded by a cylindrical jacket 7 of an insulating material. An anvil 9 is present between the bottom 8 of the housing 1 and the crystal 3.

The hammer 10 comprises a stem 11 which projects through an aperture 13 recessed in the bottom 12. The

hammer 10 can be moved in the direction of the bottom 12 by means of said stem against the resilient action of the spring 14. The spring 14 is supported by a ring 15 which can be moved axially by the part 16 of the hammer 10 and which in its extreme position bears against the studs 17 of the housing 1.

The stem 11 furthermore comprises a locking device, not shown in the drawing, with which the hammer 10 can be locked in its position in which the spring 14 is tensioned.

The hammer 10 comprises two annular recesses 18 and 19 in which the rings 20 and 21, respectively, manufactured from a synthetic material fit, in a clamping manner. The outer circumferences of said rings engage the inner wall of the housing 1 and thus constitute a guide for the hammer 10. From the shape of the hammer it appears that the outer circumference of each ring can be bent in the direction of the stem 11, while bending in the opposite direction is impossible. As a result of this the frictional forces between the rings and the housing, when the hammer is moved in the direction of the piezo-crystals, is significantly smaller than when moving the hammer in the opposite direction.

A plate 22 is provided on the piezo-electric crystal 2, on which plate a damping disk 23 is secured which in this embodiment of the invention is manufactured from polyvinylchloride. The plate 22 is forced against the crystal 2 by means of the spring 24. Near the damping disk 23, desaeration holes 25 are recessed in the wall of the housing, as a result of which it is prevented that the stroke of the hammer is damped by compression of the air.

The wall of the housing 1 furthermore comprises a valve 26 which permits only an airflow from outside the housing to the interior. As a result of this the air in the space above the hammer is slightly compressed when the hammer is moved in the direction of the valve 26 so that said movement is braked. Of course, the space above the hammer is not entirely closed in an airtight manner.

What is claimed is:

1. A piezoelectric ignition device comprising, a cylindrical housing, an electrically insulated piezoelectric element having electrodes and being disposed within said housing, a hammer movable within said housing towards the piezoelectric element, a spring arranged to urge the hammer in a direction to provide a striking pulse to the piezoelectric element, a disk formed of a plastic elastic material which is softer than the material of the hammer and positioned between the piezoelectric element and the hammer, braking means secured to the hammer and in contact with the inner wall of the housing so as to provide a substantially smaller resistance to the movement of the hammer in the direction towards the piezoelectric element than in the opposite

direction away from said element, and opening means for relieving the air pressure developed between the hammer and the piezoelectric element during a striking pulse.

2. An ignition device as claimed in claim 1 wherein said braking means comprise at least one ring member secured to the hammer and made of a synthetic material, the outer circumference of the ring engaging the inner wall of the housing and the ring being secured to the hammer in a manner to provide said smaller resistance to the hammer movement in the direction of the piezoelectric element.

3. An ignition device as claimed in claim 2 wherein said ring is located in an annular recess in the hammer so that the major part of the ring surface closest to the piezoelectric element is supported by the hammer surface whereas a major part of the opposite surface of the ring is unsupported whereby the ring is free to flex when the hammer moves towards the piezoelectric element.

4. An ignition device as claimed in claim 2 further comprising a second ring movable in a direction parallel to the hammer movement and secured to one end of said spring, said second ring being located within the housing so as to be contacted by the hammer for movement thereby in a direction away from the piezoelectric element.

5. An ignition device as claimed in claim 2 wherein said braking means further comprises a second ring member secured to the hammer at an area axially displaced from the first ring and with its outer circumference engaging the inner wall of the housing.

6. An ignition device as claimed in claim 1 further comprising an insulating tube within the housing and with the piezoelectric element located within the insulating tube, and said pressure relieving means comprises an air hole in the housing in the area where the hammer strikes the plastic disk thereby to prevent compression of the air within the housing when the hammer is moved towards the piezoelectric element.

7. An ignition device as claimed in claim 1 wherein the housing is made of an electric conductor material and said electrodes include a first electrode connected to a point on the piezoelectric element and a second electrode connected to the housing, said piezoelectric element having one surface in electric contact with the inner surface of the housing.

8. An ignition device as claimed in claim 1 wherein said braking means comprises at least one check valve arranged in the wall of the housing and located on the side of the hammer that is opposite to the hammer striking face.

9. An ignition device as claimed in claim 2 wherein said disk is composed of polyvinyl chloride.

* * * * *