



INTERNATIONAL APPLICATION PUBLISHED UNDER THE PATENT COOPERATION TREATY (PCT)

(51) International Patent Classification⁶ :

F16L 37/08, 37/084

A1

(11) International Publication Number:

WO 96/24003

(43) International Publication Date:

8 August 1996 (08.08.96)

(21) International Application Number: PCT/EP96/00450

(22) International Filing Date: 2 February 1996 (02.02.96)

(30) Priority Data:

9502177.0	3 February 1995 (03.02.95)	GB
9502176.2	3 February 1995 (03.02.95)	GB
9504310.5	3 March 1995 (03.03.95)	GB
9509955.2	17 May 1995 (17.05.95)	GB
9511416.1	6 June 1995 (06.06.95)	GB
9514539.7	15 July 1995 (15.07.95)	GB
9519811.5	29 September 1995 (29.09.95)	GB

(71) Applicant (for all designated States except US): ARTFORM INTERNATIONAL LIMITED [GB/GB]; Bishop Meadow Road, Loughborough, Leics LE11 ORE (GB).

(72) Inventor; and

(75) Inventor/Applicant (for US only): DAVIDSON, Paul, Anthony [GB/GB]; 3 Little Aston Close, Tytherington, Macclesfield, Cheshire SK10 2UE (GB).

(74) Agent: HALL, Robert, Leonard; Dibb Lupton Broomhead, Fountain Precinct, Balm Green, Sheffield S1 1RZ (GB).

(81) Designated States: AL, AM, AT, AU, AZ, BB, BG, BR, BY, CA, CH, CN, CZ, DE, DK, EE, ES, FI, GB, GE, HU, IS, JP, KE, KG, KP, KR, KZ, LK, LR, LS, LT, LU, LV, MD, MG, MK, MN, MW, MX, NO, NZ, PL, PT, RO, RU, SD, SE, SG, SI, SK, TJ, TM, TR, TT, UA, UG, US, UZ, VN, ARIPO patent (KE, LS, MW, SD, SZ, UG), Eurasian patent (AZ, BY, KG, KZ, RU, TJ, TM), European patent (AT, BE, CH, DE, DK, ES, FR, GB, GR, IE, IT, LU, MC, NL, PT, SE), OAPI patent (BF, BJ, CF, CG, CI, CM, GA, GN, ML, MR, NE, SN, TD, TG).

Published

*With international search report.**Before the expiration of the time limit for amending the claims and to be republished in the event of the receipt of amendments.*

(54) Title: CONNECTORS

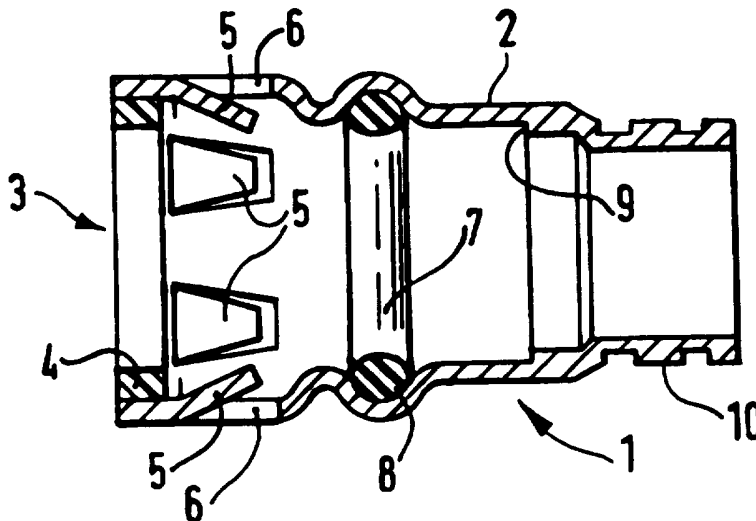

(57) Abstract

This invention relates to connectors (1) and more particularly, to a connector for a tubular member (2), for example, a pipe, a tube, or a rod that is a push fit onto an end of a tubular member. In one embodiment, there is provided a connector (1) between a first tubular member (42) and a second tubular member (45), wherein the first tubular member has an open end adapted to receive the second tubular member in axial sliding engagement therewith, and wherein there is further provided gripping means (43) mounted on the wall of said tubular members and adapted to bear upon the wall of the other tubular member in gripping engagement therewith.

FOR THE PURPOSES OF INFORMATION ONLY

Codes used to identify States party to the PCT on the front pages of pamphlets publishing international applications under the PCT.

AM	Armenia	GB	United Kingdom	MW	Malawi
AT	Austria	GE	Georgia	MX	Mexico
AU	Australia	GN	Guinea	NE	Niger
BB	Barbados	GR	Greece	NL	Netherlands
BE	Belgium	HU	Hungary	NO	Norway
BF	Burkina Faso	IE	Ireland	NZ	New Zealand
BG	Bulgaria	IT	Italy	PL	Poland
BJ	Benin	JP	Japan	PT	Portugal
BR	Brazil	KE	Kenya	RO	Romania
BY	Belarus	KG	Kyrgystan	RU	Russian Federation
CA	Canada	KP	Democratic People's Republic of Korea	SD	Sudan
CF	Central African Republic	KR	Republic of Korea	SE	Sweden
CG	Congo	KZ	Kazakhstan	SG	Singapore
CH	Switzerland	LI	Liechtenstein	SI	Slovenia
CI	Côte d'Ivoire	LK	Sri Lanka	SK	Slovakia
CM	Cameroon	LR	Liberia	SN	Senegal
CN	China	LT	Lithuania	SZ	Swaziland
CS	Czechoslovakia	LU	Luxembourg	TD	Chad
CZ	Czech Republic	LV	Latvia	TG	Togo
DE	Germany	MC	Monaco	TJ	Tajikistan
DK	Denmark	MD	Republic of Moldova	TT	Trinidad and Tobago
EE	Estonia	MG	Madagascar	UA	Ukraine
ES	Spain	ML	Mali	UG	Uganda
FI	Finland	MN	Mongolia	US	United States of America
FR	France	MR	Mauritania	UZ	Uzbekistan
GA	Gabon			VN	Viet Nam

CONNECTORS

This invention relates to connectors, and more particularly, but not exclusively, to a connector for connecting two or more items such as tubular members, for example, pipes, tubes, or rods or other fittings, in which a push-fit arrangement is utilised.

10 Despite a vast number of prior proposals, the connection of hollow tubular members, such as pipes or tubes, to each other, or to fittings such as valves, bends, reducers, or tees, is still a laborious business. Present day fittings for connecting pipes or tubes are
15 relatively expensive and require considerable skill and effort to assemble them in a leak-proof manner, particularly if the pipe or tube is to carry a fluid under pressure. The fittings usually comprise a number of parts, many of which are quite small. These can easily
20 be lost, or dropped, whereupon they can readily be contaminated with dirt and dust leading to inadequate sealing.

One form of known connector, for example, comprises
25 an olive and a plurality of threaded parts which can be assembled together and which, on assembly, force the olive into sealing contact with the pipe. These

connectors are easily loosened by mechanical vibration or thermal cycling, and are prone to leakage.

It has been proposed in GB1520150 and in GB1556008, 5 the entire disclosures of which are incorporated herein by reference, to provide a pipe coupling comprising a first socket portion for receiving a pipe-end as a close sliding fit and a second socket portion with a larger diameter, an end cap secured to the outside of the second 10 socket portion and having a radially inwardly projecting portion with an internal diameter not less than the internal diameter of the first socket portion, a toggle ring housed in the second socket portion adjacent a shoulder between the first socket portion and the second 15 socket portion, and a resilient sealing ring housed between the toggle ring and the inwardly projecting portion of the end cap, which has a skirt internally screw threaded and the outside of the second socket portion is provided with mating screw threads. Whilst 20 this connector can provide a good, leak-tight, push-fit connection, it still consists of several small individual parts and requires careful assembly.

Furthermore, in connecting tubular metal conduits, 25 for example, for carrying electrical wiring and cabling, a strong, but not necessarily fluid-tight, connection is required. Hitherto, connections for such electrical conduits have required the provision of metal screw

fittings which are either cast or injection moulded, and then machined. Such fittings are relatively costly to produce.

5 There remains, therefore, a need for a push-fit connector having fewer individual parts which is simple and economical to manufacture, and is quick and requires no special skills to assemble.

10 The present invention addresses the aforementioned considerations.

 Other UK Patent Application Nos. 9502176.2, 9511416.1 and 9519811.5, in the name of the present
15 Assignees, also describe demountable pipe connectors. The entire disclosures of these applications are herein incorporated by reference for all purposes.

 For the avoidance of doubt, by connector it is not
20 meant that the connector is necessarily independent of the two or more items to be connected, rather, one or more of the items to be connected could comprise elements of the connector. For example, the tubular members could form part of a pipe or other fitting. In this way the
25 pipe or fittings could comprise elements of the connector.

The present invention provides a push-fit connector for a tubular member wherein a gripping means for the pipe or tube is mounted on the body of the connector.

5 According to a first aspect of the present invention, there is provided a connector between a first tubular member and a second tubular member, wherein the first tubular member has an open end adapted to receive the second tubular member in axial sliding engagement
10 therewith, and wherein there is further provided gripping means mounted on the wall of one of the said tubular members and adapted to bear upon the wall of the other tubular member in gripping engagement therewith.

15 The first and/or second tubular member may form part of other fittings such as valves, bends, reducers, tees, or other fittings or connectors such as those described in our copending International applications "Connectors" (Agents Ref: P31074PC), "Connectors" (Agents Ref:
20 P31350PC), "Connectors" (Agents Ref: P31364PC), filed herewith the entire disclosures of which are incorporated herein by reference for all purposes.

In a preferred embodiment the connector is adapted
25 so that the second tubular member is rotatable with respect to the other without, preferably, loss of sealing capability where provided. In this embodiment, the connector can be used with the pipe connector and

pivotable radiator described in copending International application entitled "Connectors" (Agents ref: P31350PC)

In a further embodiment there may be provided
5 annular sealing means adapted to form a seal between the first tubular member and the second tubular member, the arrangement being such that the gripping means and the sealing means are axially spaced apart and the gripping means is positioned between the sealing means and the
10 open end of the first tubular member.

Preferably the connector makes a push-fit connection with the second tubular member without requiring the screwing of a locking nut or the use of any other moving
15 parts.

If the second tubular member to be connected has a smooth surface, it can be advantageous to provide the gripping means with sharpened points or leading edges to
20 enable them to cut into the surface of the first tubular member to obtain a firm grip. Alternatively, the second tubular member can be provided with an annular groove or recess in which the gripping means are a snap fit. In the latter case the gripping means do not need to bear hard
25 against the surface of the tubular member, because interference with the groove walls should provide adequate pull-out resistance. Thus the first and second

tubular members may be rotatable one with respect to another.

Alternatively or in addition, one of the said
5 tubular members is provided with a plurality of radial
extending gripping means located circumferentially
thereof and the other of said tubular member may be
provided with an annular groove or recess in which the
gripping means are received in snap-fitting engagement
10 when the second tubular member is received in the first
tubular member.

The first tubular member is preferably adapted to
receive the second tubular member as a close sliding fit
15 within the open end, such that the first tubular member
surrounds the inserted end of the second tubular member.
The first and second tubular members are preferably made
from metal, and for example, they can be made from brass,
copper, or steel, and especially stainless steel.

20

The tubular members may be circular in cross-
section, or they may be square, rectangular or polygonal
as required. The tubular members can have any suitable
diameter dependent upon the application, but in general,
25 their diameters will be within the range of from about
8.0mm to 50.0mm. The wall thicknesses of the tubular
members will also depend upon the application, but they

will usually lie within the range of from about 0.5mm to 3.0mm.

In one embodiment, the connector is adapted such that one tubular member can be rotated with respect to the other tubular member. Preferably the adaptation comprises the provision of an annular groove on one tubular member and cooperating resilient members on the other tubular member.

10

In a preferred connector according to the invention, the gripping means is provided on the first tubular member and extends radially inwards, and the annular groove or recess is provided on the outer surface of the second tubular member.

In a preferred connector according to the invention, the gripping means is integral with its associated tubular member, which is preferably the first tubular member as aforesaid. Preferably the gripping means comprises an annular ring of resilient gripping members, and, for example the gripping means can comprise one or more rings of gripping tangs, preferably formed from a resilient material. The tangs are preferably angled with respect to the longitudinal axis of the associated tubular member and are preferably arranged on the internal wall of the first tubular member such that they point generally in the direction of insertion of the

second tubular member. In this position they can be relatively easily resiliently deformed when inserting the second tubular members into the first tubular member, and exert little resistance to the insertion, but provide a substantial resistance against axial-directed pull out forces when located in the groove or recess. Any suitable number of tangs may be provided, but usually between four and ten, for example about six, are sufficient.

10

Preferably the tangs, or other gripping members, are formed by making cuts or slots in the wall of the first or second tubular member and then pressing material of the wall of the tubular member either inwardly or outwardly as appropriate. The length and breadth of the tangs will depend on the application, but in general, the tangs are preferably from 1mm to 5mm in length, and preferably have a width of from 0.5mm to 3.5mm at their base. The tangs can, for example, be pointed or wedge-shaped, as desired.

20

The annular groove or recess can be provided in either the internal surface of the first tubular member or the external surface of the second tubular member, but preferably it is provided in the external surface of the second tubular member. The annular groove or recess preferably extends around the entire circumference of its associated tubular member. The depth of the annular

25

groove or recess should not be such as to weaken substantially the wall of its associated tubular member. In general, the annular groove or recess preferably has a depth of from 0.5mm to 2.0mm and a width of from 0.5mm
5 to 2.0mm.

The first and second tubular members can be elongate, for example, pipes, tubes, or conduits, or one or more of the tubular members can be a fitting, for
10 example, an in-line connector, a tee connector, a reducer, or a bend or may comprise part of a coupling or fitting such as those described in our copending International applications "Connectors" (Agents Ref: P31074PC), "Connectors" (Agents Ref: P31350PC),
15 "Connectors" (Agents Ref: P31364PC). These combined couplings are intended to lie within the scope of this application.

The annular sealing means is preferably formed from
20 a resilient material, and can comprise, for example, one or more 'O'rings, which may be made from natural or synthetic rubber, or any suitable polymeric material. The 'O'ring may be of any material selected so as to suit a particular application or location, for example, it may
25 compromise material resistant to chemical susceptibility or chemical attack. The 'O'ring or 'O'rings are preferably located in an annular groove formed in the wall of the first tubular member of the connector.

The connector may have one open end, for example, when joining a pipe to a fitting, or may have two or more open ends, for example an in-line coupling, or a tee fitting. A stop member, which can, for example, be an annular shoulder on the first tubular member, may be provided to limit the extent of sliding engagement of the first tubular member of the connector with the second tubular member.

10 Preferred embodiments of connectors according to the invention will now be described with reference to the accompanying Drawings in which:

Figure 1 shows a first connector according to the invention in sectional side elevation;

Figure 2 shows the connector of Figure 1 in end elevation; and

20 Figure 3 shows an exploded perspective view of a second connector according to the invention; and

Figure 4 shows part of the assembled connector of Figure 3 in sectional side elevation.

25

Figure 5 shows an isometric view of a disassembled connection in accordance with a further aspect of the invention.

Referring to Figures 1 and 2, the first connector, illustrated generally at 1, comprises a body member 2 having an open end 3. Within the open end, and adjacent to the lip thereof, there is positioned a plastic washer 4, which acts as a bearing for locating and guiding the pipe into the body member. Arranged around the body member are a series of teeth 5 which depend inwardly, and which have been pressed out of slots 6 cut in the wall of the body member 2. An 'O'ring sealing member 7 is located in an annular groove 8 formed in the wall of the body member 2. A shoulder 9, acting as a stop member, is provided in the internal surface of the body member 2. The connector has a profiled outer surface 10, to receive a second connecting part as described in our co-pending UK patent application no. GB9502176.2 entitled "Improvements in or relating to Demountable Connections" and filed on 3 February 1995 and our copending International application "Connectors" (Agents Ref: P31074PC) filed herewith.

20

In operation, a tubular member such as a pipe is simply pushed axially into the open end of the body member 2, displacing the teeth slightly outwards, and progressing until it meets the shoulder stop member 9. The pipe or tubular member is now sealed by the 'O'ring and prevented by the ring of resilient teeth 6 from axial pull out.

The connector of Figures 1 and 2 can be quickly fitted in a simple push-fit operation and requires no special tools or consumables. It is inexpensive to manufacture, can be of substantially unitary construction, and can be used to join metal and plastic pipes and fittings without any special adaptation.

Referring now to Figures 3 and 4, the second connector embodiment, illustrated generally at 20, comprises a body member 21 having an open end 22. Within the open end 22, and adjacent to the lip thereof, there is positioned a plastics washer 23, which acts as a bearing for locating and guiding the pipe into the body member. Arranged around the body member are a series of inwardly depending resilient wedge-shaped teeth 24, which have been pressed out of slots 25 cut in the wall of the body member 21. An 'O'ring sealing member 26 is located in an annular groove 27 formed by deforming the wall of the body member 21 outwardly. A shoulder 28, acting as a stop member, is provided in the internal surface of the body member 21.

The pipe 29 to be connected, is a sliding fit within the plastics washer 23 and the body member 21, and is provided with an annular groove or recess 30 in its outer surface. The groove 30 can be easily machined or cut with conventional equipment. The distance of the groove from the end 31 of the pipe is arranged such that when

the pipe is inserted in the connector 20, and the end 31 of the pipe abuts against the shoulder 28, the teeth 24 are a snap fit in the groove 30.

5 To make the connection, the pipe 29 is pushed axially into the open end 22 of the connector, displacing the resilient teeth 24 outwards, until the end 31 abuts against the shoulder 28. As the pipe is pushed home, a click will be heard as the teeth snap back into the
10 groove 30 indicating that the connection is completed.

The presence of the groove 30, as well as providing an audible indicator of the connection, thereby facilitating assembly, also increases the strength of the
15 connection. A further advantage of this embodiment is that, because the teeth do not need to cut into the surface of the pipe, the pipe can be rotated in the connector, even when the connector is under pressure.

20 Referring to Figure 5, the connection, indicated generally at 41, comprises a hollow tubular member 42 having a circumferentially arranged ring of tangs 43 which depend radially inwardly, and which have been pressed out of slots 44 cut in the wall of the first
25 tubular member 42. The tangs 43 depend inwardly at an angle to the axis of the first tubular member and point generally in the direction of insertion of the second tubular member 45.

The second tubular member 45 has an external diameter such that it is a close fit within the first tubular member 42 and has an annular groove 46 in its outer wall 47.

5

In use, when the second tubular member 45 is inserted axially within the first tubular member 42 the angled tangs 43 are displaced outwards, permitting the second tubular member 45 to slide into the first tubular
10 member 42. Once the groove 46 has passed the ring of tangs 43 the second tubular member 45 can be pulled back so that the tangs 43 slide along the wall 47 and snap back and lock into the groove 46.

15 The first and second tubular members are now firmly locked together and the second tubular member cannot be withdrawn.

It will be appreciated by those skilled in the art
20 that the connector of the invention may be used as a plug, air vent or the like.

Alternative embodiments of the invention can be envisaged by those skilled in the art from the
25 information contained herein. All such alternative embodiments are intended to lie within the scope of this application.

The reader's attention is directed to all papers and documents which are filed concurrently with or previous to this specification in connection with this application and which are open to public inspection with this 5 specification, and the contents of all such papers and documents are incorporated herein by reference.

All of the features disclosed in this specification (including any accompanying claims, abstract and 10 drawings), and/or all of the steps of any method or process so disclosed, may be combined in any combination, except combinations where at least some of such features and/or steps are mutually exclusive.

15 Each feature disclosed in this specification (including any accompanying claims, abstract and drawings), may be replaced by alternative features serving the same, equivalent or similar purpose, unless expressly stated otherwise. Thus, unless expressly 20 stated otherwise, each feature disclosed is one example only of a generic series of equivalent or similar features.

The invention is not restricted to the details of 25 the foregoing embodiment. This invention extends to any novel one, or any novel combination, of the features disclosed in this specification (including any accompanying claims, abstract and drawings), or to any

novel one, or any novel combination, of the steps of any method or process so disclosed.

CLAIMS

1. A connector between a first tubular member and a
second tubular member, wherein the first tubular
5 member has an open end adapted to receive the second
tubular member in axial sliding engagement
therewith, and wherein there is further provided

gripping means mounted on the wall of one of
10 the said tubular members adapted to bear upon the
wall of the other tubular member in gripping
engagement therewith.

2. A connector according to claim 1 further comprising:
15

annular sealing means adapted to form a seal
between the first tubular body member and the second
tubular body member, the arrangement being such that
the gripping means and the sealing means are axially
20 spaced apart and the gripping means is positioned
between the sealing means and the open end of the
first tubular member.

3. A connector according to claim 1 or 2 in which the
25 first and second tubular members are substantially
circular in cross-section.

4. A connector according to any preceding claim wherein the connector makes a push fit connection with the second tubular member without requiring the screwing of a locking nut or the use of any other moving parts.
- 5
5. A connector according to any preceding claim in which the second tubular member is rotatable relative to the first tubular members when the two are coupled together.
- 10
6. A connector according to claims 1-4 wherein the gripping means on one of the tubular members comprises sharpened points or leading edges or other means to enable them to cut into the surface of the other tubular member.
- 15
7. A connector according to any preceding claim wherein the second tubular member is provided with an annular groove or recess in which the gripping means are a snap fit.
- 20
8. A connector according to any of claim 2-7 wherein the annular sealing means comprises resilient material such as natural or synthetic rubber or any other suitable material.
- 25

9. A connector according to claims 2-8 wherein the annual sealing means comprises one or more 'O'rings.
10. A connector according to claim 9 wherein an 'O'ring
5 is located in an annular groove formed in the wall of the first tubular member of the connector.
11. A connector according to any preceding claim wherein one of the tubular members is provided with a
10 plurality of radially extending gripping means located circumferentially thereon and the other of said tubular members is provided with an annual groove or recess in which the gripping means are received in snap fitting engagement when the second
15 tubular member is received in the first tubular member.
12. A connector according to any preceding claim wherein the first tubular member has an open end and is
20 adapted to receive the second tubular member as a close sliding fit within the open end, such that the first tubular member surrounds the inserted end of the second tubular member.
- 25 13. A connector according to claim 12 wherein a stop member is provided on the first tubular member to limit the extent of sliding engagement of the first

tubular member of the connector with the second tubular member.

14. A connector according to any preceding claim wherein
5 the first and/or second tubular members comprise metal such as brass, copper, steel, stainless steel, or any other suitable metal, or any combination thereof.
- 10 15. A connector according to any of claims 1-14 wherein the first and/or second tubular members comprise plastic, plastics material or the like.
- 15 16. A connector according to any preceding claim wherein the first and/or second tubular member have diameters within the range of from about 8.0mm to 50.0mm.
17. A connector according to any preceding claim wherein
20 the first and/or second tubular member have all thicknesses which lie within the range of from about 0.5mm to about 3.5mm.
18. A connector according to any preceding claim wherein
25 the gripping means is provided on the first tubular member and extends radially inwards, and an annular groove or recess is provided on the outer surface of the second tubular member.

19. A connector according to any preceding claim wherein the gripping means is integral with its associated tubular member.
- 5 20. A connector according to any preceding claim wherein the gripping means comprises one or more resilient gripping members.
- 10 21. A connector according to any preceding claim wherein the gripping means comprises an annular ring of resilient gripping members.
- 15 22. A connector according to any preceding claim wherein the gripping means comprises one or more rings of gripping tangs.
- 20 23. A connector according to claim 22 wherein the tangs are angled with respect to the axis of the associated tubular member.
- 25 24. A connector according to claim 23 wherein the tangs are arranged on the internal wall of the first tubular member such that they point generally in the direction of insertion of the second tubular member.
- 25 25. A connector according to claim 22-24 wherein between about four and about ten tangs are provided.

26. A connector according to any preceding claim wherein the gripping means are formed by making cuts or slots in the wall of the first or second tubular member and then pressing material of the wall of the tubular member either inwardly or outwardly as appropriate.
27. A connector according to claims 22-26 wherein the tangs are from about 1mm to about 5mm in length.
28. A connector according to claims 22-27 wherein the tangs have a width of from about 0.5mm to about 3.5mm at their base.
29. A connector according to claims 22-28 wherein the tangs are pointed or wedge shaped.
30. A connector according to any preceding claim wherein an annular groove is provided in the external surface of the second tubular member.
31. A connector according to claims 7-30 wherein the annular groove extends around the entire circumference of its associated tubular member.
32. A connector according to claims 7-31 wherein the depth of the annular groove or recess is not such as

to weaken substantially the wall of its associated tubular member.

33. A connector according to claims 7-32 wherein the
5 annular groove has a depth of from about 0.5mm to about 2.0mm and/or a width of from about 0.5mm to about 2.0mm.
34. A connector according to any preceding claim wherein
10 the first and/or second tubular member comprises an in-line connector unit, a T-connector, a reducer, an elbow, a bend or other fitting.
35. A connector substantially as described herein with
15 reference to and/or as illustrated in the accompanying drawings.

1/2

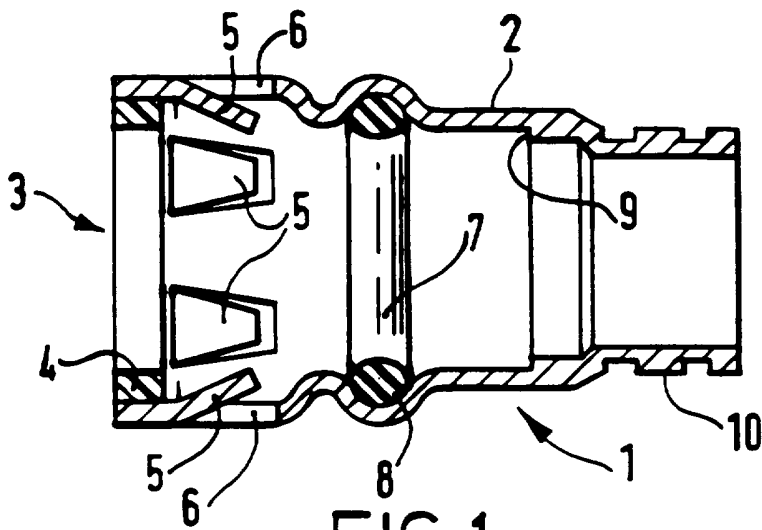

FIG. 1.

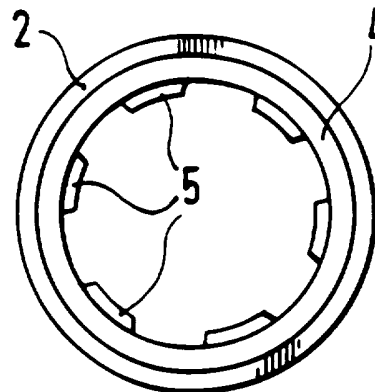

FIG. 2.

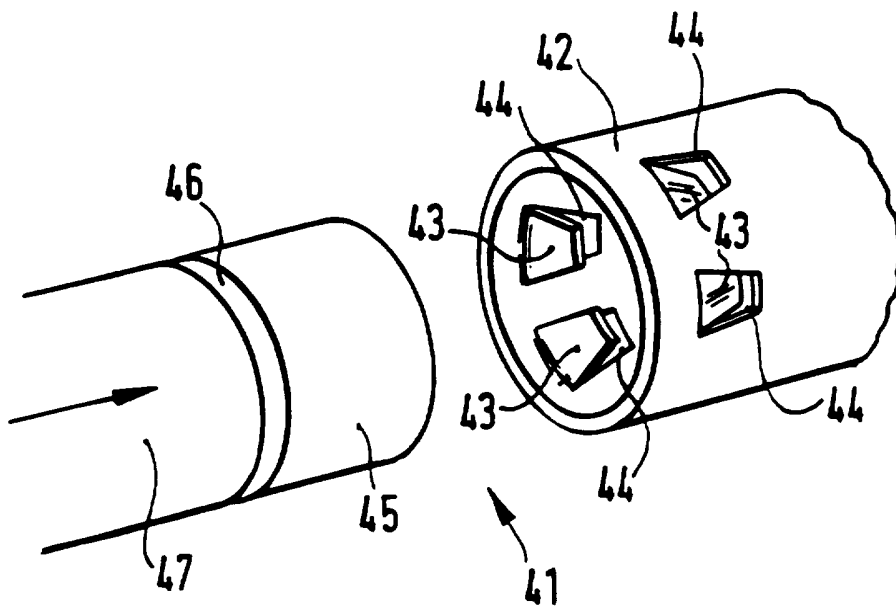

FIG. 5.

2/2

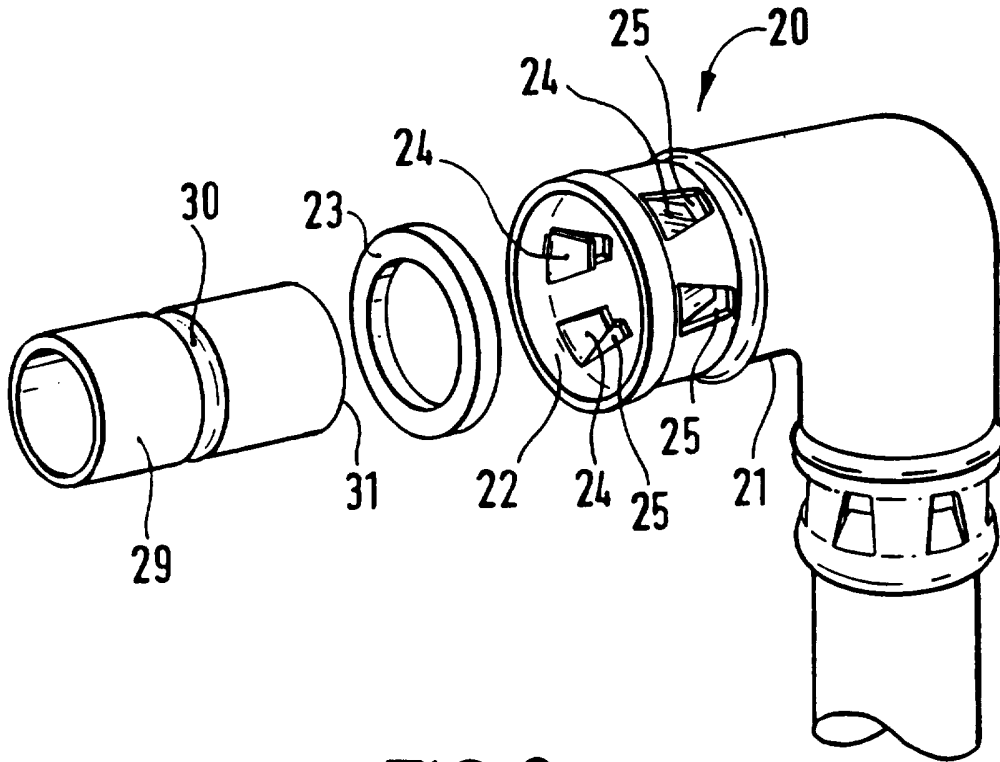

FIG. 3.

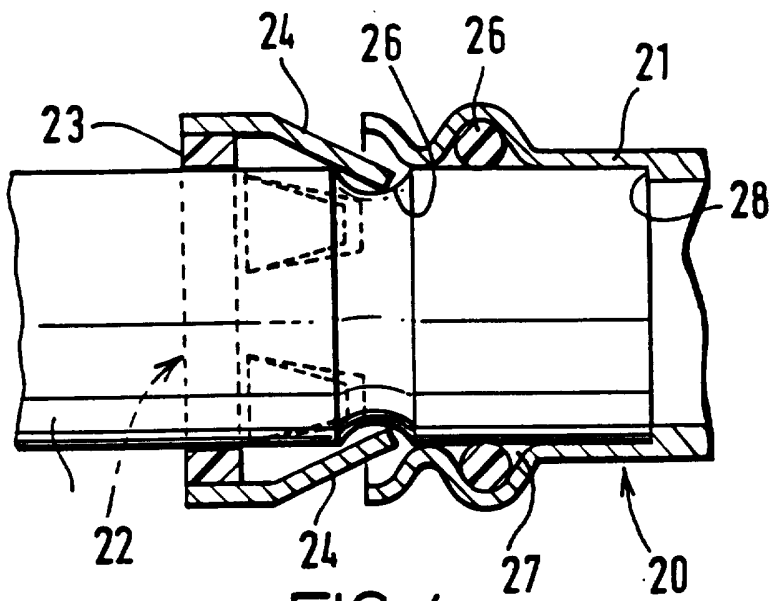

FIG. 4.

INTERNATIONAL SEARCH REPORT

Internat. Application No

PCT/EP 96/00450

A. CLASSIFICATION OF SUBJECT MATTER
 IPC 6 F16L37/08 F16L37/084

According to International Patent Classification (IPC) or to both national classification and IPC

B. FIELDS SEARCHED

Minimum documentation searched (classification system followed by classification symbols)
 IPC 6 F16L

Documentation searched other than minimum documentation to the extent that such documents are included in the fields searched

Electronic data base consulted during the international search (name of data base and, where practical, search terms used)

C. DOCUMENTS CONSIDERED TO BE RELEVANT

Category *	Citation of document, with indication, where appropriate, of the relevant passages	Relevant to claim No.
X	GB,A,2 014 681 (WAVIN B. V.) 30 August 1979 see claims 1-16; figures 1-3 ---	1,3-8, 11-13, 15-35
X	US,A,4 711 472 (SCHNELL) 8 December 1987 see abstract; figures 1-9 ---	1,3-8, 11-13, 15-35
X	EP,A,0 472 002 (JANSEN AG) 26 February 1992 see abstract; figures 1-8 ---	1-3
X	EP,A,0 519 244 (F. GROHE AG) 23 December 1992 see abstract; figures 1-5 ---	1,3,14
	-/--	

Further documents are listed in the continuation of box C.

Patent family members are listed in annex.

* Special categories of cited documents :

- *A* document defining the general state of the art which is not considered to be of particular relevance
- *E* earlier document but published on or after the international filing date
- *L* document which may throw doubts on priority claim(s) or which is cited to establish the publication date of another citation or other special reason (as specified)
- *O* document referring to an oral disclosure, use, exhibition or other means
- *P* document published prior to the international filing date but later than the priority date claimed

- *T* later document published after the international filing date or priority date and not in conflict with the application but cited to understand the principle or theory underlying the invention
- *X* document of particular relevance; the claimed invention cannot be considered novel or cannot be considered to involve an inventive step when the document is taken alone
- *Y* document of particular relevance; the claimed invention cannot be considered to involve an inventive step when the document is combined with one or more other such documents, such combination being obvious to a person skilled in the art.
- *&* document member of the same patent family

Date of the actual completion of the international search

22 May 1996

Date of mailing of the international search report

05.06.96

Name and mailing address of the ISA

European Patent Office, P.B. 5818 Patentlaan 2
 NL - 2280 HV Rijswijk
 Tel. (+ 31-70) 340-2040, Tx. 31 651 epo nl,
 Fax: (+ 31-70) 340-3016

Authorized officer

Angius, P

INTERNATIONAL SEARCH REPORT

Intern. Patent Application No
PCT/EP 96/00450

C.(Continuation) DOCUMENTS CONSIDERED TO BE RELEVANT		
Category *	Citation of document, with indication, where appropriate, of the relevant passages	Relevant to claim No.
X	US,A,3 672 708 (ZEMBERRY) 27 June 1972 see abstract; figures 1-5 ---	1,3,4
X	US,A,1 661 674 (M. OSBORN) 6 March 1928 see figures 1-3 -----	1,3,4

1

INTERNATIONAL SEARCH REPORT

Information on patent family members

International Application No

PCT/EP 96/00450

Patent document cited in search report	Publication date	Patent family member(s)	Publication date
GB-A-2014681	30-08-79	NL-A- 7801932	23-08-79
		BE-A- 874335	21-08-79
		DE-A- 2906317	23-08-79
		FR-A- 2417711	14-09-79

US-A-4711472	08-12-87	NONE	

EP-A-472002	26-02-92	CH-A- 682944	15-12-93
		AT-T- 124770	15-07-95
		DE-D- 59105914	10-08-95
		ES-T- 2073623	16-08-95

EP-A-519244	23-12-92	DE-A- 4119642	17-12-92
		AT-T- 119261	15-03-95
		DE-D- 59201512	06-04-95
		ES-T- 2072049	01-07-95
		JP-A- 5180381	20-07-93
		US-A- 5259650	09-11-93

US-A-3672708	27-06-72	NONE	

US-A-1661674	06-03-28	NONE	
