



- (51) International Patent Classification:  
G06Q 30/02 (2012.01)
- (21) International Application Number:  
PCT/US2011/065995
- (22) International Filing Date:  
20 December 2011 (20.12.2011)
- (25) Filing Language: English
- (26) Publication Language: English
- (30) Priority Data:  
12/973,680 20 December 2010 (20.12.2010) US
- (71) Applicant (for all designated States except US): **ADOBE SYSTEMS INCORPORATED** [US/US]; 345 Park Avenue, San Jose, CA 95110-2704 (US).
- (72) Inventor; and
- (75) Inventor/Applicant (for US only): **KAMATH, Anil** [US/US]; 919 Clara Drive, Palo Alto, CA 94303 (US).
- (74) Agents: **KOWERT, Robert, C.** et al.; Meyertons, Hood, Kivlin, Kowert & Goetzel, P.C., P.O. Box 398, Austin, TX 78767-0398 (US).

(81) Designated States (unless otherwise indicated, for every kind of national protection available): AE, AG, AL, AM, AO, AT, AU, AZ, BA, BB, BG, BH, BR, BW, BY, BZ, CA, CH, CL, CN, CO, CR, CU, CZ, DE, DK, DM, DO, DZ, EC, EE, EG, ES, FI, GB, GD, GE, GH, GM, GT, HN, HR, HU, ID, IL, IN, IS, JP, KE, KG, KM, KN, KP, KR, KZ, LA, LC, LK, LR, LS, LT, LU, LY, MA, MD, ME, MG, MK, MN, MW, MX, MY, MZ, NA, NG, NI, NO, NZ, OM, PE, PG, PH, PL, PT, QA, RO, RS, RU, RW, SC, SD, SE, SG, SK, SL, SM, ST, SV, SY, TH, TJ, TM, TN, TR, TT, TZ, UA, UG, US, UZ, VC, VN, ZA, ZM, ZW.

(84) Designated States (unless otherwise indicated, for every kind of regional protection available): ARIPO (BW, GH, GM, KE, LR, LS, MW, MZ, NA, RW, SD, SL, SZ, TZ, UG, ZM, ZW), Eurasian (AM, AZ, BY, KG, KZ, MD, RU, TJ, TM), European (AL, AT, BE, BG, CH, CY, CZ, DE, DK, EE, ES, FI, FR, GB, GR, HR, HU, IE, IS, IT, LT, LU, LV, MC, MK, MT, NL, NO, PL, PT, RO, RS, SE, SI, SK, SM, TR), OAPI (BF, BJ, CF, CG, CI, CM, GA, GN, GQ, GW, ML, MR, NE, SN, TD, TG).

**Published:**

— without international search report and to be republished upon receipt of that report (Rule 48.2(g))

(54) Title: METHOD AND APPARATUS FOR ADVERTISING BIDDING

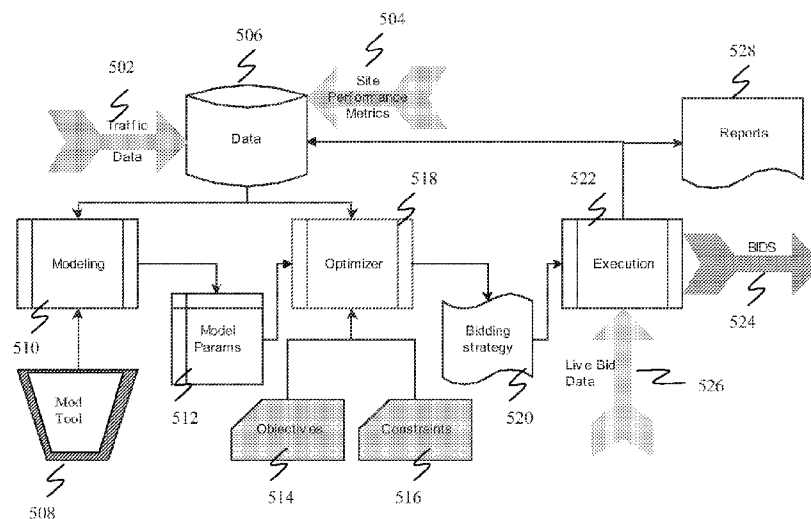

Figure 1

(57) Abstract: Methods, articles, and systems for determining a bidding strategy for on- query answer set or contextual advertise- ment positions for marketing options is described herein.

WO 2012/088020 A2

# **METHOD AND APPARATUS FOR ADVERTISING BIDDING**

## **Technical Field**

[0001] The present invention relates generally to the fields of data processing and electronic advertising. More specifically, the present invention relates to on-line query answer set or contextual advertisement position bidding. On-line query answer set may also be referred to as on-line search result answer/return set.

## **Background of the Invention**

[0002] In conventional systems, marketing purchases (also referred to as advertisement buys) are typically optimized individually and performance measurement and purchase decisions are made separately for each marketing option. An organization can have a large number of available marketing options (advertisement buys) that are priced differently, and deliver different results. For example, search engines have paid listings, where the cost per click to bring a visitor from the search engine is different based on the keyword that the visitor on the search engine searched for and the position at which the advertisement is displayed. Similarly, most web sites have different charges for different contextual advertisement positions or for different audiences that are shown the advertisements.

[0003] Thus, an approach that enables a decision maker to make marketing purchase (advertisement buy) decisions, by allocating dollars across a portfolio of marketing

options (advertisement buys) so as to meet specific composite goals and performance criteria, is desirable.

### **Brief Description of the Drawings**

[0004] The present invention will be described by way of exemplary embodiments, but not limitations, illustrated in the accompanying drawings in which like references denote similar elements, and in which:

[0005] **Fig. 1** is an overview illustrating the present invention according to one embodiment.

[0006] **Fig. 2** is a example visualization of predicted revenue according to different budget allocations.

[0007] **Fig. 3** is an example visualization of predicted conversions according to different budget allocations.

[0008] **Fig. 4** is a block diagram illustrating a computing device suitable for use to practice the present invention.

### **Detailed Description of Illustrative Embodiments**

[0009] Embodiments of the present invention includes a system and its components that enable a decision maker to make marketing purchase (advertisement buy) decisions, by allocating dollars across a portfolio of marketing options (advertisement buys) so as to meet specific composite goals and performance criteria.

[0010] In the description to follow, embodiments of the present invention will be described using terminologies commonly employed by those skilled in the art to present their work, including but not limited to terms like web site, web pages, clicks,

on-line query, search engine, answer set, modeling, regression analysis, optimization, objective functions, constraints, and so forth. These terms are to be accorded the common meaning as understood by those of the ordinary skill in the arts of information technology and applied mathematics.

**[0011] Process Flow**

**[0012]** In one embodiment, the process of the present invention may comprise the following operations:

**[0013]** - Model

**[0014]** - Optimize

**[0015]** - Execute

**[0016]** Each aspect will be described in turn, referencing Fig. 1.

**[0017] Model**

**[0018]** In one embodiment, the system may include modeling **510** for the different marketing options (advertisement buys) available to an organization. The modeling parameters **512** may include, but are not limited to a number of visitors, a cost of bringing the visitors, number of unique visitors, transactions, revenues generated by the visitors, and so forth. In various embodiments, the modeling parameters may also include information about visitors who may view the marketing options, such as, for example, demographic information, interests and likes, or behavioral information. In various embodiments, demographic information may include information such as age, gender, geographic location, employment, education, and/or membership in one or more groups. Thus, in various embodiments, bidding strategies which are based on models including demographic information may direct bids which maximize impressions by visitors that satisfy particular a demographic makeup. For example, a

bidding strategy may seek to maximize impressions by residents of Los Angeles, or students at UCLA, or males between 18 and 34 years of age. In other embodiments, bidding strategies which are based on models including demographic information may direct bids which recognize value provided by showing advertisements to different demographic groups. For example, a bidding strategy may seek to maximize impressions by males between 18 and 34 years of age for a particular video game product, because the model incorporates knowledge that this group of viewers are more likely to cause a conversion than other groups. In other embodiments, the modeling parameters may include unique identifying information about one or more visitors. The models may comprise be statistical models based on measurable empirical data **506**.

**[0019]** In one embodiment, the models are constructed by gathering empirical data **506** by purchasing the various marketing options for a limited period of time, and measuring the resulting clicks, visitors, transaction, revenues, and so forth **502** and **504**. In various embodiments, the information may be tracked on a per-visitor basis that it may be combined with information identifying visitors or visitor demographics. Further, for the embodiment, a least mean squared fit over the empirical data may be performed to determine the expected values of the model parameters **512**, using a modeling software **508** like AMPL (a modeling language for linear programming) or Splus (software for statistical modeling). For example, for the paid listings on search engines like Overture and Google, empirical data for different keywords at different positions may first be obtained, and then the ratio of clicks at position  $i$  to clicks at position  $i+1$  through a least mean squared regression may be determined. Using this model, the traffic that can be generated at different positions and/or for different keywords may be inferred.

[0020] In various embodiments, models may be specified to determine model objectives for multiple sites or auctions. Thus, in some embodiments, a model may be used to determine different bidding strategies for different websites. In various embodiments, a model may comprise empirical data for multiple web sites in addition to data for particular positions within websites. Thus, a bidding strategy produced by solving an objective function for a model may produce different bid amounts for different web sites or auctions depending on those web sites' or auctions' ability to fulfill objectives, such as revenue, conversion rates, and others, as described herein. The bidding strategy may therefore result in bids for marketing options which are placed in different positions on different web sites. In various embodiments, models may be used to determine different bidding strategies for different audiences (e.g., viewers of advertisements may be differentiated based on their demographic information, interests, likes, and/or past behaviors). In some embodiments audience models may be combined with models for websites to determine different bidding strategies for different audiences seeing the ads at different websites.

[0021] In various embodiments, the models may include a click model that may forecast the number of clicks for the various on-line query answer set or contextual advertisement positions available from various search engines and/or web sites. Embodiments may include a cost model that may forecast costs of ad impressions or clicks for various audiences or websites and models. In various embodiments, the cost model may predict how different bid levels may result in different levels of spending on different audiences or websites due to different numbers of impressions and clicks on those audiences or websites. In other embodiments, models may include a revenue model that forecasts revenue based at least in part on click

conversion. In various embodiments, models may include a model which forecasts conversions from clicks to purchases.

**[0022] Optimize**

**[0023]** In one embodiment, once the models for the different variables that are within the scope to improve or control, the models **510** may be specified to perform an optimization of measurable objectives **514** that have been modeled. In various embodiments, the measurable objectives may include number of unique visitors, number of transactions, revenues, profits, conversions, etc. In some embodiments, objectives may be generated by using some combination of marketing options. The specification may be effectuated through a variety of input techniques. In various embodiments, a graphical user interface is provided to specify the models **510**, or more specifically, the model parameters and their relationships **512**. The optimization of these objectives **514** may be subject to constraints **516** that involve controlling some other measurable modeled variables such as the money spent on marketing, certain minimum lead generation requirements, etc.

**[0024]** In various embodiments a graphical user interface may be configured to allow changes to model parameters, followed by re-optimization. Thus, a user of the graphical user interface may see be able to see changes to a bidding strategy take place dynamically as the user changes one or more model parameters. In various embodiments, these changes may be performed by repeating optimization of the model with the changed parameters.

**[0025]** The optimization problem may be modeled as a mathematical programming problem. In some embodiments, if all the models involved are linear models the optimization problem is a linear programming problem, which can be solved using a standard linear programming/optimization solver like CPLEX or MINOS **518**. In

other embodiments, the optimization problem may be formulated as a non-linear problem, and solved employing any one of a number of non-linear optimization techniques. The solution to the optimization problem can be a set of marketing purchase decisions or a market budget allocation strategy (also referred to as a bidding strategy) **520** that needs to be executed by the organization.

**[0026]** In various embodiments, the optimization may be performed with reference to a specific visitor or instance of a web site or auction. For example, in various embodiments, an optimization may be performed in response to a visitor requesting to view a website. In various embodiments, the optimization may then be performed in real time to determine a bidding strategy with respect to the particular visitor performing the request and/or the particular web site being requested.

**[0027] Objective functions**

**[0028]** In various embodiments, the measurable goals (or objectives) **512** that may be used may be one or more of the following:

**[0029]** - maximizing traffic (also referred to as clicks) for the marketing options for a given budget;

**[0030]** - minimizing cost to get certain traffic for the marketing options;

**[0031]** - minimizing customer or visitor acquisition cost for the products or services of the marketing options;

**[0032]** - maximizing revenues for the products or services of the marketing options;

**[0033]** - maximizing profits for the products or services after as a net of cost of the marketing options;

**[0034]** maximizing profit margins for the products or services as a net of cost of the marketing options;

**[0035]** - minimizing marketing expenses for the marketing options;



[0036] - maximizing increases of customer sign-ups or registrations for products or services of the marketing options;

[0037] - minimizing cost measured on a per-conversion or per-purchase basis;

[0038] - maximizing number of impressions that may be obtained by visitors which satisfy a given demographic makeup; and

[0039] - maximizing engagement with an advertisement or brand (e.g., getting “likes” on Facebook, “tweets” about the brand on twitter, views of the video ads etc.).

[0040] In alternate embodiments, other objective functions **512** may be employed in addition to or in lieu of the earlier enumerated objective functions.

#### [0041] Constraints

[0042] In various embodiments, constraints may be set and differing levels of granularity, from cost-per-conversion numbers, to budgets for entire advertising channels. In various embodiments, the measurable constraints on the marketing decisions may be one or more of the following enumerated constraints:

[0043] - traffic to certain URLs (Uniform Resource Locators) should exceed certain amount during a certain period;

[0044] - certain keywords should be at specified positions;

[0045] - costs per click should not exceed a certain amount;

[0046] - costs per conversion should not exceed a certain amount;

[0047] - user acquisition costs should be below certain amount;

[0048] - marketing expenses for the marketing options should be below a budget limit;

[0049] - expenses for other marketing options or advertising channels other than those which are being optimized for is set at a particular limit;

[0050] - revenues generated for products or services of the marketing options should be below a limit; and

[0051] - profit margins net of marketing costs should be above a certain limit.

[0052] In alternative embodiments, measurable constraints may comprise other constraints in addition to or in lieu of the earlier enumerated constraints.

**[0053] Execute**

[0054] In various embodiments, the marketing strategy or spending decisions (bidding strategy) 520 may be implemented 522 to make bids 524. The implementation may also be monitored and adjusted 522 in the context of the changing marketing options available 526 and the changing objectives and requirements of the organization 514 and 516 (re-performing the earlier described optimization operation). For example, based on the availability of cheaper marketing options 526, a decision may be made to stop an advertising campaign at a specific site or for paid listings on search engines, the bid or the maximum cost per click that an organization presumably is willing to pay for a paid listing for a keyword, may be changed, based on the gross margins generated from transactions made by visitors clicking on that keyword listing. In various embodiments, the results of the implementations are captured as reports 528, and the data contained in the reports 528 are fed back to add to or update the empirical data employed to build the models 510. The models 510 may be updated, and inputs and/or constraints changed, and the optimization process 518 may be re-performed to yield one or more new bidding strategies 520.

[0055] In various embodiments, bidding strategies and/or objective values obtained by finding solutions to objective functions may be output to a user in the form of a visualization. In various embodiments, multiple solutions to the objective problem

may be generated based on changing inputs or changing constraints. For example, **Figure 2** illustrates an example visualization of predicted revenue based on various budget amounts. The budget/revenue relationship visualization **210** may show an advertiser what revenue is predicted for the advertiser based on various advertising budget amounts. Thus, in the example illustrated, predicted revenue increases as advertising budgets increase. However, the relationship may not be linear, as illustrated, for example, in **Figure 2**. In alternative visualizations, different bidding strategies may be displayed based on changes to inputs or constraints.

[0056] In another Example, **Figure 3** illustrates an example visualization of predicted conversions based on various budget amounts. The cost to conversion relationship, represented by line **310** shows a relationship that is non-linear, as differentiated from the linear relationship **320**, which shows a constant cost-per-conversion relation, also known as “CPA”. In between the two illustrated relationships are various points predicting pairs of conversion rates and cost, such as point **305**. As the visualization of **Figure 3** illustrates, in various embodiments, a user may be shown how changes made using the bidding strategy generation techniques described herein may result in different benefits to an advertiser. For example, starting from a point **330** on the constant cost-per-conversion line **320**, a bidding strategy may be generated that minimizes an advertiser’s budget while maintaining the same number of conversions. This would result in the a conversion level that is represented by point **340**. Conversely, a bidding strategy may be generated that, for a constant budget, increases conversions, such as at point **350**. In another example, a bidding strategy may be generated that, increases conversions as much as possible while maintaining a constant CPA, such as at point **360**. In alternative visualizations, different bidding strategies may be displayed based on changes to inputs or constraints.

**[0057] Making a market in marketing**

**[0058]** The present invention may also be employed to create a market in marketing options, where sites (“the sellers”), with marketable visitors can ask varying rates for different advertising options and the organizations that need those visitors (“the buyers”) bid different prices for the different options depending on the value they associate with the visitor. An entity can then play the role of the market maker in such a market by matching the buyers with the sellers for a commission.

**[0059]** The market maker can match buyers and sellers by simply presenting the various options to the buyers and sellers and let them make their decisions individually. The market also supports the role of a broker, who can also take the objectives of one or multiple sellers to optimize their marketing objectives for a commission. For paid listings on search engines, the price for a click from a certain position on the search results page for a certain keyword depends on the price that different “buyers” are willing to bid for that position. This can sometimes create bidding wars between buyers that result in the buyers collectively paying a high price for their clicks. A broker, by pulling together the different competing buyer entities, can collectively optimize the different objectives and requirements thereby providing a lower cost solution to the buyers that meet the buyers’ objectives.

**[0060] Exemplary System**

**[0061]** **Figure 3** illustrates an example computing system/device suitable for use to practice the present invention, in accordance with one embodiment. As shown, computing system/device **600** includes one or more processors **602**, and system memory **604**. Additionally, computing system/device **600** includes mass storage devices **606** (such as diskette, hard drive, CDROM and so forth), input/output devices

**608** (such as keyboard, cursor control and so forth) and communication interfaces **610** (such as network interface cards, modems and so forth). The elements are coupled to each other via system bus **612**, which represents one or more buses. In the case of multiple buses, they are bridged by one or more bus bridges (not shown).

**[0062]** Each of these elements performs its conventional functions known in the art. In particular, system memory **604** and mass storage **606** may be employed to store a working copy and a permanent copy of the programming instructions implementing one or more aspects of the earlier described teachings to practice the present invention, i.e. the modeling, the optimization, the bidding and so forth. The programming instructions may be implemented in assembler instructions supported by processor(s) **602** or high level languages, such as C, that can be compiled into such instructions. The communication to place the bids may be implemented in any one of a number of proprietary or open communication/transaction protocol, including but are not limited to HTTP and TCP/IP.

**[0063]** The permanent copy of the programming instructions may be placed into permanent storage **606** in the factory, or in the field, through e.g. a distribution medium (not shown) or through communication interface **610** (from a distribution server (not shown)).

**[0064]** Except for the modeling, optimization, and bidding logic, the constitution of these elements **602-612** are known, and accordingly will not be further described.

**[0065] Epilog**

**[0066]** Although specific embodiments have been illustrated and described herein for purposes of description of the preferred embodiment, it will be appreciated by those of ordinary skill in the art that a wide variety of alternate and/or equivalent implementations may be substituted for the specific embodiment shown and described

without departing from the scope of the present invention. Those with skill in the art will readily appreciate that the present invention may be implemented in a very wide variety of embodiments. This application is intended to cover any adaptations or variations of the embodiments discussed herein. Therefore, it is manifestly intended that this invention be limited only by the claims and the equivalents thereof.

## Claims

What is claimed is:

1. A method for determining a bidding strategy to be used when buying advertising by placing one or more bids for a plurality of marketing options, the method comprising:
  - facilitating, by a computing device, prior to placement of one or more bids, specification of one or more models that model one or more performance parameters for the plurality of marketing options;
  - determining, by the computing device, prior to placing the one or more bids, a bidding strategy wherein:
    - the bidding strategy directs allocation of monetary resources to place the one or more bids among the plurality of marketing options; and
    - determining comprises solving, by the computing device, an objective function configured to optimize at least one performance parameter for the plurality of marketing options using the specified one or more models; and
    - after determining the bidding strategy, outputting, by the computing device, the determined bidding strategy for use in placing the one or more bids among the marketing options.
2. The method of claim 1, wherein facilitating specification of one or more models comprises, facilitating, by the computing device, specification of a model configured to model the one or more performance metrics based at least in part on information about visitors which may view the marketing options.
3. The method of claim 2, wherein the model is configured to model the one or more performance metrics based at least in part on demographic information about visitors which may view the marketing options.
4. The method of claim 2, wherein the model is configured to model the one or more performance metrics based at least in part on an identity of a visitor which may view the marketing options.

5. The method of claim 4, wherein the determining the bidding strategy comprises determining, by the computing device, the bidding strategy with reference to a web page and a visitor in response to the visitor requesting to view the web page.
6. The method of claim 1, wherein facilitating specification of one or more models comprises facilitating, by the computing device, specification of a model configured to model the one or more performance metrics based at least in part on a plurality of advertising positions occupied by the marketing options.
7. The method of claim 6, wherein:
  - facilitating specification of the model comprises facilitating, by the computing device, specification of a model configured to model the one or more performance metrics based at least in part on a plurality of advertising positions on multiple web sites; and
  - the output bidding strategy directs bids to marketing options which are placed at different advertising positions on different web sites.
8. The method of claim 6, wherein the plurality of advertising positions occupied by the marketing options are modeled as responsive to monetary resources allocated to the one or more bids placed among the marketing options.
9. The method of claim 6, wherein the plurality of advertising positions are positions occupied by the marketing options in a selected one of on-line query answer sets and contextual advertisements.
10. The method of claim 1, wherein outputting the determined bidding strategy comprises generating, by the computing device, one or more visualizations describing the bidding strategy.
11. The method of claim 10, further comprising receiving, by the computing device, indications of one or more constraints; and
  - wherein:
    - solving an objective function comprises solving, by the computing device, the objective function subject to the one or more constraints; and
    - generating one or more visualizations comprises generating, by the computing device, visualizations which show a first objective value



determined through a first solution to the objective function solved subject to a first constraint and a second objective value determined through a second solution solved subject to a second constraint.

12. The method of claim 11, wherein generating one or more visualizations comprises generating one or more curves showing how objective values change as constraints change.
13. The method of claim 11, wherein determining the bidding strategy subject to the one or more constraints comprises determining the bidding strategy subject to a constraint requiring a cost limit for a cost-per-conversion measure.
14. The method of claim 11, wherein determining the bidding strategy subject to the one or more constraints comprises determining the bidding strategy subject to a constraint requiring a cost limit for expenditures on an advertising channel.
15. An article of manufacture comprising a tangible, non-transitory computer-readable medium having instructions stored thereon that, responsive to execution by a computing device, cause the computing device to perform operations comprising:
  - facilitating, prior to placement of one or more bids for buying advertising, specification of one or more models that model one or more performance parameters for a plurality of marketing options, wherein facilitating specification of one or more models comprises facilitating specification of a model configured to model the one or more performance metrics based at least in part on demographic or identify information about visitors which may view the marketing options;
  - determining, prior to placing the one or more bids, a bidding strategy wherein the bidding strategy directs allocation of monetary resources to place the one or more bids among the plurality of marketing options; and
  - after determining the bidding strategy, outputting the determined bidding strategy for use in placing the one or more bids among the marketing options.
16. The article of claim 15, wherein
  - facilitating specification of one or more models comprises facilitating specification of a model configured to model the one or more performance metrics based at least in part on a plurality of advertising positions on multiple web sites; and
  - the output bidding strategy directs bids to marketing options which are placed

at different advertising positions on different web sites.

17. The article of claim 15, wherein the bidding strategy directs allocation of monetary resources to place the one or more bids among the plurality of marketing options; and wherein determining comprises solving an objective function configured to optimize at least one performance parameter for the plurality of marketing options using the specified one or more models.

18. The article of claim 15, wherein outputting the determined bidding strategy comprises generating one or more visualizations describing the bidding strategy.

19. The article of claim 17, wherein the operations further comprise receiving indications of one or more constraints; and

wherein:

solving an objective function comprises solving the objective function subject to the one or more constraints; and

generating one or more visualizations comprises generating visualizations which show a first objective value determined through a first solution to the objective function solved subject to a first constraint and a second objective value determined through a second solution solved subject to a second constraint.

20. An apparatus, comprising:

one or more computer processors;

memory, coupled to the one or more computer processors, containing programming instructions, which, when executed on the one or more computer processors, cause the apparatus to:

facilitate, prior to placement of one or more bids for buying advertising, specification of one or more models that model one or more performance parameters for a plurality of marketing options, wherein facilitating specification of one or more models comprises facilitating specification of a model configured to model the one or more performance metrics based at least in part on a plurality of advertising positions on multiple web sites;

determine, prior to placing the one or more bids, a bidding strategy

wherein the bidding strategy directs allocation of monetary resources to place the one or more bids among the plurality of marketing options; and

after determining the bidding strategy, output the determined bidding strategy for use in placing the one or more bids among the marketing options, wherein the output bidding strategy directs bids to marketing options which are placed at different advertising positions on different web sites.

21. The apparatus of claim 20, wherein facilitate specification of one or more models comprises facilitate specification of a model configured to model the one or more performance metrics based at least in part on demographic or identify information about visitors which may view the marketing options.
22. The apparatus of claim 20, wherein determine comprises generate a solution for an objective function configured to optimize at least one performance parameter for the plurality of marketing options using the specified one or more models.
23. The apparatus of claim 20, wherein output the determined bidding strategy comprises generate one or more visualizations describing the bidding strategy.
24. The apparatus of claim 23, wherein the apparatus is further caused to receive indications of one or more constraints; and  
wherein:
  - determine comprises generate one or more solutions to an objective function configured to optimize at least one performance parameter for the plurality of marketing options using the specified one or more models, subject to the one or more constraints; and
  - generate one or more visualizations comprises generating visualizations which show a first objective value determined through a first solution to the objective function solved subject to a first constraint and a second objective value determined through a second solution solved subject to a second constraint.
25. The method of claim 6, wherein:
  - facilitating specification of the model comprises facilitating, by the computing device, specification of a model configured to model the one or more performance metrics based at least in part on a plurality of audiences on multiple web sites; and

the output bidding strategy directs bids to marketing options which result in different numbers of impressions of the advertisement to different numbers of audiences on various websites.

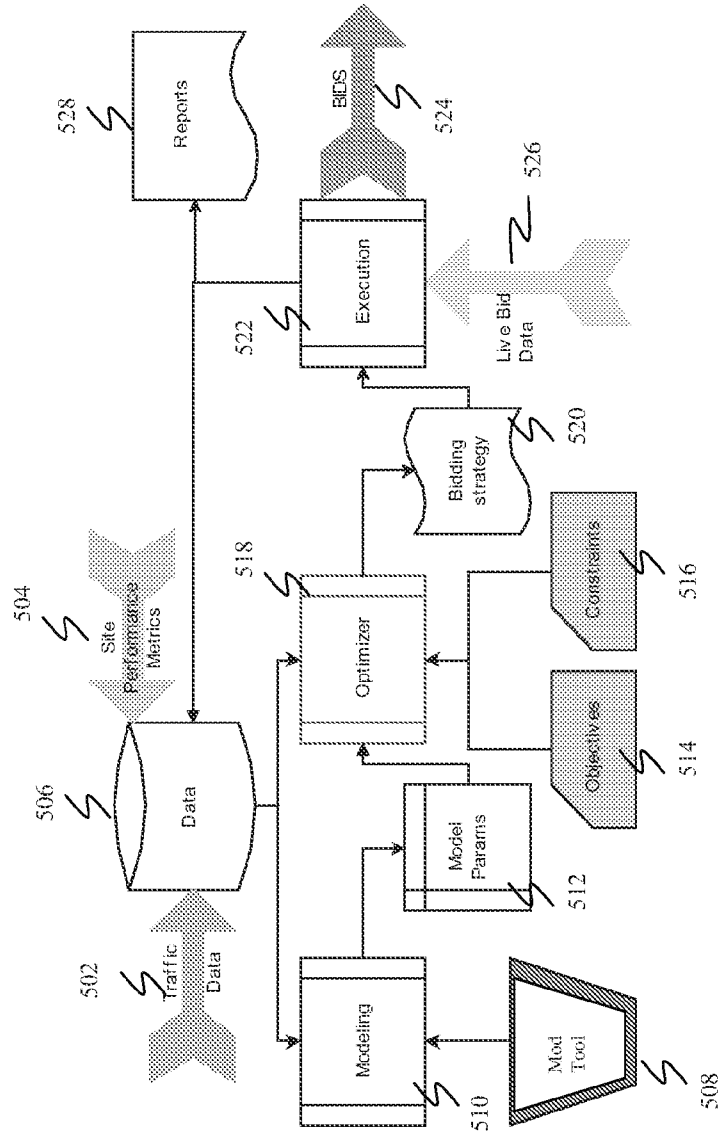
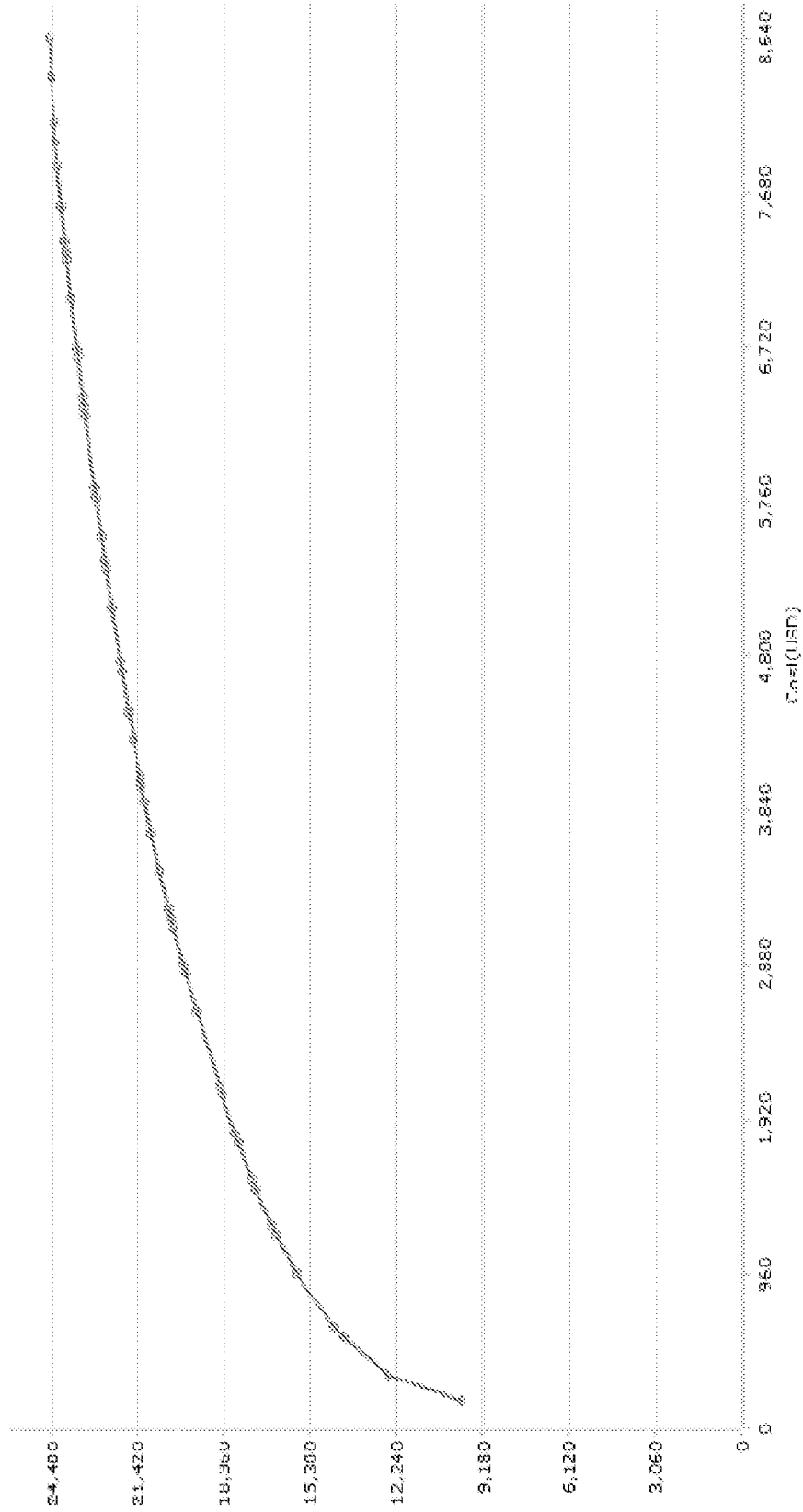

Figure 1

Fig. 2



Budget/Revenue Relationship  
Visualization 210

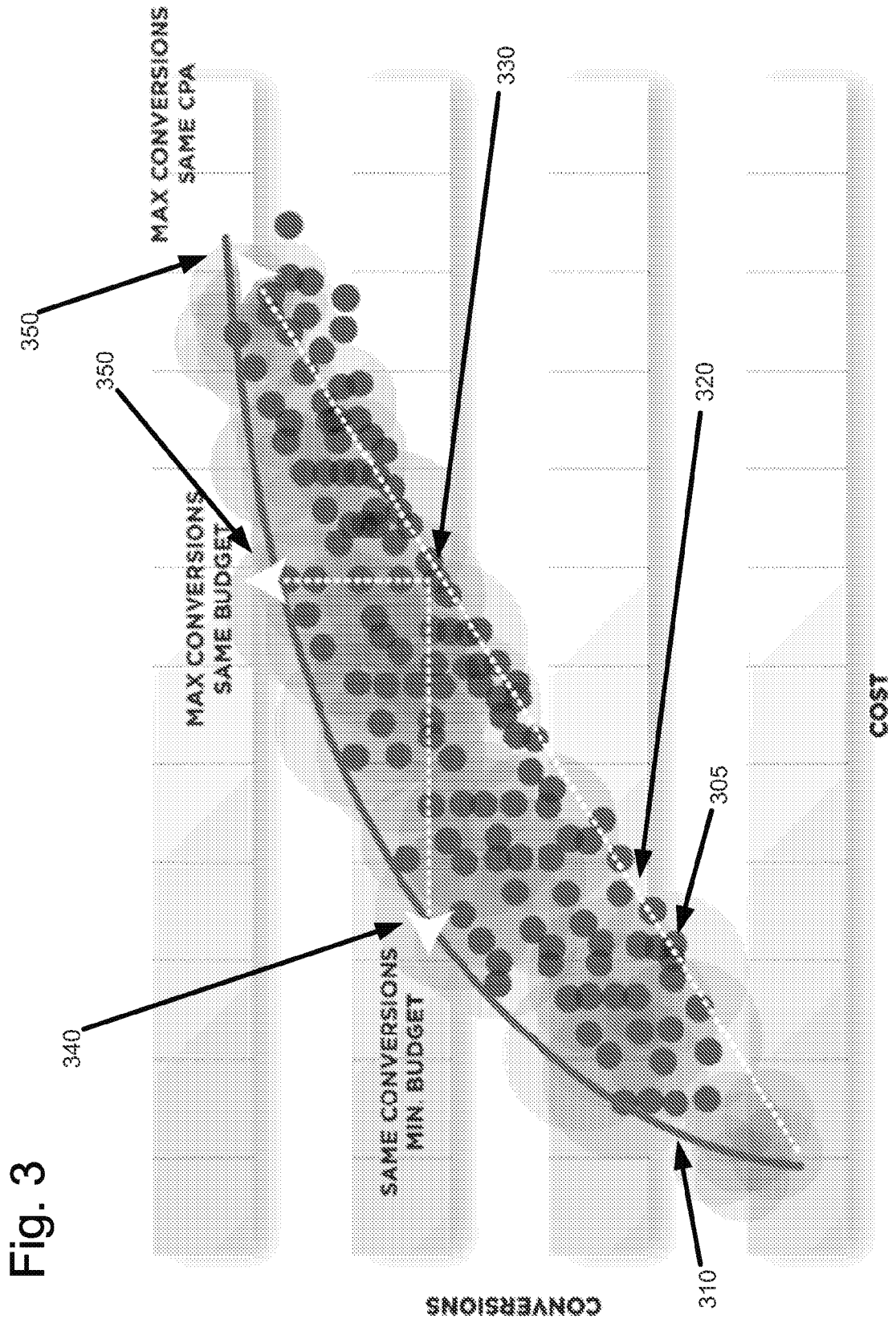

Fig. 3

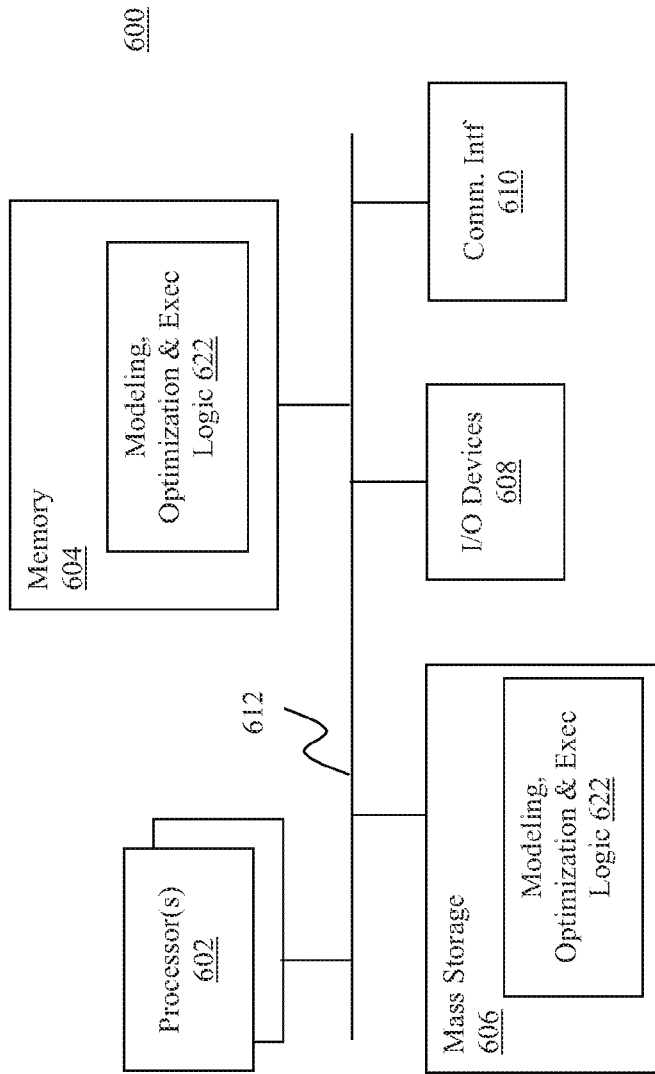

Figure 4