



Europäisches Patentamt
European Patent Office
Office européen des brevets



(11) **EP 0 760 882 B1**

(12) **EUROPEAN PATENT SPECIFICATION**

(45) Date of publication and mention
of the grant of the patent:

10.04.2002 Bulletin 2002/15

(21) Application number: **95923652.2**

(22) Date of filing: **27.06.1995**

(51) Int Cl.7: **E01C 19/10**

(86) International application number:
PCT/SE95/00785

(87) International publication number:
WO 96/00324 (04.01.1996 Gazette 1996/02)

(54) **METHOD AND DEVICE FOR COLD MIXING OF ROAD SURFACING MATERIAL**

VERFAHREN UND VORRICHTUNG ZUM KALTMISCHEN VON FAHRBAHNBELAG

PROCEDE ET DISPOSITIF POUR LE MELANGE A FROID DE MATERIAU DE REVETEMENT
ROUTIER

(84) Designated Contracting States:
AT BE CH DE DK ES FR GB GR IE IT LI NL PT

(30) Priority: **27.06.1994 SE 9402263**

(43) Date of publication of application:
12.03.1997 Bulletin 1997/11

(73) Proprietor: **LEIF PERSSON PLANT I LOMMA AB**
234 34 Lomma (SE)

(72) Inventor: **Persson, Leif Lennart**
264 37 Klippan (SE)

(74) Representative: **Berglund, Gustav Arthur et al**
AWAPATENT AB,
Box 5117
200 71 Malmö (SE)

(56) References cited:
WO-A-83/00700 **WO-A-87/03317**
US-A- 4 974 993

EP 0 760 882 B1

Note: Within nine months from the publication of the mention of the grant of the European patent, any person may give notice to the European Patent Office of opposition to the European patent granted. Notice of opposition shall be filed in a written reasoned statement. It shall not be deemed to have been filed until the opposition fee has been paid. (Art. 99(1) European Patent Convention).

Description

[0001] The present invention relates to a method and a device for cold mixing of road surfacing material.

[0002] The methods used today when mixing road surfacing material are hot mixing and cold mixing.

[0003] Hot mixing requires stationary plants, in which a bituminous binder and gravel material are mixed during heating. The road surfacing material must then be transported to the road which is to be coated.

[0004] WO A1 83/00700 discloses a batchwise method and an apparatus for hot mixing of asphalt concrete. In this method and in this apparatus, heated aggregate is divided into three different particle sizes by screening. The coarse-grained portion (> 3 mm) is mixed with a hot bituminous binder. The hot bituminous binder covers the surface of the particles of the coarse-grained portion. After thorough mixing of the bituminous binder and the coarse-grained portion, a filler (< 0.1 mm) is added to increase the thickness of the bituminous film on the particles of the coarse-grained portion. Only then is the fine-grained portion (< 2 mm) added, which thus has a greater particle size than the filler and which is added to the thickened layer of bitumen on the particles of the coarse-grained portion. The adding of the filler results, in hot mixing, in the particles of the fine-grained portion more easily adhering to the particles already coated with the bituminous binder.

[0005] A problem in today's hot mixing is the large amounts of diesel oil, solvent and dust emitted to the surroundings during heating and working of the road surfacing material. The increasing cost for transporting the heated road surfacing material is an additional problem.

[0006] In order to avoid these problems of emission and heavy transport expenses, one has tried more and more to switch over to cold-mixed road surfacing materials which can be mixed in mobile plants on the site of spreading.

[0007] In cold mixing, it is thus possible to avoid the problem of various emissions and to reduce the transport expenses in connection with the spreading of the road surfacing material.

[0008] US-A-4,974,993 discloses a method and a device for renewing a road surface. In this method and in this device, the road material is first scarified and screened in order to separate particles > 35 mm from particles having the size of 0-35 mm. The reason for such screening is that subsequently the material having a particle size of > 35 mm is to be crushed to a smaller size. The particles of the two different portions, which are then united, thus have essentially the same size range. A solvent and a bitumen emulsion are then added to the crushed portion, which is then mixed with the portion that has not been subjected to crushing.

[0009] WO A1 87/03317 discloses a method and an apparatus for mixing gravel material and a bitumen emulsion. In this method and in this apparatus, the grav-

el material is separated into two portions. The two different portions are separately sprayed with the bitumen emulsion and are then united. The two portions sprayed with bitumen emulsion are then mixed together by letting the material fall freely onto strongly inclined baffles. Any remaining bitumen emulsion is added to the total mix of the two portions before being discharged from the apparatus.

[0010] Cold mixing has, in turn, caused new problems which are connected with the final road surfacing. One problem is that a separation occurs between the large and small particles of the gravel material, and this results in a non-uniform road surfacing material and stones coming loose from the finished road surface. Owing to the forming of lumps and stones coming loose, the road surface will be of non-uniform, unsatisfactory quality for coating busy roads.

[0011] One object of the present invention is to provide a road surfacing material without any problems of emission of various chemicals and dust.

[0012] A further object is to provide a road surfacing material which is of uniform composition after cold mixing and which, when being spread, does not cause the forming of lumps and the coming-loose of stones.

[0013] Other objects as well as features and advantages of the present invention will be apparent from the following description.

[0014] These objects are achieved by a method and a device according to the accompanying independent claims. Particularly preferred embodiments are defined in the subclaims.

[0015] Briefly, the present invention relates to a method and a device for continuous cold mixing of road surfacing material. Aggregate is supplied to a hopper, weighed on a belt weigher and conveyed to a screen to be separated into different size ranges. The different portions are then supplied to a compulsory mixer in which they are cold mixed with bitumen emulsion. According to the invention, the aggregate is screened continuously into at least three portions which are supplied to the compulsory mixer via different inlets.

[0016] The portion having the greatest particle size is first mixed with an excess of bitumen emulsion for this portion. Each aggregate portion of successively decreasing particle size is then separately mixed with an excess of bitumen emulsion for that aggregate portion at the same time as it is successively mixed with the aggregate portion/s already mixed with bitumen and having a greater particle size. Last of all, the aggregate portion/s having the smallest particle size/s is/are mixed with the aggregate portions already mixed with bitumen, without additional bitumen emulsion being supplied separately to this/these aggregate portion/s having the smallest particles.

[0017] Bitumen emulsion is supplied via nozzles which are arranged in the vicinity of the inlets for the aggregate portion/s having the greatest particle size/s, no nozzle being arranged adjacent the inlet for the ag-

gregate portion/s having the smallest particle size/s.

[0018] The advantage of the present invention is that a road surfacing material of uniform composition is obtained, which, when being spread, yields a road surface of high and uniform quality, without problems of lumps being formed and stones coming loose.

[0019] By the term aggregate is meant new aggregate in the form of crushed stones and recovery masses, i. e. scarified masses, having a predetermined size distribution.

[0020] Preferred embodiments of the present invention will now be described with reference to the accompanying drawings. These embodiments must not be considered restrictive to the scope of the present invention.

[0021] Fig. 1 is a principle sketch of a preferred embodiment of the entire inventive device, and

[0022] Fig. 2 is a principle sketch of an enlarged portion of a preferred embodiment of the screening and mixing device according to the invention.

[0023] The embodiment of the inventive device as illustrated in Fig. 1 comprises a hopper 1 whose lower part is provided with a conveyor belt 2. Under the discharge end of the conveyor belt 2, a belt weigher 3 is arranged. Adjacent the belt weigher 3, there is a further conveyor belt 4. The discharge end of this conveyor belt 4 opens into an inlet 5 of a screen 6. Under the screen 6, a compulsory mixer 7 is arranged. Fig 2 is an enlarged longitudinal section of the screen 6 and the compulsory mixer 7. The screen comprises two different grading screens 8a, 8b which open into different inlets 9a, 9b of the compulsory mixer 7. In the compulsory mixer 7 there are a number of nozzles 10a, 10b, 10c and an agitator 11, in which three of four agitator blades 12 propel the material in the direction of arrow 13, whereas the fourth agitator blade 12 propels the material in the opposite direction.

[0024] In the continuous cold mixing of the road surfacing material, the aggregate is first supplied to the hopper 1. Then the aggregate is conveyed continuously to the belt weigher 3 which registers the weight of the aggregate which is to be supplied to the screen 6 and the compulsory mixer 7. Subsequently, the aggregate is conveyed to the inlet 5 of the screen 6. Now the aggregate is discharged and falls onto the grading screen 8a which separates the smallest particles. The largest particles thus do not pass through this grading screen 8a but roll along this screen into the inlet 9a, in which the particles are mixed with an excess of bitumen emulsion for this portion, said bitumen emulsion being discharged from the nozzle 10a in the vicinity of the inlet 9a.

[0025] The particles which pass through the first grading screen 8a then impinge upon a new grading screen 8b, and the particles having a greater particle size than allowed by the grading limit of the grading screen 8b roll along the grading screen 8b down into the inlet 9b of the compulsory mixer 7, while an excess of bitumen emulsion for this portion is supplied via the nozzle 10b.

[0026] The particles that have passed through the two grading screens are supplied to the compulsory mixer over a longer distance and are mixed with the other portions of greater particle size, which have already been mixed with an excess of bitumen emulsion. From the nozzle 10c, the remaining bitumen emulsion is then supplied that is required for the total road surfacing material to have the correct consistency.

[0027] It is not always necessary to add any remaining bitumen emulsion via the nozzle 10c. It may also happen that all the bitumen emulsion has been supplied before adding the aggregate portion/s having the smallest particle size.

[0028] The added quantity of bitumen emulsion in the different nozzles 10a, 10b, 10c is controlled by the measured input weight of the aggregate that is measured on the belt weigher 3. The proportions of the output quantities in the different nozzles are controlled on the basis of the known size distribution of the aggregate.

[0029] When the largest particles are first mixed with an excess of bitumen emulsion, bitumen emulsion is immediately deposited and adheres to the large particles. Since there is an excess of bitumen emulsion around the large particles, the fine material adheres to these stones and there will be a minimum of separation. The ready-mixed road surfacing material is uniform, and the quality of the final road surface will be uniform and high.

30 Claims

1. A method for cold mixing of road surfacing material, comprising the steps of supplying aggregate to a hopper, weighing the aggregate on a belt weigher and conveying it to a screen to be separated into different size ranges, whereupon the different portions are supplied to a compulsory mixer in which they are cold mixed with bitumen emulsion, **characterised by** the steps of
 - continuously separating the aggregate, before mixing with the bitumen emulsion, into at least three portions in the screen,
 - subsequently mixing the portion having the largest particles with an excess of bitumen emulsion for this portion,
 - separately mixing each aggregate portion of successively decreasing particle size, except the aggregate portion/s having the smallest particle size/s, also with an excess of bitumen emulsion for that aggregate portion, while successively mixing it with the already bitumen-mixed aggregate portion/s having a greater particle size, and
 - subsequently mixing the aggregate portion/s having the smallest particle size/s with the previously bitumen-mixed aggregate portions, without additional bitumen emulsion being separately supplied to this or these aggregate portions having the smallest particles.

2. The method as claimed in claim 1, **characterised in that** the remaining bitumen emulsion, which is required to obtain the correct consistency of the total road surfacing material, is added and mixed with the road surfacing material after the aggregate portion/s having the smallest particle sizes being supplied.
3. The method as claimed in claim 1, **characterised in that** all the bitumen emulsion is added before admixing the aggregate portion/s having the smallest particle size.
4. A device for continuous cold mixing of road surfacing material containing aggregate and bitumen emulsion, said device comprising a hopper (1) for the aggregate, a screen (6), a compulsory mixer (7), a conveyor belt (2) for conveying the aggregate from the hopper (1) to the screen (6), and a belt weigher (3) for weighing the aggregate supplied from the hopper (1) to the screen (6), the screen (6) being arranged over the compulsory mixer (7), **characterised in that** the screen (6) is arranged to separate the aggregate discharged from the hopper (1) into at least three portions having different particle sizes before supplying the aggregate to the compulsory mixer (7), that the compulsory mixer (7) has different inlets (9a, 9b) for the portions separated in the screen (6) according to particle size, and that nozzles (10a, 10b) for bitumen emulsion are arranged in the vicinity of at least the inlets (9a, 9b) for the portion/s having the greatest particle size/s, while preferably no nozzle is arranged adjacent the inlet for the portion/s having the smallest particle size/s.
5. The device as claimed in claim 4, **characterised in that** a nozzle (10c) is arranged after the inlet for the portion having the smallest particle size.

Patentansprüche

1. Verfahren zum Kaltmischen eines Straßenbelagmaterials, das die Schritte des Zuführens von Zuschlagstoff zu einem Schüttbehälter, des Wiegens des Zuschlagstoffes auf einer Bandwaage und des Beförderns desselben zu einer Siebvorrichtung, um ihn in verschiedene Größenbereiche zu trennen, umfasst, wobei anschließend die verschiedenen Bestandteile einem Zwangsmischer zugeführt werden, in dem sie mit Bitumenemulsion kaltgemischt werden, **gekennzeichnet durch** die folgenden Schritte:

kontinuierliches Trennen des Zuschlagstoffes vor dem Mischen mit der Bitumenemulsion in wenigstens drei Bestandteile in der Siebvor-

richtung,

anschließendes Mischen des Bestandteils mit den größten Teilchen mit einem Überschuss an Bitumenemulsion für diesen Bestandteil,

separates Mischen jedes Zuschlagstoff-Bestandteils schrittweise kleiner werdender Teilchengröße bis auf den/die Zuschlagstoff-Bestandteil/e mit der/den kleinsten Teilchengröße/n ebenfalls mit einem Überschuss an Bitumenemulsion für diesen Zuschlagstoff-Bestandteil, wobei er schrittweise mit dem/den bereits mit Bitumen vermischten Zuschlagstoff-Bestandteil/en gemischt wird, die eine größere Teilchengröße aufweisen, und

anschließendes Mischen des/der Zuschlagstoff-Bestandteils/Bestandteile mit der/den kleinsten Teilchengröße/n mit den zuvor mit Bitumen vermischten Zuschlagstoff-Bestandteilen, ohne dass diesem bzw. diesen Zuschlagstoff-Bestandteil/en mit den kleinsten Teilchen separat zusätzliche Bitumenemulsion zugeführt wird.

2. Verfahren nach Anspruch 1, **dadurch gekennzeichnet, dass** die verbleibende Bitumenemulsion, die erforderlich ist, um die richtige Konsistenz des gesamten Straßenbelagmaterials zu erzielen, dem Straßenbelagmaterial zugesetzt und mit ihm vermischt wird, nachdem der/die Zuschlagstoff-Bestandteil/e mit den kleinsten Teilchengrößen zugeführt wurde.
3. Verfahren nach Anspruch 1, **dadurch gekennzeichnet, dass** die gesamte Bitumenemulsion zugesetzt wird, bevor der/die Zuschlagstoff-Bestandteil/e mit der kleinsten Teilchengröße beigemischt wird/werden.
4. Vorrichtung zum kontinuierlichen Kaltmischen eines Straßenbelagmaterials, das Zuschlagstoff und Bitumenemulsion enthält, wobei die Vorrichtung einen Schüttbehälter (1) für den Zuschlagstoff, eine Siebvorrichtung (6), einen Zwangsmischer (7), ein Förderband (2), das den Zuschlagstoff von dem Schüttbehälter (1) zu der Siebvorrichtung (6) befördert, und eine Bandwaage (3) umfasst, mit der der von dem Schüttbehälter (1) der Siebvorrichtung (6) zugeführte Zuschlagstoff gewogen wird, wobei die Siebvorrichtung (6) über dem Zwangsmischer (7) angeordnet ist, **dadurch gekennzeichnet, dass** die Siebvorrichtung (6) den aus dem Schüttbehälter (1) abgegebenen Zuschlagstoff in wenigstens drei Bestandteile mit unterschiedlichen Teilchengrößen trennt, bevor der Zuschlagstoff dem Zwangsmischer (7) zugeführt wird, dass der Zwangsmischer

(7) unterschiedliche Einlasse (9a,9b) für die in der Siebvorrichtung (6) getrennten Bestandteile entsprechend der Teilchengröße aufweist, und dass Düsen (10a, 10b) für Bitumenemulsion in der Nähe wenigstens der Einlasse (9a,9b) für den/die Bestandteil/e mit der/den größten Teilchengröße/n angeordnet sind, wobei vorzugsweise keine Düse an den Einlass für den/die Bestandteil/e mit der/den kleinsten Teilchengröße/n angrenzend angeordnet ist.

5. Vorrichtung nach Anspruch 4, **dadurch gekennzeichnet, dass** eine Düse (10c) hinter dem Einlass für den Bestandteil mit der kleinsten Teilchengröße angeordnet ist.

Revendications

1. Procédé de mélange à froid d'un matériau de couche de surface de route, comprenant des étapes de transmission d'un agrégat à une trémie, de pesée de l'agrégat sur une bascule à courroie et de son transport vers un crible afin qu'il soit séparé en fractions granulométriques différentes, dans lequel les fractions différentes sont transmises à un mélangeur obligatoire dans lequel elles sont mélangées à froid avec une émulsion de bitume, **caractérisé par** les étapes suivantes :

la séparation continue de l'agrégat, avant le mélange avec l'émulsion de bitume, en au moins trois fractions dans le crible,

le mélange ultérieur de la fraction ayant les plus grosses particules avec un excès d'émulsion de bitume correspondant à cette fraction,

le mélange séparé de chaque fraction d'agrégat de dimension particulière diminuant progressivement, sauf la fraction ou les fractions d'agrégat ayant la plus petite ou les plus petites dimensions particulières, toujours avec un excès d'émulsion de bitume pour cette fraction d'agrégat, avec mélange successif avec la fraction ou les fractions d'agrégat déjà mélangées avec du bitume et ayant une plus grande dimension particulière, et

le mélange ultérieur de la fraction ou des fractions d'agrégat ayant la dimension ou les dimensions particulières les plus petites aux fractions d'agrégat antérieurement mélangées à du bitume, sans transmission séparée d'émulsion supplémentaire de bitume à cette fraction ou ces fractions d'agrégat ayant les particules les plus petites.

2. Procédé selon la revendication 1, **caractérisé en ce que** l'émulsion restante de bitume qui est nécessaire pour l'obtention de la consistance convenable

du matériau total de couche de surface de route est ajoutée et mélangée au matériau de couche de surface de route après que la fraction ou les fractions d'agrégat de plus petite dimension particulière ont été transmises.

3. Procédé selon la revendication 1, **caractérisé en ce que** toute l'émulsion de bitume est ajoutée avant le mélange de la fraction ou des fractions d'agrégat ayant la dimension particulière la plus petite.

4. Appareil de mélange continu à froid d'un matériau de couche de surface de route, contenant un agrégat et une émulsion de bitume, l'appareil comprenant une trémie (1) destinée à l'agrégat, un crible (6), un mélangeur obligatoire (7), une courroie transporteuse (2) destinée au transport de l'agrégat de la trémie (1) au crible (6), et une bascule à courroie (3) destinée à peser l'agrégat transmis par la trémie (1) au crible (6), le crible (6) étant placé au-dessus du mélangeur obligatoire (7), **caractérisé en ce que** le crible (6) est destiné à séparer l'agrégat évacué de la trémie (1) en au moins trois fractions ayant des dimension particulières différentes avant transmission de l'agrégat au mélangeur obligatoire (7), **en ce que** le mélangeur obligatoire (7) a des entrées différentes (9a, 9b) pour les fractions séparées dans le crible (6) en fonction de la dimension particulière, et **en ce que** des buses (10a, 10b) d'émulsion de bitume sont placées au voisinage au moins des entrées (9a, 9b) de la fraction ou des fractions ayant la dimension ou les dimensions particulières les plus grandes, alors que de préférence aucune buse n'est placée près de l'entrée de la fraction ou des fractions ayant la dimension ou les dimensions particulières les plus petites.

5. Dispositif selon la revendication 4, **caractérisé en ce qu'**une buse (10c) est placée après l'entrée de la fraction ayant la plus petite dimension particulière.

Fig. 1

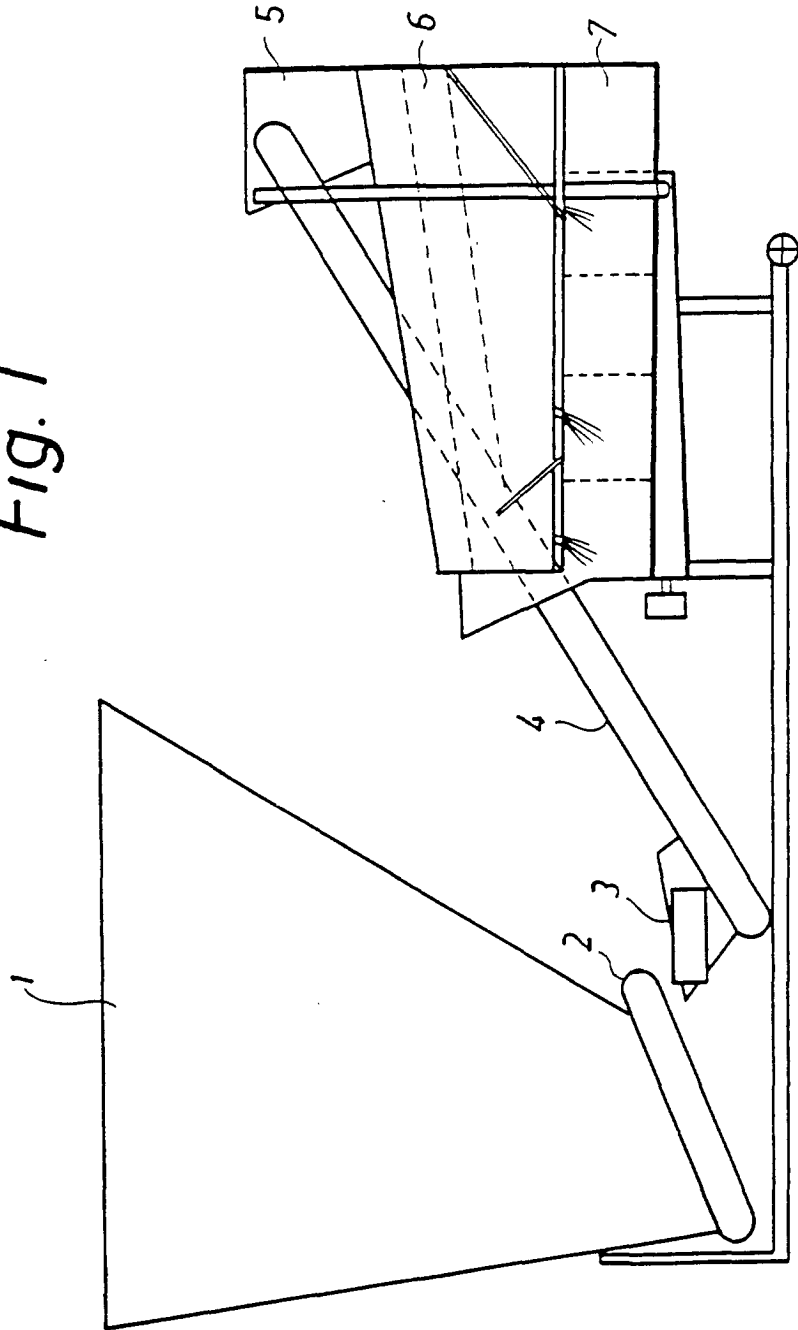

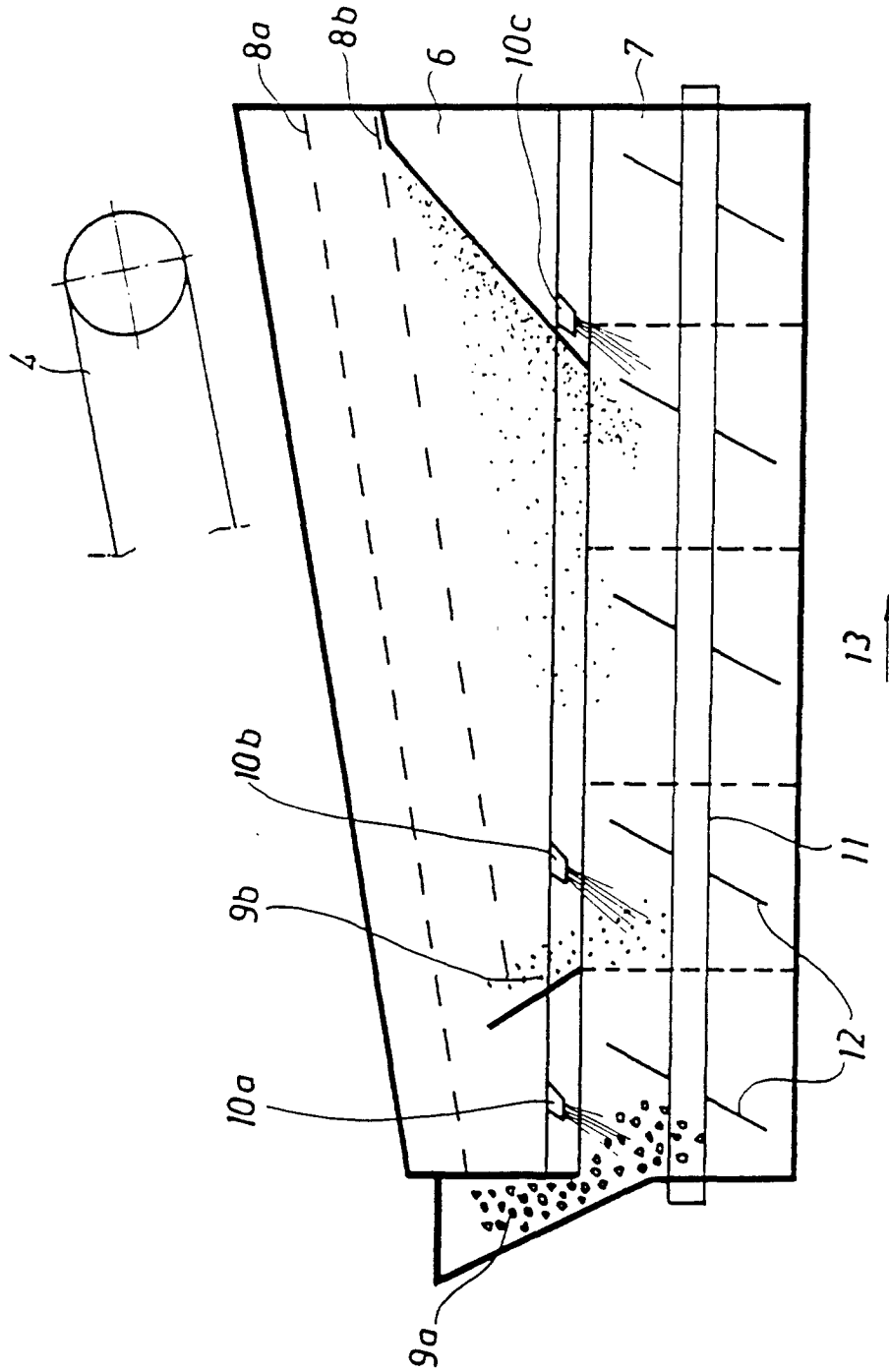

Fig. 2