

Aug. 6, 1935.

W. McCONALOGUE

2,010,551

DEVICE FOR READING OF X-RAY FILMS

Filed March 8, 1934

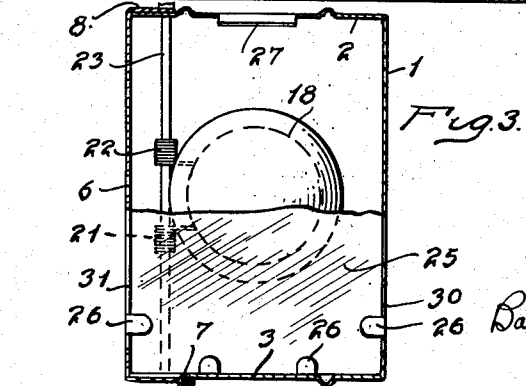
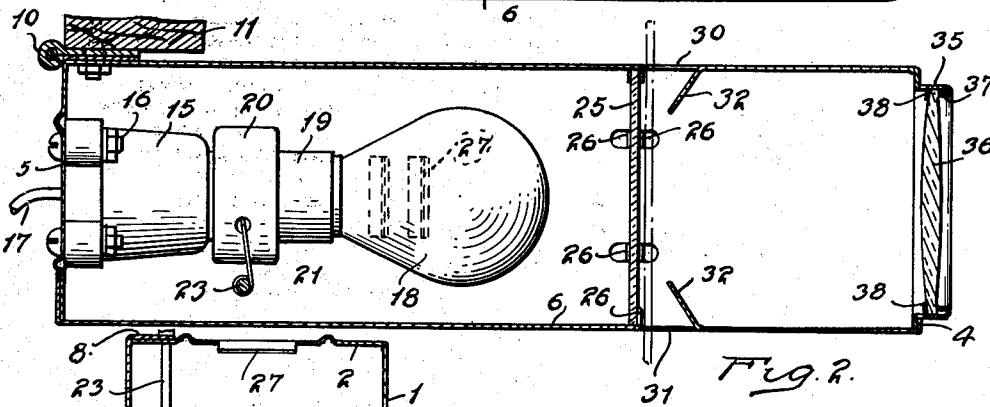
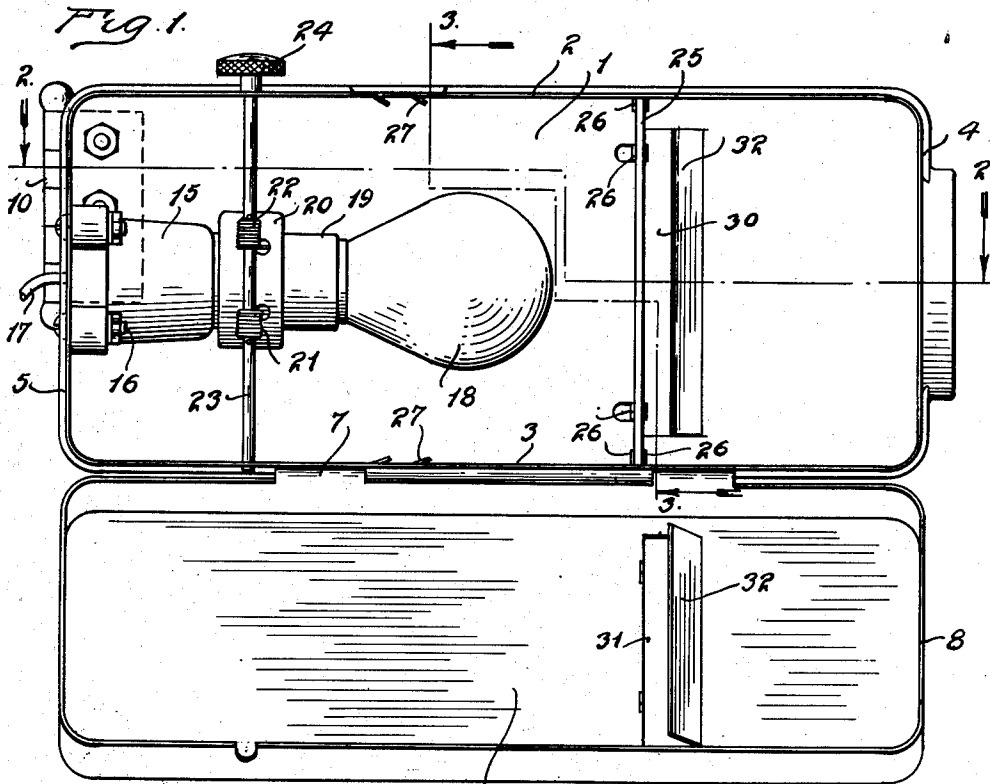

INVENTOR.
WESLEY Mc CONALOGUE

BY
Dames, Kisselle, Laughlin & Raich
ATTORNEYS.

UNITED STATES PATENT OFFICE

2,010,551

DEVICE FOR READING OF X-RAY FILMS

Wesley McConalogue, Detroit, Mich.

Application March 8, 1934, Serial No. 714,580

5 Claims. (Cl. 40-132)

This invention has to do with a device for the reading of X-ray films. The art of interpreting X-ray films is one which deals largely with shadows and varying density effects. In dentistry, for example, the use of the X-ray in considering and studying the bony structure of the jaw is increasing, as the condition of such bony structure may even indicate in advance conditions to be expected in teeth.

According to the invention the film is lighted by suitable light source such as an incandescent lamp, and inasmuch as different films vary in density, an arrangement is provided to vary the incandescence of the lamp. The device also includes means for diffusing the light so that the film is subjected more or less uniformly to light over its surfaces, and the arrangement is such that the film may be quickly placed in position or removed. A lens is preferably incorporated in the device which is used to magnify the showing on the film, and this is particularly useful in the detail consideration of small films, for example, films of the bony structure of a jaw.

In the accompanying drawing:

Fig. 1 is a view of a device constructed in accordance with the invention, the view being in side elevation, and with one side of the device open to show the interior structure.

Fig. 2 is a sectional view taken substantially on line 2-2 of Fig. 1.

Fig. 3 is a sectional view taken on line 3-3 of Fig. 1.

The device for carrying out the invention may be of a simple structure and in fact it may be in the form of a casing or box preferably arranged to be suitably mounted. The box may be made of sheet metal. As shown in Fig. 1 the device may be in the form of a box having a side wall 1, other walls 2 and 3 which may be termed top and bottom walls, inasmuch as these happen to be top and bottom walls as the device is shown herein, walls 4 and 5, and another side wall 6 which may be hinged to the major portion of the device as at 7. The wall 6 may have a rim 8 for telescopically fitting over the main portion of the box. Any suitable fastening means may be used for holding the wall 6 in place.

The box may be suitably mounted, as for example, on a hinge 10 so that it may be swung outwardly from a wall or other support 11 for use and swung into close proximity therewith when not in use. One end of the box is arranged to accommodate a light source, preferably an incandescent lamp. A suitable base or support therefore is shown at 15 fastened to the end wall

5 as by means of bolts or the like 16 while the conductor is shown at 17 leading into the box. The lamp is illustrated at 18 in a socket 19 preferably equipped with a controlling device for controlling, varying or changing the incandescence of the lamp. Such controlling devices are now available on the market and one is illustrated herein within a housing 20. The control is effected by shifting flexible elements such as small chains, cords or small cables 21 and 22 which extend into the housing 23 and are oppositely wound upon a control shaft 23. The shaft is journaled in the box and has an outside operating piece 24. By turning the member 24 the incandescence of the lamp is varied.

Forwardly of the lamp is positioned a light diffusing device 25 advantageously in the form of a piece of glass of opalescent or frosted variety. This glass may be held in place by wings 26 struck out of the sheet metal sides of the box and the glass may be placed into or removed from the closure by opening of the wall 6. This piece of glass divides the box into two compartments with the lamp in one of the compartments. For ventilating purposes some of the walls may be provided with struck out portions 27 to thus form louvers for the flow of air currents through the light compartment, thus serving to cool the same.

The film compartment is on the right hand side of the diffusion glass as Fig. 1 is viewed, and the walls 1 and 6 are slotted as at 30 and 31 so that a film may be passed into or through the compartment on the side of the glass opposite the light source. These slots may be provided by striking out wings 30 or 31 and leaving them substantially in the position as shown, thus to define the portion of the film visible for consideration, and to also serve to keep out other light. Thus the slots 30 and 31 may be of generous portions making it very easy to insert a film with the struck-out portions 32 serving to guide the film into place and serving to in effect reduce the size of the openings 30 and 31.

The end 4 may be provided with a collar like formation 35 of circular form for holding a magnifying glass or lens 36. The end of the collar may be fashioned over as at 37 for abutting against one side of the lens and struck out portions 38 may hold the lens from the opposite side.

In the use of the device an operator may stand so as to look into the box through the lens 36 and then the film may be positioned by insertion through one of the slots 30 or 31. The glass 36 magnifies the size of the forms on the film so that they may be studied in detail and the in-

candescence of the lamp 18 may be varied by manipulation of the operating piece 24. As above mentioned this light may be varied in the consideration of shadows of varying densities in a given film and may be varied also in consideration of separate films of different densities. The lamp 18 is advantageously one of the variety which provides illumination simulating daylight. To this end the lamp may be blued. In some cases, however, where a dark room effect is desired, a red light may be used.

I claim:

1. A device for reading X-ray films, comprising a box, a light diffusing glass intermediate the ends of the box dividing the box into compartments, a light source in one compartment, said box being of sheet metal, one or more walls of the other compartment having inwardly struck wings providing openings for the insertion of a film located relatively close to the diffusing glass and remote from the end of the box at the second compartment, and the end of the box at the second compartment having an inspection opening therein.

2. A device for reading X-ray films, comprising a box, a light diffusing glass intermediate the ends of the box dividing the box into compartments, a light source in one compartment, said box being of sheet metal, one or more walls of the other compartment having inwardly struck wings providing openings for the insertion of a film, and the end of the box at the second compartment having an inspection opening therein, said wings extending angularly and inwardly toward the light diffusing glass and away from the inspection opening.

3. A device for reading X-ray films, comprising a box, a light diffusing glass intermediate the ends of the box dividing the box into compartments, and a light source in one compartment, said box being of sheet metal, one or more walls of the other compartment having inwardly struck wings providing openings for the insertion of a

film, and the end of the box at the second compartment having an inspection opening therein, said wings extending angularly and inwardly toward the light diffusing glass and away from the inspection opening to define the area on the film which is visible from the inspection opening, and a magnifying lens in the inspection opening.

4. A device for reading X-ray films, comprising an elongated box, a light source in one end of the box, an inspection opening at the other end of the box, a light diffusing glass between the inspection opening and the light source and spaced from the inspection opening, the box walls having one or more slots therein for the passage therethrough of a film between the light diffusing glass and the inspection opening, and means hingedly mounting the box to a support at a corner adjacent the end of the box having the light source.

5. A device for reading X-ray films comprising a box, a cover for the box for closing the same and openable for access to the interior of the box, a light diffusing element in the box dividing the same into compartments, a light source in one compartment, the wall of the box opposite the compartment with the light source having an inspection opening therein, a lens in said opening, some of the walls of the box being of sheet metal, at least one of the sheet metal walls having a slot therein formed by cut-away sheet metal, the said slot communicating with the compartment next adjacent the inspection opening, and said slot being positioned in close proximity to the light diffusing element whereby film may be passed therethrough into the compartment next adjacent the inspection opening and positioned immediately adjacent the light diffusing element, and means on the box adjacent the end of the box with the light compartment for hingeably mounting the box to a support.

WESLEY McCONALOGUE.