



US00D749051S

(12) **United States Design Patent**  
**Clark et al.**

(10) **Patent No.:** **US D749,051 S**

(45) **Date of Patent:** **\*\* Feb. 9, 2016**

(54) **LIGHT EMITTING DIODE (LED) PACKAGE**

(71) Applicant: **CREE, Inc.**, Durham, NC (US)

(72) Inventors: **Joseph G Clark**, Raleigh, NC (US);  
**Amber C Abare**, Durham, NC (US);  
**David T Emerson**, Chapel Hill, NC (US);  
**Jeremy S Nevins**, Cary, NC (US);  
**Raymond Rosado**, Apex, NC (US)

(73) Assignee: **Cree, Inc.**, Durham, NC (US)

(\*\*) Term: **14 Years**

(21) Appl. No.: **29/439,629**

(22) Filed: **Dec. 13, 2012**

**Related U.S. Application Data**

(63) Continuation-in-part of application No. 29/423,422, filed on May 31, 2012, and a continuation-in-part of application No. 13/554,776, filed on Jul. 20, 2012.

(51) **LOC (10) CI.** ..... **13-03**

(52) **U.S. CI.**  
USPC ..... **D13/180**

(58) **Field of Classification Search**

USPC ..... D13/180; D26/1; 257/79, 80, 81, 88,  
257/89, 95, 98, 99, 100, E33.058; 313/483,  
313/498, 500; 362/555, 800

See application file for complete search history.

(56) **References Cited**

**U.S. PATENT DOCUMENTS**

4,946,547	A	8/1990	Palmour	
5,200,022	A	4/1993	Kong	
RE34,861	E	2/1995	Davis	
7,213,940	B1	5/2007	Van De Ven	
D615,504	S *	5/2010	Keller et al.	D13/180
7,791,061	B2	9/2010	Edmond	
D628,966	S *	12/2010	Kuwaharada et al.	D13/180
D631,020	S *	1/2011	Chuang et al.	D13/180
8,058,088	B2	11/2011	Cannon	
D650,343	S *	12/2011	Andrews et al.	D13/180
D658,139	S *	4/2012	Andrews et al.	D13/180
D660,257	S *	5/2012	Andrews et al.	D13/180

D674,758	S *	1/2013	Wu et al.	D13/180
D675,169	S *	1/2013	Chou	D13/180
8,575,734	B2	11/2013	Shin	
8,610,145	B2	12/2013	Yano	
D709,464	S	7/2014	Abare et al.	
D711,841	S	8/2014	Britt et al.	
D713,804	S	9/2014	Britt et al.	
2004/0262738	A1	12/2004	Lee et al.	
2007/0158668	A1	7/2007	Tarsa	
2008/0001160	A1	1/2008	Andrews	
2008/0026498	A1	1/2008	Tarsa et al.	
2008/0035947	A1	2/2008	Weaver Jr. et al.	
2008/0054286	A1 *	3/2008	Loh et al.	257/98
2008/0074029	A1	3/2008	Suehiro	
2008/0173884	A1	7/2008	Chitnis	
2008/0179611	A1	7/2008	Chitnis	
2008/0258130	A1	10/2008	Bergmann	
2009/0050907	A1	2/2009	Yuan et al.	
2009/0108281	A1 *	4/2009	Keller et al.	257/98
2009/0146159	A1	6/2009	Park et al.	
2010/0140634	A1	6/2010	Van De Ven et al.	
2010/0155748	A1	6/2010	Chan et al.	
2010/0155763	A1	6/2010	Donofrio	
2010/0207534	A1	8/2010	Dowling et al.	
2010/0237377	A1	9/2010	Park	
2010/0237775	A1	9/2010	Chao	
2010/0252851	A1 *	10/2010	Emerson et al.	257/98
2010/0277919	A1	11/2010	Okada et al.	
2011/0012143	A1	1/2011	Yuan et al.	
2011/0062482	A1 *	3/2011	Solomensky et al.	257/99
2011/0127912	A1 *	6/2011	Lee et al.	315/32
2011/0220920	A1 *	9/2011	Collins et al.	257/88
2011/0220926	A1	9/2011	Kim	
2012/0069564	A1	3/2012	Andrews et al.	
2012/0086024	A1	4/2012	Andrews et al.	
2012/0199852	A1	8/2012	Lowes et al.	
2012/0286304	A1 *	11/2012	LeToquin et al.	257/89
2012/0305949	A1	12/2012	Donofrio	
2012/0326159	A1	12/2012	Bergmann	
2013/0092960	A1 *	4/2013	Wilcox et al.	257/88
2013/0105835	A1 *	5/2013	Wu et al.	257/89
2013/0322068	A1	12/2013	Clark et al.	
2013/0322070	A1	12/2013	Clark et al.	

**FOREIGN PATENT DOCUMENTS**

CN	ZL201230586339.6	7/2013
CN	302758425 S	3/2014
CN	ZL201330525210.9	6/2014
CN	ZL201330525357.8	6/2014
CN	ZL201330525231.0	7/2014
DE	102007029369 A1	1/2009
EP	2856524	4/2015

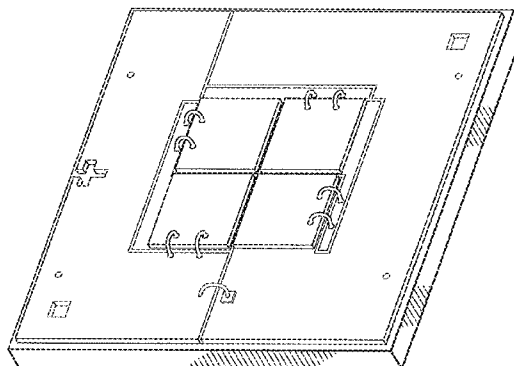
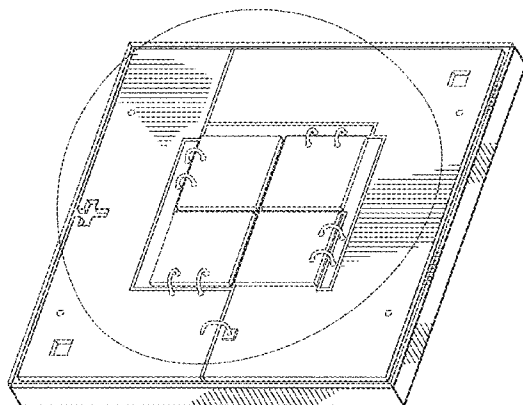

EP	2856525	4/2015
JP	2002-057374	2/2002
JP	2003-258310	9/2003
JP	2008-034513	2/2008
WO	WO 2013/181537	12/2013
WO	WO 2013/181538	12/2013

## OTHER PUBLICATIONS

Restriction Requirement for U.S. Appl. No. 13/554,776 dated Jun. 14, 2013.  
 Chinese Office Action for Application No. 201330248426.5 dated Aug. 19, 2013.  
 Chinese Notice of Grant for Application No. 201230586339.6 dated Apr. 15, 2013.  
 "High Flux Density and Efficacy;" Luxeon M Datasheet DS103, 2012, pp. 1-22, Philips Lumileds Company, United States.  
 Shehekin, Oleg et al., "Evolutionary new chip design targets lighting systems," Compound Semiconductor, Mar. 2007, vol. 13 No. 2, Institute of Physics Publishing and IOP Publishing Ltd.  
 International Search Report and Written Opinion for Application No. PCT/US2013/043618 dated Sep. 25, 2013.  
 International Search Report and Written Opinion for Application No. PCT/US2013/043619 dated Sep. 26, 2013.  
 Restriction Requirement for U.S. Appl. No. 29/423,422 dated Sep. 30, 2013.  
 Notice of Issuance for U.S. Appl. No. 201330248426.5 dated Nov. 19, 2013.  
 Notice of Allowance for Application No. 29/423,422 dated Nov. 19, 2013.  
 Chinese Office Action for Application No. 201330525231.0 dated Jan. 13, 2014.  
 Chinese Notice of Issuance for Application No. 201330525357.8 dated Feb. 19, 2014.  
 Chinese Notice of Issuance for Application No. 201330525210.9 dated Feb. 19, 2014.  
 Notice of Allowance for U.S. Appl. No. 29/423,422 dated Mar. 3, 2014.  
 Chinese Notice of Allowance for Application No. 201330525231.0 dated Apr. 10, 2014.  
 Non-Final Office Action for U.S. Appl. No. 13/554,776 dated Apr. 24, 2014.  
 U.S. Appl. No. 13/557,776, filed Jul. 20, 2012.  
 U.S. Appl. No. 13/713,410, filed Dec. 13, 2012.  
 U.S. Appl. No. 29/491,974, filed May 27, 2014.  
 Restriction Requirement for U.S. Appl. No. 13/713,410 dated Oct. 6, 2014.  
 Non-Final Office Action for U.S. Appl. No. 13/554,776 dated Jan. 12, 2015.  
 English Translation of DE 10 2007 029 369 A1 dated Jan. 1, 2009.  
 Restriction Requirement for U.S. Appl. No. 13/713,410 dated Feb. 26, 2015.  
 Non-Final Office Action for U.S. Appl. No. 13/713,410 dated Jul. 6, 2015.  
 Notice of Allowance for U.S. Appl. No. 29/491,974 dated Aug. 4, 2015.

\* cited by examiner

Primary Examiner — Selina Sikder

(74) Attorney, Agent, or Firm — Jenkins, Wilson, Taylor & Hunt, P.A.

## (57) CLAIM

The ornamental design for a light emitting diode (LED) package, as shown and described.

## DESCRIPTION

FIG. 1 is a top perspective view of a LED package showing our design according to a third embodiment;  
 FIG. 2 is a top plan view thereof;  
 FIG. 3 is a bottom plan view thereof, opposite the view of FIG. 2;  
 FIG. 4 is a first side view thereof;  
 FIG. 5 is a second side view thereof;  
 FIG. 6 is a third side view thereof, opposite the view of FIG. 4;  
 FIG. 7 is a fourth side view thereof, opposite the view of FIG. 5;  
 FIG. 8 is a top perspective view of an LED package showing our design according to a fourth embodiment;  
 FIG. 9 is a top plan view thereof;  
 FIG. 10 is a bottom plan view thereof, opposite the view of FIG. 9;  
 FIG. 11 is a first side view thereof;  
 FIG. 12 is a second side view thereof;  
 FIG. 13 is a third side view thereof, opposite the view of FIG. 11;  
 FIG. 14 is a fourth side view thereof, opposite the view of FIG. 12;  
 FIG. 15 is a top perspective view of a LED package showing our design according to a third embodiment;  
 FIG. 16 is a top plan view;  
 FIG. 17 is a bottom plan view;  
 FIG. 18 is first side view;  
 FIG. 19 is second side view;  
 FIG. 20 is third side view;  
 FIG. 21 is fourth side view;  
 FIG. 22 is a top perspective view of a LED package showing our design according to a fourth embodiment;  
 FIG. 23 is a top plan view;  
 FIG. 24 is a bottom plan view;  
 FIG. 25 is first side view;  
 FIG. 26 is second side view;  
 FIG. 27 is third side view; and,  
 FIG. 28 is fourth side view.

The broken lines are for illustrative purposes only and form no part of the claimed design. The gray or stippled trench portions of the embodiment illustrated in FIGS. 8, 9, 11, and 13 represent that the stippled portions are a different material having different visual effects than other, adjacent portions. The gray or stippled trace portions illustrated in FIGS. 22, 23, and 25-28 represent a metallic surface having a metallic visual effect.

1 Claim, 20 Drawing Sheets

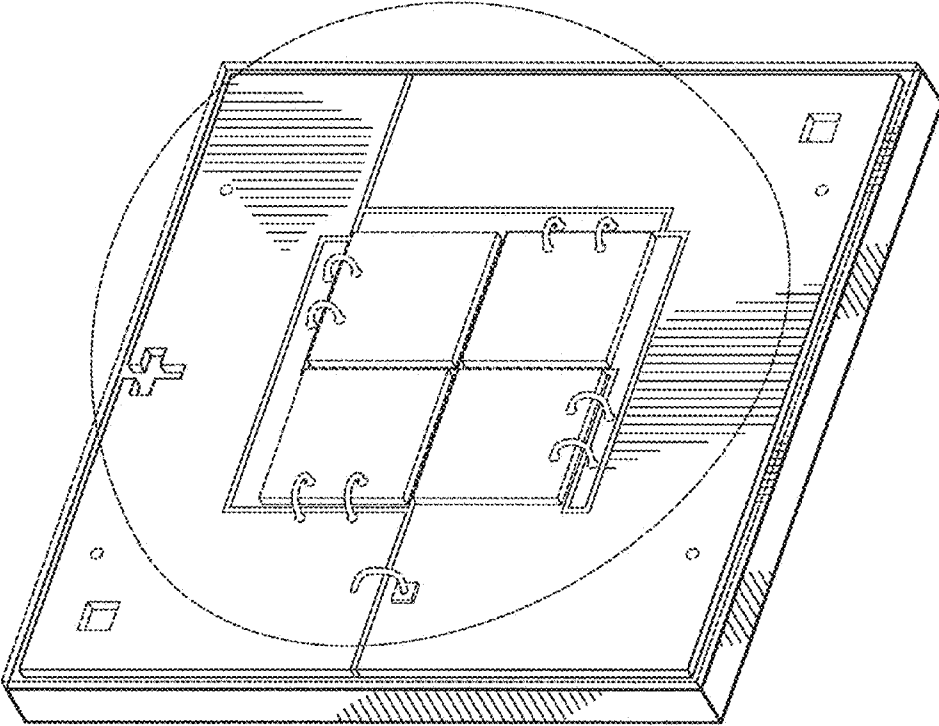

FIG. 1

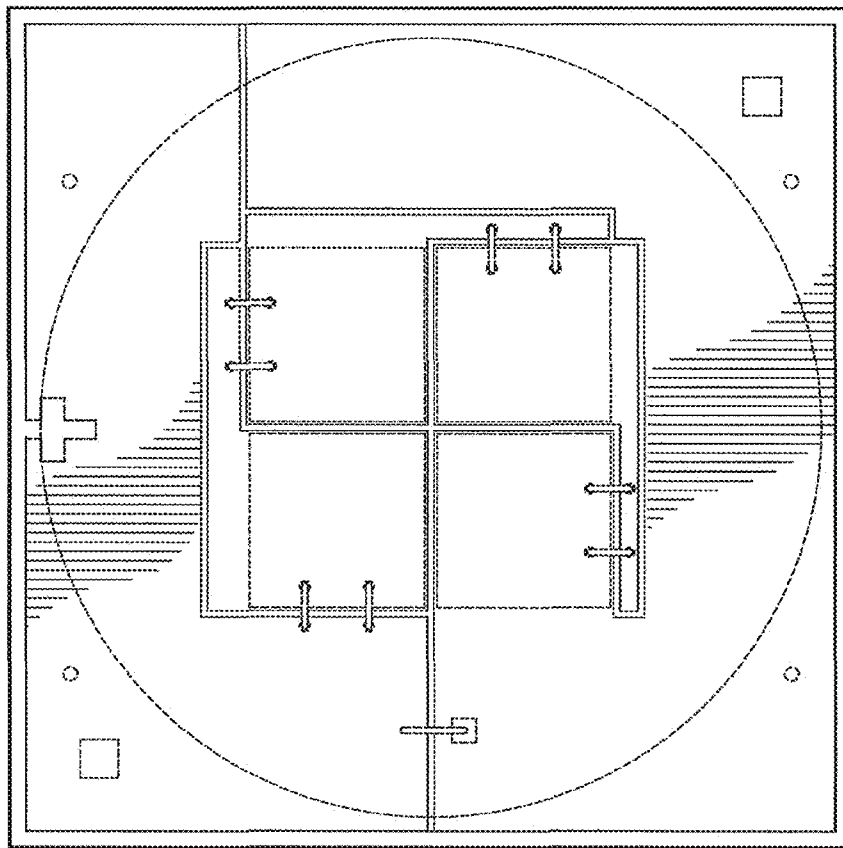

FIG. 2

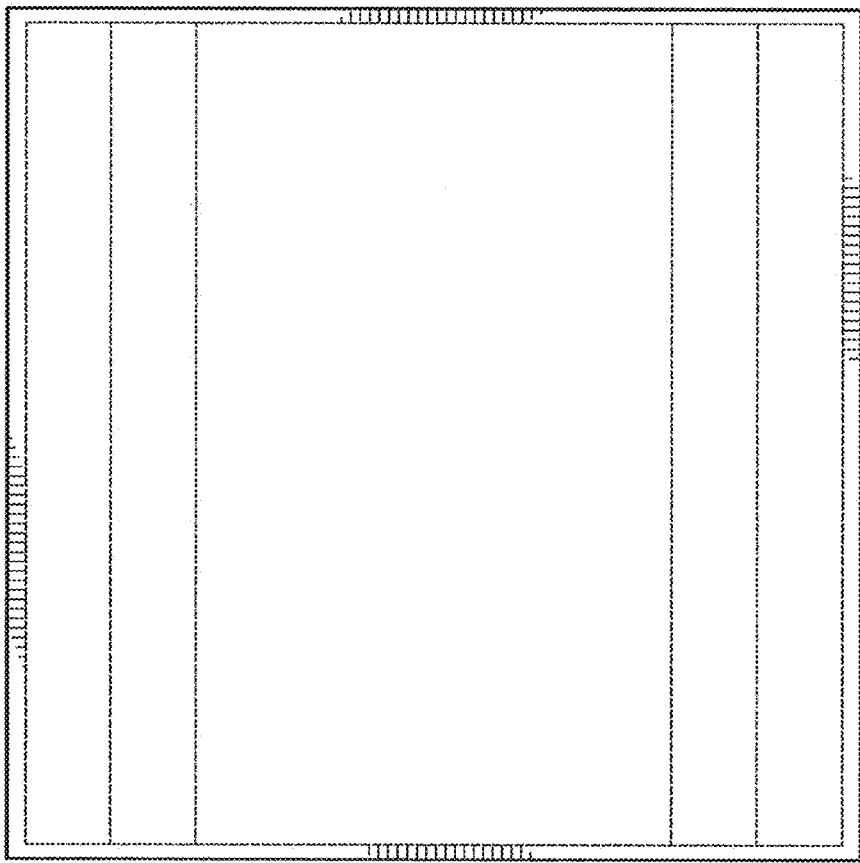

FIG. 3

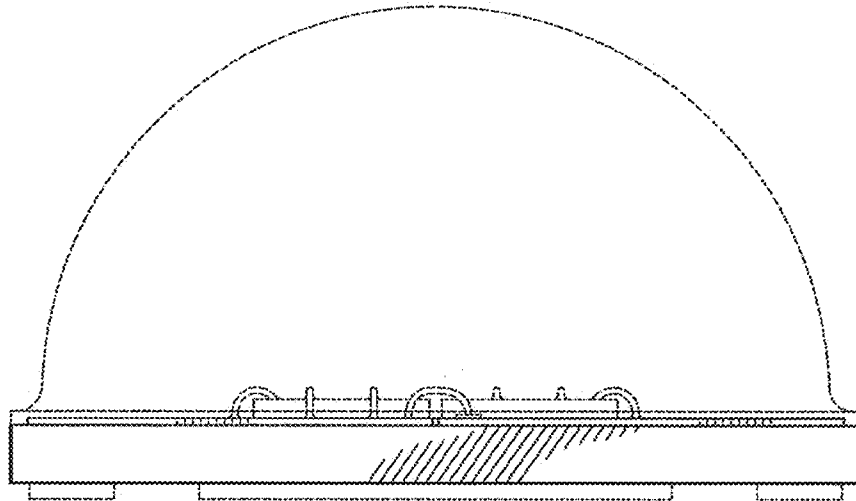

FIG. 4

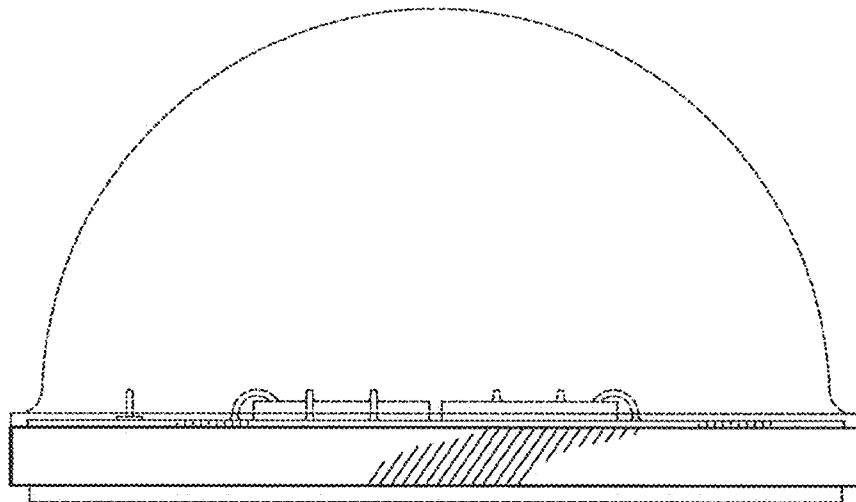

FIG. 5

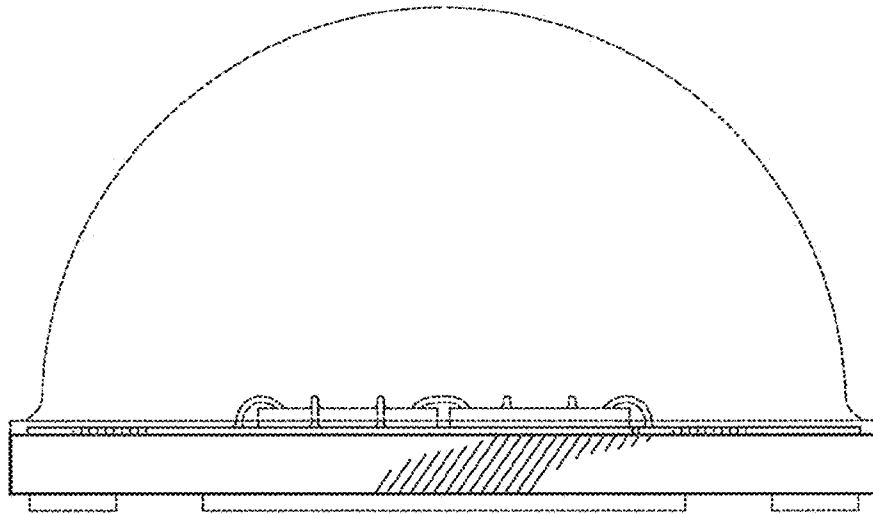

FIG. 6

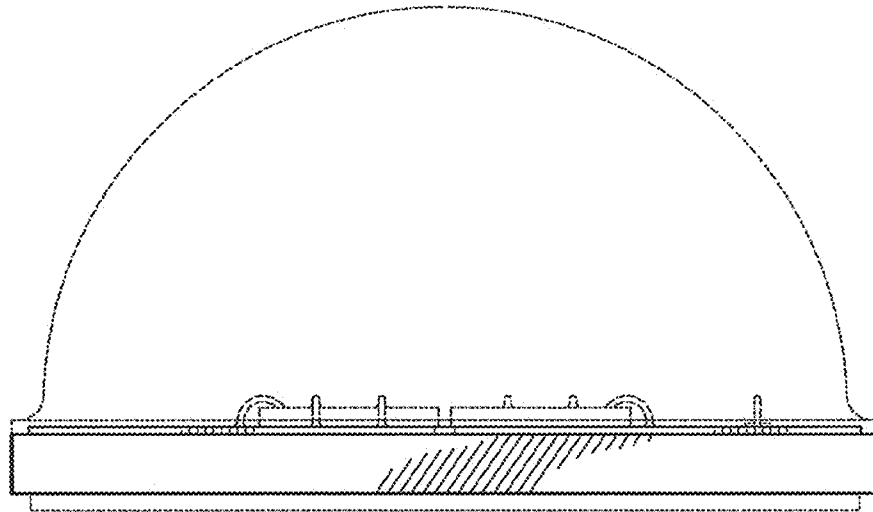

FIG. 7

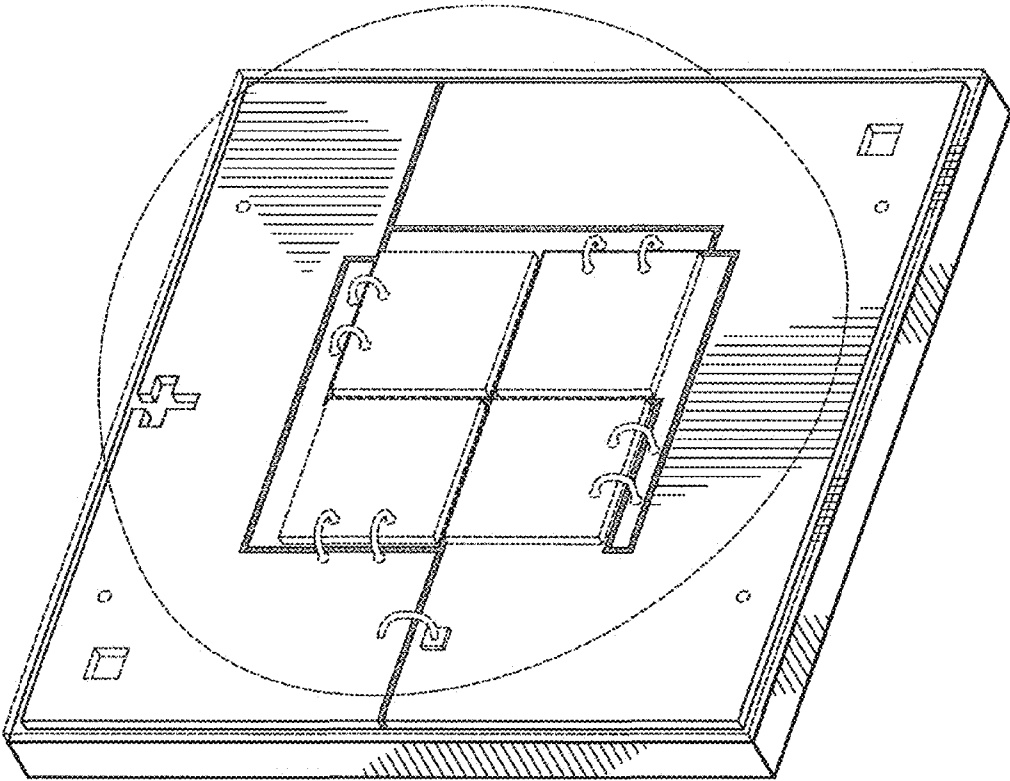

FIG. 8



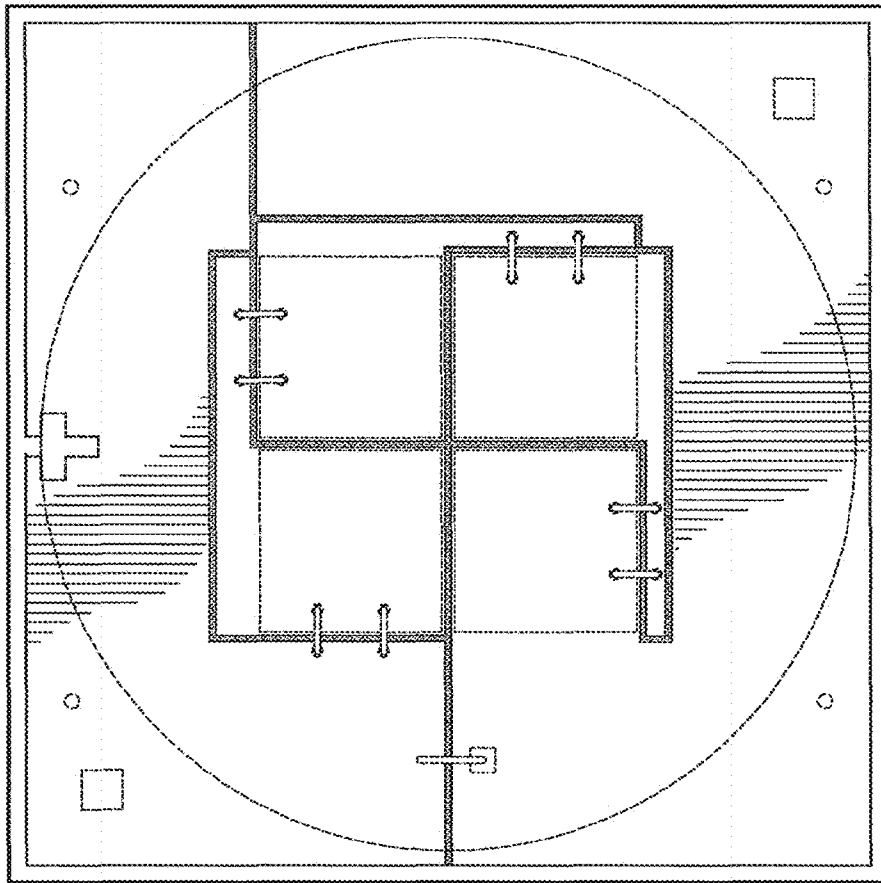

FIG. 9

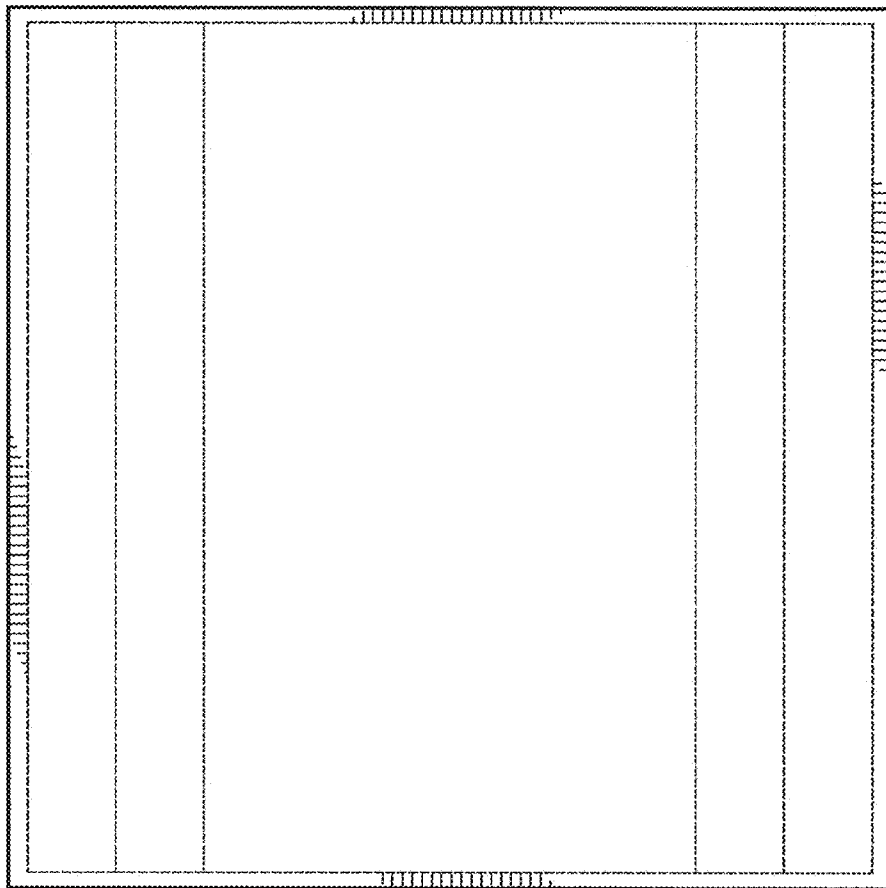

FIG. 10

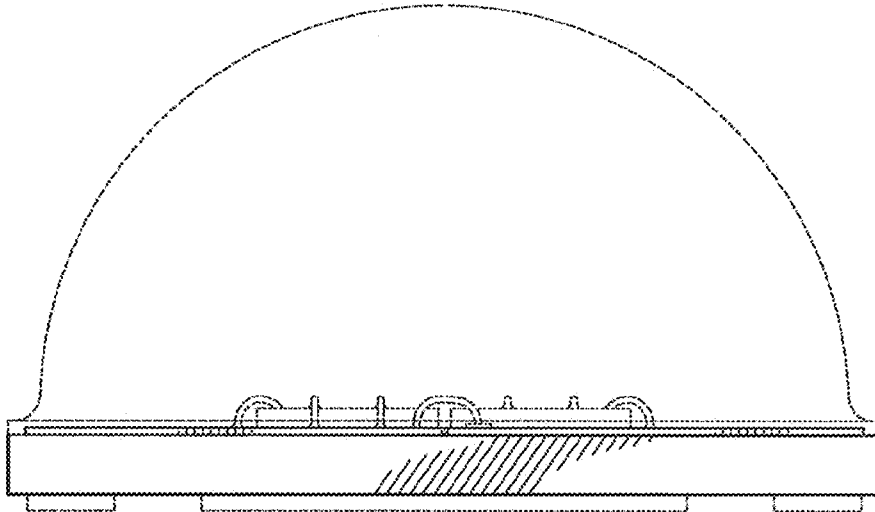

FIG. 11

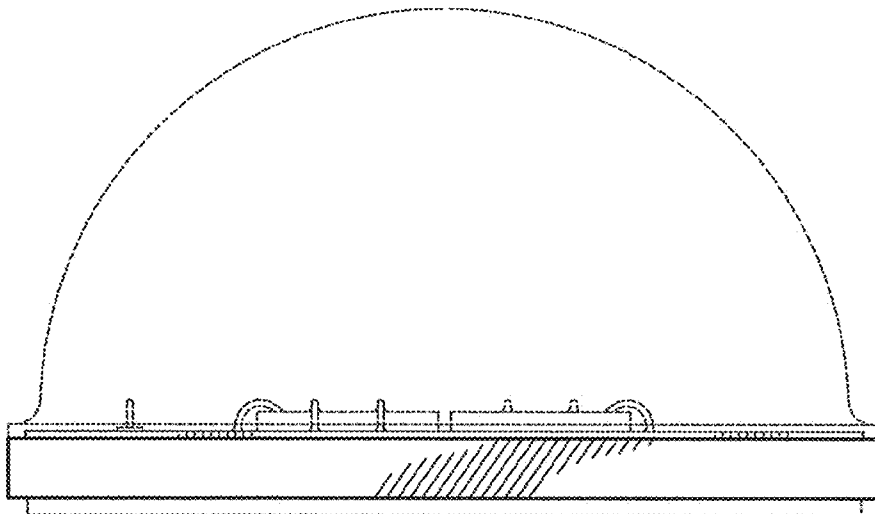

FIG. 12

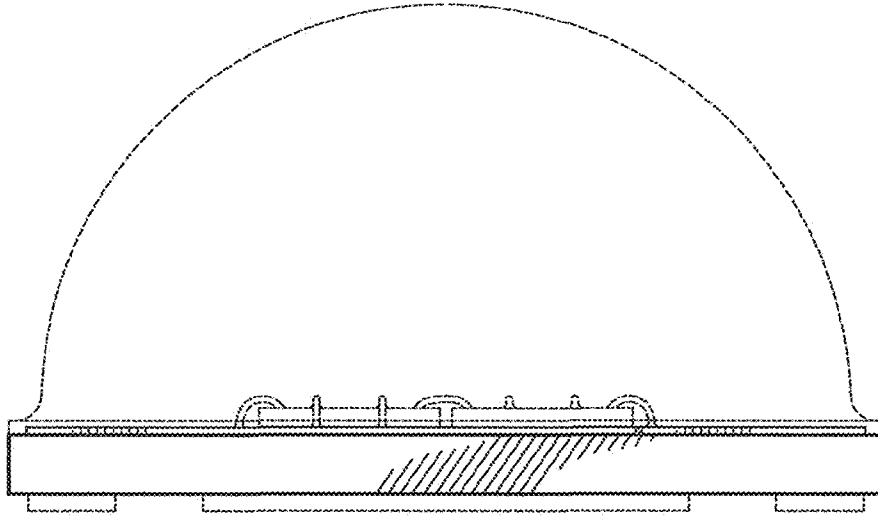

FIG. 13

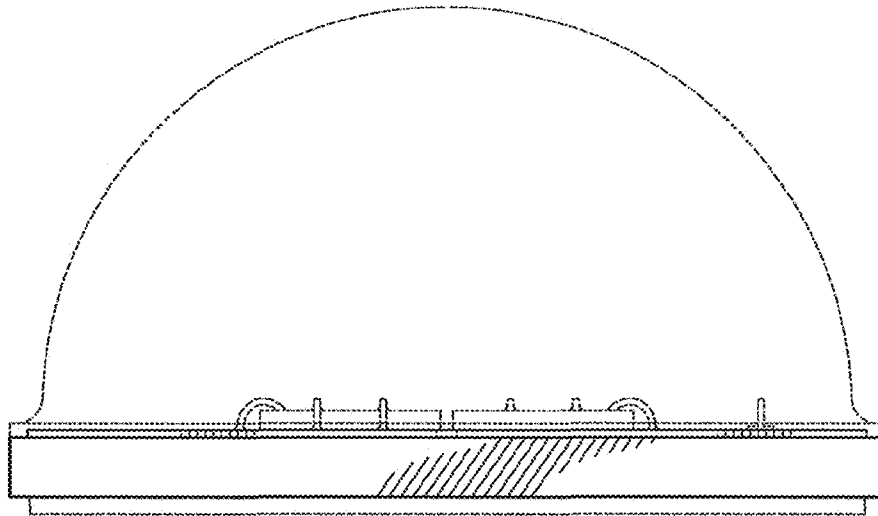

FIG. 14

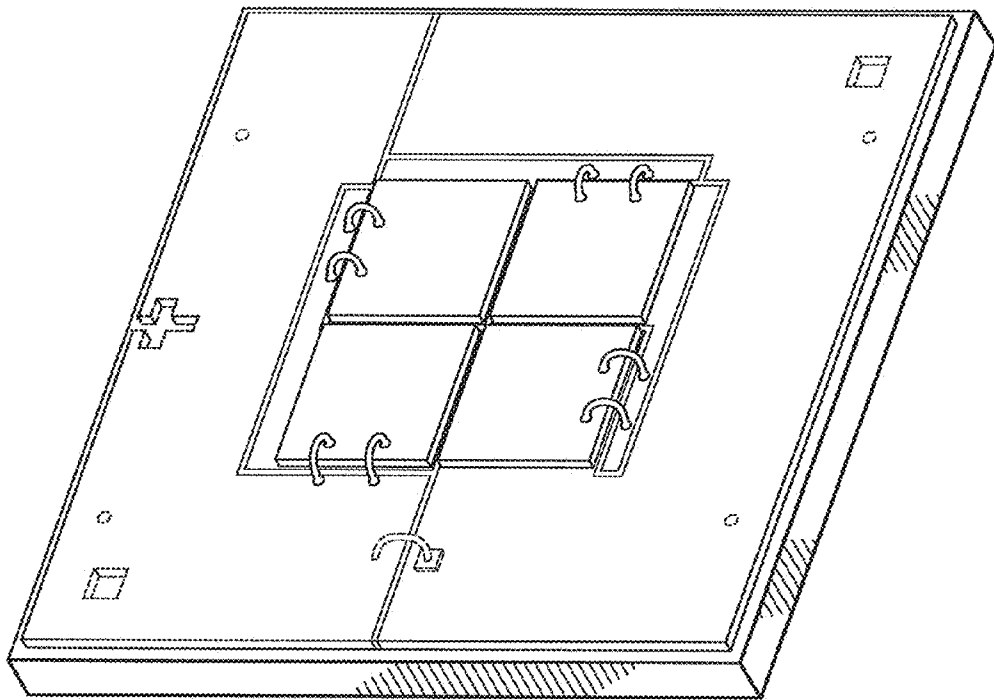

FIG. 15

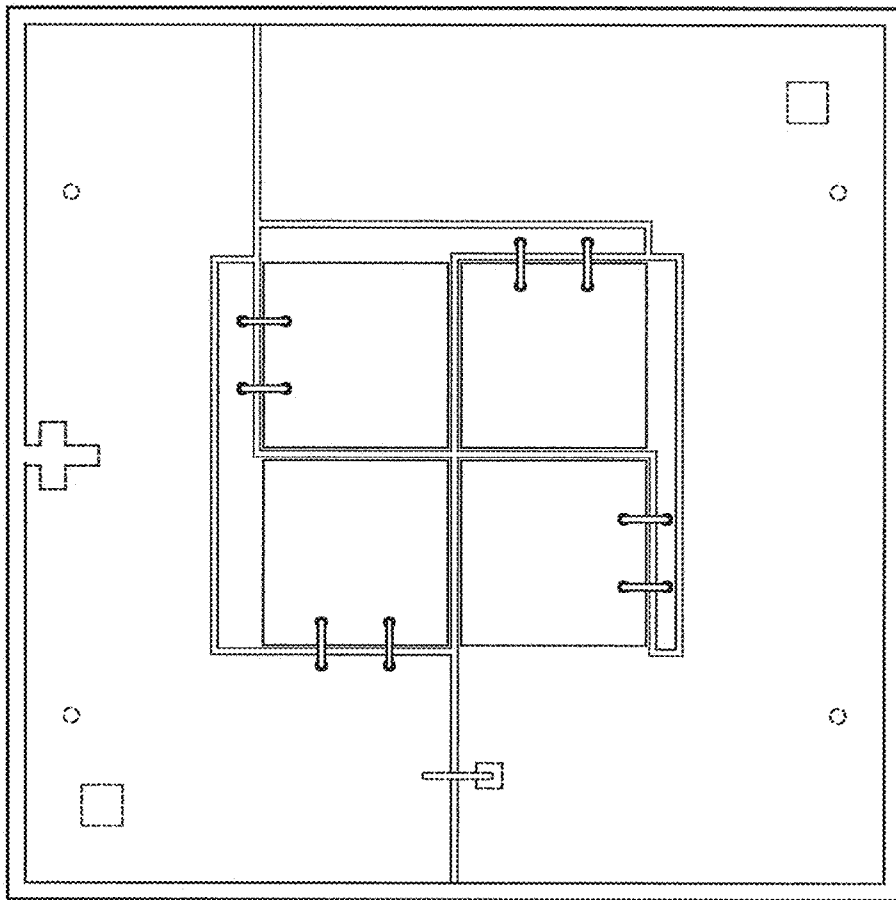

FIG. 16

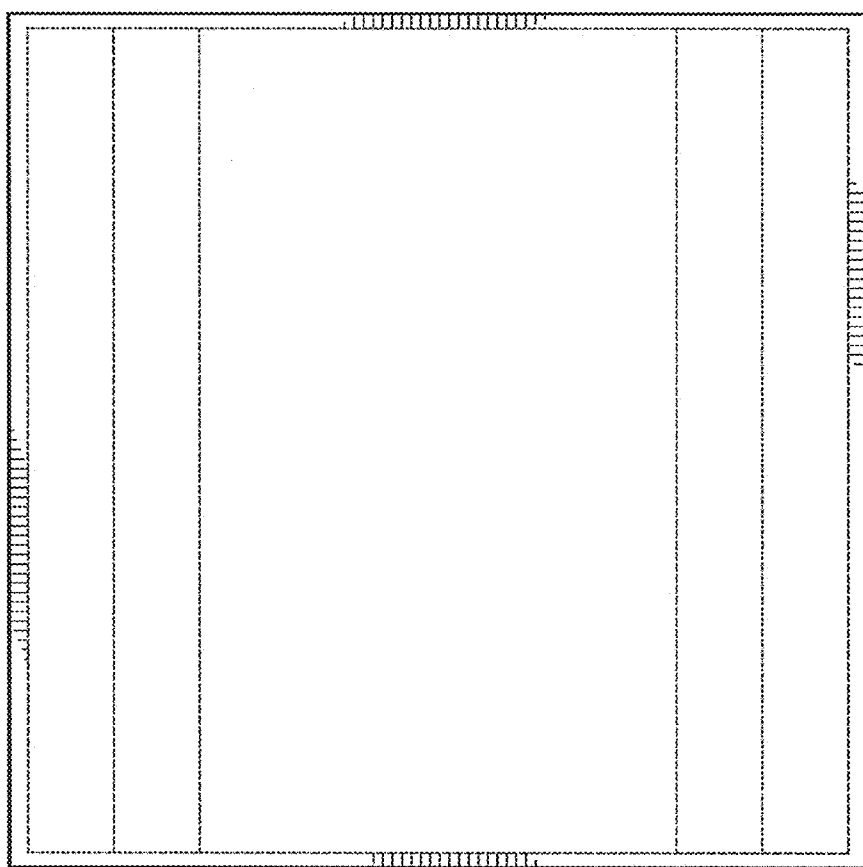

FIG. 17

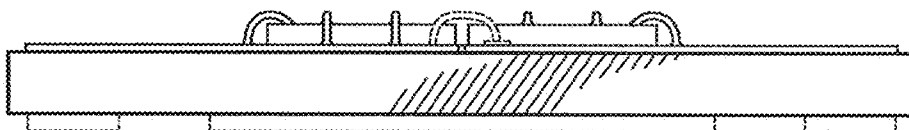

FIG. 18

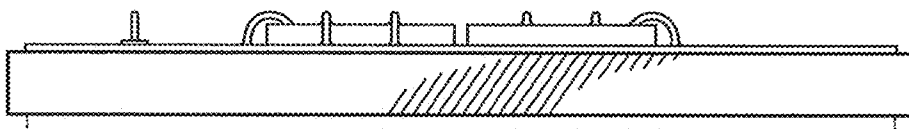

FIG. 19



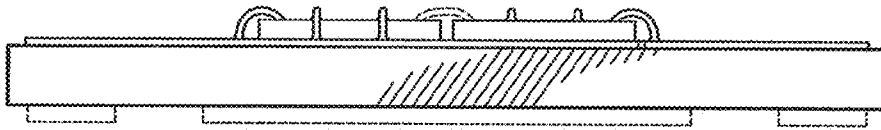

FIG. 20

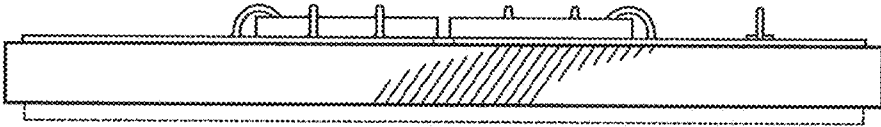

FIG. 21

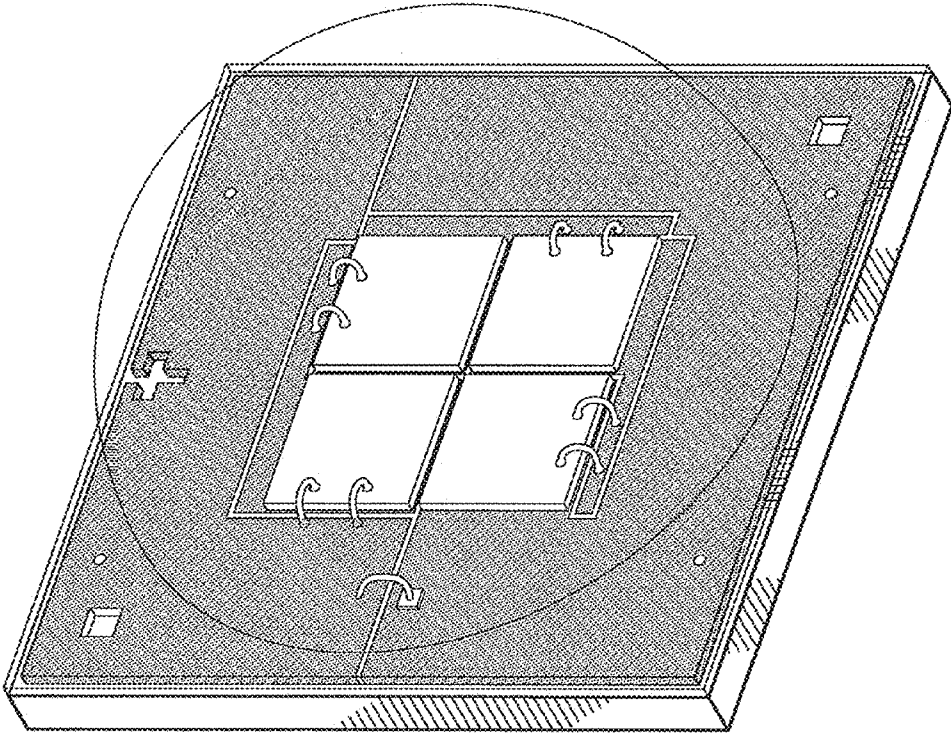

FIG. 22

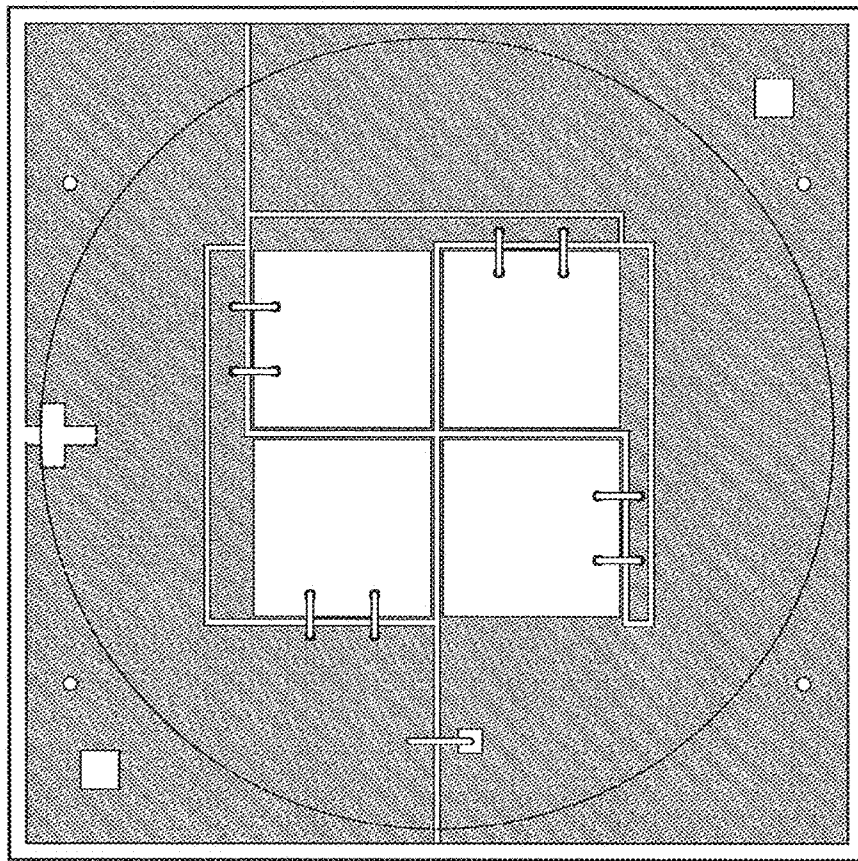

FIG. 23

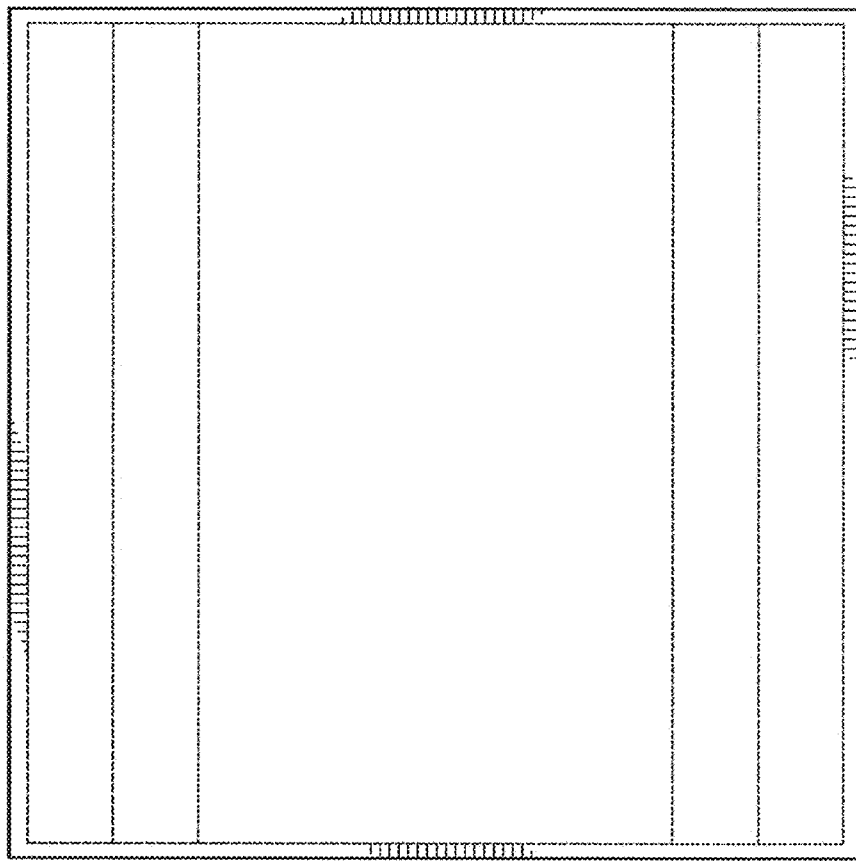

FIG. 24

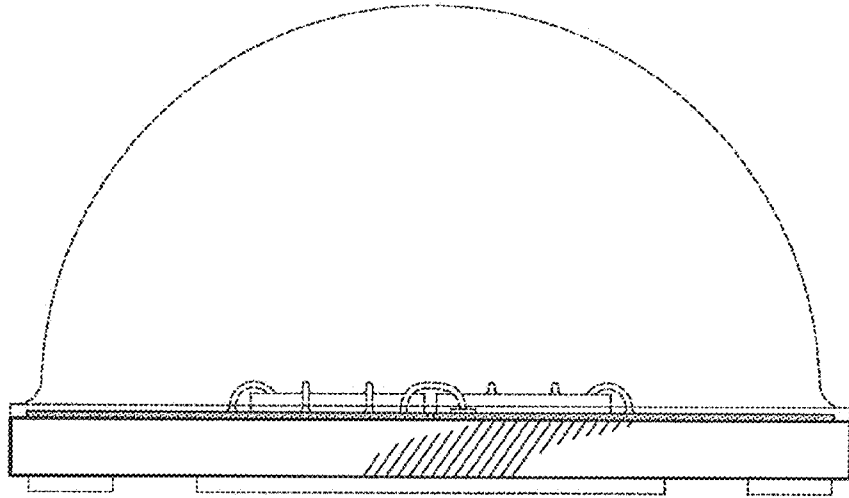

FIG. 25

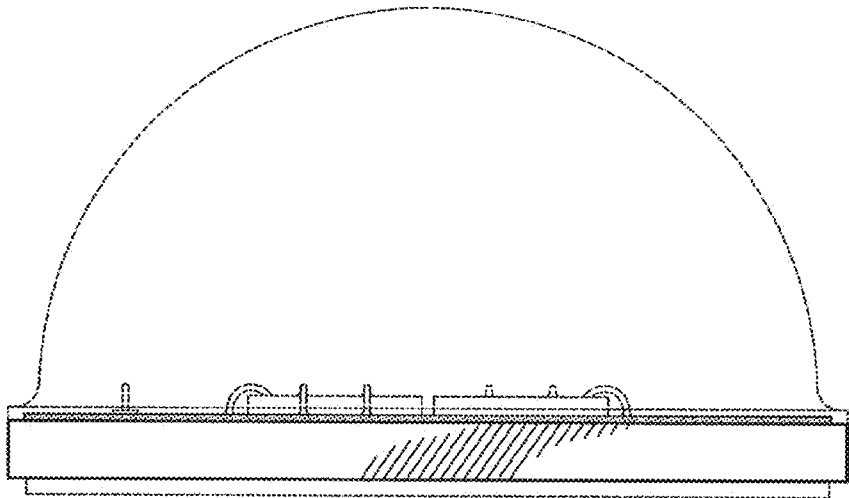

FIG. 26

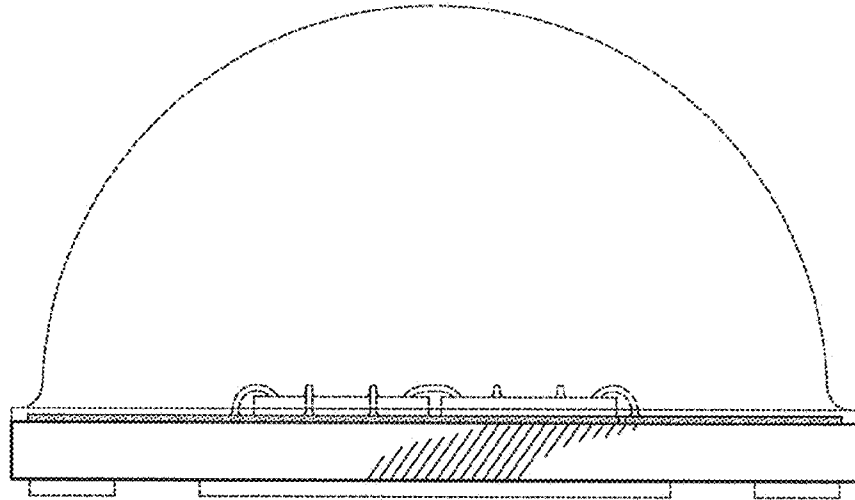

FIG. 27

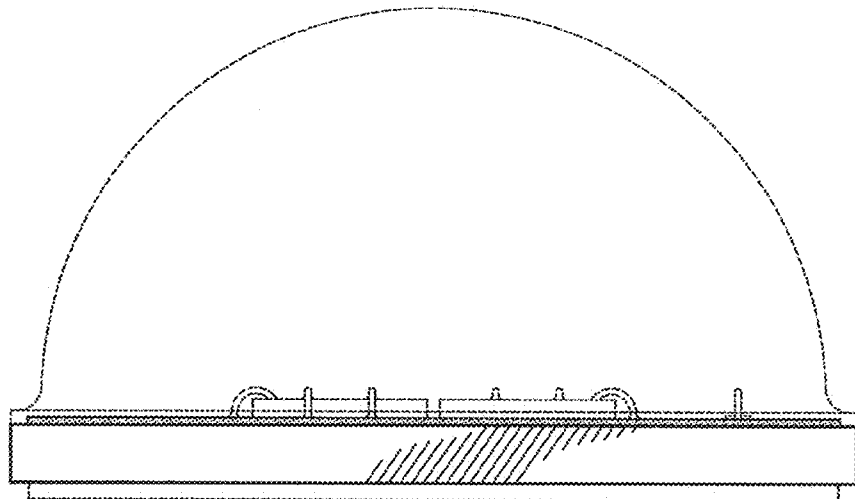

FIG. 28