

(19) World Intellectual Property Organization  
International Bureau



(43) International Publication Date  
27 April 2006 (27.04.2006)

PCT

(10) International Publication Number  
**WO 2006/044130 A1**

(51) International Patent Classification: <sup>7</sup> H04B 7/185

(74) Agent: BOLLMAN, William, H.; Manelli Denison & Seller PLLC, 7th Floor, 2000 M Street, NW, Washington, DC 20036 (US).

(21) International Application Number:  
PCT/US2005/034673

(81) Designated States (unless otherwise indicated, for every kind of national protection available): AE, AG, AL, AM, AT, AU, AZ, BA, BB, BG, BR, BW, BY, BZ, CA, CH, CN, CO, CR, CU, CZ, DE, DK, DM, DZ, EC, EE, EG, ES, FI, GB, GD, GE, GH, GM, HR, HU, ID, IL, IN, IS, JP, KE, KG, KM, KP, KR, KZ, LC, LK, LR, LS, LT, LU, LV, LY, MA, MD, MG, MK, MN, MW, MX, MZ, NA, NG, NI, NO, NZ, OM, PG, PH, PL, PT, RO, RU, SC, SD, SE, SG, SK, SL, SM, SY, TJ, TM, TN, TR, TT, TZ, UA, UG, US, UZ, VC, VN, YU, ZA, ZM, ZW.

(22) International Filing Date:  
29 September 2005 (29.09.2005)

(25) Filing Language: English

(26) Publication Language: English

(30) Priority Data:  
60/618,606 15 October 2004 (15.10.2004) US  
11/080,537 16 March 2005 (16.03.2005) US

(84) Designated States (unless otherwise indicated, for every kind of regional protection available): ARIPO (BW, GH, GM, KE, LS, MW, MZ, NA, SD, SL, SZ, TZ, UG, ZM, ZW), Eurasian (AM, AZ, BY, KG, KZ, MD, RU, TJ, TM), European (AT, BE, BG, CH, CY, CZ, DE, DK, EE, ES, FI, FR, GB, GR, HU, IE, IS, IT, LT, LU, LV, MC, NL, PL, PT, RO, SE, SI, SK, TR), OAPI (BF, BJ, CF, CG, CI, CM, GA, GN, GQ, GW, ML, MR, NE, SN, TD, TG).

(71) Applicant (for all designated States except US):  
TELECOMMUNICATION SYSTEMS, INC. [US/US];  
275 West Street, Suite 400, Annapolis, MD 21401 (US).

(72) Inventors: PITT, Lance, Douglas; 12014 SE 223rd Drive, Kent, WA 98013 (US). LAMPRECHT, Leslie, Johann; 3201 46th Avenue, SW, Seattle, WA 98116 (US). MARTIN, Jeffrey, Thomas; 8315 26th Avenue, NW, Seattle, WA 98117 (US).

Published:  
— with international search report

[Continued on next page]

(54) Title: LOCATING SATELLITES THROUGH IMPROVED CULLED SATELLITE EPHEMERIS INFORMATION

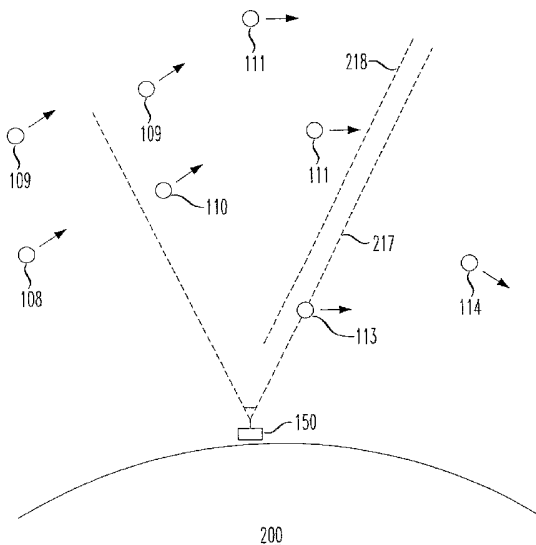

(57) Abstract: Locating satellites (e.g., GPS) are culled into a sub-plurality based largely on dwell time within an inverted cone above a relevant site in communication with a wireless device. A first inverted cone having a first base angle is defined above a first site, a second inverted cone having a second base angle is defined above a second site. If the second site is farther from an equator of Earth than the first site, then the second inverted cone is made to have a base angle larger than a base angle of the first inverted cone. If the first site is farther from the equator of Earth than the second site, then the first inverted cone is made to have a base angle larger than a base angle of the second inverted cone. The span of the inverted cone over the site closest to the equator may be limited.

WO 2006/044130 A1



---

*For two-letter codes and other abbreviations, refer to the "Guidance Notes on Codes and Abbreviations" appearing at the beginning of each regular issue of the PCT Gazette.*

## LOCATING SATELLITES THROUGH IMPROVED CULLED SATELLITE EPHEMERIS INFORMATION

5                    This application claims priority from U.S. Provisional Application 60/618,606, filed October 15, 2004; and from U.S. Application No. 11/080,537, filed March 16, 2005, the entirety of both are expressly incorporated herein by reference.

### 10                    **BACKGROUND OF THE INVENTION**

#### **1. Field of the Invention**

                    This invention relates generally to wireless and long distance carriers, Internet service providers (ISPs), and information content delivery services/providers and long distance carriers. More particularly, it relates  
15 to location services for the wireless industry.

#### **2. Background of Related Art**

                    It is desired to accurately locate cell phones within a cellular network. While there are several techniques for determining location in a  
20 mobile device, a future generation of mobile phones may include a global positioning satellite (GPS) receiver chipset, thus having the ability to locate itself via GPS.

                    Fig. 10 depicts the conventional Global Positioning Satellite system including about 24 or more GPS satellites.

25                    In particular, as shown in Fig. 10, the earth **200** is surrounded by approximately 24 GPS satellites **101-124**, which each have their own rotational orbit about the earth **200**. There are currently about 24 to 27 GPS satellites in the GPS network, each moving about the earth approximately 6 times each day.

30                    Unfortunately, as the phone moves about the country, locations with respect to satellites change. Thus, GPS devices attempting to determine their position with respect to the earth **200** will only be able to

communicate with a smaller number of the total GPS satellites at any one time.

The time required for lock in and location determination by a conventional GPS receiver in determining which of the GPS satellites in the GPS network takes several minutes, and as many as 5 or 6 minutes for a standard GPS receiver, which is longer than many if not most phone calls.

There is a need for a less cumbersome and more efficient technique for using GPS location information in a highly mobile and fast paced society.

### SUMMARY OF THE INVENTION

In accordance with the principles of the present invention, a plurality of locating satellites are culled into a sub-plurality for communication by a plurality of wireless devices. A first inverted cone is defined above a first site, the first inverted cone having a first base angle. A second inverted cone is defined above a second site, the second inverted cone having a second base angle. If the second site is farther from an equator of Earth than the first site, then the second inverted cone is made to have a base angle larger than a base angle of the first inverted cone. If the first site is farther from the equator of Earth than the second site, then the first inverted cone is made to have a base angle larger than a base angle of the second inverted cone.

Any sites used as reference points other than the first or second will have inverted cones defined above them with base angles greater than, equal to, or less than the inverted cones above the first and second sites depending on whether those other reference points are farther from the equator, at the same distance from the equator, or closer to the equator than either the first or second site.

30

### BRIEF DESCRIPTION OF THE DRAWINGS

Features and advantages of the present invention will become apparent to those skilled in the art from the following description with reference to the drawings, in which:

5                    Fig. 1 shows a base station of a wireless network (e.g., a cellular telephone network) determining which GPS satellites are in a preferred group, e.g., being within a cone of space with the longest dwell time within that space, in accordance with the principles of the present invention.

10                   Fig. 2 shows a top view of the cone of space as shown in Fig. 1.

                    Fig. 3 shows vector calculations for each GPS satellite, or for each of a preferred set of GPS satellites (e.g., those visible to the base station), in accordance with the principles of the present invention.

15                   Fig. 4 shows an exemplary culled GPS satellite table, in accordance with the principles of the present invention.

                    Fig. 5 shows an alternate exemplary culled GPS satellite information table, in accordance with the principles of the present invention.

20                   Figs. 6A and 6B show use of the calculation of an ellipsoid arc path actually traveled by each satellite to determine more accurately the length of time a locating satellite is within range of a particular location, in accordance with another embodiment of the present invention.

                    Figs. 7A, 7B(1) and 7B(2) show adjustment of the  
25 computation of the arc that defines the inverted cone encompassing culled satellites as a function of latitude, or distance from the equator, in accordance with yet another embodiment of the present invention.

                    Fig. 8 shows the utilization of wireless communication system cell sites as reference points, in accordance with a further  
30 embodiment of the present invention.

Fig. 9A(1) shows an exemplary culled locating satellite table including primary and secondary satellites, in accordance with an aspect of the present invention.

Fig. 9A(2) shows an alternative method of culling satellites by assigning a priority to each satellite within a given inverted cone, based on a remaining dwell time within the inverted cone, in accordance with another aspect of the present invention.

Fig. 9B shows an alternate exemplary culled locating satellite information table including visible, culled primary and secondary, and culled preferred (i.e., primary) locating satellites (e.g., GPS satellites), in accordance with yet another aspect of the present invention.

Fig. 10 depicts the conventional Global Positioning Satellite system including about 24 or more GPS satellites.

## 15 DETAILED DESCRIPTION OF ILLUSTRATIVE EMBODIMENTS

In a conventional GPS system, ephemeris data is provided to each GPS receiver to keep track of where each of the satellites in the GPS satellite network should be located in space. As part of the location determination process, each GPS receiver determines which of approximately 24 or more GPS satellites are to be used to determine GPS location. This determination requires a significant amount of real-time processing at the time of the location request, and a significant amount of time.

Fig. 1 shows a base station 150 of a wireless network (e.g., a cellular telephone network) determining which GPS satellites 101-124 are in a preferred group, e.g., being within a cone of space 217 with the longest dwell time within that space, in accordance with the principles of the present invention.

In particular, as shown in Fig. 1, of the twenty four or so GPS satellites 101-124 in the GPS system, only a sub-set 107-114 are visible to the base station 150 at any one time. Thus, based on

ephemeris data, the satellites communicating with a subscriber or user within a service range of the base station **150** may be culled to only those visible, e.g., GPS satellites **107-114**.

As a further culling, only those GPS satellites **109-113** currently within a cone of space **217** above the relevant base station **150** might be selected for communication with a receiver or subscriber within the service area of the relevant base station **150**.

As an ultimate culling, a minimum set of GPS satellites **109-112** may be selected based on, e.g., being not only within an arbitrary cone of space **217** normal to the base station **150**, but also projected to remain within that cone of space **217** for the longest period of time, i.e., having the longest dwell time. Thus, GPS satellite **113** may be eliminated or culled from the minimum set of GPS satellites as it has almost completely passed through the cone of space **217**, and will have the shortest dwell time of all GPS satellites within the cone of space **217**.

Ideally, the cone of space **217** will be defined sufficiently large to contain at least four GPS satellites at any one time. Alternatively, if fewer than the minimum GPS satellites are within the cone of space **217**, then alternative selection criteria may be employed until sufficient number of GPS satellites enter the cone of space **217**. For instance, a GPS satellite being closest to the cone of space may be utilized.

Updated ephemeris data is typically transmitted for one GPS satellite each second. Thus, for a GPS network of, e.g., 24 satellites, updated ephemeris data for all GPS satellites will have been transmitted after 24 seconds. If the network is larger, e.g., 27 GPS satellites, all ephemeris data will be transmitted after 27 seconds. Preferably, the satellites will be periodically culled in accordance with the principles of the present invention based on the provision of updated ephemeris data, e.g., once every 24 seconds, once every 27 seconds, etc.

In accordance with the principles of the present invention, the total number of available GPS satellites **101-124** is centrally culled for

each service location, e.g., for each base station. The culling may be graduated, e.g., for each base station. The culling may be graduated, e.g., first down to those GPS satellites 107-114 that are visible, and then down to a preferred minimum group (e.g., four (4) GPS satellites) having the longest dwell time for use by the particular cell site, or the culling may be to some desired number of satellites all of which are annotated with an order of precedence indicator with which the mobile device can tell which is best, which is second best, etc. Of course, the culling may simply cull to a desired level (e.g., to a minimum of three or four GPS satellites within the cone of space and having the longest dwell time) without graduation or indication of precedence.

When needed, the selected GPS satellites for a particular region at any particular time of request will be passed to requesting mobile devices to help it determine its own location. For instance, each operative mobile unit is preferably periodically updated with a revised list of selected GPS satellites resulting from the culling of the GPS satellites, e.g., once after each new updated culled list of satellites is determined. The information provided to each subscriber upon request preferably contains the identity of those GPS satellites that are selected for communication. However, information provided in the reverse sense is also within the scope of the present invention (e.g., a list of GPS satellites NOT to communicate with).

A wireless network may generate a flush of updated culled GPS satellite information periodically, e.g., every 24 seconds. Note that based on the positions of the various GPS satellites 101-124, and in particular based on the positions of the selected GPS satellites 109-112 within the cone of space 217, the list of selected GPS satellites may or may not change.

Preferably, network traffic will be minimized by reducing or eliminating redundant GPS satellite information. Thus, in a preferred

embodiment, GPS satellite list updating messages are sent only when a change in the list has occurred.

Fig. 2 shows a top view of the cone of space **217** as shown in Fig. 1.

5 In particular, as shown in Fig. 2, a cone of space **217** is viewed from space normal to a base station **150**. On the ground, the base station **150** has a service region **151**. The circular representation of the cone represents a plane cut across the cone of space **217**.

10 Within the cone of space **217**, GPS satellites **101-124** generally travel from one side to the other. Dwell time is determined based on a distance between the present location of the particular GPS satellite, and the exit edge of the cone of space **217**, as well as the rate of speed of the GPS satellite.

15 A minimum dwell time may be defined and represented as an edge **218** shown in Figs. 1 and 2.

A satellite velocity vector may be determined or predetermined. Satellite velocity vector as used herein refers to a vector whose magnitude is the velocity of the satellite and whose origin is the satellite's current position.

20 The satellite's velocity vector may be derived from the ephemeris data describing the satellite's orbit and current position. The satellite's velocity vector provides the satellite's velocity and direction of travel. The satellite's velocity and direction are used to compute the point of intersection of the satellite's orbit and the edge of the cone of visibility **217**.

25 This computed point of intersection along the satellite's orbit defines the endpoint of an ellipsoid arc from the satellite's current position to the point of intersection. The satellite's velocity and orbital parameters provided by ephemeris data can be used to compute the time it will take the satellite to traverse that ellipsoid arc. This time value constitutes the **30** satellite's dwell time within the cone of visibility.

It should be noted that GPS satellites have many different orbits, and almost never travel in precisely the same direction as other GPS satellites, as depicted by the various directions of the velocity vectors shown in Fig. 2.

5                   In accordance with the principles of the present invention, a small group of GPS satellites with the longest "cone" dwell times will be selected and some of the other GPS satellites will be "culled". The longest dwell time relates to the amount of time that a calculated GPS satellite vector will be within a respective cone of space **217** above a  
10 particular region of users, e.g., above a particular base station **150**.

The cone of space **217** may be simply a cone of visibility above the base station **150**, or may be more narrowly defined than visibility.

The resultant list of selected GPS satellites is preferably  
15 periodically and continually updated for any particular location, e.g., base station **150**, as the GPS satellites **101-124** rotate about the earth. Updated selected GPS satellite lists are preferably communicated to the subscriber's mobile device (or other suitable application location) for their respective calculations of accurate location information. With the use of  
20 selected GPS satellites only by culling out unnecessary or unseen GPS satellites, the total time required for a mobile phone to locate itself can be reduced significantly, e.g., from minutes to just seconds.

Fig. 3 shows vector calculations for each GPS satellite **101-124**, or for each of a preferred set of GPS satellites (e.g., those visible to  
25 the base station), in accordance with the principles of the present invention.

In particular, as shown in Fig. 3, conventional GPS ephemeris data is formatted as RINEX 2.10 data, which is provided by conventional GPS ephemeris data vendors to a Gateway Mobile Location  
30 Center (GMLC) and/or mobile position center (MPC). In the preferred embodiment, a Xypoint Location Platform (XLP) was used. In accordance

with the principles of the present invention, received RINEX data is converted into an Earth Center (EC) position vector (i.e., a vector pointing to the satellite's current position whose origin is the center of the Earth). Then, using the Earth Center position vectors, the available GPS satellites  
5 are culled such that only desired GPS satellites are communicated with (i.e., those that will be in the cone of space **217** the longest).

In the disclosed embodiments, an Earth Center position vector is computed (or pre-computed) for every cell site **150** in a cellular network. The cell site's EC position vector can be subtracted from the  
10 GPS satellite's EC position vector to arrive at a vector that points from the cell site **150** to the particular GPS satellite **101-124**. The resulting vector can be divided by its own magnitude to generate a unit vector that points from cell site **150** toward the particular GPS satellite **101-124**. The cell site's EC position vector can similarly be divided by its own magnitude to  
15 generate a unit vector that points straight up from the cell site **150** (also pre-computed).

The dot product of the GPS satellite pointing unit vector and the vertical unit vector yields the cosine of the angle between the two vectors. The cosine of an angle of zero degrees yields the value 1.0. The  
20 resulting value of the equation "cosine (angle)" diminishes as the angle grows until the cosine of 90 degrees yields the value 0.0. The cosine of angles greater than 90 degrees yield negative results. This makes the cosine of the angle between the satellite pointing unit vector and the vertical unit vector particularly well suited for identifying whether or not the  
25 satellite is "visible". An angular measurement defining a cone of space above the cell site (e.g., a "cone of visibility") can be pre-computed as a function of the latitude at which the cell site is located. The cosine of this latitude derived angle can be saved. Any satellite whose dot product with the vertical unit vector yields a value greater than or equal to the saved  
30 cosine reference value can then be considered "visible".

Thus, a rough culling of GPS satellites **101-124**, e.g., to only those visible, or even better yet to only those most normal to a base station **150**, certainly culling out all GPS satellites that aren't visible at all, and reducing the number of GPS satellites with which to communicate to some small number, each of which is annotated with its order of precedence. This helps keep the time needed to determine location short by providing "backup" satellites with which to communicate just in case local topography blocks the signal from a satellite with a longer dwell time (e.g., a satellite with a lower "order of precedence" value).

Fig. 4 shows an exemplary culled GPS satellite table **100**, in accordance with the principles of the present invention.

In particular, as shown in Fig. 4, the selected group of satellites for any particular cell site may be maintained in a suitable database and/or other table **100**, which may then be provided upon request to any particular mobile device within the service area of that particular cell site **150**.

Thus, a small subgroup of GPS satellites having the longest dwell time with respect to a servicing cell site **150** are selected, and maintained in a culled satellite table **100** communicated to all active mobile subscribers (or other grouping of mobile users). Moreover, or alternatively, whenever a mobile device requires ephemeris data, it may request an update to a culled satellite table **100** containing the identity of the preferred satellites with which to use to determine location of the mobile device.

Fig. 5 shows an alternate example of a selected or culled GPS satellite information table, in accordance with the principles of the present invention.

In particular, as shown in Fig. 5, a database or table **100b** may include information regarding all or most GPS satellites **101-124**, with those that are selected for any particular base station **150** being appropriately indicated.

While the present invention is explained with reference to the use of as few as three (3) or four (4) and as many as 24 or 27 available satellites **101-124**, the present invention relates to the use of any number less than all GPS satellites.

5                   Moreover, while the present invention provides culling of visible satellites, and even to a minimum number of satellites, e.g., down to four from those visible satellites, the resultant number of satellites may be a number greater than or even less than 4, within the principles of the present invention. For instance, if only position is required, only three (3)  
10 GPS satellites are required. However, if altitude is also required, four (4) GPS satellites are the minimum required and thus the maximum culling level. Moreover, the use of more than approximately six (6) GPS satellites do not significantly improve the accuracy of the results.

15                   If a mobile device is unable for some reason to communicate with one or more GPS satellites directed by the culled GPS satellite table or similar information, the mobile device may then attempt to achieve location information in an otherwise conventional manner, e.g., by attempting contact with all GPS satellites.

20                   The core technology of culling locating satellites to a plurality is disclosed in U.S. Patent No. 6,650,288, co-owned with the present application. The following sets forth several significant advances to that core technology.

1) Compute satellite dwell time based on ellipsoid arc

25                   Figs. 6A and 6B show use of the calculation of an ellipsoid arc path actually traveled by each satellite to determine more accurately the length of time a locating satellite is within range of a particular location, in accordance with another embodiment of the present invention.

30                   In particular, as described above, a satellite's path may be projected onto a plane that, cutting through the inverted cone over a reference point, forms a circle. As described, the satellite's speed could

be used to approximate the satellite's dwell time within the cone. This is a simple function of computing the amount of time it would take the satellite to traverse the chord cutting across the circle as if it were actually traveling in a straight line.

5                   However, a straight line in the plane cutting across the inverted cone would be an approximation. The satellite isn't actually traveling in a straight line, but rather in an ellipsoid arc.

                  In accordance with this embodiment, the dwell time is computed using the satellite's actual ellipsoid arc, as well as the position  
10                   of the satellite with respect to the Earth (i.e., whether the satellite's altitude is increasing or decreasing) to improve the selection process.

                  As shown in Fig. 6A, the orbit of a locating satellite is typically elliptical. The depiction in Fig. 6A is somewhat exaggerated in ellipticity for ease of explanation. In the orbit, the point(s) at which the  
15                   locating satellite is farthest from Earth is called the apogee of the orbit, while the point(s) at which the locating satellite is closest to the Earth is called the perigee of the orbit.

                  The present embodiment appreciates two aspects of the calculation of satellite dwell time that are not detailed in the prior art: the  
20                   ellipsoid arc path of the locating satellite through the inverted cone (as depicted in Fig. 6B), and the fact that the acceleration of the locating satellite is decreasing as it moves on its orbit beyond perigee but toward apogee, causing a decrease in the speed of the locating satellite with respect to the Earth. As the locating satellite moves in its orbit between  
25                   apogee and perigee, the gravitational pull of the Earth causes an increasing acceleration, and thus an increasing speed.

                  The math involved in calculating the ellipsoid arc passing through any given cross section of any given inverted cone (e.g., as shown in Fig. 6B) is conventional, as is calculations of the acceleration  
30                   and speed of the locating satellite on any given point of its orbit. It is the recognition and application of the actual path of the locating satellite as

well as its actual speed, rather than use of a straight line approximation, that is important to the principles of the present embodiment of the invention.

5 2) Compute the arc that defines the inverted cone as a function of latitude

Figs. 7A, 7B(1) and 7B(2) show adjustment of the computation of the arc that defines the inverted cone encompassing culled satellites as a function of latitude, or distance from the equator, in accordance with yet another embodiment of the present invention.

10 In particular, as described above, an angle may be defined that ultimately defines a cone above the reference point. In accordance with yet another embodiment, that angle defining the cone may be selected or computed as a function of the reference point's latitude.

Fig. 7A depicts a cross-sectional view of Earth, with an imaginary base station 707 located longitudinally on the equator. The angle A at the base of the inverted cone defining locating satellites within view is at a minimum.

The present embodiment establishes inverted cones with a larger angle (B and C, respectively) as compared to the angle A of the inverted cone at the equator. In this embodiment, the larger angles B, C of the inverted cones are established to be in a relationship to the latitude (e.g., the distance from the equator of the Earth) of the relevant base station.

Thus, the closer the relevant base station is to the equator, the more likely it is that a sufficient number of locating satellites will be visible (e.g., 4 satellites visible). The farther the relevant base station is from the equator, the fewer number of locating satellites would be visible within a same inverted cone.

Stated differently, the present embodiment establishes an inverted cone having a larger base angle at a base station farther from the equator to encompass the same number of preferred or minimum culled

locating satellites as would a base station located more closely to the equator. This is depicted in Figs. 7B(1) and 7B(2).

In particular, Fig. 7B(1) shows a cross section of the inverted cone established to define the culling of locating satellites for a base station **707**. The base angle of the inverted cone has an angle A.

In comparison, as shown in Fig. 7B(2), a cross section of the inverted cone established to define the culling of locating satellites for a base station **708** located farther from the equator than was base station **707** shown in Fig. 7B(1). As depicted, at or near the equator the distribution of satellites within the cone of visibility will likely be fairly uniform. However, in locations significantly away from the equator, the distribution of visible satellites within the cone of visibility look tend to be nearer to one boundary or the other, depending on which hemisphere), rather than being uniformly distributed throughout the inverted cone. Thus, as shown in Fig. 7B(2), in a location away from the equator, the visible satellites tend to favor the edge of the inverted cone closest to the equator.

The present embodiment also appreciates that received signal strength from the locating satellites is best when the locating satellite is directly overhead of the base station (i.e., normal to the Earth at the location of the base station). Thus, the inverted cone of 'visible' locating satellites is made narrower when the base station is closer to the equator of the Earth, and made larger when the base station is farther from the equator of the Earth.

Thus, as appreciated by the present inventors, there are benefits to limiting the span of the inverted cone if one's latitude doesn't force a wider span just to see the GPS satellites.

### 3) Utilization of Cell Site Antennas as Reference Points

The embodiments thus far relate to the definition of a full inverted cone above a base station **150** (e.g., having 360 degree

coverage). Fig. 8 shows the utilization of reference points for locating satellites, in accordance with a further embodiment of the present invention.

In particular, an inverted cone **217** is computed above given  
5 'reference points' as an estimate for an inverted cone above the relevant wireless device **150**. In accordance with a further embodiment, the reference point may be a wireless communications cell site **860** (e.g., cell phone base station antennas). Thus, cell sites **860** may be specifically used as reference points for culling the ephemeris information used to  
10 expedite Assisted GPS location determinations.

In order to enable the mobile handsets (i.e., cell phones, wireless enabled PDAs, etc.) to quickly locate themselves, it is desired to provide them with a good indication of with which satellites to communicate.

15 To give the handset the subset of satellites it should communicate with, a rough idea as to the location of all satellites is required. Such a rough idea allows the choice of a subset of the satellites that have a very high probability of being visible to the handset.

The parent patent (USP 6,650,288) refers to the "rough" or  
20 "approximate" positions as "reference points". However, in accordance with this aspect of the invention, it is possible to use any point at all, as long as one is chosen that is easily and quickly picked, and that is also fairly close to the mobile handset.

Cell sites are particularly well suited for use as reference  
25 points for cellular phones because every mobile handset must communicate with a cell site in order to do even basic wireless functions, and all the cell sites have been surveyed such that their locations are known. Surveying the cell sites was necessary in the U.S. in order to provide Phase One (i.e. imprecise) location for enhanced 911 support so  
30 that data is readily available. Though Asia's and Europe's Emergency

Services mandates are different than that of the United States, the cell sites in those areas are also surveyed so their locations are also available.

Since cellular phones connect to carrier's networks through cell sites, there is very little additional time necessary to use that cell site's location as a rough approximation of the handset's location for the purposes of choosing a subset of locating satellites.

In some cases, a cell site may have several sectors but be represented by only one location. In other cases, a cell site may represent only one receiver of a collection of receivers (see Fig. 8). In either case, the mobile handset will be communicating with one and only one of the cell sites, and that cell site will have a surveyed location that will quite nicely approximate the handset's location for the purposes of selecting a subset of locating satellites.

4) Provide more than four (4) satellite's ephemeris data with an order of precedence indication

As described above, it is preferred that no more than four (4) satellite's ephemeris data would be delivered to a wireless handset. In this way, using too much Radio Frequency (RF) bandwidth is avoided, while providing the data necessary to achieve a good GPS fix for latitude, longitude, and altitude too.

Sometimes, more than just four (4) satellite's data is sent to the handset. Sometimes this is done so that the handset can perform its own satellite selection. Sometimes this is done to provide a fallback in case a particular handset is masked and cannot receive the signal of one or more of the primary selections.

Figs. 9A(1), 9A(2) and 9B show the use of more than 4 culled satellites, providing the identities of additional satellites for the wireless device to use as backup satellites as necessary (e.g., when a culled, preferred satellite is masked and the wireless device cannot receive the signal of that primary selection), in accordance with still another embodiment of the present invention. Thus, a number 'N' ('N'

being greater than 1 or 2 or 4 or whatever) of locating satellite's ephemeris data may be used, along with a preferred 'order of precedence', allowing a mobile device to use the desired minimum number of locating satellites (e.g., four (4) locating satellites) if available, but could fall back as necessary to the use of other locating satellites that are visible but still favorable.

Fig. 9A(1) shows an exemplary culled locating satellite table including a list of a preferred number of primary satellites (e.g., 4 preferred satellites). Additionally, the exemplary culled locating satellite table includes an identification of at least one or more secondary locating satellites.

Preferably, a priority is given to each of the secondary locating satellites such that the relevant mobile device will, as necessary, attempt to receive a signal from each of the secondary locating satellites in the prioritized order.

The mobile device may, depending upon the particular application, attempt contact with all secondary, tertiary, etc. locating satellites listed in the culled locating satellites table 100c. However, it is more preferable, to save network resources and time, that once a sufficient number of locating satellites have been achieved, the need to contact additional locating satellites becomes unnecessary and may be abandoned for that particular locating session.

Fig. 9A(2) shows an alternative method of culling satellites by assigning a priority to each satellite within a given single inverted cone, based on a remaining dwell time within the inverted cone, in accordance with another aspect of the present invention.

In particular, all dwell times are simply computed (i.e., durations within the inverted cone of visibility defined over a particular reference point), and then pick 'N' number of satellites. The number of satellites picked may be, e.g., five, or six, or nine, or twelve, or whatever,

so long as there are more satellites picked than are necessary to determine location as desired.

These 'N' satellites are then annotated with an integer precedence value. The satellite with the longest dwell time would be annotated with a precedence value of '1'. The satellite with the second longest dwell time would be annotated with a precedence value of '2'. This would give the mobile handsets an easy indication as to which satellites to limit their position determination, and which satellites to attempt to utilize first, second, third, etc.

The assignment of precedence to satellites allows a mobile handset a viable fallback should one of the preferred four (4) satellites be temporarily obscured while attempting to determine the handset's location. In this case, the handset would timeout while attempting to receive one (or more) of the preferred satellites' signal, and simply move to the satellite in the list with the next lowest precedence indicator.

Fig. 9B shows an alternate exemplary culled locating satellite information table including visible, culled primary and secondary, and culled preferred (i.e., primary) GPS satellites, in accordance with yet another aspect of the present invention. Thus, a complete picture of all locating satellites that the relevant mobile device may possibly receive a locating signal from is provided to the mobile device, allowing the mobile device itself decide which locating satellites are to be communicated with, and in what order.

While the invention has been described with reference to the exemplary embodiments thereof, those skilled in the art will be able to make various modifications to the described embodiments of the invention without departing from the true spirit and scope of the invention.

**CLAIMS**

What is claimed is:

1. A method of culling a plurality of locating satellites into a sub-plurality for communication by a plurality of wireless devices,  
5 comprising:

defining a first inverted cone above a first site, said first inverted cone having a first base angle; and

defining a second inverted cone above a second site, said second inverted cone having a second base angle;

10 wherein if said second site is farther from an equator of Earth than said first site, then said second inverted cone is made to have a base angle larger than a base angle of said first inverted cone; and

if said first site is farther from said equator of Earth than said second site, then said first inverted cone is made to have a base angle  
15 larger than a base angle of said second inverted cone.

2. The method of culling a plurality of locating satellites into a sub-plurality for communication by a plurality of wireless devices according to claim 1, further comprising:

20 calculating an ellipsoid arc path of each of said plurality of locating satellites within said first inverted cone at a given time; and

calculating an ellipsoid arc path of each of said plurality of locating satellites within said second inverted cone at said given time.

25 3. The method of culling a plurality of locating satellites into a sub-plurality for communication by a plurality of wireless devices according to claim 1, further comprising:

calculating a distance of each of said ellipsoid arc paths within said first inverted cone; and

30 calculating a distance of each of said ellipsoid arc paths within said second inverted cone.

4. The method of culling a plurality of locating satellites into a sub-plurality for communication by a plurality of wireless devices according to claim 2, further comprising:

5                    calculating a time for each of said plurality of locating satellites to traverse said calculated distance within said first inverted cone; and

                      calculating a time for each of said plurality of locating satellites to traverse said calculated distance within said second inverted  
10 cone.

5. The method of culling a plurality of locating satellites to a sub-plurality for communication by a plurality of wireless devices according to claim 3, further comprising:

15                    determining a change in speed component of each of said plurality of locating satellites based on a point of a respective orbit of each of said plurality of locating satellites with respect to Earth.

6. The method of culling a plurality of locating satellites into a sub-plurality for communication by a plurality of wireless devices according to claim 1, wherein:

                      said first inverted cone is defined by a first base station; and  
                      said second inverted cone is defined by a second base  
station.

25

7. The method of culling a plurality of locating satellites into a sub-plurality for communication by a plurality of wireless devices according to claim 1, wherein:

said first inverted cone is defined by a first wireless device;

5 and

said second inverted cone is defined by a second wireless device.

8. The method of culling a plurality of locating satellites into a sub-plurality for communication by a plurality of wireless devices according to claim 1, wherein said first wireless device and said second wireless device each comprise:

a cell phone.

9. The method of culling a plurality of locating satellites into a sub-plurality for communication by a plurality of wireless devices according to claim 1, wherein said plurality of locating satellites each comprise:

a Global Positioning Satellite (GPS).

20

10. The method of culling a plurality of locating satellites into a sub-plurality for communication by a plurality of wireless devices according to claim 1, further comprising:

25 defining a third inverted cone above a third site, said third inverted cone having a third base angle.

11. Apparatus for culling a plurality of locating satellites into a sub-plurality for communication by a plurality of wireless devices, comprising:

5 means for defining a first inverted cone above a first site, said first inverted cone having a first base angle; and

means for defining a second inverted cone above a second site, said second inverted cone having a second base angle;

10 wherein if said second site is farther from an equator of Earth than said first site, then said means for defining said second inverted cone defines said second inverted cone to have a base angle larger than a base angle of said first inverted cone; and

15 if said first site is farther from said equator of Earth than said second site, then said means for defining said first inverted cone defines said first inverted cone to have a base angle larger than a base angle of said second inverted cone.

12. The apparatus for culling a plurality of locating satellites into a sub-plurality for communication by a plurality of wireless devices according to claim 11, further comprising:

20 means for calculating an ellipsoid arc path of each of said plurality of locating satellites within said first inverted cone at a given time; and

25 means for calculating an ellipsoid arc path of each of said plurality of locating satellites within said second inverted cone at said given time.

13. The apparatus for culling a plurality of locating satellites into a sub-plurality for communication by a plurality of wireless devices according to claim 11, further comprising:

5 means for calculating a distance of each of said ellipsoid arc paths within said first inverted cone; and

means for calculating a distance of each of said ellipsoid arc paths within said second inverted cone.

14. The apparatus for culling a plurality of locating satellites into a sub-plurality for communication by a plurality of wireless devices according to claim 12, further comprising:

10 means for calculating a time for each of said plurality of locating satellites to traverse said calculated distance within said first inverted cone; and

15 means for calculating a time for each of said plurality of locating satellites to traverse said calculated distance within said second inverted cone.

15. The apparatus for culling a plurality of locating satellites to a sub-plurality for communication by a plurality of wireless devices according to claim 12, further comprising:

20 means for determining a change in speed component of each of said plurality of locating satellites based on a point of a respective orbit of each of said plurality of locating satellites with respect to Earth.

25

16. The apparatus for culling a plurality of locating satellites into a sub-plurality for communication by a plurality of wireless devices according to claim 11, wherein:

5       said means for defining a first inverted cone is comprised in a first base station; and

      said means for defining a second inverted cone is comprised in a second base station.

17. The apparatus for culling a plurality of locating satellites into a sub-plurality for communication by a plurality of wireless devices according to claim 11, wherein:

10       said means for defining a first inverted cone is comprised in a first wireless device; and

15       said means for defining a second inverted cone is comprised in a second wireless device.

18. The apparatus for culling a plurality of locating satellites into a sub-plurality for communication by a plurality of wireless devices according to claim 17, wherein said first wireless device and said second wireless device each comprise:

      a cell phone.

19. The apparatus for culling a plurality of locating satellites into a sub-plurality for communication by a plurality of wireless devices according to claim 17, wherein:

25       said first wireless device and said second wireless device each comprise GPS enabled mobile technology.

20. The apparatus for culling a plurality of locating satellites into a sub-plurality for communication by a plurality of wireless devices according to claim 17, wherein said first wireless device and said second wireless device each comprise:

5                   a wireless personal digital assistant (PDA).

21. The apparatus for culling a plurality of locating satellites into a sub-plurality for communication by a plurality of wireless devices according to claim 17, wherein said first wireless device and said second  
10 wireless device each comprise:

                  a location enabled laptop computer.

22. The apparatus for culling a plurality of locating satellites into a sub-plurality for communication by a plurality of wireless devices  
15 according to claim 11, wherein said plurality of locating satellites each comprise:

                  a Global Positioning Satellite (GPS).

20

FIG. 1

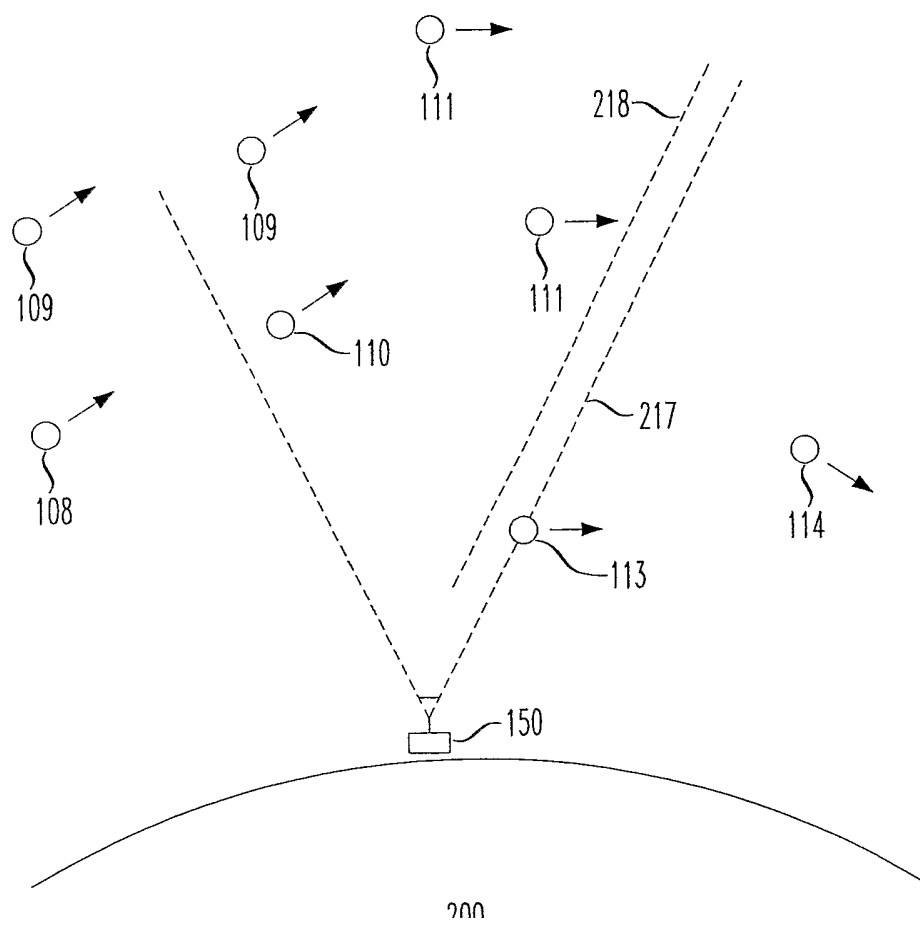
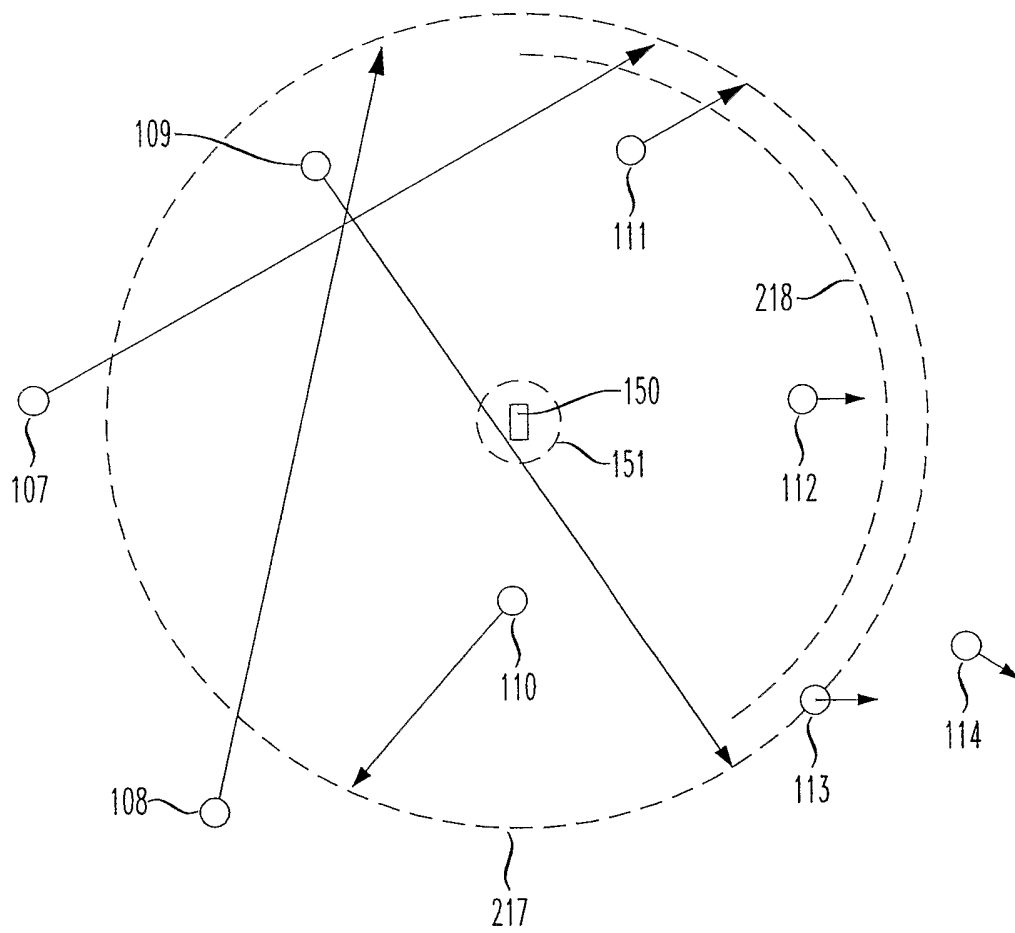

FIG. 2



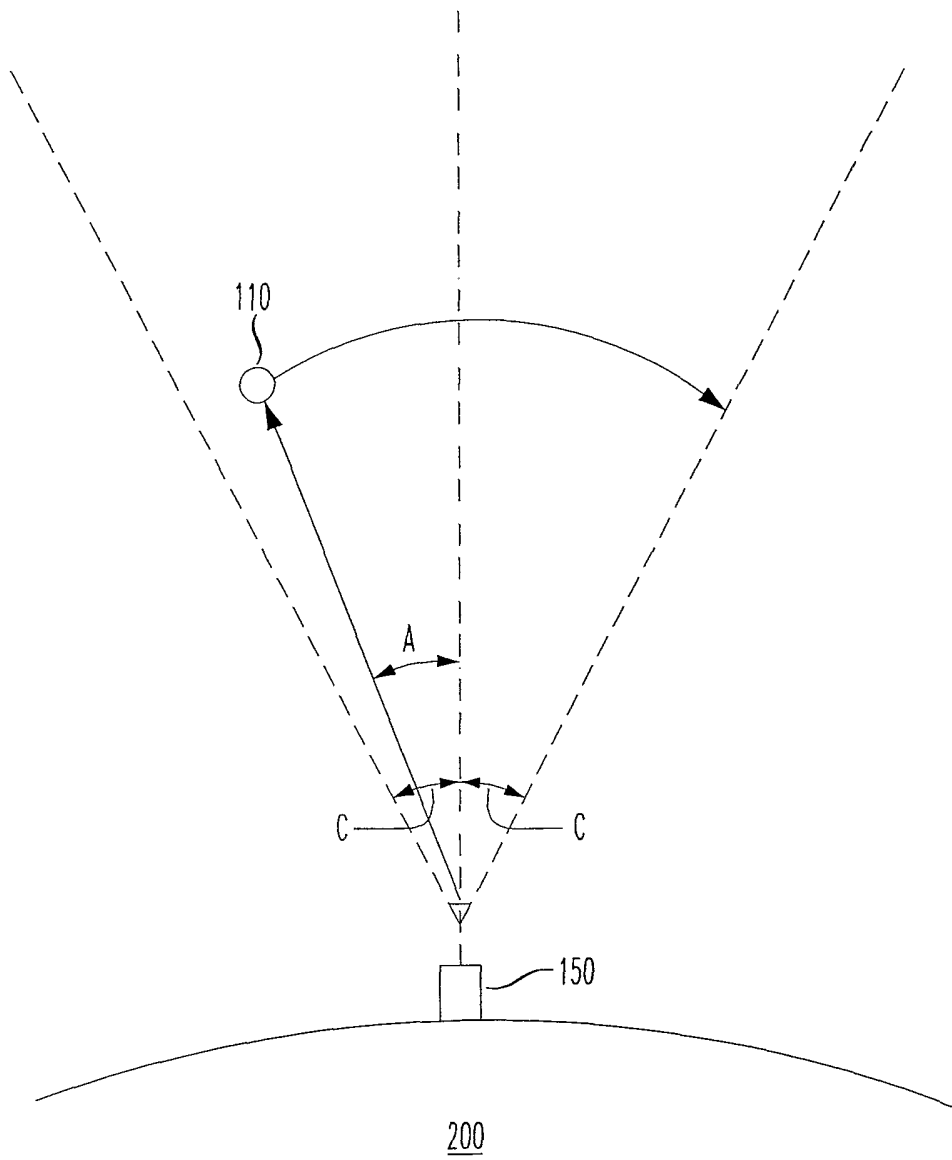

FIG. 3

100

BASE STATION
CULLED SAT. # 1
CULLED SAT. # 2
CULLED SAT. # 3
CULLED SAT # 4

CULLED GPS SATELLITE TABLE

FIG. 4

FIG. 5

100b

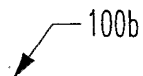

GPS SATELLITE ID	VISIBLE	CULLED, PREFERRED
SAT. # 1		
SAT. # 2		
SAT. # 3		
SAT. # 4		
SAT. # 5		
SAT. # 6		
SAT. # 7	X	
SAT. # 8	X	
SAT. # 9		X
SAT. # 10		X
SAT. # 11		X
SAT. # 12		X
SAT. # 13	X	
SAT. # 14	X	
SAT. # 15		
SAT. # 16		
SAT. # 17		
SAT. # 18		
SAT. # 19		
SAT. # 20		
SAT. # 21		
SAT. # 22		
SAT. # 23		
SAT. # 24		

ALTERNATE CULLED GPS SATELLITE INFORMATION

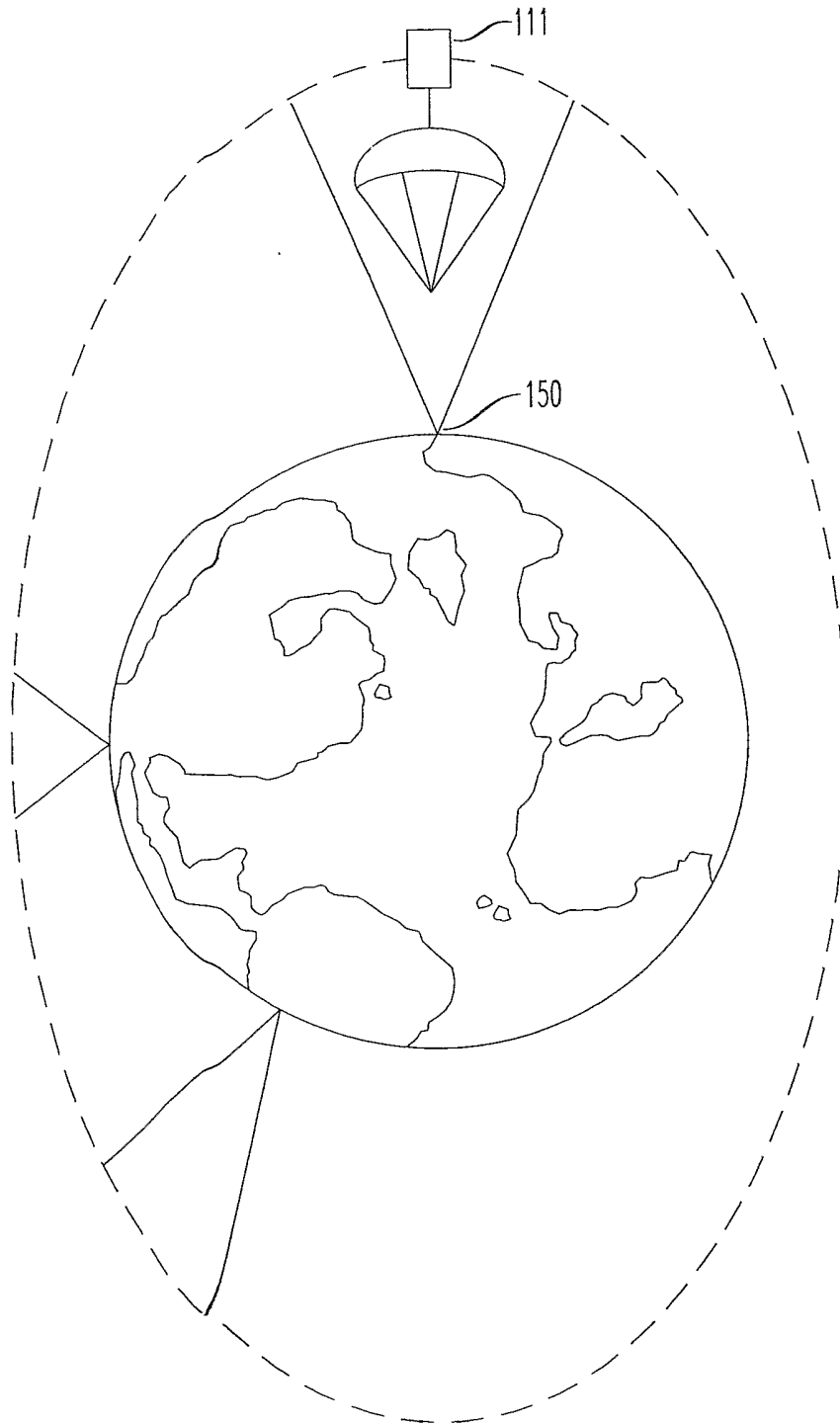

FIG. 6A

FIG. 6B

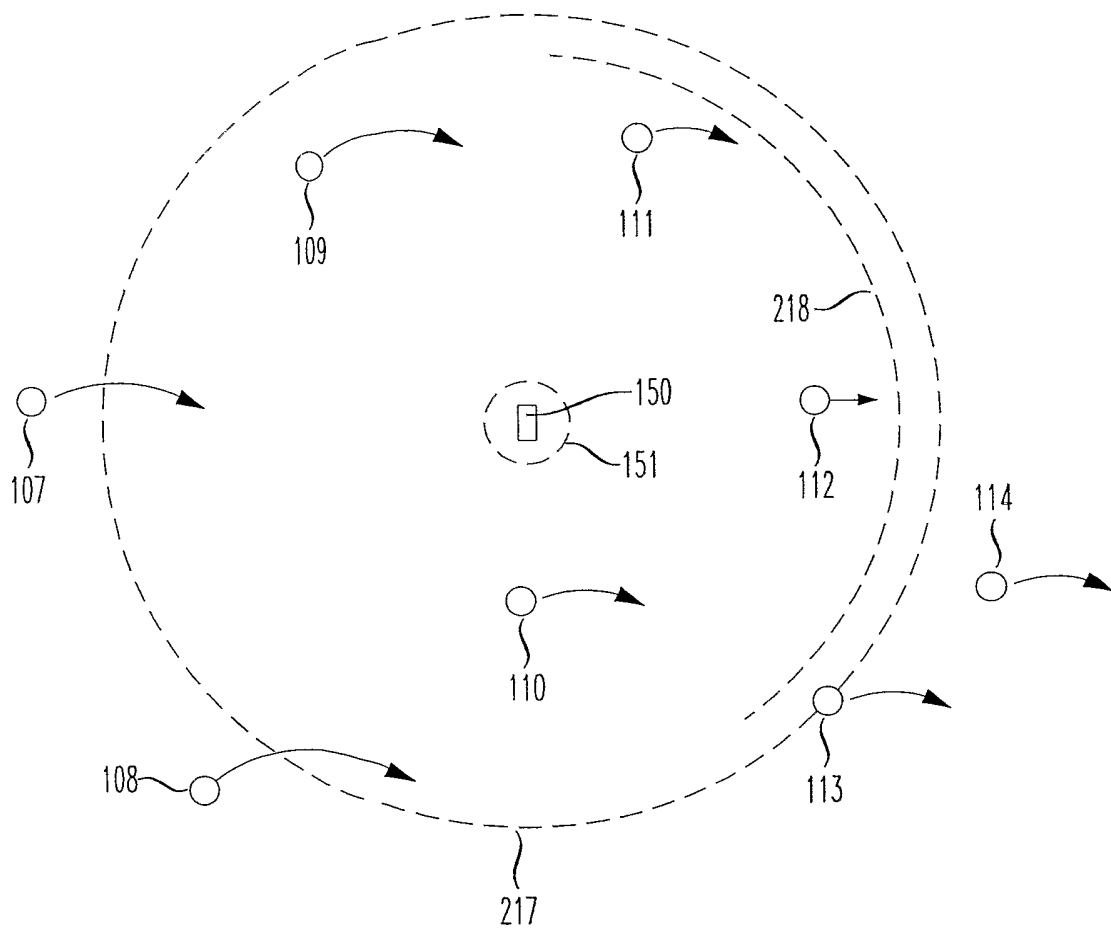
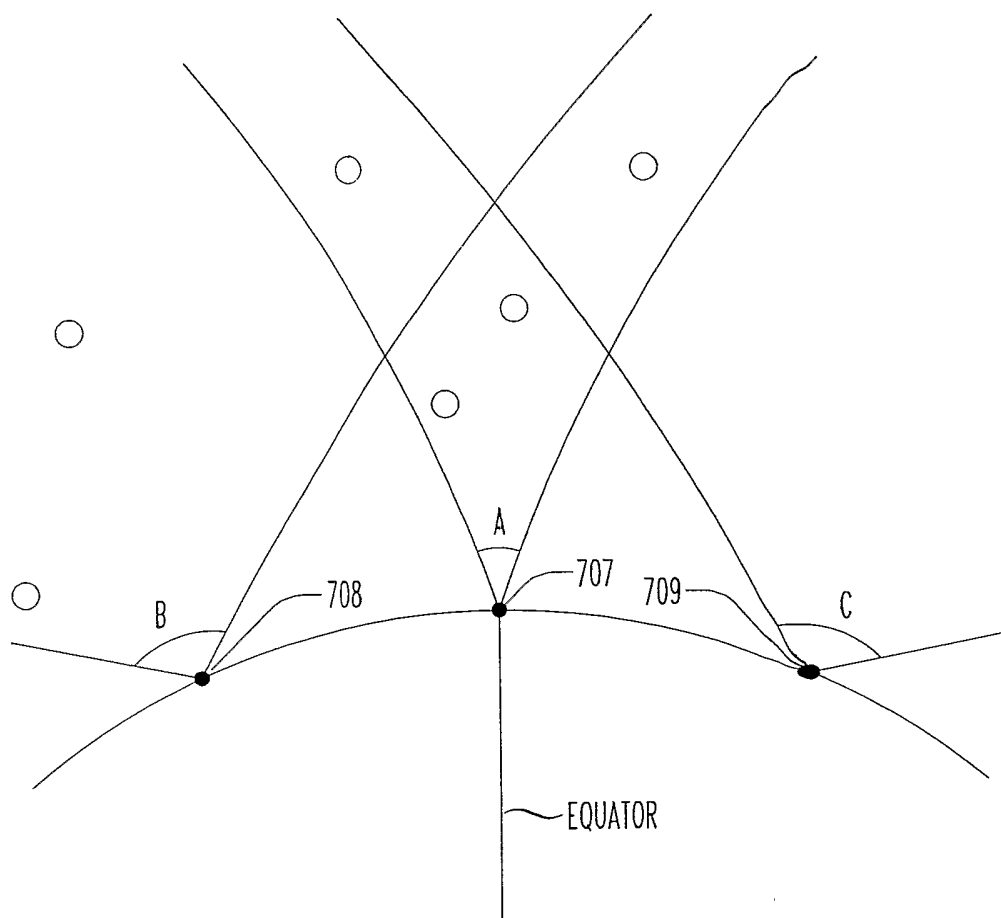

FIG. 7A



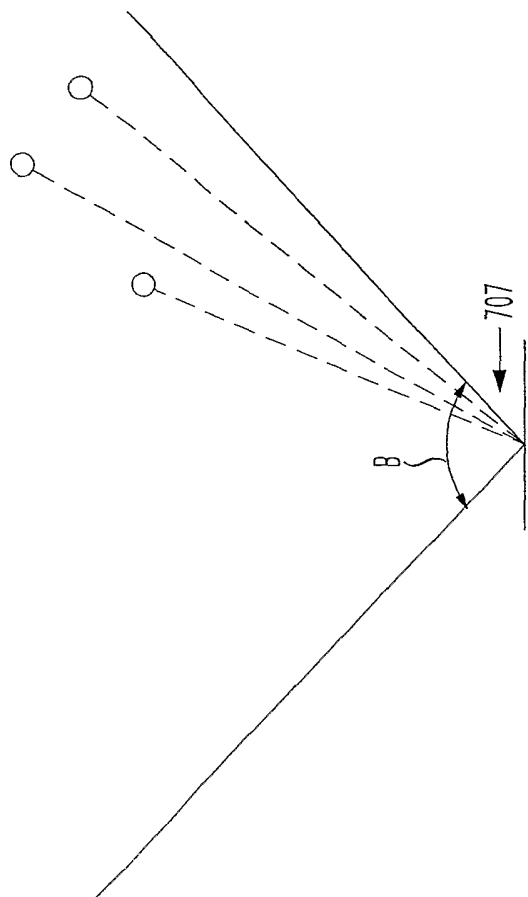

FIG. 7B(2)

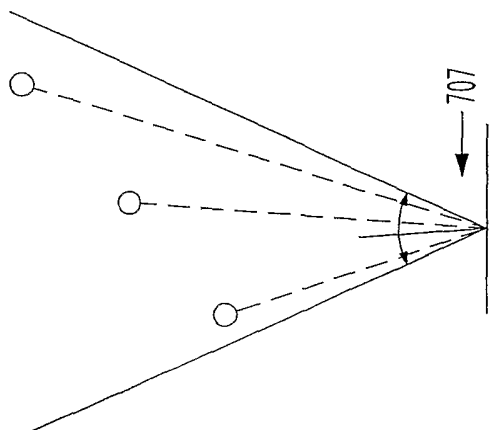

FIG. 7B(1)

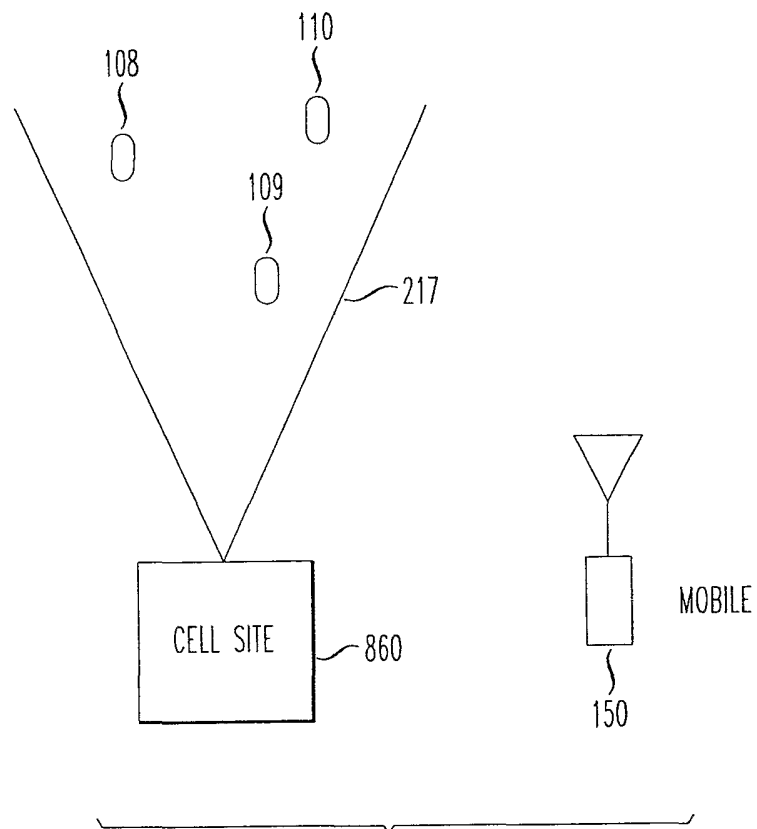

FIG. 8

100C

BASE STATION
CULLED SAT. # 1, PRIM
CULLED SAT. # 2, PRIM
CULLED SAT. # 3, PRIM
CULLED SAT. # 4, PRIM
CULLED SAT. # 5, PRIM
CULLED SAT. # 6, SEC.
CULLED SAT. # 7, SEC.
CULLED SAT. # 8, SEC.

CULLED LOCATING SATELLITE TABLE

FIG. 9A(1)

100C

BASE STATION
CULLED SAT. # 1, PRIM
CULLED SAT. # 2, PRIM
CULLED SAT. # 3, PRIM
CULLED SAT. # 4, PRIM
CULLED SAT. # 5, PRIM
CULLED SAT. # 6, SEC.
CULLED SAT. # 7, SEC.
CULLED SAT. # 8, SEC.

CULLED LOCATING SATELLITE TABLE

FIG. 9A(2)

FIG. 9B

100d



GPS SATELLITE ID	VISIBLE	CULLED	CULLED, PREFERRED
SAT. # 1			
SAT. # 2			
SAT. # 3			
SAT. # 4			
SAT. # 5			
SAT. # 6	X		
SAT. # 7		X	
SAT. # 8		X	
SAT. # 9			X
SAT. #10			X
SAT. #11			X
SAT. #12			X
SAT. #13		X	
SAT. #14	X		
SAT. #15	X		
SAT. #16			
SAT. #17			
SAT. #18			
SAT. #19			
SAT. #20			
SAT. #21			
SAT. #22			
SAT. #23			
SAT. #24			

ALTERNATE CULLED LOCATING SATELLITE INFORMATION

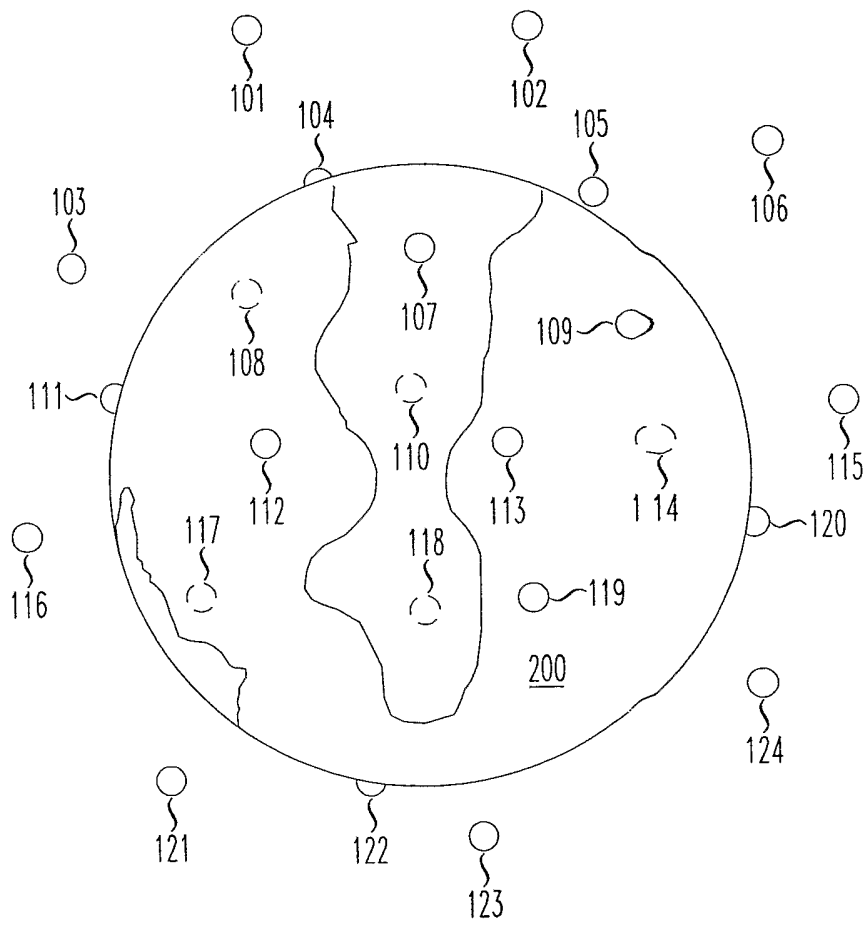

*FIG. 10*  
(PRIOR ART)

**INTERNATIONAL SEARCH REPORT**

International application No.

PCT/US05/34673

**A. CLASSIFICATION OF SUBJECT MATTER**

IPC(7) : H04B 7/185  
 US CL : 342/357.150

According to International Patent Classification (IPC) or to both national classification and IPC

**B. FIELDS SEARCHED**

Minimum documentation searched (classification system followed by classification symbols)  
 U.S. : 342/357.150, 357.09

Documentation searched other than minimum documentation to the extent that such documents are included in the fields searched

Electronic data base consulted during the international search (name of data base and, where practicable, search terms used)  
 EQUATOR; CULL; ELLIPSOID; CONE CONIC; MASK; LATITUDE

**C. DOCUMENTS CONSIDERED TO BE RELEVANT**

Category *	Citation of document, with indication, where appropriate, of the relevant passages	Relevant to claim No.
A	US 4,445,118 (TAYLPR ET AL.) 24 April 1984, see entire document.	
A	US 6,067,045 A (CASTELLOE ET AL.) 23 May 2000, see entire document.	
A	US 6,580,390 B1 (HAY) 17 June 2003, see entire document.	

Further documents are listed in the continuation of Box C.

See patent family annex.

\* Special categories of cited documents:

"A" document defining the general state of the art which is not considered to be of particular relevance	"T" later document published after the international filing date or priority date and not in conflict with the application but cited to understand the principle or theory underlying the invention
"E" earlier application or patent published on or after the international filing date	"X" document of particular relevance; the claimed invention cannot be considered novel or cannot be considered to involve an inventive step when the document is taken alone
"L" document which may throw doubts on priority claim(s) or which is cited to establish the publication date of another citation or other special reason (as specified)	"Y" document of particular relevance; the claimed invention cannot be considered to involve an inventive step when the document is combined with one or more other such documents, such combination being obvious to a person skilled in the art
"O" document referring to an oral disclosure, use, exhibition or other means	"&" document member of the same patent family
"P" document published prior to the international filing date but later than the priority date claimed	

Date of the actual completion of the international search

28 November 2005 (28.11.2005)

Date of mailing of the international search report

US DEC 2005

Name and mailing address of the ISA/US

Mail Stop PCT, Attn: ISA/US  
 Commissioner for Patents  
 P.O. Box 1450  
 Alexandria, Virginia 22313-1450

Authorized officer

Linda Shoff

Telephone No. (571) 272-4391

Facsimile No. (571) 273-3201