

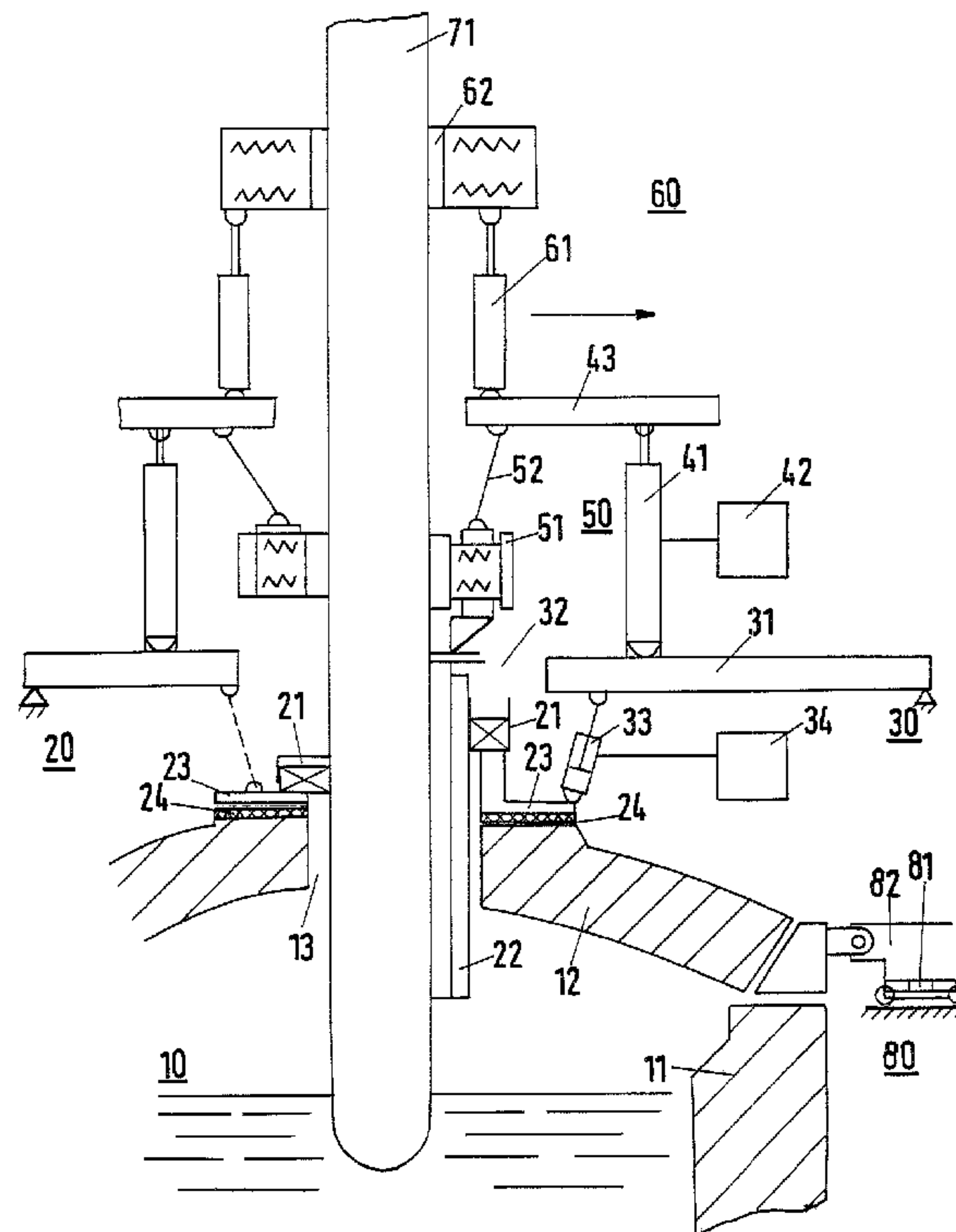

(86) Date de dépôt PCT/PCT Filing Date: 1994/11/30
 (87) Date publication PCT/PCT Publication Date: 1995/06/15
 (45) Date de délivrance/Issue Date: 2003/11/25
 (85) Entrée phase nationale/National Entry: 1996/06/07
 (86) N° demande PCT/PCT Application No.: DE 1994/001469
 (87) N° publication PCT/PCT Publication No.: 1995/016335
 (30) Priorité/Priority: 1993/12/08 (P 43 42 511.9) DE

(51) Cl.Int.⁶/Int.Cl.⁶ H05B 7/12, F27B 3/08
 (72) Inventeurs/Inventors:
 AMBROSI, LUCIANO, DE;
 SCHULZE-HAGEN, FRANZ, DE;
 CEPIN, HERMANN, DE
 (73) Propriétaire/Owner:
 MANNESMANN AG, DE
 (74) Agent: FETHERSTONHAUGH & CO.

(54) Titre : FOUR A ARC SUBMERGE A CADRE MOBILE EN HAUTEUR
 (54) Title: SUBMERGED ARC FURNACE WITH VERTICALLY MOVABLE FRAME



(57) Abrégé/Abstract:

The invention relates to a submerged arc furnace with open slag bath, in particular for melting powdery and fine-grained batches, having a vertically movable frame which is arranged above the furnace, closed by a cover, and on which an electrode mount and an electrode filling device are arranged. According to the invention, the reduction furnace is defined by the provision of a platform (31) on which the frame (43) is supported via at least three regulating cylinders (41), and by the platform (31), arranged above the furnace cover (12), being configured as a maintenance platform on which, for each electrode (71-73), there is provided a sealing unit (20) which has components (21, 23) for the horizontal and vertical sealing of the free surfaces between the electrodes and the electrode passage openings (13) of the cover (12).

Abstract

The invention relates to a submerged arc furnace with open slag bath, in particular for melting powdery and fine-grained batches, having a vertically movable frame which is arranged above the furnace, closed by a cover, and on which an electrode mount and an electrode filling device are arranged.

According to the invention, the reduction furnace is defined by the provision of a platform (31) on which the frame (43) is supported via at least three regulating cylinders (41), and by the platform (31), arranged above the furnace cover (12), being configured as a maintenance platform on which, for each electrode (71-73), there is provided a sealing unit (20) which has components (21, 23) for the horizontal and vertical sealing of the free surfaces between the electrodes and the electrode passage openings (13) of the cover (12).

Fig.

2178613

TRANSLATION

from:

Submerged arc furnace with vertically movable frame

The invention relates to a submerged arc furnace with open slag bath, in particular for melting powdery batches, having a vertically movable frame which is arranged above the furnace, closed by a cover, and on which an electrode mount and an electrode filling device are arranged, and to a device for sealing the electrode passage openings in the cover of a submerged arc furnace.

Electrodes in reduction furnaces are consumed at the electrode tip and must be filled during operation. Such a filling device for the electrodes of electric furnaces, having a double-acting hydraulic drive consisting of a piston/cylinder arrangement and intended for pushing the electrodes through the contact mount is disclosed, for example, by DE AS 1 440 991. The filling device which is disclosed by this document, and also the electrode mount, are fastened on a frame which is borne by an electrode winch. In this document, means are indicated with which shock-free and speed-regulating filling of the individual electrodes through the electrode mount can be carried out uniformly during the entire lowering operation. It is possible to see neither simultaneously controlled lowering of the electrodes nor reliable sealing of the electrode passages through the cover.

The document EP 0 093 070 B1 discloses a sealing system for electrodes, in which an annular stuffing box is pressed

LAWYERS' AND MERCHANTS' TRANSLATION BUREAU INC.

Legal, Financial, Scientific, Technical and Patent Translations
11 BROADWAY, NEW YORK, NY 10004

Tel: (212) 544-2930/2931

Consultant

WM. BERTSCHE, J.D., CHE., ACS

Fax: (212) 422-6877

Founded in 1903 by

CARL V. BERTSCHE

2178613

TRANSLATION

- 2 -

from:

onto the outer surface of the electrode. Furthermore, a chamber is provided which encompasses the electrode and can be loaded using compressed air. The entire sealing ring is screwed fast to the furnace cover and thus cannot be easily detached from the latter.

The document DE OS 24 55 202 discloses a main ring seal for use in conjunction with an arc furnace which has a furnace cover of fire-resistant material, in which excessively filled openings are provided, the main ring seal being supported above, and independently of, the fire-resistant furnace cover using a support structure. For this purpose, pivotable connecting elements are used which permit a lateral movement and an offset of the main ring seal with respect to the furnace cover. Furthermore, the main ring seal can be sealed off in relation to the furnace cover using an adjustable cylindrically designed part. Provided on the cover is an annular cover seal which is dimensioned such that it can be adjusted in the manner of a telescope in relation to the lower cylindrical part with close contact, the contact being improved further by means of a resilient element. This complicated construction only permits a cover change which involves a high degree of outlay. The invention pursues the aim of providing, using simple constructional means, a generic submerged arc furnace and a sealing device for the electrode passage openings in the cover, both of which

LAWYERS' AND MERCHANTS' TRANSLATION BUREAU INC.

Legal, Financial, Scientific, Technical and Patent Translations

Tel: (212) 344-2900/2931

11 BROADWAY, NEW YORK, NY 10004

Consultant

WM. BERTSCHE, I.D., CHE., ACS.

Fax: (212) 422-6877

Founded in 1903 by

CARL V. BERTSCHE

20337-458

-3-

guarantee reliable control of the electrode movement and with which, in a maintenance-friendly manner, an increase in the useful operational time may be achieved.

According to a broad aspect of the invention,
5 there is provided a submerged arc furnace with open slag bath, in particular for melting powdery and fine-grained batches, having a vertically movable frame which is arranged above the furnace, closed by a cover, and on which an electrode mount and an electrode filling device are
10 arranged, wherein provision is made of a platform (31) on which the frame (43) is supported via at least three regulating cylinders (41), and wherein the platform (31), arranged above the furnace cover (12), is configured as a maintenance platform, on which, for each electrode (71-73),
15 there is provided a sealing unit (20) which has components (21, 23) for the horizontal and vertical sealing of the free surfaces between the electrodes and electrode passage openings (13) of the cover (12).

According to another broad aspect of the
20 invention, there is provided a submerged arc furnace having a device for sealing electrode passage openings in a cover (12), wherein provision is made of a piston/cylinder unit (33) which is connected to a control unit (34) and, suspended on a platform (31), is connected to a sealing
25 frame (21), encompassing the individual electrodes (71-73) and intended for horizontal sealing, and to a flange (23), connected to the sealing frame, arranged parallel to the cover opening (13) and intended for vertical sealing, with which piston/cylinder unit, in the event of a change in
30 height (H) of the edge of the cover opening (13) during the operation of the submerged arc furnace, a constant force may be exerted on a vertical seal

20337-458

-3a-

According to the invention, it is proposed to connect piston/cylinder arrangements to the frame to which the electrode mount and the filling device are fastened, the piston/cylinder arrangements being supported on a stationary
5 regulating platform. Using the movement of this frame, the electrodes, as a rule 3 are used, are moved simultaneously. The filling and remounting of each individual electrode is achieved using the clamping rings in combination with the mount. The simultaneous regulation of all three electrodes
10 is possible in the case of submerged arc furnaces which operate with an open slag bath. Such furnaces are used in the processing of dusts or similar raw materials. In this case, the powdery batches are preferably charged via hollow electrodes. The remaining charging material, predominantly
15 coke and additives, is charged via charging pipes onto the hot, liquid slag and floats on the slag. The slag surface and the batch surface have, in this case, no noticeable unevenness.

2178613

TRANSLATION

- 4 -

from:

The electrode lead-throughs through the furnace cover can be designed in a dust-tight or else gas-tight manner. In this respect, a particular problem is posed by the thermal deformation of the cover. The inventors therefore propose to position a seal on the edge of the cover opening during the operation of the submerged arc furnace, which seal, at a constant force, absorbs any arbitrary movements parallel to the electrode axis and closes off the cover opening vertically in a reliable manner.

The covers are regularly bricked up and are subjected to incalculable wear. This results in their having to be changed spontaneously. In the case of the inventive embodiment of the seal of the electrode lead-through, this is possible in a simple manner and in the shortest possible time. For this purpose, the pressure cylinders which are fastened to the maintenance platform are driven back, the seal being detached from the furnace cover. At the same time, the electrodes are driven out of the electrode lead-through. Subsequently, the free cover can be removed using simple means and a prepared overhauled cover can in turn be placed on the furnace in a simple manner. The electrode lead-throughs are then closed once more, the electrodes are brought into the operating position and production can be resumed once more.

In a particular refinement, each electrode is surrounded in the region of the sealing unit by a sealing sleeve, which

LAWYERS' AND MERCHANTS' TRANSLATION BUREAU INC.

Legal, Financial, Scientific, Technical and Patent Translations

Tel: (212) 344-2930/2931

11 BROADWAY, NEW YORK, NY 10004

Consultant

WM. BERTSCHE, J.D., CHE., ACS.

Fax: (212) 422-6877

Founded in 1903 by
CARL V. BERTSCHE

2178613

TRANSLATION

- 5 -

from:

is encompassed by the sealing frame. The outer surface of the sealing sleeve is mechanically worked, so that it can slide in the sealing ring frame easily and without developing a leak. In the case of a planned cover change, the electrode is then withdrawn into the sealing sleeve and both are moved vertically to such an extent that their tips are located above the horizontal surface of the sealing flange. Then, by means of actuating the piston/cylinder unit, the sealing unit is lifted to such an extent that the cover can be moved horizontally freely under the latter.

The mounting rings encompassing the electrode are designed in one piece with the advantage of maintaining their exact shape and of low wear. The rings are suspended in an insulated manner; this avoids power losses and fulfills safety aspects for walking on the frame.

The power supply is minimized overall in terms of its length. This is also achieved, inter alia, by means of the use of the frame and the omission of special outriggers, since the center of gravity of the string, including the electrodes, is lower down than in the case of the conventional design.

As a result of the two-point engagement of the electrodes, namely the electrode mount and the filling device, and the simultaneous movement of all the electrodes in the vertical direction, the electrodes are free of lateral

LAWYERS' AND MERCHANTS' TRANSLATION BUREAU INC.

Legal, Financial, Scientific, Technical and Patent Translations

Tel: (212) 344-2930/2931

11 BROADWAY, NEW YORK, NY 10004

Consultant

WM. BERTSCHE, I.D., C.H.E., A.C.S.

Fax: (212) 422-6877

Founded in 1903 by

CARL V. BERTSCHE

TRANSLATION

- 6 -

from:

forces.

One example of the invention is set forth in the appended drawing. In this case, the single figure shows a detail of a submerged arc furnace with a cover section.

A vessel 11 is shown with a cover 12 of a submerged arc furnace 10. An electrode 71 projects into the vessel 11 through a cover opening 13.

The electrode 71 is gripped by a clamping ring 62 of a filling device 60, which is supported on a frame 43 via a lifting cylinder 61.

Fastened on the frame 43 is an electrode mounting holder 52, on which there is arranged an electrode mounting ring 51, which likewise encompasses the electrode 71.

The frame 43 is supported via a regulating cylinder 41, which is connected to a synchronous controller 42, on a regulating and maintenance platform 31 of a maintenance unit 30. The regulating and maintenance platform 31 in this case has a passage 32, in the area of which there is fastened a piston/cylinder unit 33, which is connected to a control unit 34.

The piston/cylinder unit 33 is connected to a sealing unit 20. This sealing unit 20 has a flange 23 which is guided parallel to the cover opening 13, elastically deformable material 24 being provided between the two. It is possible to use a heat-resistant silicon compound or a metallic

LAWYERS' AND MERCHANTS' TRANSLATION BUREAU INC.

Legal, Financial, Scientific, Technical and Patent Translations

Tel: (212) 244-2930/2931

11 BROADWAY, NEW YORK, NY 10004

Consultant

WM. BERTSCHE, J.D., CHE., ACS

Fax: (212) 422-6877

Founded in 1903 by
CARL V. BERTSCHE

2178613

TRANSLATION

- 7 -

from:

compensator here. The flange is connected to a sealing frame, which directly encompasses the electrode - as shown on the left-hand side of the figure - or encompasses a sealing sleeve 22. The use of a sealing sleeve 22 has the advantage that defined relationships between the contact surfaces are produced by means of mechanical working of the outer surface. Leak-tight and reliable sliding of the electrode unit during the planned cover changes is thus guaranteed.

During a cover change, use is made of a lifting and driving unit 80, which has a lifting element 81 and a driving element 82 and, following the detachment of the flanges 23 from the cover opening and the withdrawal of the electrode and, if appropriate, of the sealing sleeve, the cover moves away from the vessel 11 without impediment.

LAWYERS' AND MERCHANTS' TRANSLATION BUREAU INC.

Legal, Financial, Scientific, Technical and Patent Translations

Tel: (212) 344-2930/2931

11 BROADWAY, NEW YORK, NY 10004

Consultant

WM. BERTSCHE, J.D., C.H.E., A.C.S.

Fax: (212) 422-6877

Founded in 1913 by
CARL V. BERTSCHE

20337-458

- 8 -

CLAIMS:

1. A submerged arc furnace with open slag bath, in particular for melting powdery and fine-grained batches, having a vertically movable frame which is arranged above
5 the furnace, closed by a cover, and on which an electrode mount and an electrode filling device are arranged, wherein provision is made of a platform (31) on which the frame (43) is supported via at least three regulating cylinders (41), and wherein the platform (31), arranged above the furnace
10 cover (12), is configured as a maintenance platform, on which, for each electrode (71-73), there is provided a sealing unit (20) which has components (21, 23) for the horizontal and vertical sealing of the free surfaces between the electrodes and electrode passage openings (13) of the
15 cover (12).

2. The submerged arc furnace as claimed in claim 1, wherein the regulating cylinders (41) are equipped with a synchronous controller (42).

3. The submerged arc furnace as claimed in claim 1,
20 wherein one of the components of the sealing unit (20) is a sealing frame (21) which encompasses the individual electrodes (71, 73) as a closed ring.

4. The submerged arc furnace as claimed in claim 3,
25 wherein there is provided between each sealing frame (21) and the individual electrodes (71-73), coaxial to the latter, a sealing sleeve (22), the outer surface of which is mechanically worked and can be brought into sliding contact with the inner surfaces of the sealing frame (21).

5. The submerged arc furnace as claimed in claim 3,
30 wherein there is provided on the sealing frame (21) a flange (23) which is guided parallel to the cover (12) and bears

20337-458

- 9 -

against the edge of the electrode passage opening (13) via a sealing means (24).

6. The submerged arc furnace as claimed in claim 5, wherein the sealing means (24) consists of elastically
5 deformable sealing material, for example a silicon compound.

7. A submerged arc furnace having a device for sealing electrode passage openings in a cover (12), wherein provision is made of a piston/cylinder unit (33) which is connected to a control unit (34) and, suspended on a
10 platform (31), is connected to a sealing frame (21), encompassing the individual electrodes (71-73) and intended for horizontal sealing, and to a flange (23), connected to the sealing frame, arranged parallel to the cover opening (13) and intended for vertical sealing, with which
15 piston/cylinder unit, in the event of a change in height (H) of the edge of the cover opening (13) during the operation of the submerged arc furnace, a constant force may be exerted on a vertical seal.

8. A submerged arc furnace as claimed in claim 7,
20 wherein, when the furnace is stopped, the flange (23) provided for vertical sealing can be lifted off the edge of the cover opening (13) using the piston/cylinder unit (33).

9. A submerged arc furnace as claimed in any one of claims 1 to 8, wherein the cover (12) can be coupled to a
25 lifting and driving unit (80), with which the cover (12) can be brought into a repair position outside the furnace vessel (11) when the flange (23) is lifted.

2178613

1/1

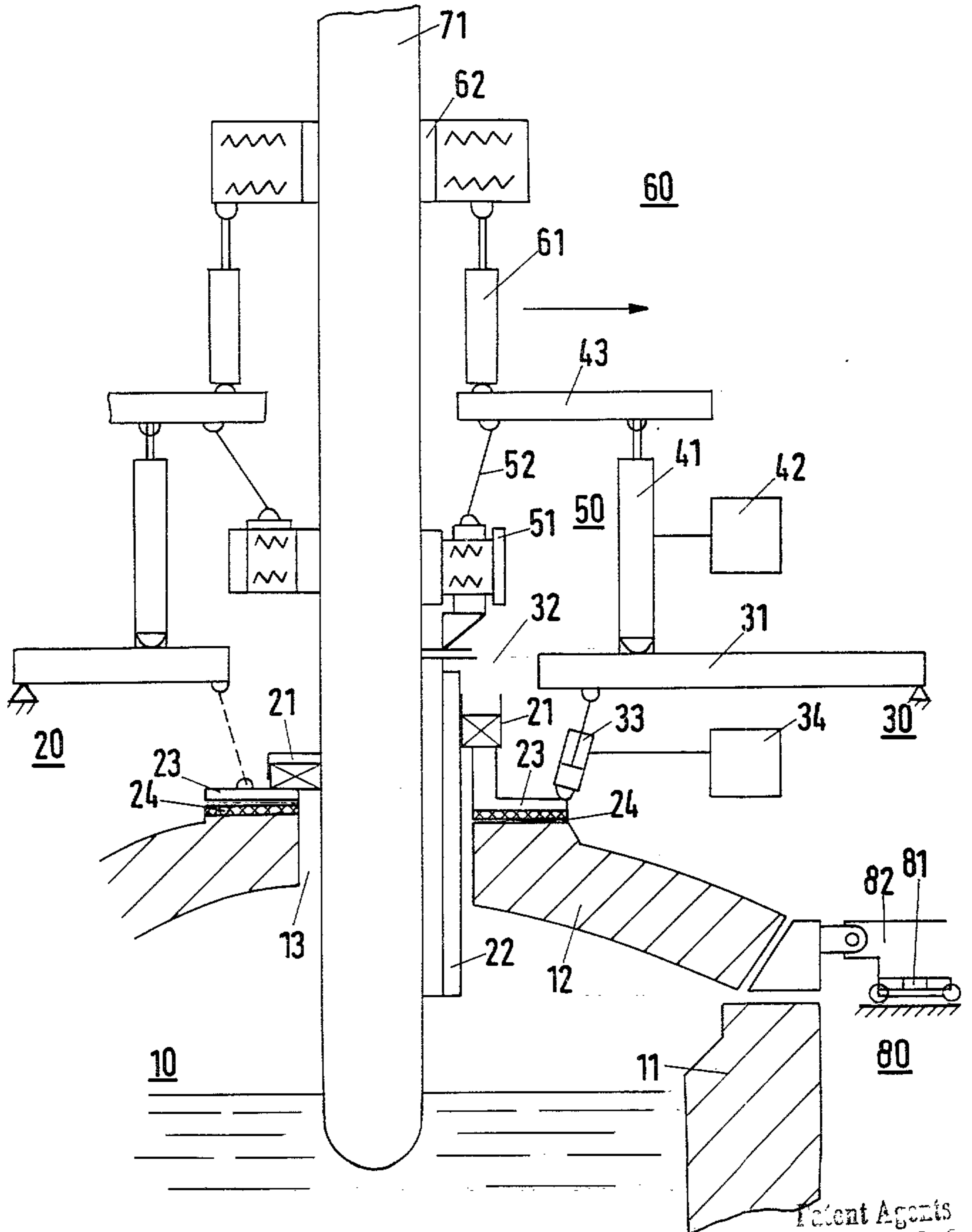

Patent Agents
Fetherstonhaugh & Co

