

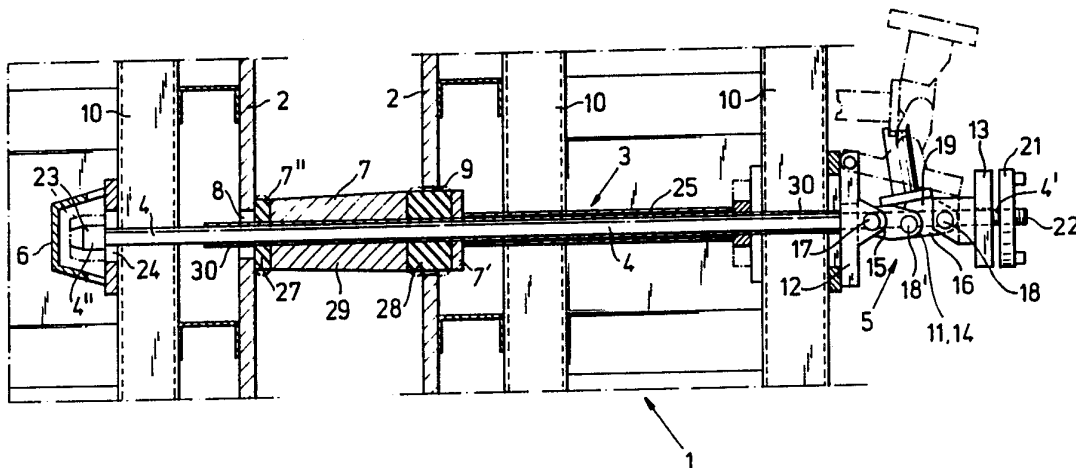

## INTERNATIONAL APPLICATION PUBLISHED UNDER THE PATENT COOPERATION TREATY (PCT)

<p>(51) International Patent Classification <sup>5</sup> : E04G 17/075</p>	<p>A1</p>	<p>(11) International Publication Number: <b>WO 92/12308</b> (43) International Publication Date: 23 July 1992 (23.07.92)</p>
<p>(21) International Application Number: PCT/SE92/00015 (22) International Filing Date: 13 January 1992 (13.01.92) (30) Priority data: 9100094-3 11 January 1991 (11.01.91) SE (71)(72) Applicant and Inventor: TARALDSSON, Leif, Börje [SE/SE]; Box 64, S-610 70 Vagnhärad (SE). (74) Agent: ÖRTENBLAD, Bertil; Noréns Patentbyrå AB, Box 27034, S-102 51 Stockholm (SE). (81) Designated States: AU, BR, CA, JP, PL, RU</p>		<p>Published <i>With international search report.</i></p>

(54) Title: A CLAMPING AND FIXING DEVICE, FORM TIE AND FORM



## (57) Abstract

This invention relates to a clamping and fixing arrangement which functions to fixate the various elements of formwork or shuttering, preferably intended for moulding concrete. The arrangement is mainly characterized by an excentric locking device which is provided with an expandable excentric part (11) and which has a predetermined axial extension in an expanded state and an axial extension which is smaller than the predetermined axial extension in a non-expanded state. The invention also relates to a form tie and to formwork or shuttering.

**FOR THE PURPOSES OF INFORMATION ONLY**

Codes used to identify States party to the PCT on the front pages of pamphlets publishing international applications under the PCT.

AT	Austria	ES	Spain	MG	Madagascar
AU	Australia	FI	Finland	ML	Mali
BB	Barbados	FR	France	MN	Mongolia
BE	Belgium	GA	Gabon	MR	Mauritania
BF	Burkina Faso	GB	United Kingdom	MW	Malawi
BG	Bulgaria	GN	Guinea	NL	Netherlands
BJ	Benin	GR	Greece	NO	Norway
BR	Brazil	HU	Hungary	PL	Poland
CA	Canada	IT	Italy	RO	Romania
CF	Central African Republic	JP	Japan	RU	Russian Federation
CG	Congo	KP	Democratic People's Republic of Korea	SD	Sudan
CH	Switzerland	KR	Republic of Korea	SE	Sweden
CI	Côte d'Ivoire	LI	Liechtenstein	SN	Senegal
CM	Cameroon	LK	Sri Lanka	SU	Soviet Union
CS	Czechoslovakia	LU	Luxembourg	TD	Chad
DE	Germany	LV	Latvia	TG	Togo
DK	Denmark	MC	Monaco	US	United States of America

A Clamping and Fixing Device, Form Tie and Form

The present invention relates to a clamping and fixing device primarily intended for concrete forms or shuttering and functioning to hold various components, such as form elements, in desired mutual positions.

The invention also relates to a form tie intended primarily for concrete forms or shuttering and functioning to hold a form or shuttering comprising mutually opposing form bottoms provided with form boards or shuttering panels in desired positions. The concrete is intended to be cast against the form boards and the form will include at least one tension element which extends between opposing boards, and two fixating elements provided to secure the tension element externally of the boards, and will also include a sealing element in which the tension element is intended to extend between the boards and which effects a seal in the vicinity of two opposing holes in said boards, the tension element being intended to extend through said holes.

The invention also relates to a form, primarily a concrete form or shuttering.

According to known techniques, certain clamping and fixating problems are solved, at least when casting concrete is concerned, by means of wedging devices. One drawback with such arrangements is the loud noise that is generated when the wedges concerned are knocked into place and also when knocked out of place, with the aid of sledge hammers or the like. The present invention relates to a clamping and fixating arrangement which is extremely quiet and rapid, among other things.

Form ties of essentially the aforesaid kind are known to the art. Swedish Patent Application No. 8405045-9 teaches a form tie which can be mounted from the outside of one of the opposing form bottoms, by passing a  
5 tension rod through mutually opposing holes in the boards and causing one end thereof to coact with a fastener element provided on the outside of the other form bottom, and fastening the tension rod on the  
10 outside of said one form bottom by means of a wedge arrangement. Also provided is an expandable sleeve which can be expanded into sealing engagement with said holes.

15 This known technique, and more conventional form-tie technique, is encumbered with serious drawbacks. For example, the wedge arrangement described above, which is also used in more conventional ties, frequently  
20 requires the use of sledge hammers or like tools, which results in injury, damage, noise pollution, etc. The known techniques are also highly time-consuming and problems are encountered with the reuse of sealing devices, among other things.

25 The drawbacks of the known techniques are not found with the present invention. Thus, the inventive form tie can be quickly removed in a simple and quiet manner. Injuries and damage are avoided, and the components can be reused to a very high degree.

30 The invention thus relates to a clamping and fixating arrangement which is primarily intended for concrete forms or shuttering and which is intended to hold individual form elements in desired mutual positions.

The arrangement is mainly characterized by an excentric locking device which has an expandable excentric part and which is intended to have a predetermined axial extension or length when expanded and a smaller axial extension of length than said predetermined length when not expanded.

The invention also relates to a form tie which is intended primarily for concrete forms or shuttering and which functions to hold in a desired position a form or shuttering that comprises opposing form bottoms provided with form boards, wherein the concrete is cast against the form boards; and which includes at least one tension element which extends between opposing boards; two tension-element fixating or securing elements located externally of the form boards; and a sealing element in which the tension element is intended to extend between said boards and which functions to seal two mutually opposing holes in the boards, said tension element being intended to extend through said holes.

The form tie is mainly characterized in that it includes a first fixating element which comprises an excentric locking device which has an expandable excentric part and which, in an expanded locking position, functions to provide a predetermined greatest distance between the form boards and to transmit tension forces acting in the tension element in the form of compression forces to the form bottom, at which the excentric locking device is arranged.

The invention also relates to a form or shuttering for casting primarily concrete and comprising at least two form elements which are held fixated relative to one

another by means of clamping and fixating devices, when casting is taking place. The form is mainly characterized in that the clamping and fixating devices include an excentric locking device which is provided with an expandable excentric part and which has a predetermined axial extension or length in its expanded state and an axial extension or a length which is shorter than said predetermined length when in its non-expanded state.

The invention will now be described with reference to exemplifying embodiments thereof and also with reference to the accompanying drawings, in which

- Figure 1 is a schematic, vertical and central sectional view of a first embodiment of an inventive form tie mounted adjacent two form bottoms;
- Figure 2 illustrates the arrangement of Figure 1 as seen from the right in said Figure;
- Figure 3 is a schematic vertical and central sectional view of a second embodiment of an inventive form tie mounted adjacent two form bottoms;
- Figure 4 illustrates the arrangement of Figure 3 as seen from the right in said Figure;
- Figure 5 illustrates a tension element as seen transversely to its longitudinal axis;
- Figure 6 illustrates the tension element of Figure 5 as seen from the left in said Figure;
- Figure 7 illustrates a fixating element which is intended for coaction with the tension element of Figure 5 and 6, seen in the direction of its longitudinal axis;
- Figure 8 illustrates schematically a first embodiment of an inventive form, in which two form-bottom parts, seen from the outside, are joined by means

of excentric locking devices;

- Figure 9 illustrates schematically a second embodiment of an inventive form, where the form comprises a form for producing window and door openings and with which form elements are held at predetermined distances from one another by means of excentric locking devices, and in which Figure the form is shown at right angles to the plane of the main extension of the window or door opening;
- 5
- 10 - Figure 10 illustrates schematically a third embodiment of an inventive form consisting of an internal form or shuttering for producing shafts, and with which the form elements are held at predetermined distances from one another by means of excentric locking devices, said Figure showing the form in the intended direction of the shaft;
- 15
- Figure 11 illustrates schematically a second embodiment of excentric locking, according to the invention, seen transversely to the expansion direction and parallel with the rotational axis or axes of the linkage arms provided, said Figure illustrating a non-expanded state of said excentric locking device;
- 20
- Figure 12 illustrates the arrangement shown in Figure 11 but with the excentric locking device in its expanded state;
- 25
- Figure 13 illustrates a left-hand support part according to Figure 11, seen from the right in said Figure;
- 30
- Figure 14 illustrates a right-hand support part according to Figure 11, seen from the right in said Figure;
- Figure 15 illustrates a left-hand linkage arm according to Figure 12, seen from the right in said Figure;
- 35

- Figure 16 illustrates a right-hand linkage arm according to Figure 11, seen from the right in said Figure; and
- Figure 17 is an axial section view through a second embodiment of a second fixating element, said Figure showing both the locked and the non-locked states.

10 In Figure 1, the reference numeral 1 identifies form bottoms, more specifically two mutually opposing form bottoms each of which includes respective form boards 2, wherein concrete or the like is intended to be cast between the form bottoms 1 against the form boards 2. The reference numeral 3 identifies a form tie which  
15 functions to hold the form bottoms, and therewith also the form boards, in desired mutual positions, and includes at least one tension element 4 which extends between the panels 2 and connects the form bottoms, and at least two tension-element securing or fixating  
20 elements 5, 6 arranged externally in relation to the form boards, and a sealing element 7 through which the tension element is intended to pass between the panels and which is intended to lie sealingly against two mutually opposing holes 8, 9 in the form boards, said  
25 tension element extending through said holes.

In addition to the form boards 2, the form bottoms 1 also include load-bearing parts 10, for example in the form of vertically extending columns.

30 The reference numeral 5 identifies a first fixating or securing element which includes an excentric locking device provided with an expandable excentric part 11 and, when in an expanded locking state, providing a  
35 predetermined greatest distance between the form boards

and also functioning to transmit the tension forces acting in the tension element during a casting operation to the form bottom in the form of compression forces, said excentric locking device being mounted adjacent said bottom.

In the illustrated embodiment, the excentric locking device comprises a first support part 12 which is intended to support against load-bearing parts 10 of the form bottom, such as load-bearing parts 10 in the form of form joists or columns 10, and a second support part 13 which is intended to support against a stop means located adjacent the tension element 4, so as to enable the tension element to be placed under tension. The support parts 12, 13 are pivotally connected to an excentric, expandable linkage-arm arrangement 14 which in a first position or state, a non-expanded state, functions to hold the support parts 12, 13 close together in the direction of the longitudinal axis of the tension element, the tension element preferably being relieved of load, and, in a second positional state, an expanded state, functions to hold the support parts spaced from one another in the longitudinal direction of the tension element, said tension element optionally being placed under tension. Figure 1 shows the aforesaid non-expanded state.

The illustrated embodiment includes linkage arms 15, 16 which are pivotally mounted on mutually parallel pivot shafts 17, 18, 18' which extend transversely to the longitudinal direction of the tension element, and which, in this case, are connected to respective support parts 12, 13. Some of the linkage arms 16 are connected to an excentric 19 which can be pivoted around a pivot axis which extends substantially

parallel with the pivot shafts or axes of the linkage arms, wherein the excentric locking device is switched between its non-expanded state and its expanded state by rotating of the excentric 19, and wherein the expanded state, and preferably also the non-expanded state, constitute stable excentric-locking states.

Preferred embodiments are those in which both the support parts and the excentric has parts on both sides of the longitudinal axis of the tension element, as illustrated in Figure 3, in which case the longitudinal axis of said tension element preferably forms a symmetry line.

As illustrated in broken lines in Figure 1, it is also preferred that part of the excentric locking device can be dropped away from the tension element, so as to enable the tension element to be withdrawn and removed from the form. Shown in the drawings is an embodiment in which said second support part has provided therein a U-shaped aperture or slot 20 which enables the support part to straddle the tension element. Also shown is an embodiment in which the end 4' of the tension element intended for coaction with the excentric locking device is provided with a stop-means 21 which can be moved in the direction of the longitudinal axis of the tension element and which functions to subject the tension element to tension forces. In the illustrated case, the stop-means is moved by means of screw threads or helix 22. In the case of the embodiment illustrated in Figures 1 and 2, parts of the excentric locking device can be moved towards and away from the tension element in a substantially vertical plane. In the embodiment illustrated in Figures 3 and 4, such movement can be effected substantially horizontally,

through the intermediary of a U-shaped aperture 20, among other things.

5 The second fixating or securing element 6 is intended to detachably coact with an end part 4" of the tension element opposite said excentric locking device in a manner to maintain tension force in the tension element, said tension element being brought into coaction with the fixating element. According to one preferred  
10 embodiment, the aforesaid end-part 4" includes a portion 23 of elongated cross-section, such as an oval or rectangular cross-section, as seen transversely to the long axis of the tension element, wherein corresponding fixating elements include an elongated hole 24 into  
15 which the elongated portion 23 can be inserted when in a given rotational position, shown in broken lines in Figure 1, and which cannot be withdrawn from said hole when in another position of rotation, shown in full lines in Figure 1. The fixating element 6 of this  
20 embodiment is mounted adjacent a form column 10 of the form bottom 1.

According to another embodiment (not shown), the end-part 4" is screw-threaded and the fixating element  
25 includes a corresponding nut means.

The sealing element 7 is intended to coact sealingly with the mutually opposing holes 8, 9 provided in the form boards 2, while under axial compression. The  
30 reference 25 identifies a spacer arranged between an external part, such as a load-carrying part 10, of a form side and an end-part 7' of the sealing element, said spacer functioning to compress the sealing element axially. In the illustrated embodiment, the spacer is  
35 placed externally adjacent the same form bottom as the

excentric locking device and extends between a load-carrying part 10 of the form bottom and an end-part 7' of the sealing element projecting externally from the hole 9 facing towards the excentric locking device in a corresponding form side.

In the case of the illustrated configuration of the sealing element, the one end 7" of the sealing element, the end of the sealing element remote from the excentric locking device, covers one of said holes, the hole 8, internally of a form board and is pressed axially against shuttering or form parts which surround the periphery of said hole in order to effect a seal. Shown is an embodiment in which the end of the sealing element remote from the excentric locking device overlaps said hole.

Figure 3 illustrates an embodiment in which the sealing element is comprised essentially of an elastic sleeve 26, for instance a sleeve made of plastic material, a rubber-based material or the like, and is intended to be compressed pronouncedly in an axial direction and thus to expand radially and seal the holes 8, 9.

In the case of the Figure 1 embodiment, the sealing element 7 includes resilient parts 27, 28 for coaction with said holes 8, 9, these resilient parts being intended for pronounced axial compression and are supported by intermediate parts 29 which are not compressed to any great extent.

A preferred embodiment is one in which one end 7" of the sealing element covers the holes while the other end of said element extends through a hole and sealing is effected by radial expansion therein, for instance

in the hole 9.

5 According to one preferred embodiment, the resilient or elastic parts of the sealing element intended for axial compression are made of Adiprene or some similar material, where the elastomeric material will not fasten essentially onto concrete that comes into contact with the sealing element.

10 The aforesaid intermediate parts 29, which are not intended to be compressed axially, are preferably made of Robalon or some similar material, and are essentially conical in shape, thereby to facilitate withdrawal of said intermediate parts upon completion of a casting  
15 operation. The intermediate parts 29 are also not intended to fasten against the concrete, and are constructed to this end.

20 The reference 30 identifies a support tube in which the tension element extends, at least between the sides of the form.

25 In the embodiment of the tension element 4 and the fixating element 6 illustrated in Figures 5-7, at least the aforesaid end-part 4" includes a rod-like portion 31 having opposing cam parts 32 which give an elongated, oval, cross-sectional shape and which form a screw thread or helix, wherein corresponding fixating  
30 element 6 includes an elongated hole 24 provided with an internal screw thread 33, said holes and screw threads 33 being disposed such that the portion of elongated cross-sectional shape can be inserted into the elongated hole 24 in a given position of rotation and can be removed from said hole in another position  
35 of rotation.

According to one preferred embodiment, the tension element comprises an element retailed under the trade-name DIWIDAG. The fixating element 6 includes a nut which is retailed under the tradename DIWIDAG. The screw threads, however, are cut or machined on two diametrically opposing parts 34, so as to form said oval, cross-sectional shape.

The form embodiment illustrated in Figure 8 includes at least two form elements, form bottoms, arranged in sequential rows. The form elements are held clamped and fixed in relation to one another at a join 35 by means of at least one (in the illustrated case two) excentric locking device of essentially the kind described in the foregoing and including, among other things, an excentric part 11. The excentric locking device is intended to be in its expanded state when the form bottoms are clamped together. The form bottoms include fittings 36, 37 against which the excentric locking device will act in a manner to draw the form bottoms towards one another. In the illustrated case, a form bottom includes outwardly projecting tensioning means 37 in which a tension force which holds the form bottoms together can be applied by means of respective excentric locking devices.

Figure 9 illustrates a form which is intended for casting door openings, window openings and the like. This form includes at least two form elements 38 which are held at a predetermined distance from one another such as to define an opening of predetermined width, where casting is intended to be effected externally against the form elements, which are held at a given distance apart by means of at least one (in the

illustrated case three) excentric locking devices in an expanded state, said form elements including fittings 39 against which respective excentric locking devices are intended to act. The illustrated embodiment includes two form elements 38 in the form of substantially E-shaped frame elements disposed in opposing relationship. In this case, one excentric locking device is arranged to act between each pair of mutually opposing, horizontal element-parts 40.

10

The internal shaft-building form illustrated in Figure 10 includes two mutually opposite form elements 41, each of which comprises two side-parts 42 and an intermediate part 43, said parts forming a brace-like or clip-like cross-sectional shape. The form elements 41 are held at a given distance apart by means of at least two excentric locking devices which, in their expanded states, act between each pair of mutually opposing side-parts 42. In the case of the second embodiment of the clamping and fixating device illustrated in Figures 11-16, the excentric part 11 of the excentric locking device includes a linkage-arm arrangement 14 having two linkage arms, a first arm 44 and a second arm 45, which coact pivotally with a respective support part, a first support part 46 and a second support part 47, where the pivot joints permit rotation around mutually parallel pivot axles 48, 49, 50 which extend transversely to the expansion direction of the excentric locking device and where each pivot includes at least one axle element 51, part of which has a cylindrical configuration, and a seat 52 which has a part of cylindrical configuration and which is intended for at least one axle element.

15

20

25

30

35

In the illustrated embodiment, there is included a first linkage arm 44 which includes a corner part 53

which extends parallel with said pivot axles 48-50 and which carries at its extremity a bead 51 having a partially a cylindrical configuration and forming an axle element and which forms a stop surface 54, 55 on each side of said bead, and further includes two stop surfaces 56 located opposite said bead and separated by a seat 52. The axle element, the bead, for this linkage arm, and also for the second linkage arm, is comprised of two transversal parts where the linkage arm is intended to straddle a tension element. As will be evident from the following, the stop surfaces on the linkage arms and the support parts are arranged to define a distinct, non-expanded position, in which each of the linkage arms adopts a first limited rotational position, and a distinct expanded position in which each of the linkage arms takes a second limited rotational position.

The embodiment also includes a second linkage arm 45 which includes two beads 51 which are partially of cylindrical configuration and each of which forms an axle element 51 and are separated by an intermediate stop surface 57. The linkage arm also includes two opposing stop surfaces 58, 59 on opposite sides of the two beads in relation to said intermediate stop surface 57. Also included is a first support part 46 which is intended to coact with said first linkage arm and which includes two stop surfaces 60, 61 separated by an intermediate seat for the bead of the first linkage arm and each arranged for stopping coaction with a respective stop surface located on each side of the bead. The reference 47 identifies a second stop part which is intended to coact with said second linkage arm 45 and which includes two stop surfaces 62, 63 separated by an intermediate seat 52 for the one and the other of the

linkage-arm beads 51, and each of which is arranged for stopping coaction with a respective one of the stop surfaces 57 intermediate of the beads and the one of the two opposing stop surfaces of the second linkage arm, wherein the other of the beads of said second linkage arm is intended for the seat 52 of the first linkage arm, wherein the linkage arms are rotatable simultaneously between the stop surfaces of respective stop parts and herewith between their two limited rotational positions.

The first support part 46 is intended to support against supporting parts of a form element and to be through-passed by a tension element, wherein the support part is preferably displaceable freely along the tension element. The second support part 47 is preferably mounted on the tension element with the aid of screw threads 47' and is held in a given axial position on the tension element by means of said screw threads, wherein a radial hole is preferably provided for a locking screw or the like, not shown.

According to one preferred embodiment, the axle elements and the seats are included in the respective linkage arms and support parts, wherein said linkage arms and support parts with axle elements, etc. are formed integrally. The reference numeral 65 identifies a handle or the like mounted on the second linkage arm by means of which a switch between an expanded and a non-expanded state, and vice versa, can be made.

Figure 17 illustrates a second embodiment of a second fixating element, in which said end-part 4" includes a substantially cylindrical peg 66 having a circumferentially extending locking groove 66' and a part 67

connected axially therewith whose diameter is larger than the diameter of the peg and which carries externally a screw thread 68, which is preferably broken or interrupted in the circumferential direction. The  
5 fixating element also includes a locking sleeve 69 which is mounted on a preferably supporting part of a form element. The locking sleeve, in which said peg is intended to be inserted, includes an internal ball groove 70 extending circumferentially around said  
10 sleeve, and a latching pawl 71 which connects axially therewith and moves circumferentially, wherein two guide rings 72, 73 and at least one (in the present case two) intermediate locking balls 74 are arranged internally of the locking sleeve. The locking sleeve  
15 also includes an internal screw threaded part 79, which is preferably interrupted in the circumferential direction, wherein said guide rings 72, 73, in a first position, are intended to position the ball/balls in said ball groove 70, in which position the peg is not locked  
20 in the locking sleeve, and, in a second position, to position the ball/balls in said locking groove and radially inwardly of the latch, in which position the peg cannot be withdrawn from the locking sleeve, wherein said second position is intended to be taken subsequent to withdrawal of the peg from the locking sleeve  
25 to some extent and subsequent to rotation of the peg relative to the locking sleeve, to some extent.

The reference numeral 76 identifies friction elements,  
30 or sealing elements, which have the form of O-rings arranged between the guide ring 72 located nearest the free end 66 of the peg and said peg or the locking sleeve for axial displacement of the guide ring.

One embodiment of the invention, not shown, includes an array of spacers, preferably in the form of rings, which function to maintain a given distance between form boards, shuttering panels or the like, and which are placed between a supporting part of a form element connecting with an excentric locking device and the supporting part of said excentric locking device facing towards said form element, wherein at a given axial position of the excentric locking device, the distance between the form boards or can be increased and decreased by inserting and removing spacers respectively, said spacer arrangement including a marking which discloses the distance prevailing at that time.

The manner in which the inventive clamping and fixating device works will be understood in all essentials from the foregoing. The excentric locking device enables a switch to be made between the two states of the excentric device in a very gentle and quiet manner, even when the excentric device is under load.

The manner in which the inventive form tie functions will also be understood in all essentials from the foregoing. Thus, the tension element of the tie is intended to be manipulated from one side of the form, and fixation/locking of the tension element can also be achieved from this same side of the form. The tension element is thus passed through holes in the sides of the form, such that the end of the tension element is in contact with a fixating element and can be locked axially thereto, by rotation. The excentric locking device is then activated, which when expanded holds the sides of the form in desired mutual positions. The sealing element is compressed axially by means of spacers, which are preferably rotatable, so as to seal

5 against leakage from the cavity between the form sides. Subsequent to pouring concrete into the form and allowing the concrete to solidify or set, the sealing element is relieved of axial load, therewith causing the sealing element to contract radially and to release its contact with the concrete. Subsequent to bringing the excentric locking device to its non-expanded state, the locking parts can be moved away or to one side in a manner to enable the tension element and the sealing  
10 element to be withdrawn, removed and re-used.

The manner in which the inventive forms operate will also be evident from the foregoing. Alternation between a moulding state and a non-moulding state can be  
15 effected quickly and quietly. The use of wedging arrangements and the drawbacks associated therewith are avoided.

As will be evident from the foregoing, the invention  
20 affords important advantages in comparison with known technology. For instance, the form tie can be mounted very quickly and with precision. The wedge arrangement that requires the frequent use of sledge hammers and like devices is avoided. Sealing and locking of the  
25 tension element is effected simply and very efficiently, thereby enabling the load on both the sealing element and the tension element to be removed in a very simple fashion.

30 The advantages afforded by the inventive clamping and fixating devices and the inventive forms or shuttering will also be evident from the foregoing.

35 Although the invention has been described with reference to a number of exemplifying embodiments, it will

be understood that other embodiments and minor modifications are conceivable within the concept of the invention.

5 For example, the tension element 4 may be constructed in several ways. In the illustrated embodiments, the tension element has essentially the form of a rod. It will be understood, however, that the tension element may consist entirely or partially of a wire, cable or  
10 the like. The end/tip 4" intended for coaction with an insert-type fixating element 6 may be fixed to the tension element, as illustrated in Figures 1 and 3, although it may also be pivotally mounted on said element.

15 The spacer 25 is preferably rotatable such as to take one position in which the sealing element is not subjected to axial compression and another position in which the sealing element is axially compressed.

20 Although Adiprene has been mentioned as an example of the elastomeric material from which the axially compressible sealing element is made, it will be understood that other plastic materials of the polyurethane  
25 type and corresponding materials may be used. In many cases, a material having a large spring constant is desired, i.e. a material which will provide large compression forces at relatively small compression.

30 Furthermore, although not shown, the holes that are left in the concrete by the sealing element and tension element can be filled with a so-called fibre repair rod. The diameter of the rod will preferably be slightly smaller than the diameter of the formed hole and is  
35 intended to be secured in the concrete with mortar

which can be applied by dipping and which is preferably somewhat shorter than the length of the hole, for instance about 2 mm shorter. The repair rod will also have essentially the same diameter as the sealing  
5 element in its radially relaxed state.

The invention shall not therefore be considered limited to the aforescribed and illustrated embodiments thereof, since modifications can be made within the  
10 scope of the following Claims.

Claims

1. A clamping and fixating arrangement primarily intended for concrete forms or shuttering and functioning to hold individual elements, such as form elements, in desired mutual positions, characterized by an excentric locking device which is provided with an expandable excentric part (11) and which has a predetermined axial extension in an expanded state and an axial extension which is smaller than said predetermined axial extension in a non-expanded state.

2. An arrangement according to Claim 1, characterized in that the excentric locking device includes two mutually displaceable support parts (12, 13, 46, 47) by means of which said predetermined axial extension is defined and which are intended to coact with load-carrying parts (10) of said form element, either directly or indirectly.

3. An arrangement according to Claim 1 or 2, characterized by an excentrically expandable linkage-arm arrangement (14) operative in changing the axial extension, or length, of the excentric locking device.

4. An arrangement according to Claim 2 or 3, characterized by support parts, preferably pivotally connected to an excentrically expandable linkage-arm arrangement (14) which in a first position, a non-expanded position, holds the support parts close together, and in a second position, an expanded position, holds the support elements spaced from one another.

5. An arrangement according to Claim 3 or 4,  
c h a r a c t e r i z e d by linkage arms (15, 16)  
which are pivotal about mutually parallel shafts or  
5 axles (17, 18, 18') which extend transversely to the  
expansion direction of the excentric locking device,  
wherein certain linkage arms are connected to an ex-  
centric (19) which is pivotal around a pivot axis which  
extends substantially parallel with the shafts or axles  
10 of said linkage arms, wherein interchange between a  
non-expanded state and an expanded state of the ex-  
centric locking device is effected by rotation of the  
excentric (19).

15 6. An arrangement according to Claim 3 or 4,  
c h a r a c t e r i z e d by two linkage arms (44, 45)  
which are intended for mutual pivotal coaction and to  
pivotally coact with a respective support part (46,  
47), wherein the pivots permit rotation about mutually  
20 parallel pivot shafts or axles (48, 49, 50) which  
extend transversely to the expansion direction of the  
excentric locking device, and wherein each pivot in-  
cludes at least one axle element (51) of partially  
cylindrical configuration, and a seat (52) of partially  
25 cylindrical configuration intended for the axle element  
(51).

7. An arrangement according to Claim 6, c h a r -  
a c t e r i z e d in that the linkage arms (44, 45)  
30 and the support parts (46, 47) include stop surfaces  
which are intended to define a distinct, non-expanded  
position in which each of the linkage arms takes a  
respective first limited rotational position, and stop  
surfaces which are intended to define a distinct,  
35 expanded position in which each of the linkage arms

takes a respective second limited rotation position.

8. An arrangement according to Claim 7, c h a r -  
a c t e r i z e d in that the arrangement includes a  
5 first linkage arm (44) which comprises a corner part  
(53) which extends parallel with said pivot shafts or  
axles (48, 49, 50) and which carries at its extremity a  
bead (51) of partially cylindrical configuration and  
forming an axle element (51), and which corner part  
10 forms a stop surface on either side of said bead, and  
further comprises two stop surfaces (56) opposite said  
bead and separated by a seat (52) of partial cylindri-  
cal configuration; and in that said arrangement further  
includes a second linkage arm (45) which comprises two  
15 beads (51) of partial cylindrical configuration and  
each forming an axle element and being separated by an  
intermediate stop surface (57), and two opposing stop  
surfaces (58, 59) on opposing sides of the two beads in  
relation to said intermediate stop surface (57); and in  
20 that a first support part (46) is provided for coaction  
with said first linkage arm (44) and includes two stop  
surfaces (60, 61) separated by an intermediate seat  
(52) for the bead of the first linkage arm and intended  
for stopping coaction with a respective one of the stop  
25 surfaces (54, 55) located on each side of the bead  
(51); and in that a second support part (47) is provi-  
ded for coaction with said second linkage arm and  
includes two stop surfaces (62, 63) separated by an  
intermediate seat (52) for the one bead of said second  
30 linkage arm and intended for stopping coaction with a  
respective one of the stop surface (57) intermediate of  
the beads and one of the two opposing stop surfaces  
(58, 59) of the second linkage arm, wherein the other  
bead of the second linkage arm is intended for the seat  
35 (52) of the first linkage arm, and wherein the linkage

arms are rotatable simultaneously between the stop surfaces of respective support parts.

5 9. An arrangement according to Claim 6, 7 or 8, characterized in that the axle elements and the seats are included in respective linkage arms and support parts, wherein each of said axle elements and seats are formed integrally in a one piece structure.

10 10. A form tie intended primarily for concrete forms and intended for holding a form comprising opposing form bottoms provided with form boards in a desired position, wherein concrete is cast against said form boards and wherein said form includes at least one  
15 tension element which extends between opposing form boards and two tension-element fixation or securing elements externally of the panels, and a sealing element in which the tension element is intended to pass  
20 between the panels and which is intended to seal against two opposing holes in said panels, said tension element extending through said holes, characterized by a first fixating element (5) which includes an excentric locking device having an expandable excentric part (11) and intended, in an expanded  
25 locking state, to provide a predetermined greatest distance between the form boards (2) and to transmit tension forces acting in the tension element in the form of compression forces to the form bottom (1) at  
30 which the excentric locking device is arranged.

11. A form tie according to Claim 10, characterized in that the excentric locking device includes a first support part (12, 46) which is intended to support against load-bearing parts (10), such  
35

as form-column or form-joist parts (10) of the form bottom (1), and a second support part (13, 47) which is intended to take a given axial position relative to the tension element (4), so that a tension force can be applied to the tension element, said support parts being pivotally connected to an excentrically expandable linkage-arm arrangement (14) which functions, in a first position, a non-expanded position, to hold the support parts close together in the longitudinal direction of the tension element, said tension element being preferably relieved of load at this stage, and in a second position, an extended position, function to hold the support parts separated from one another in the longitudinal direction of the tension element, wherein the tension element may be subjected to a tensile force.

12. A form tie according to Claim 10 or 11, characterized by linkage arms (15, 16) which are pivotally mounted on mutually parallel shafts or axles (17, 18, 18') which extend transversely to the longitudinal direction of the tension element; in that certain linkage arms are connected to an excentric (19) which is pivotal about a pivot shaft which extends substantially parallel with the shafts or axles of said linkage arms, wherein the excentric locking device can be switched between a non-expanded state and an expanded state by rotation of said excentric.

13. A form tie according to Claim 10 or 11, characterized by two linkage arms (44, 45) which are intended for mutually pivotal coaction and for pivotal coaction with a respective support part (46, 47) where the pivots permit rotation around mutually parallel pivot shafts or axles (48, 49, 50) which

5 extend transversely to the expansion direction of the excentric locking device, and where each pivot includes at least one axle element (51) of partially cylindrical configuration and a seat (52) of partial cylindrical configuration and intended for said axle element (51).

10 14. A form tie according to Claim 12 or 13, characterized in that both the respective support parts and the linkage-arm arrangement have parts located on both sides of the longitudinal direction of the tension element (4).

15 15. A form tie according to Claim 10, 11, 12, 13 or 14, characterized in that part of the excentric locking device can be moved away from the tension element (4) so as to enable said element to be withdrawn and removed.

20 16. A form tie according to Claim 10, 11, 12, 13, 14 or 15, characterized in that end (4') of the tension element (4) intended for coaction with the excentric locking device is provided with a stop-part (21) which can be moved in the longitudinal direction of the tension element and which is intended for applying tension force to said element.

30 17. A form tie according to Claim 10, 11, 12, 13, 14, 15 or 16, characterized by a second fixating element (6) which is intended to detachably coact with an end-part (4") of the tension element opposite said excentric locking device such as to maintain a tension force in the tension element, wherein the tension element is preferably arranged to be brought into coaction with the fixating element (6) by  
35 rotation.

18. A form tie according to Claim 17, c h a r a c -  
t e r i z e d in that said end-part (4") includes a  
part (23) of elongated, such as oval or rectangular,  
5 cross-sectional shape transversely to the longitudinal  
direction of the tension element, and in that a cor-  
responding fixation element (6) includes an elongated  
hole (24) into which the elongated part (23) can be  
inserted in a given position of rotation and from which  
10 said elongated part cannot be withdrawn in another  
position of rotation.

19. A form tie according to Claim 17, c h a r a c -  
t e r i z e d in that said end-part (4") is screw  
15 threaded, and in that the fixation element includes a  
corresponding nut means.

20. A form tie according to Claim 17, 18 or 19,  
c h a r a c t e r i z e d in that at least said end-  
20 part (4") includes a rod-like part having opposing cam  
parts which form an elongated, oval, cross-sectional  
configuration and also a screw-thread configuration;  
and in that a corresponding fixation element (6) in-  
cludes an elongated hole having an internal screw  
25 thread, so that the part of elongated cross-sectional  
configuration can be inserted into the elongated hole  
(24) in a given position of rotation whereas said part  
cannot be withdrawn from said elongated hole (24) under  
mutual coaction of the screw threads in another posi-  
30 tion of rotation.

21. A form tie according to Claim 17, 18 or 19,  
c h a r a c t e r i z e d in that said end-part (4")  
includes a substantially cylindrical peg (66) which is  
35 provided with a circumferentially extending locking

groove (66'), and a part (67) connected to said peg and having a greater diameter than the peg and which carries external screw threads (68), which are preferably interrupted in the circumferential direction; and by a locking sleeve (69) which as fixating element (6) is intended for arrangement adjacent a form element and in which said peg is intended to be inserted and which includes an internal, circumferentially extending ball groove (70), a latching pawl (71) connecting therewith, wherein two guide rings (72, 73) and at least one intermediate locking ball (74) are arranged internally in relation to the locking sleeve, and an internal screw threaded part (75) which is preferably interrupted in the circumferential direction, and wherein said guide rings are intended, in a first position, to position the ball or balls (74) in said ball groove (70), said peg being locked in the locking sleeve in said position, and, in another position, to position the ball or balls (74) in said locking groove (66') and, radially, inwardly of said latching pawl (71), in which position the peg cannot be withdrawn from the locking sleeve, wherein said second position is taken subsequent to withdrawing the peg to a given extent from the locking sleeve and subsequent to rotation of the peg in relation to said sleeve to some extent.

22. A form tie according to Claim 21, characterized by friction element (76), preferably in the form of O-rings, arranged between at least the guide rings (72) located nearest the free end (66") of the peg (66) and the peg and locking sleeve respectively for axial displacement of said guide ring.

23. A form tie according to Claim 17, 18, 19, 20, 21 or 22, characterized in that the end-part

(4") intended for coaction with the second fixation element (8) is pivotally mounted on the remaining part of the tension element.

5 24. A form tie according to Claim 10, 11, 12, 13, 14, 15, 16, 17, 18, 19, 20, 21, 22 or 23, c h a r a c -  
t e r i z e d in that the sealing element (7) is  
intended for sealing coaction with the mutually oppos-  
ing holes (8, 9) in the form boards (2) under axial  
10 compression.

15 25. A form tie according to Claim 24, c h a r a c -  
t e r i z e d by a spacer element (25) arranged be-  
tween an external part (10), such as a load-bearing  
part (10) of a form bottom (1) and an end-part (7') of  
the sealing element, said spacer element functioning to  
axially compress the sealing element.

20 26. A form tie according to Claim 25, c h a r a c -  
t e r i z e d in that the spacer element (25) is  
mounted externally of the same form bottom (1) as the  
excentric locking device and extends between a load-  
bearing part (10) of the form bottom and a part (7') of  
the sealing element which protrudes outwardly from the  
25 hole (9) in the form side remote from the excentric  
locking device.

30 27. A form tie according to Claim 25 or 26, c h a r -  
a c t e r i z e d in that the spacer element (25) is  
pivotally mounted and is arranged so that it can be  
rotated to a position in which the sealing element is  
not subjected to axial compression and to a position in  
which the sealing element is subjected to axial com-  
pression.  
35

28. A form tie according to Claim 24, 25, 26 or 27, characterized in that one end (7') of the sealing element is intended to cover one (8) of said holes internally of a form board (2) and is intended to be pressed axially against those parts of the form board (2) which define the periphery of said hole so as to effect a seal.
29. A form tie according to Claim 28, characterized in that the end (7") of the sealing element remote from the excentric locking device covers said hole.
30. A form tie according to Claim 10, 11, 12, 13, 14, 15, 16, 17, 18, 19, 20, 21, 22, 23, 24, 25, 26, 27, 28 or 29, characterized in that the tension element extends in a support tube (30), at least between the form sides (2).
31. A form tie according to Claim 10, 11, 12, 13, 14, 15, 16, 17, 18, 19, 20, 21, 22, 23, 24, 25, 26, 27, 28, 29 or 30, characterized in that the sealing element (7) substantially comprises a sleeve (26) made of elastomeric material, such as an elastic plastic material, a rubber-based material or the like, intended for pronounced compression in an axial direction.
32. A form tie according to Claim 10, 11, 12, 13, 14, 15, 16, 17, 18, 19, 20, 21, 22, 23, 24, 25, 26, 27, 28, 29, 30 or 31, characterized in that the sealing element (7) includes elastic parts (27, 28) for coaction with said holes (8), said parts being intended for pronounced axial compression and being carried by

intermediate parts (29) which are not intended to be compressed to any substantial degree.

5 33. A form tie according to Claim 10, 11, 12, 13, 14, 15, 16, 17, 18, 19, 20, 21, 22, 23, 24, 25, 26, 27, 28, 29, 30, 31 or 32, characterized in that the parts (26, 27, 28) of the sealing element (7) intended for axial compression are made of Adiprene or some similar material which will not fasten substantially to concrete coming into contact with the sealing  
10 element.

15 34. A form tie according to Claim 10, 11, 12, 13, 14, 15, 16, 17, 18, 19, 20, 21, 22, 23, 24, 25, 26, 27, 28, 29, 30, 31, 32 or 33, characterized in that the parts (29) of the sealing element which are not intended for compression are made of Robalon or some similar material and are of substantially conical shape, thereby to facilitate withdrawal upon completion  
20 of a casting operation.

25 35. A form tie according to Claim 1, 11, 12, 13, 14, 15, 16, 17, 18, 19, 20, 21, 22, 23, 24, 25, 26, 27, 28, 29, 30, 31, 32, 33 or 34, characterized in that subsequent to completion of a casting operation, said sealing element and tension element are intended to be replaced with a repair rod of fibre concrete which functions to repair the hole left by said two elements in the cast concrete.

30 36. A form tie according to Claim 35, characterized in that the repair rod has a diameter which is slightly smaller than the diameter of the formed hole and is intended to be secured in the concrete with mortar which can be applied by dipping and  
35

which is preferably somewhat shorter than the length of the hole, for instance about 2 mm shorter.

5 37. A form tie according to Claim 35 or 36, in which the sealing element is expandable in a radial direction, c h a r a c t e r i z e d in that the repair rod has essentially the same diameter as the diameter of the sealing element when said element is in a radially relaxed state.

10 38. A form primarily intended for casting concrete and including at least two form elements which are held fixated in relation to one another by means of clamping and fixating arrangements during a casting operation,  
15 c h a r a c t e r i z e d in that said clamping and fixating arrangements include an excentric locking device which is provided with an expandable excentric part (11) and which, in an expanded state, has a predetermined axial extension or length and, in a non-expanded state, has an axial extension or length which is  
20 smaller than said predetermined length.

25 39. A form according to Claim 38, c h a r a c - t e r i z e d in that the excentric locking device includes two mutually displaceable supports parts (12, 13, 46, 47) by means of which said predetermined length is defined and which support parts are intended to coact with load-bearing parts (10) of said form element, either directly or indirectly.

30 40. A form according to Claim 38, c h a r a c - t e r i z e d by an excentrically expandable linkage-arm arrangement (14) which functions to change the length of the excentric locking device.

41. A mould according to Claim 38, 39 or 40, in which at least two form elements in the form of form bottoms (1) are arranged sequentially in a line and against which casting is intended to take place, c h a r a c -  
5 t e r i z e d in that said form bottoms (1) are held clamped together and fixated in relation to one another at a joint (35) by means of at least one excentric locking device in its expanded state, wherein the form bottoms include fittings (36, 37) against which the  
10 excentric locking device is intended to act in a manner to pull the form bottoms towards one another.

42. A form according to Claim 38, 39 or 40, in which at least two form elements are provided for forming a  
15 window opening, door opening or the like, or a so-called internal form for the construction of a hoist shaft, a stairway shaft or a ventilation shaft, for instance, and in that said at least two form elements are held at a predetermined distance from one another  
20 such as to define an opening of predetermined width, or a shaft of desired cross-sectional shape, wherein concrete is cast externally against said form elements, c h a r a c t e r i z e d in that the form elements (38) are held at a predetermined distance apart by  
25 means of at least one excentric locking device in its expanded state, wherein the form elements include fittings (39) against which the excentric locking device is intended to act.

43. A form according to Claim 42, which functions as a  
30 window-opening or door-opening form, c h a r a c - t e r i z e d in that two form elements (38) in the form of essentially E-shaped frame elements are arranged mutually opposite one another; and in that said  
35 form elements are held apart by means of three excen-

tric locking devices, of which one excentric locking device is arranged to act between each pair of opposing horozintal element parts (40).

5 44. A form according to Claim 42, which functions as  
an internal form, c h a r a c t e r i z e d by two  
opposing form elements, each comprising two side parts  
and an intermediate part, said parts having a brace-  
like or a clip-like cross-sectional shape, and in that  
10 the form elements are held at a predetermined distance  
apart by at least two excentric locking devices in  
their expanded states, where one excentric locking  
device is intended to act between each pair of mutually  
opposing side-parts.

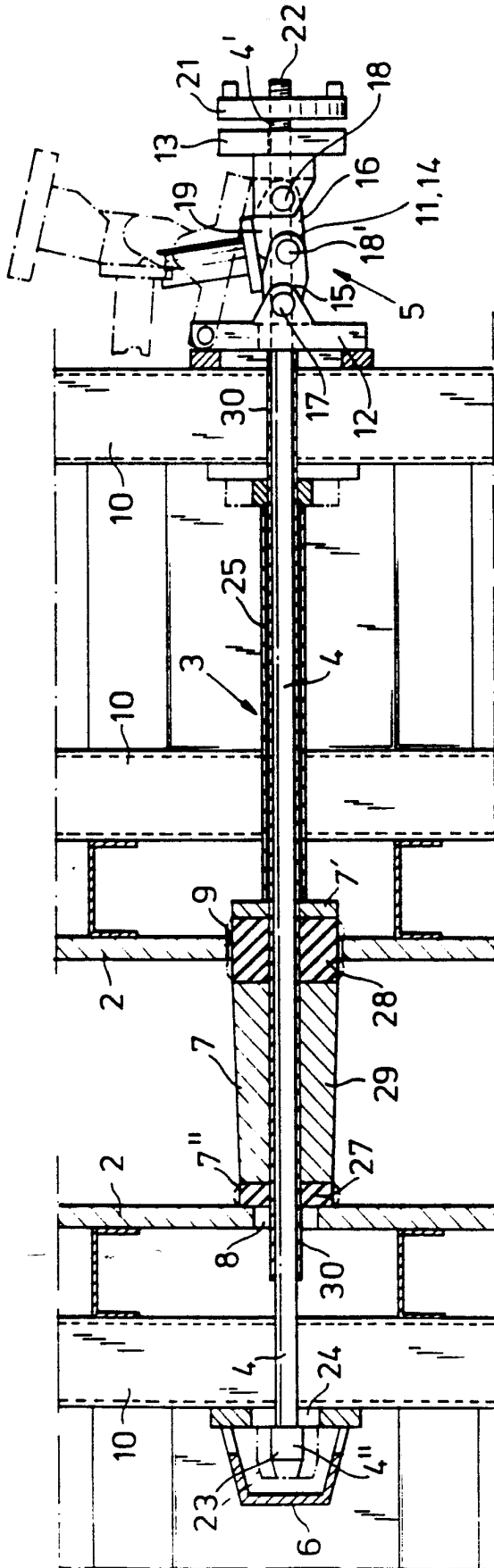

Fig. 1

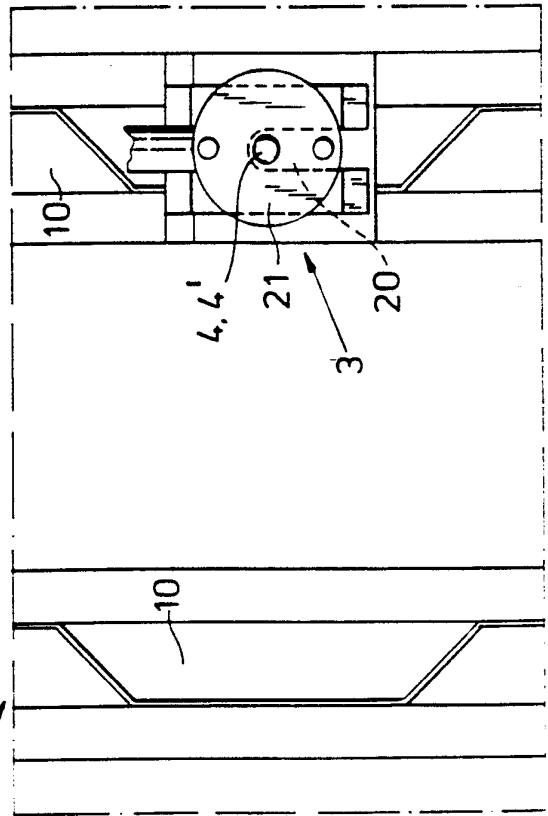

Fig. 2

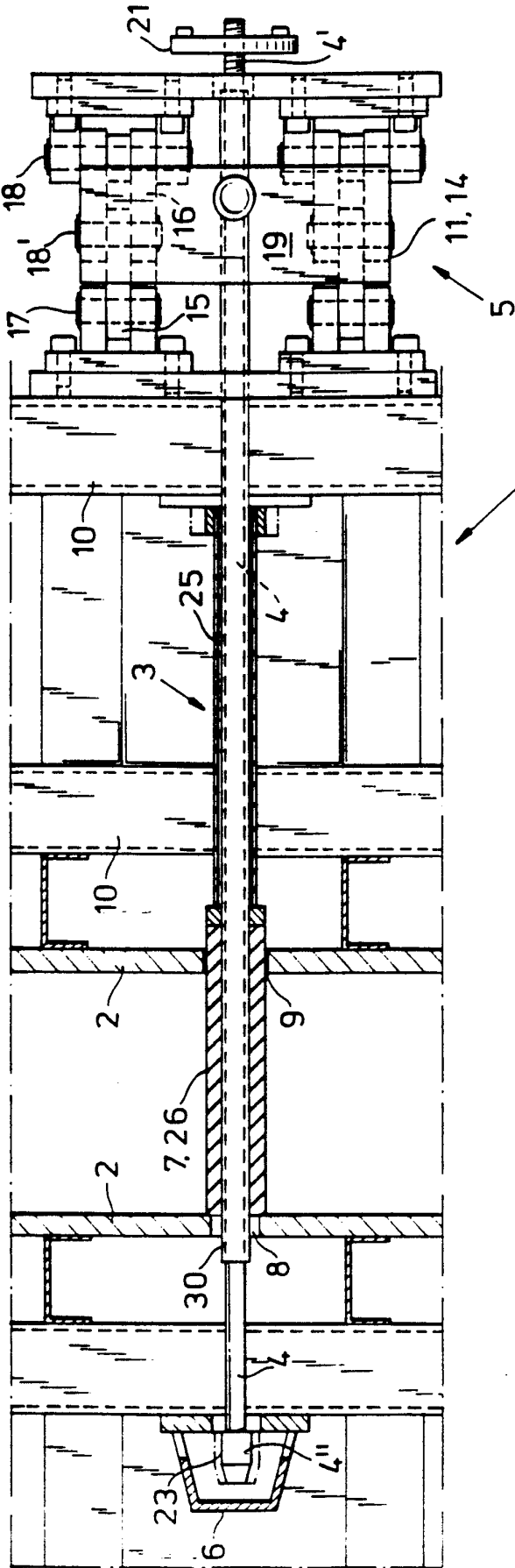

Fig. 3

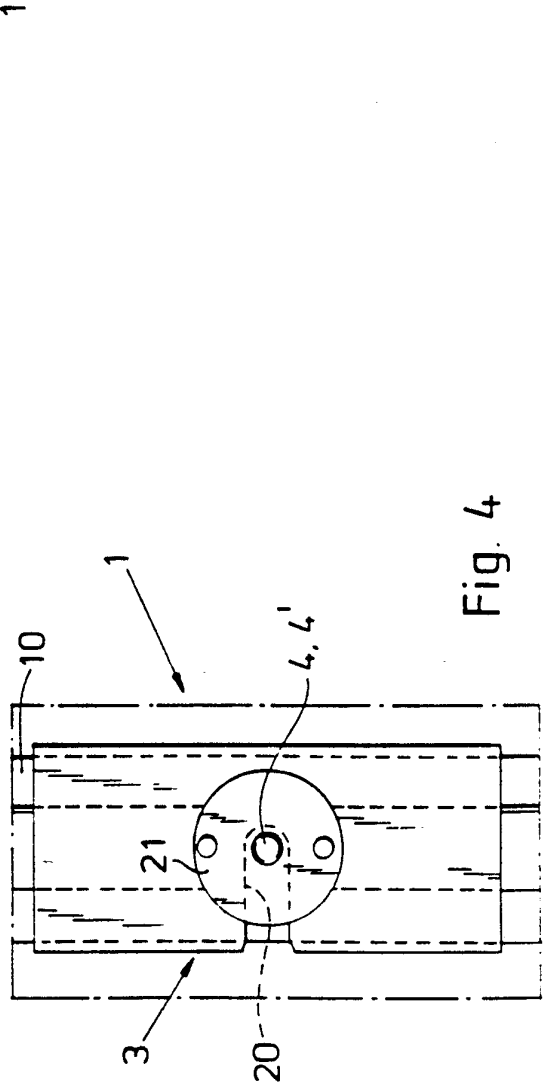

Fig. 4

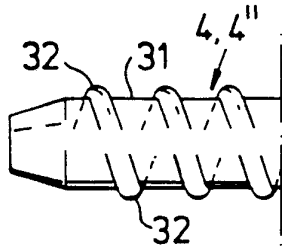

Fig. 5

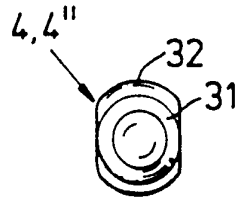

Fig. 6

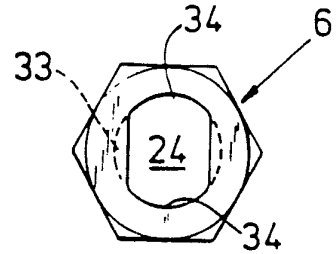

Fig. 7

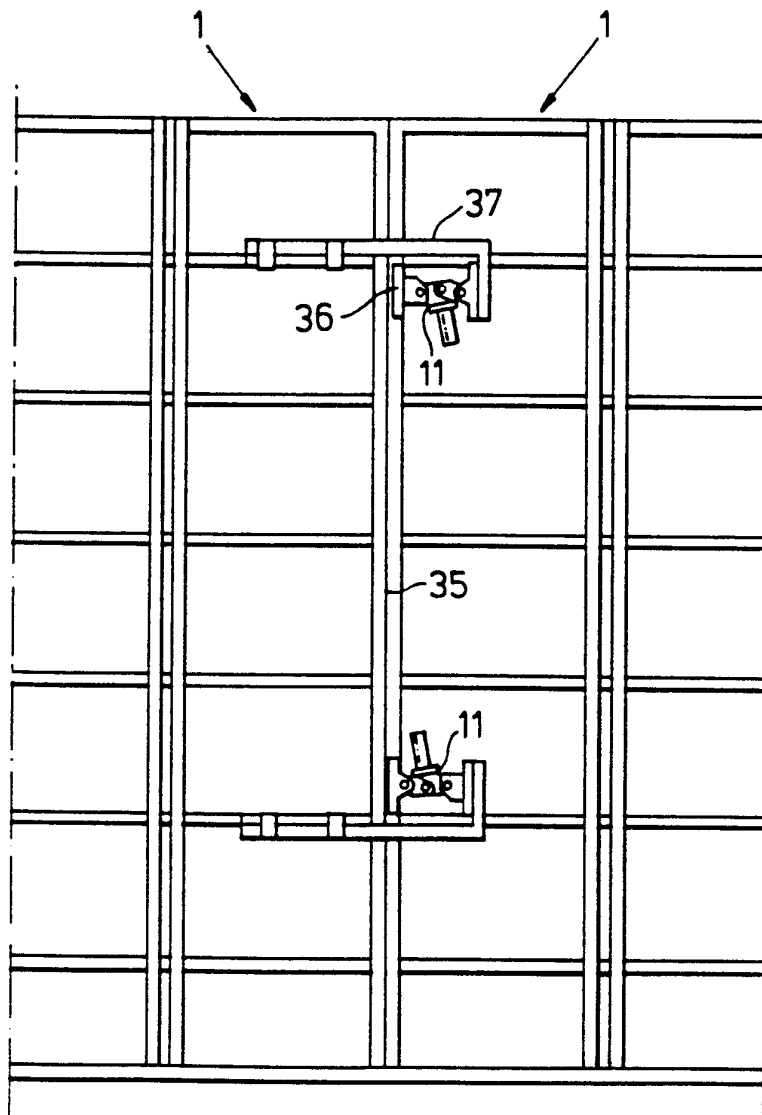

Fig. 8

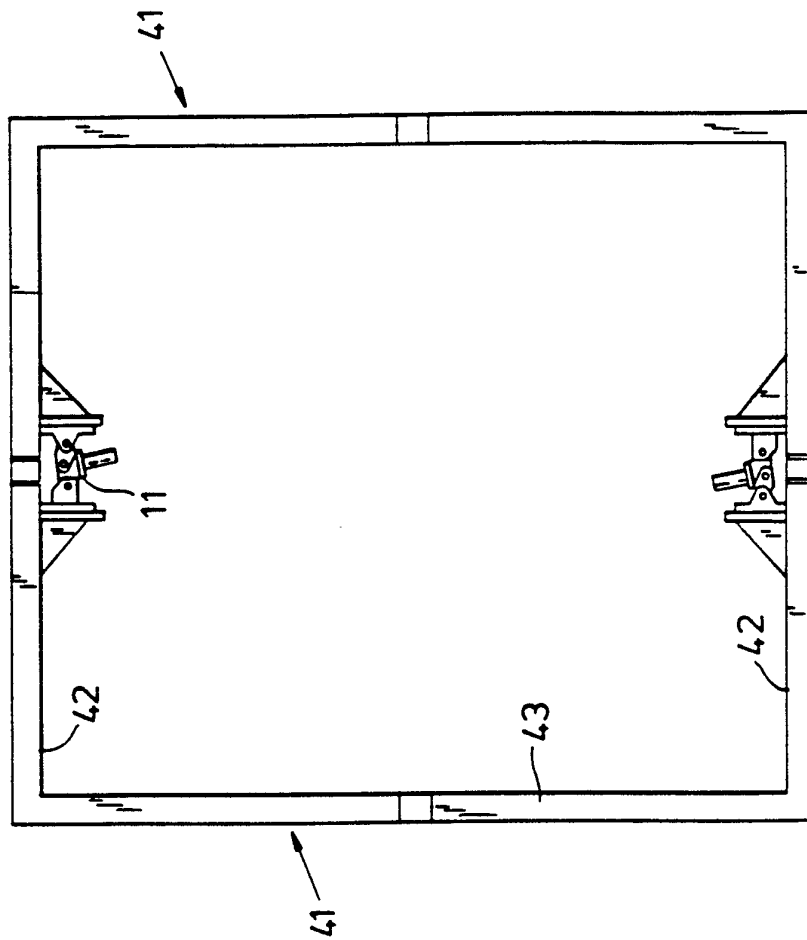

Fig. 9

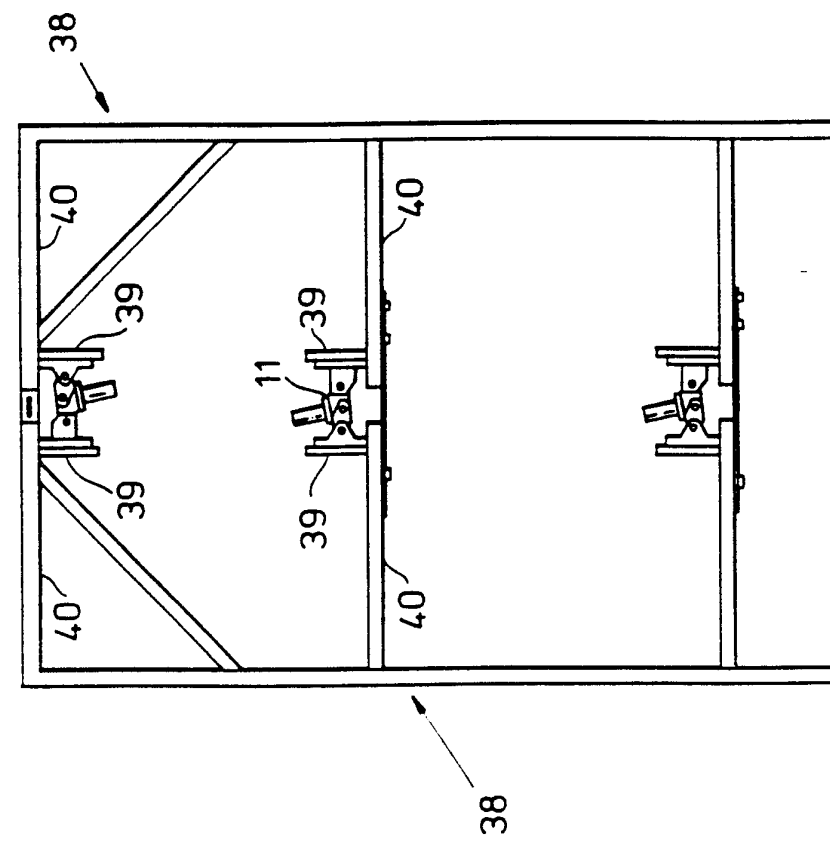

Fig. 10

5/5

Fig. 11

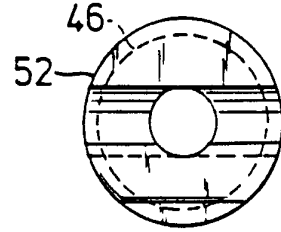
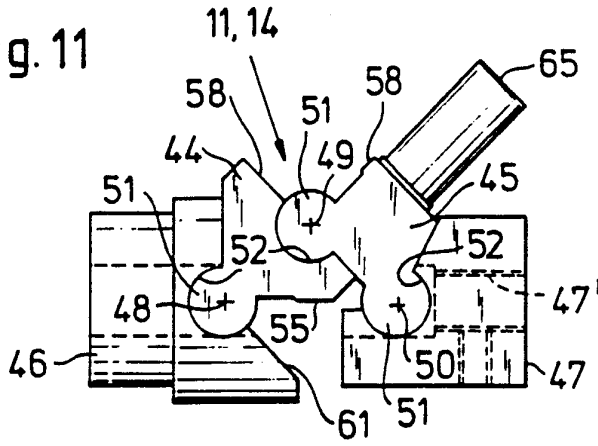

Fig. 13

Fig. 12

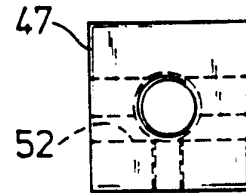
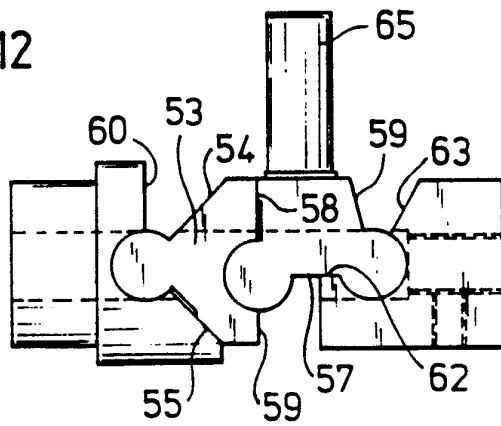

Fig. 14

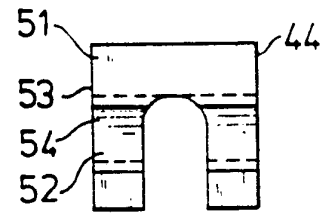

Fig. 15

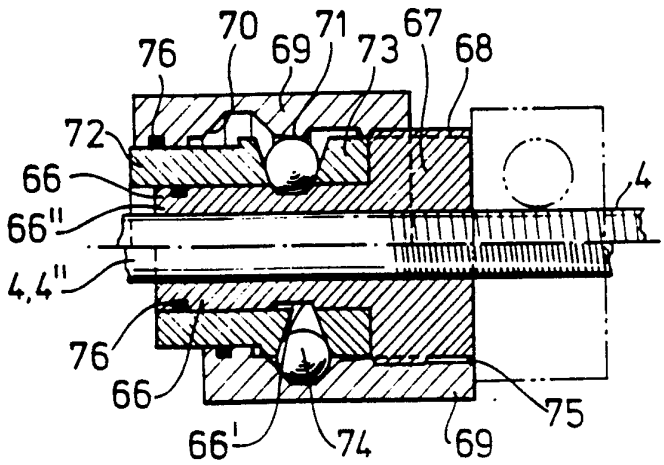

Fig. 17

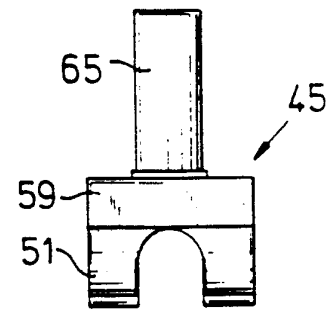



Fig. 16

# INTERNATIONAL SEARCH REPORT

International Application No PCT/SE 92/00015

<b>I. CLASSIFICATION OF SUBJECT MATTER</b> (if several classification symbols apply, indicate all) <sup>6</sup>		
According to international Patent Classification (IPC) or to both National Classification and IPC		
IPC5: E 04 G 17/075		
<b>II. FIELDS SEARCHED</b>		
Minimum Documentation Searched <sup>7</sup>		
Classification System	Classification Symbols	
IPC5	E 04 G	
Documentation Searched other than Minimum Documentation to the Extent that such Documents are Included in Fields Searched <sup>8</sup>		
SE,DK,FI,NO classes as above		
<b>III. DOCUMENTS CONSIDERED TO BE RELEVANT<sup>9</sup></b>		
Category *	Citation of Document, <sup>11</sup> with indication, where appropriate, of the relevant passages <sup>12</sup>	Relevant to Claim No. <sup>13</sup>
A	US, A, 1732259 (S.S. COLT) 22 October 1929, see the whole document ---	1-44
A	SE, A, 8405045 (M. LUNDFELDT-AXDAL) 9 April 1986, see the whole document --- -----	1-44
<p>* Special categories of cited documents: <sup>10</sup></p> <p>"A" document defining the general state of the art which is not considered to be of particular relevance</p> <p>"E" earlier document but published on or after the international filing date</p> <p>"L" document which may throw doubts on priority claim(s) or which is cited to establish the publication date of another citation or other special reason (as specified)</p> <p>"O" document referring to an oral disclosure, use, exhibition or other means</p> <p>"P" document published prior to the international filing date but later than the priority date claimed</p> <p>"T" later document published after the international filing date or priority date and not in conflict with the application but cited to understand the principle or theory underlying the invention</p> <p>"X" document of particular relevance, the claimed invention cannot be considered novel or cannot be considered to involve an inventive step</p> <p>"Y" document of particular relevance, the claimed invention cannot be considered to involve an inventive step when the document is combined with one or more other such documents, such combination being obvious to a person skilled in the art.</p> <p>"&amp;" document member of the same patent family</p>		
<b>IV. CERTIFICATION</b>		
Date of the Actual Completion of the International Search	Date of Mailing of this International Search Report	
24th March 1992	1992 -03- 27	
International Searching Authority	Signature of Authorized Officer	
SWEDISH PATENT OFFICE	Åke Olofsson 	

**ANNEX TO THE INTERNATIONAL SEARCH REPORT  
ON INTERNATIONAL PATENT APPLICATION NO.PCT/SE 92/00015**

This annex lists the patent family members relating to the patent documents cited in the above-mentioned international search report.  
The members are as contained in the Swedish Patent Office EDP file on **28/02/92**  
The Swedish Patent Office is in no way liable for these particulars which are merely given for the purpose of information.

Patent document cited in search report	Publication date	Patent family member(s)	Publication date
US-A- 1732259	29-10-22	NONE	
SE-A- 8405045	86-04-09	NONE	