

(No Model.)

2 Sheets—Sheet 1.

A. E. DEWEESE. GRAIN CARRIER.

No. 604,822.

Patented May 31, 1898.

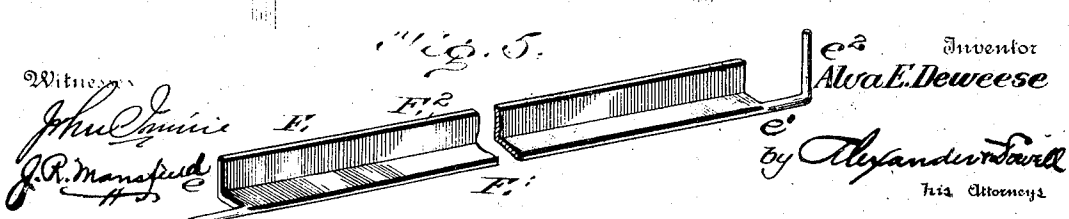
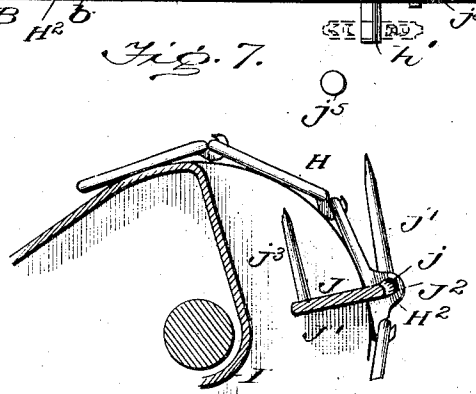
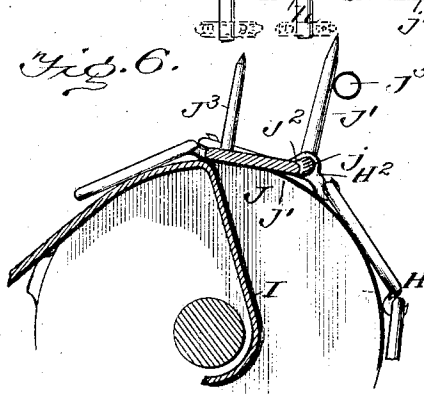
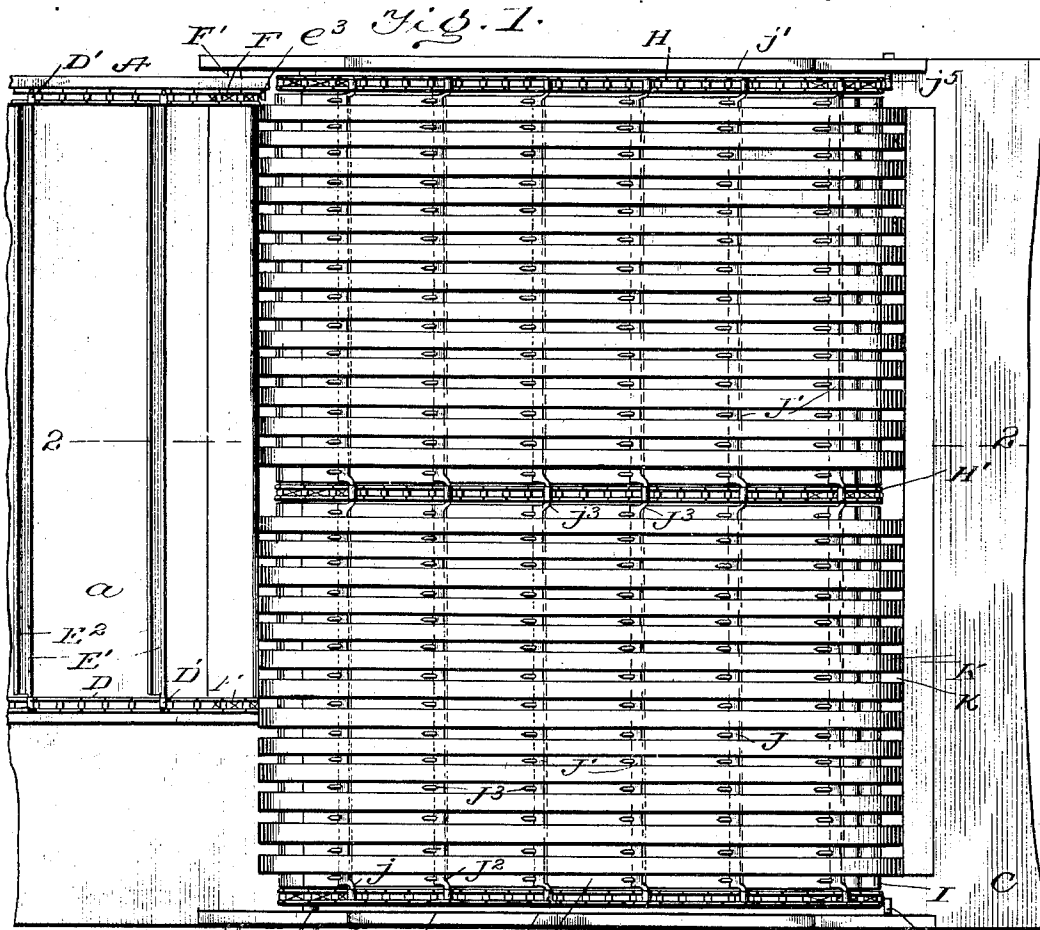

Witness
John Camie
J. R. Mansfield

(No Model.)

2 Sheets—Sheet 2.

A. E. DEWEESE.
GRAIN CARRIER.

No. 604,822.

Patented May 31, 1898.

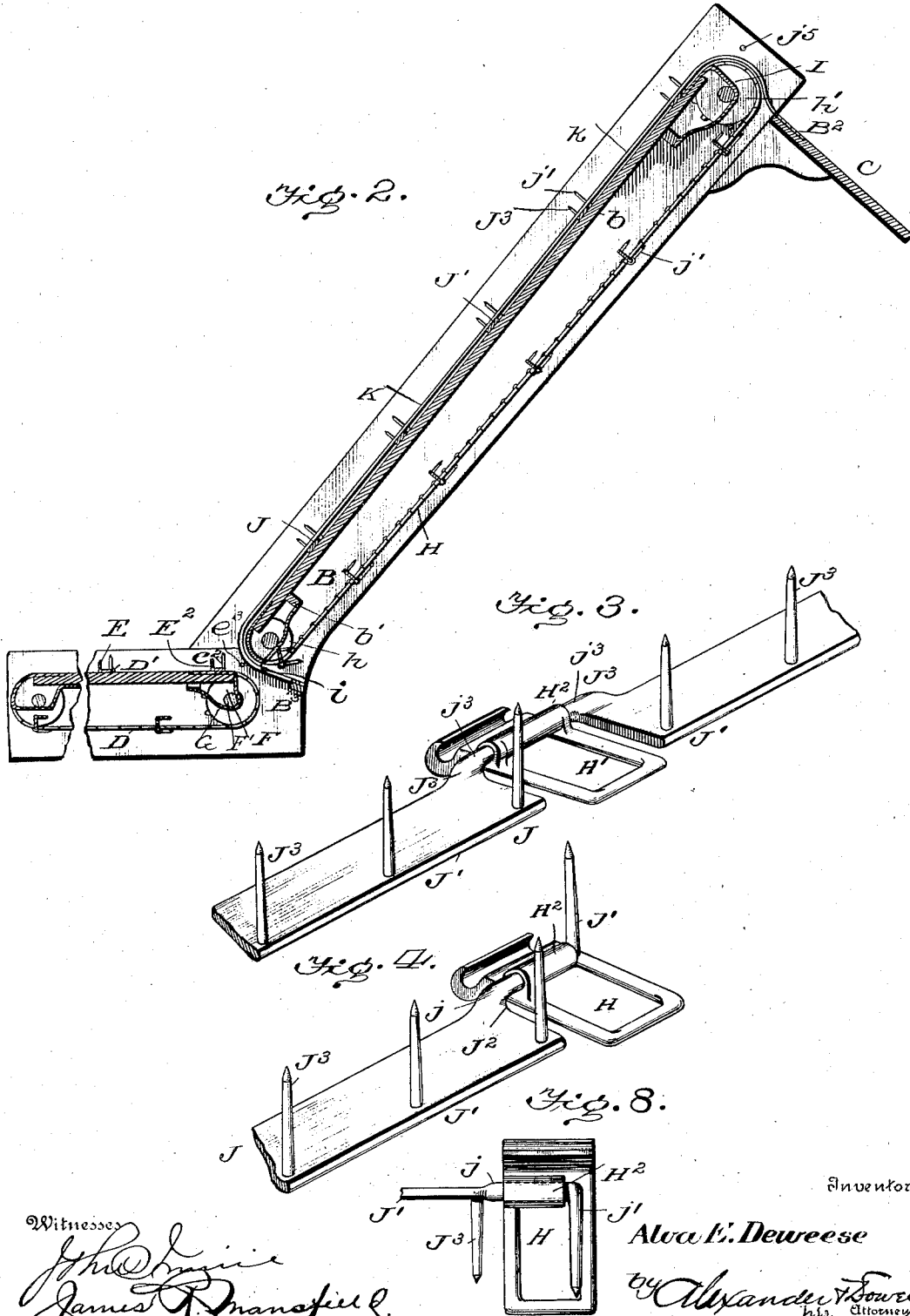

UNITED STATES PATENT OFFICE.

ALVA E. DEWEESE, OF QUINCY, OHIO.

GRAIN-CARRIER.

SPECIFICATION forming part of Letters Patent No. 604,822, dated May 31, 1898.

Application filed April 1, 1897. Serial No. 630,297. (No model.)

To all whom it may concern:

Be it known that I, ALVA E. DEWEESE, of Quincy, in the county of Logan and State of Ohio, have invented certain new and useful
5 Improvements in Grain-Carriers; and I hereby declare that the following is a full, clear, and exact description thereof, reference being had to the accompanying drawings, which form part of this specification.

10 This invention is an improvement in straw-carriers for self binding or bundling mowing-machines and is also applicable to other machines or for other purposes. Its object is to provide an endless carrier with bars or rakes,
15 which will move the straw, &c., along to the point of discharge, at which point the forks or bars are shifted automatically, so as to clear themselves of the straw and not catch or drag any of it backward, thus preventing
20 clogging of the machine. I am aware that there have been various forms of carriers devised with this object in view; and my invention therefore consists in the novel construction and combination of parts hereinafter described and claimed, and illustrated in the
25 drawings, in which—

Figure 1 is a top plan view illustrating parts of the upper and lower sections of the carrier, the parts of the carrier proper being shown
30 disproportionately large for the purpose of clearness of illustration. Fig. 2 is a longitudinal vertical section on line 2 2, Fig. 1. Figs. 3 and 4 are detail perspectives of one of the toothed rakes of the upper section and
35 its hinge connection with the sprocket-chain. Fig. 5 is a detail perspective of one of the angle-bar rakes of the lower section. Figs. 6 and 7 are enlarged diagrams showing how the rakes are withdrawn from the straw at the
40 discharge end. Fig. 8 is a detail top view of a rake tilted.

Referring to said drawings, A designates the platform or lower section of the conveyer of a self-binding mowing-machine, for example,
45 upon which the wheat-stalks, straw, &c., falls as cut and by which the said straw is carried back to the foot of the upwardly-inclined conveyer-section B, which catches the straw and carries it up and delivers it onto
50 the bundle-board C.

The section A has an endless carrier com-

posed of side sprocket-chains D and transverse rake-bars E, Fig. 5, which is L-shaped in cross-section, so that when one side E' lies flat on the floor *a* of the section the other side E² stands vertical thereto and forms a transverse rake. This L-shaped rake-bar can be made quite light, while retaining sufficient stiffness to work effectively. The rake-bars E are provided with hinge-studs *e e'* on the ends and on the front edge of part E', which studs are journaled in journal-brackets D', attached to opposite links of the sprocket-chains D or journaled directly in such links, so that the rake-bars will be drawn along the lower section, as in ordinary carrier construction. The end of stud *e'* is bent upward at right angles perpendicular to part E', forming a trip-finger *e²*, for the purpose hereinafter explained.

The chains D run over sprockets F, mounted on shaft F' at each end of the section A.

To the floor *a* at the inner end of the platform is attached a sheet-metal plate G, which is bent down close to shaft F', as shown, and fastened to the under side of the platform, and at proper points adjoining said sheet and above shaft F' pins *e³* are secured to the side board of the section in position to be struck by the fingers *e²* on the rake-bars E just as these bars come directly over the shaft F'. Then as the bars turn down to pass around the shaft-fingers *e²* strike pins *e³*, and the rake-bars are thereby tilted backward, so that the parts E² slip from behind the straw, as indicated in the drawings, and let it drop freely onto the endless conveyer of section B, as indicated in the drawings. It will be observed that the part E² of the rake-bar, at the discharge end, instead of sweeping around the sprockets like a fan-blade feathers and drops down (turning slightly rearward on its pivots as it does so) so as to entirely clear the straw, and then as it passes back to the outer end and strikes the sheet metal it swings by gravity into proper position to rake as it rises up on the platform *a*.

The section B is constructed slightly different from section A; but like said section it has an endless carrier consisting of sprocket-chains H, running over sprocket-wheels *h* on shafts *h'* at each end of the carrier, and a

platform *b*, extending from one shaft to the other about in the plane of the upper portions of the sprocket-chains.

To the upper end of platform *b* is attached one edge of a sheet-metal plate *I*, which is bent short down under shaft *h'* and its lower edge made fast to the bottom of the platform *a* below the shaft, as shown. To the lower end of the platform *b* is attached the edge of a sheet-metal plate *i*, which is curved around on a radius equal to the circumference of the sprockets *h* on the lower shaft *h'*, and its other edge is bent upward and fastened to a bar *b'* on the bottom of the platform, as shown, slightly in advance of or above the lower shaft *h'*.

The rakes *J* of the upper conveyer are of peculiar construction and are made in sections, as shown, two being employed, the inner ends of the sections being pivoted to an intermediate sprocket-chain *H'*, running over sprockets *h* on shafts *h'* like the chains *H*.

Each section *J'* of the upper conveyer-rakes consists of a metal bar having at its outer end a narrow forward projection or shoulder *J²*, from which projects outwardly, parallel with the section, a pivot-pin *j*, which is journaled in a suitably-formed link of the chain *H* or in a journal-bracket *H²*, attached thereto, as shown. The outer end of pin *j* is bent up at right angles thereto and perpendicular to the broad face of bar *J'* into a trip-finger *j'*, hereinafter referred to.

The inner end of each section *J'* is likewise provided with a shoulder *J³* on its front edge, having a journal-pin *j³* projecting therefrom axially in line with pin *j* and journaled in a suitably-formed link or chain *H'* or in a bracket attached thereto, as shown.

The sections *J* are provided with a series of short upstanding teeth *J³* at regular intervals apart, which teeth project up through longitudinal slots *k* in a sheet-metal plate *K*, overlying the platform *b*, while the sections *J'* of the bars pass between said plate and the platform, as shown. The ends of plate *K* are fastened to bars *B²B³* at the upper and lower ends of section *B*, so as to be out of the way, as indicated in the drawings, or in other convenient manner.

To the side boards of section *B*, at proper points adjoining upper shaft *h'*, are secured studs *j⁵*, in position to engage fingers *j'* and trip the rakes *J* backward just as they reach the top of the section. This causes the teeth *J³* of the rakes to withdraw themselves backwardly from the straw, so as to free the latter wholly and let it all drop onto the bundle-boards, the withdrawal of teeth *J³* from the straw being accomplished similarly to the withdrawal of the rake-bars *E* therefrom, and the clearing of the straw being facilitated by the slotted plate *K*. This plate *K* may be made of a series of strips, if desired.

By reference to Fig. 7 it will be seen that the teeth *J³* drop backward out of the straw, keeping close to plate *I* and passing down un-

der the under side of the platform *b* in a partly-turned position different from that they would have if the bars were fixed on the sprocket-chains, and yet not turned completely over. In short, the natural rotation of the bars and teeth with the sprocket-chains as they pass over the upper shaft *h'* is arrested and not completed until after they have passed below said shaft. As shown, the bars *J* are not rotated into position to bring their teeth properly uppermost until they pass under plate *i*, which compels them to rotate in their bearings into proper position.

Having thus described my invention, what I therefore claim as new, and desire to secure by Letters Patent thereon, is—

1. In an endless conveyer, the combination of the platform, sprocket-wheels at the ends thereof, endless chains arranged to move rake-bars over the platform and return them under the platform; the *L*-bars having hinge-studs *e, e'*, on their ends journaled on the chains substantially as described, said studs having upstanding trip-fingers *e²* on their ends; with a stationary pin at the discharge end of the conveyer adapted to engage the trip-fingers on the rake-bars and cause the bars to partly turn on their hinges as they pass over the discharge end of the platform and thus withdraw from the straw, and a guard-plate for turning the rake-bars to natural position at the front or grainward end of the platform, all substantially as and for the purpose described.

2. In an endless conveyer, the combination of the platform, the endless carriers running up over the platform and back thereunder, rake-bars *J* having upstanding teeth *J³* at their rear edge, and journal-pins *j* on their front edge at each end, by which they are hinged on said carriers, and also upstanding tripping-fingers *j'* on the ends of pins *j*; with fixed studs at the discharge end of the conveyer adapted to engage said trip-fingers and cause the rake-bars to partly turn downward and backward and withdraw from the straw, &c., on the conveyer as they pass over the discharge end thereof; and means for throwing said rake-bars into their natural position before they reach the working-point, all substantially as and for the purpose described.

3. In an endless conveyer, the combination of the endless side chains *H* and intermediate endless chain *H'* having links provided with journal-bearings; and the sectional rake-bars *J'* having pins *j³* on their inner ends journaled in chain *H'*, and pins *j* on their outer ends journaled in a chain *H*, said pins *j* having trip-fingers *j'* on their outer ends; with stationary studs at the discharge end of the conveyer adapted to engage said trip-fingers and cause the rake-bars to tilt rearwardly and thus withdraw from the straw, &c., all substantially as and for the purpose described.

4. In a conveyer the combination of the board *b*, the endless side sprocket-chains and

endless intermediate sprocket-chain running over said board, and the sprocket-wheels, and shafts at each end of the board, the curved plate I at the discharge end of the conveyer; the sectional rake-bars J having pivot-pins j , and j^3 by which they are hinged to said side and intermediate sprocket-chains respectively and provided with tripping-fingers j' on their outer ends; with the fixed studs j^5 secured to the side boards and adapted to engage fingers j' and cause the rake-bars to partly turn and withdraw from the straw, &c., and the curved plate i attached to the lower end of the board for turning the rake-bars back to natural position at the lower end of the conveyer, all substantially as and for the purpose described.

5. In an endless conveyer, the combination of the rake-bars having upstanding teeth, journal-pins on their front edges at each end, by which they are hinged on endless belts or chains, and also upstanding tripping-fingers; and a slotted plate overlying the upper surface of the conveyer and covering the rake-bars which travel thereunder while the teeth project upward through and travel in the slots in the plate; with fixed studs attached to the side boards at the discharge end of the conveyer in position to engage said trip-fingers and cause the rake-bars to tilt backward and withdraw from the straw, &c., on the carrier; and a curved plate attached to the lower end of the conveyer adapted to cause said rake-bars to turn into normal position, all substantially as and for the purpose described.

6. In an endless conveyer, the combination of the side and intermediate endless carriers, the sectional rake-bars J having hinge-studs j , j^3 , in their ends pivoted to said side and intermediate carriers substantially as described, and provided with trip-fingers j' , in their

outer ends and also having a series of equidistant upstanding teeth; and a fixed plate overlying said rake-bars having a series of parallel longitudinal slots through which the teeth of the upper series of bars project as they travel thereunder; with a guard-plate I and stationary studs at the discharge end of the conveyer adapted to engage said trip-fingers and cause the rake-bars to partly turn rearwardly and thus withdraw from the straw, &c., as they pass over the upper end of the conveyer, and a plate i attached to the lower end of the conveyer for turning the rake-bars to normal position, all substantially as and for the purpose described.

7. In a conveyer, the combination of the board as b , the sprocket-wheels and shafts at each end thereof, the side and intermediate chains running thereover; the plate I at the discharge end of the conveyer; and the plate i at the receiving end thereof; with the rake-bars J having hinge-studs j , j^3 , on their front edges pivoted to said side and intermediate chains and provided with tripping-fingers j' ; the fixed studs j^5 attached to the side boards adapted to engage fingers j' and cause the rake-bars to tilt backward and withdraw from the straw, &c.; and the plate K covering the board b and overlying the upper set of rake-bars, but provided with longitudinal slots through which the teeth of the upper set of rake-bars project as the bars travel thereunder, all substantially as and for the purpose set forth.

In testimony that I claim the foregoing as my own I affix my signature in presence of two witnesses.

ALVA E. DEWEESE.

In presence of—

WM. H. PUSINGER,
M. C. CLONINGER.