

- 19 -

ABSTRACT

A water supply system including a supply conduit to supply water from a water main, a faucet for water and at least one outlet for water controlled by the faucet.

5 There is a water storage holding tank. A by-pass conduit communicates the outlet for water and the water holding tank. A diverter valve restricts flow through the outlet to water having a temperature within a pre-determined range and diverts to the by-pass conduit water of a
10 temperature outside the pre-determined range. The invention is appropriate to control the temperature of hot or cold water. The diverter valve can be installed within the conduits of the plumbing system or at the outlet.

41691-21

WATER SAVING APPARATUS
FIELD OF THE INVENTION

This invention relates to a water supply system.

5 DESCRIPTION OF THE PRIOR ART

The conservation of water is of increasing concern. That concern is obvious in places such as California, Africa, the Middle East and elsewhere where the population is expanding, the climate is dry and water is scarce. However, even in countries with a plentiful supply of water, domestic water is an expensively treated commodity badly taken for granted by most users. It must be stored in reservoirs and it must be treated to be fit for human consumption. Water is a notorious spreader of disease, particularly in relatively densely populated areas where the water is not treated to render it fit for consumption.

In the use of water in a place where there is a plentiful supply, the waste is high. On an individual level the waste may not be huge but each individual is wasting water to the same extent and the result is that large amounts of treated water are simply fed to the sewer.

One particular source of waste, and one addressed by the present invention, is that every morning, it takes time for the hot water to come through the water pipes to the hot faucet. As a result the first user at each faucet usually turns on the faucet until the water runs hot. In this way, in any one city on any one morning, millions of litres of fresh water can be wasted. The problem is accentuated in hotels, high rise apartments, kibbutzim and office blocks where the source of hot water is usually a considerable distance from the hot faucets.

- 2 -

A similar problem exists where one wishes to drink cold water rather than slightly tepid water that may have been warmed while in the pipe. Again, it is common to run the water until water that is appropriately cold
5 issues from the outlet.

Many people also do not wish to drink water that has sat in a pipe overnight. They prefer to run the water in the belief that the water sitting in the pipe will absorb metal ions from the pipe.

10

SUMMARY OF THE INVENTION

The present invention seeks to solve this waste problem. In a first aspect the present invention is a water supply system including a supply conduit to supply water from a water main, a faucet for water and at least
15 one outlet for water controlled by the faucet. According to the invention the system includes a water storage holding tank with a by-pass conduit joining the water outlet and the water storage holding tank. The system includes a diverter valve to restrict flow through the
20 outlet to water having a temperature within a pre-determined range and to divert to the by-pass conduit water of a temperature outside the pre-determined range. The system can be operated to ensure that in one set of
25 circumstances water that is too cold or, in another set of circumstances, too warm, can be prevented from passing through the outlet and is diverted to the holding tank through the by-pass conduit.

The water storage tank may be pressurized or not and may have one or two float valves to regulate supply.

30

In a preferred aspect, the invention provides a water supply system having a supply conduit to supply water from a water main, conduits to supply hot water from a source of hot water, a faucet for hot water and at

- 3 -

least one outlet for water controlled by the faucet. According to this aspect of the invention there is a water storage holding tank with a by-pass conduit communicating the hot water outlet and the water storage holding tank. A diverter valve restricts flow through the outlet to water of a pre-determined temperature. Water having a temperature below the pre-determined temperature is prevented from passing through the outlet but is diverted to the holding tank through the by-pass conduit.

The valve may be thermostatically or manually controlled. When the system is used until cold water runs an inexpensive thermostat is not sufficiently sensitive for most circumstances and a manually controlled valve is therefore preferred.

DESCRIPTION OF THE DRAWINGS

The invention is illustrated in the drawing in which:

Figure 1 is a schematic diagram of a system according to the present invention;

Figure 2 shows a modification of Figure 1;

Figure 3 is a schematic view of one embodiment of the invention;

Figure 4 illustrates a valve useful in the embodiment of Figure 3;

Figure 5 illustrates a thermostatic valve useful in the invention;

Figure 6 illustrates a butterfly valve useful in the invention;

Figure 7 shows a further modification of Figure 1;

Figures 8 to 13 illustrate variations of flow control to the water storage holding tank.

- 4 -

DESCRIPTION OF THE PREFERRED EMBODIMENTS

The drawings show a water supply system comprising supply conduits. These supply conduits are a main conduit 10 controlled by a main valve 12 and having a side conduit 14 feeding water to a water holding tank 16. Supply to the tank 16 from the conduit 14 is controlled by float valve 18, in turn controlled by float 20. Such valves are common, particularly in plumbing. An abutment 21 is shown to prevent possible damage to float 20. Abutment 21 may not be necessary.

There is a hot water conduit 22 supplying water from a heated source (not shown) typically a tank having an immersion heater or gas heater or, where appropriate, a solar heater. The source of hot water will usually receive water from main conduit 10. Hot water conduit 22 feeds water to a faucet 24. The faucet 24, on being opened, passes water to the outlet 26. There is a by-pass conduit 28 containing a one-way valve 30 that supplies water through inlet 32 to the supply tank 16. Inlet 32 is controlled by float valve 33 with float 34. From the tank 16 there is a cold water conduit 36 that feeds water to a faucet 38, which controls the supply of cold water to the outlet 26 in conventional manner.

Conduit 36 also includes a branch 40 which feeds water to other parts of the domestic system (not shown) for all cold water required, such as toilets, washing machines, cold water faucets, lawn sprinklers and the like. In general fresh water for human consumption will not be routed through the tank 16, and thus will not be routed through conduit 36, but will normally be routed directly to the kitchen from the main conduit 10.

Figure 1 shows a thermostatic diverter valve 42 between the hot faucet and outlet 26. Diverter valve 42 can be set to a pre-determined temperature. Typically it

- 5 -

would be at a desired temperature below the temperature of the domestic hot water, for example at about 32°C.

Tank 16 also has an outlet 44 including a one-way valve 46 communicating with the main conduit 10. At the point of communication there is a siphon mechanism 48, which with the flow of water in the main conduit 10, can siphon off any water above a pre-determined level in tank 16, for example to replenish the hot water tank. The water is drawn from the tank 16 through pipe 44 into the main conduit 10.

The system of Figure 1 functions as follows. When the faucet 24 is opened, relatively cold water passes from the conduit 22 through the faucet 24. Normally it would be passed through the outlet 26 and the user, not being satisfied with that temperature, would simply allow it to pass to waste.

However, using the system of the invention the valve 42 remains closed so that the relatively cold water passing down conduit 22 is diverted through one-way valve 30 into by-pass conduit 28, through inlet 32 into tank 16. The valve 30 is not essential. This by-passing of the water continues until the water passing valve 24 is warm enough to open valve 42. At that point the water passes through valve 42 through the outlet 26.

During normal use, for example in the day, when the water in the pipe 22 is reasonably warm most of the time, valve 42 will remain open. In those circumstances, when the water from by-pass conduit 28, stored in tank 16, has been used, supply to the tank 16 will be through the normal main supply 10, controlled by float valve 18 through side conduit 14. In conventional manner the main conduit 10 also supplies water to the hot water tank. If desired, supply from the mains need not go through the

- 6 -

tank 16 but may go directly to outlet 36 but still be controlled by a one-way valve - see Figure 12.

Tank 16 need not receive water from main conduit 10. It may be preferable to have the domestic water supply for cold water (except, perhaps drinking water) from one source to reduce plumbing requirements but in retrofitting the system of the invention to existing plumbing, location may make the joining of conduit 10 to tank 16 difficult or undesirable.

The use of float valves 18 and 33 means that the tank 16 is not subjected to the pressure of the water in the main conduit 10. This means that tank 16 need not be pressure resistant, reducing the expense of the system. Two floats, 20 and 34 are shown but one float can be used to control both valves 18 and 33, should it be desirable.

Tank 16 can also be pressurized as desired. Pressurized tanks, which may include an internal bladder, are known in plumbing.

Siphon mechanism 48 acts as a siphon which ensures that the tank 16 usually contains only a small amount of water. Stored water does not stand in the tank 16 but is emptied relatively quickly back into the main conduit 10 which supplies water to the heating tank.

In the embodiment of Figure 1 diverter valve 42 is thermostatic. It is pre-set to a particular temperature and opens when the water in conduit 22 reaches that temperature. A manually operated valve is equally acceptable and may have the advantage of cheapness. In those circumstances either the user can make an educated guess as to when the water will be warm or, preferably, a heat conductor 50, shown in Figure 2, can be provided so that the user can know by touch that the water reaching

- 7 -

valve 42 is of the required temperature. When that observation is made, valve 42 is manually opened and the water then passes to outlet 26. A visual observation can be made, for example, by noting a heat sensitive colour change or by use of a thermometer.

Figures 3 and 4 illustrate a variation of the invention using a valve common in plumbing where it is required to divert the water from the faucet to, for example, a washer spray, typically mounted on a flexible tube. In the embodiment of Figure 3 the diverter valve 42 is positioned in the by-pass conduit 28 and is arranged to close when the temperature reaches a certain value as distinct from open, as illustrated in Figures 1 and 2.

Figure 3 shows a mixer faucet 51, that is a faucet that is provided with passageways in a valve member to mix the water from two sources, hot and cold, so that a mixed stream passes through the outlet 26. Where a spray is also fitted, then there is typically a third conduit to the valve and this third conduit may be used in the present invention. The third conduit is shown in Figure 3 as conduit 52 and the valve is shown as 54. Details of a typical valve are shown in Figure 4.

Valve 54 of Figure 4, is usually located within the faucet body and is designed so that when valve 42 is closed the water passes through openings 56 in the valve body, controlled by a flap valve 58, and downwardly. There is a tulip valve 60 within the body having a head 62, a hollow stem 64 and a flange 66. The flange 66 sits in an opening 68 in the bottom portion of the valve 54. As is clear from Figure 4 the valve 60 can fall under its own weight to the position shown in solid lines in Figure 4. The lower end of stem 64 is received in a tube 70 in communication with conduit 52. With valve 42 closed

- 8 -

water passes through the openings 56, through the body of the valve 54, out of the opening 68 at the bottom and then to the outlet 26, controlled by faucet 51.

However when diverter valve 42 is opened, the
5 pressure in the upper compartment of the valve 54 tends to be reduced. Water pressure therefore drives the head 62 upwardly, seating the lower flange 66 in opening 68. Because of the reduced pressure, the valve 60 is held up in the body of the valve 54 and water passes down the
10 stem 64, through the tube 70 to the conduit 52.

The diverter valve 42 in Figure 3 is open until the temperature reaches a certain point. This means that the pressure within the valve of Figure 4 is such that the water passes preferentially to the conduits 52 then 28,
15 and through the valve 42. However, when the valve 42 closes, that is when the water reaches a required temperature, there is a pressure build-up in the conduit 52. In these circumstances, the valve 62 moves downwardly, to the solid line position of Figure 4, and
20 the water flow is through the openings 56 and out to the outlet 26. Again, valve 42 in Figure 3 may be thermostatically or manually controlled.

Figure 5 illustrates a further variation of the invention where the diverter valve 42 is located on the
25 end of outlet 26. The valve is threaded into outlet 26 and includes a bimetallic strip 72. The bimetallic strip is attached to a valve member 74 seated on a flange 76 to close off the outlet 26 until an appropriate temperature is reached. As well known, a bimetallic strip 72
30 comprises two materials of different co-efficients of expansion. With the temperature change the two metals expand at a different rate causing the bimetallic strip to curl or straighten. This phenomenon is used in the present invention to open or close the valve 74.

- 9 -

Figure 6 illustrates a simple manual valve that can be used at the outlet, as in Figure 5, or as the manually controlled diverter valve 42 within the system, as shown in Figures 1, 2 and 3. The valve comprises shaft 78 to which is attached a butterfly valve 80. The shaft 78 has a head 82 to allow rotation of the shaft 78 and thus of the butterfly valve 80 to close or open the valve 42. This valve is well known in the prior art.

Although Figure 6 illustrates a mechanically operated valve, that is a conventional butterfly valve, it will be appreciated that any simple mechanical valve that can be used to close off a passageway is appropriate. For example, the push/pull valve used to operate a shower in a bathtub, which acts to divert the water from the faucet to the shower head, can be used.

It should also be noted that diverter valve 42 can be provided in a threaded cartridge, that is to say in a length of tubing having threads at both ends. This greatly facilitates installation of a valve 42. The existing piping can be cut and threaded with appropriate threads to receive the threads on the cartridge. Soldering can also be used to attach a cartridge containing the valve 42.

The system of Figure 1 shows a hot water system. However, the same principle applies when it is desired to avoid feeding tepid water, when cold water is desired. In those circumstances, the valve 42 can be controlled to open when the water temperature falls to a certain level. That is water above that temperature is by-passed to the tank 16. With this cold water use, temperature variations are not great and a thermostat may not be sufficiently sensitive. A manual control as shown, for example in Figure 6, is therefore preferred.

- 10 -

Figure 7 illustrates a variation of the invention where there are valves 42 controlling the hot and the cold water. The arrangement is as shown in Figure 1. A short additional conduit 84 is included having a one-way valve 86. In this system valves 42 function whenever one of the faucets 24 or 38 is opened. Conduit 84 is a cold water by-pass joining the conduit 28. One way valve 86 ensures that water does not feed back through conduit 28 when valve 42 is open.

10 Figures 8 to 12 illustrate ways in which water passed to the water storage holding tank can be returned into the water supply as soon as possible and not spend time in that tank. The drawings show embodiments that are applicable either to pressurized water holding tanks, some of which include an internal bladder, although not necessarily, and non-pressurized tanks.

Referring to Figure 8, there is shown a pressurized water holding tank 116 that receives water from the diverter valve 42 (not shown) through pipe 128 and branch pipe 150. The branch pipe 150 is an inlet/outlet pipe in that water passes to the tank 116 from pipe 150 and is returned to the system through the same pipe 150. There is a one-way valve 152 in pipe 150. Water supply is through the mains pipe 110 and is controlled by a valve 154 which operates on the principal of a float valve but is operated by a lever 156 having a magnet 158 at one end. The valve 152 is opened when there is water pressure in the tank 116. A magnetic member then extends from the one-way valve 152 and acts to repel the magnet 158 on the lever 156. This closes the valve 154 in the mains pipe 110 thus preventing supply of water from the mains. Water may then leave the pressurized tank 116 to join the pipe 110. When the pressure is relieved the magnetic member retracts and the lever 156, with the magnet 158 on it, falls to open the valve 154 and allow

- 11 -

supply. In this way, any pressure generated in the tank 116 opens the valve and drains the tank 116. The treated water is returned to the system and is not simply wasted to the sewer.

5 Figure 9 shows the same arrangement of a pressurized tank 116 and, inlet/outlet pipe 150 and a one-way valve 160. The same reference numerals are used, as appropriate, as in Figure 8. The valve 160 in Figure 9 is not magnetically operated.

10 Figure 9 shows a by-pass box 162. When the by-pass box 162 is filled as a result of water pressure in the water holding tank 116, a float valve 164, having a float 166, acts to close the main supply 110. Water then drains from the water holding tank 116 and from the water
15 by-pass box 162. The tank 162 is emptied and the float 166 moves downwardly. By so doing, it opens the main supply 110 and the mains system continues to operate. Again water from the water holding tank 116 is immediately returned to the system and is not simply
20 wasted to the sewer.

 Figure 10 resembles Figure 9 and, again, the same reference numerals are used as appropriate. However the water by-pass box in Figure 10 is different from that in Figure 9. When water is present in the by-pass box 162,
25 that water acts to raise a float valve 168 which closes off the main supply valve 164. As a result, the tank 116 drains. The float valve 168 then drops and supply from the mains 110 then continues. The embodiment of Figure 10 differs from that of Figure 9 in that water from the
30 main supply 110 passes into the by-pass box 162 in Figure 10 but does not do so in the embodiment of Figure 9.

 Figures 11 and 12 show non-pressurized tanks 216. Flow in them is controlled by float valves. In Figure 11

- 12 -

water from the diverter valve 42 enters the tank 216 through valve 170, controlled by float 172. When the water tank 216 reaches a predetermined level the valve 170 closes. There is a siphon 174 with a one-way valve 176 that allows water to be withdrawn from the water holding tank 216 by flow in the mains pipe 110. Such a valve 176 is able to withdraw about six volumes of liquid from the tank 216 for every one volume of flow along pipe 110. If such a flow rate is inadequate, then additional valves 176 and siphon mechanisms 174 can be used to draw out water more rapidly. Figure 11 also shows the use of a branch pipe 178 through which water may be fed to, for example, a solar heater or any other type of heater. In Figure 11, the conduit 110 is shown as passing through tank 216, while in Figure 13, the conduit 110 is external to tank 216.

In Figure 12 the system illustrated resembles that in Figure 1 including the use of two floats. The same reference numerals are used as in Figure 1, as appropriate. In Figure 12 there is a drain pipe 180 having a one-way valve 182. When the tank 216 starts to fill up float 184 closes supply from the mains 10 and the tank drains through pipe 180, controlled by one-way valve 182. When the float 184 lowers the mains supply is opened and supply continues. At the same time the tank 216 is emptied.

A number of variations in the illustrated apparatus are possible. Valves 42 are shown to be manually controlled or thermostatically controlled. However they may be controlled hydraulically or electronically and placed in an appropriate place in the system. The tank 16 may be part of the main supply tank for hot water.

Furthermore, it should be noted that embodiments of the present invention comprising non-pressurized tanks

- 13 -

may further optionally comprise an overflow (not shown) attached to the tank at a predetermined maximum upper level, said overflow being in open communication to the and serving to divert water out of the tank in cases when
5 the level of water in the tank reaches said maximum upper level. The said maximum upper level is typically set at some distance above the level of the inlet valves to the tank, for example 33 and 18 in Figure 1. Tank overflows, as described above for example, are common in the art and
10 are particularly useful when said inlet valves, for example 33 and 18, malfunction and remain fixed in the open position: the tank continues to fill up, and the overflow serves to safely divert the excess water out of the tank.

15 The present invention thus avoids a substantial waste. That waste may be relatively small in any one house but is of major significance when viewed collectively and is also of major significance in any one hotel, apartment block or office block where there is a
20 single supply of hot water and the distance between the hot water faucet and that supply can be quite considerable.

The system is simple to install. It can easily be built into new living or commercial buildings, at
25 relatively minor cost, but can also be retrofitted to existing systems.

Although the present invention has been described in relation to particular embodiments thereof, it is not limited thereto, and many other variations and
30 modifications thereof are possible, as will be apparent to one skilled in the art. It is therefore intended that the present invention is only limited by the scope of the appended claims.

- 14 -

The embodiments of the invention in which an exclusive property or privilege is claimed are defined as follows:

1. In a water supply system including a main conduit to supply water from a water main, a faucet for water, a conduit to supply water from said main conduit to said faucet, and at least one outlet for water controlled by said faucet, the improvement comprising:
 - a water storage holding tank;
 - 10 a by-pass conduit communicating the outlet for water and the water storage holding tank;
 - a diverter valve to restrict flow through the outlet to water having a temperature within a pre-determined range and to divert to the by-pass conduit water of a temperature outside said pre-determined range; and
 - 15 means to withdraw water from the water storage holding tank and to feed water withdrawn from said tank back to the main conduit.
2. A water supply system as claimed in claim 1 in which the faucet is a cold water faucet and the diverter valve restricts flow through the outlet to water below a pre-determined temperature.
3. A water supply system as claimed in claim 2 in which the diverter valve is manually controlled.
- 25 4. In a water holding system including a main conduit to supply water from a water main, a faucet for hot water, a conduit to supply hot water to said faucet from a source of hot water supplied with water by said main conduit, and at least one hot water outlet controlled by said faucet, the improvement comprising:
 - 30 a water storage holding tank;
 - a by-pass conduit communicating the hot water outlet and the water storage holding tank;

- 15 -

a diverter valve to restrict flow through the outlet so water of a pre-determined temperature, whereby water below said pre-determined temperature can be prevented from passing through the outlet but is diverted to said holding tank through said by-pass conduit; and

5 means to withdraw water from the water storage holding tank and to feed water withdrawn from said tank back to the main conduit.

5. A water supply system as claimed in claim 4 in which the diverter valve is between the hot faucet and its outlet.

6. A water supply system as claimed in claim 5 in which the diverter valve is thermostatically controlled.

7. A water supply system as claimed in claim 4 in which the diverter valve is manually controlled.

8. A water supply system as claimed in claim 7 including means to allow a user to determine when the pre-determined temperature has been reached.

9. A water supply system as claimed in claim 4 in which the diverter valve is located in the by-pass conduit.

10. A water supply system as claimed in claim 9 in which the apparatus includes a diverter conduit between the hot water outlet and the by-pass conduit;

a second diverter valve associated with the diverter conduit and able to divert water from the hot water outlet to the by-pass conduit when the diverter valve in the by-pass conduit is open;

said diverter valve in the by-pass conduit being open when the temperature is outside a pre-determined range and closed when the temperature is within said pre-determined range.

- 16 -

11. A water supply system as claimed in claim 4 in which the diverter valve is at the outlet.

12. A water supply system as claimed in claim 4 including a conduit to supply water to the water storage
5 holding tank from the main conduit.

13. A water supply system as claimed in claim 12 including a float valve to control water supply to the water storage holding tank from the main conduit.

14. A water supply system as claimed in claim 4 in which
10 the means to withdraw water from the water storage tank and to feed water withdrawn from said tank back to the main conduit comprises;

an outlet from the water holding tank to the main conduit;

15 a one way valve in the outlet restricting flow towards the main conduit;

a siphon mechanism in the main conduit whereby passage of water through the main conduit draws water from the water storage holding tank, through the outlet,
20 into the main conduit.

15. A water holding system comprising a main conduit to supply water from a water main;

a source of hot water supplied with water by said main conduit;

25 a faucet for hot water;

a first conduit to supply hot water to said faucet from said source of hot water;

at least one hot water outlet controlled by said faucet;

30 a water storage holding tank separate from said source of hot water;

a by-pass conduit communicating the hot water outlet and the water storage holding tank;

- 17 -

a diverter valve to restrict flow through the outlet to water of a pre-determined temperature, whereby water below said pre-determined temperature can be prevented from passing through the outlet but is diverted to said holding tank through said by-pass conduit;

a second conduit from the water holding tank to the main conduit;

a one-way valve in the second conduit restricting flow towards the main conduit;

a siphon mechanism in the main conduit positioned so that passage of water through the main conduit draws water from the water storage holding tank through the second outlet into the main conduit.

16. A water supply system as claimed in claim 1 in which the faucet is a cold water faucet and the diverter valve restricts flow through the outlet to water above a predetermined temperature.

17. A water supply system as claimed in claim 16 in which the diverter valve is manually controlled.

18. A water supply system as claimed in any one of claims 1 to 17 including a float valve to control water supply to the water storage holding tank from said by-pass conduit.

19. A water supply system as claimed in any one of claims 1 to 18, wherein said water holding tank is a pressurized water holding tank.

20. A water supply system as claimed in any one of claims 1 to 18, wherein said water holding tank is a non-pressurized water holding tank.

21. A water supply system as claimed in claim 20, wherein said non-pressurized water holding tank further

- 18 -

comprises an overflow pipe having an inlet in communication thereto.

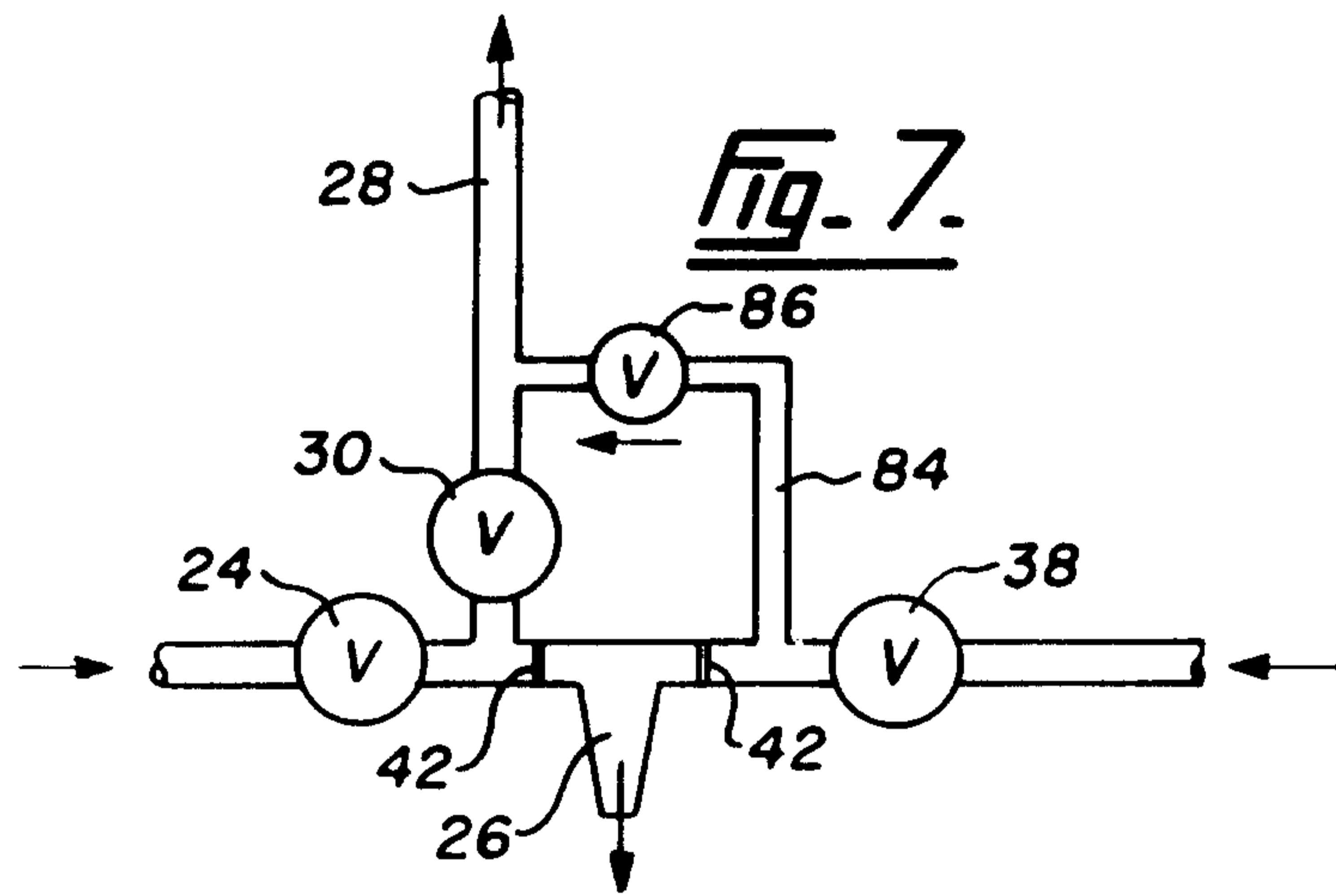
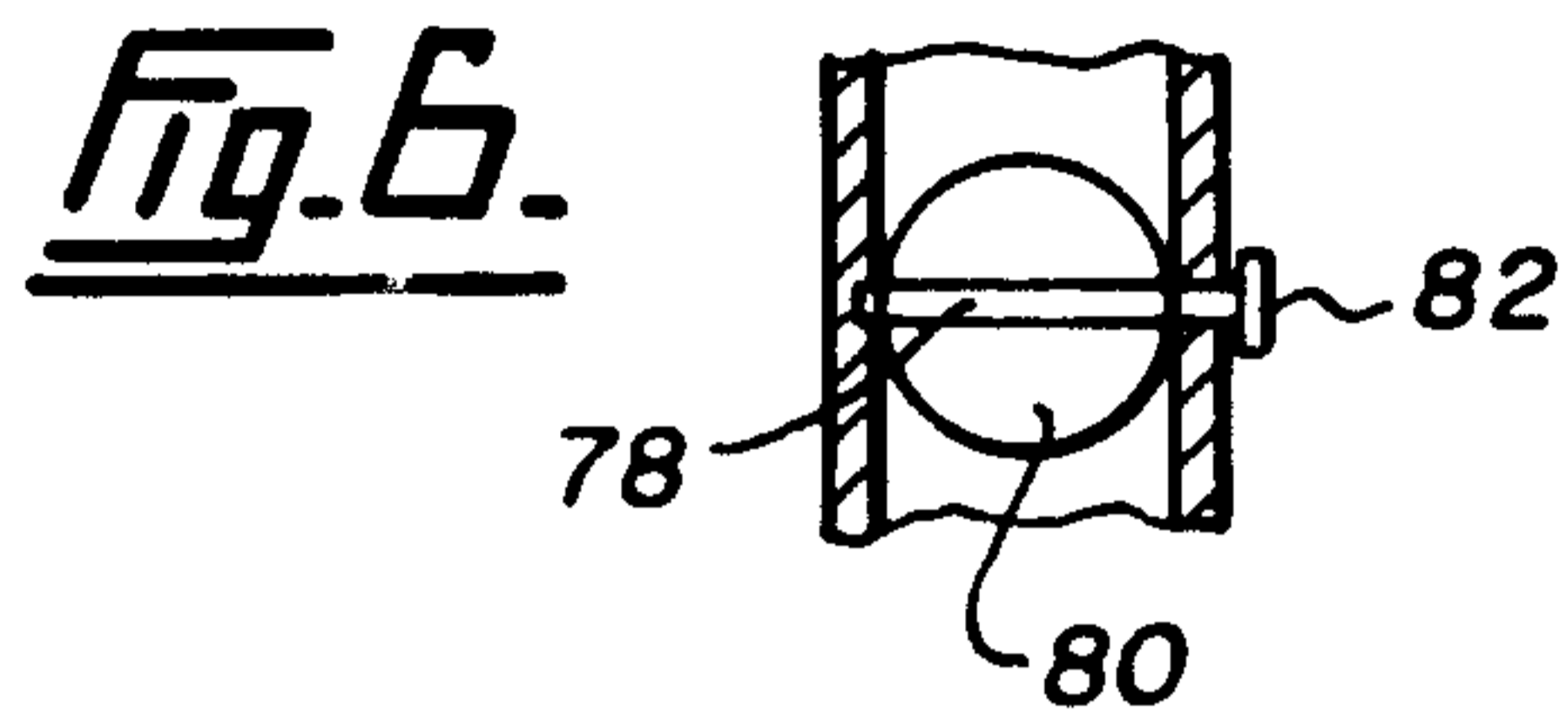

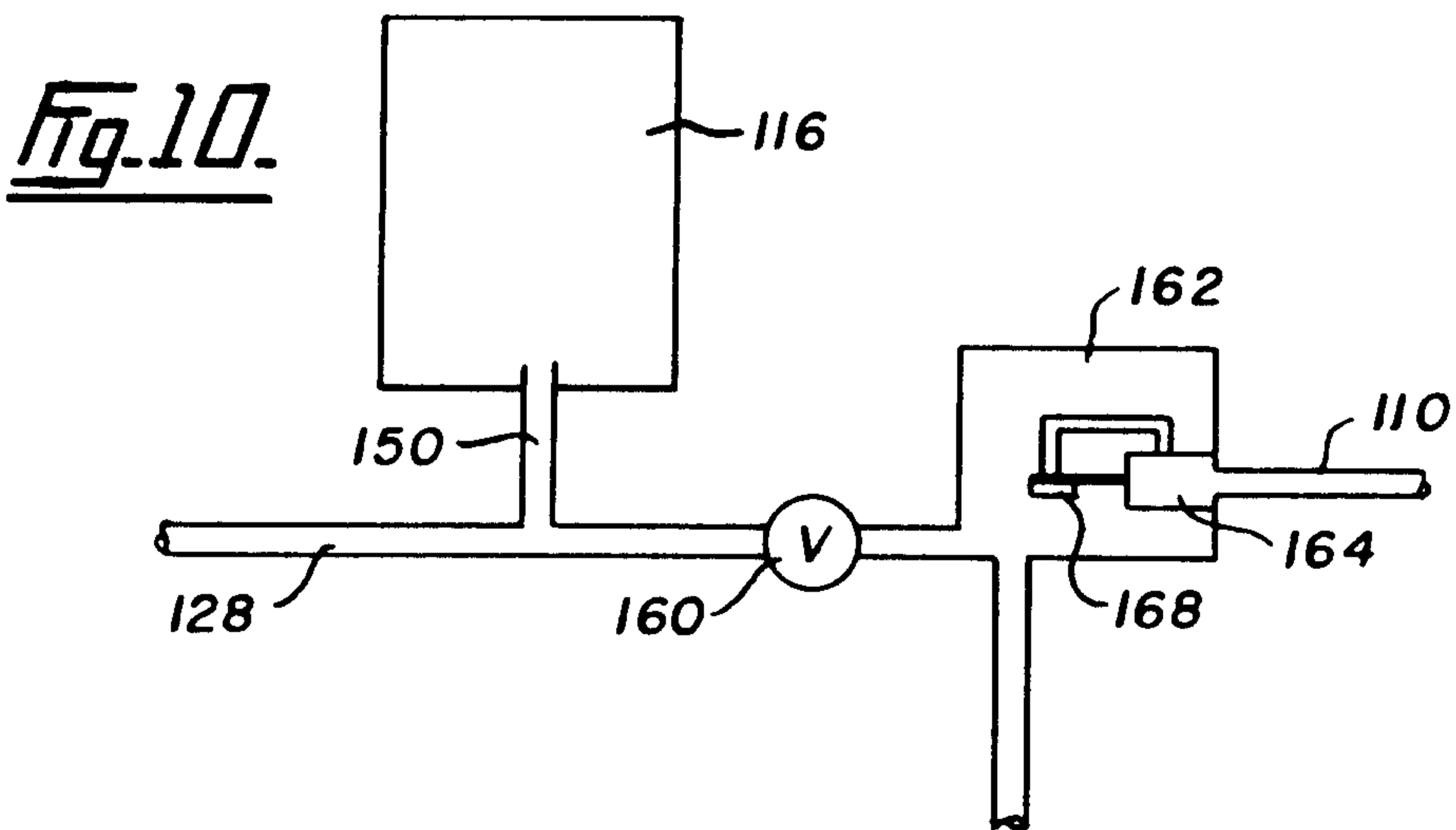
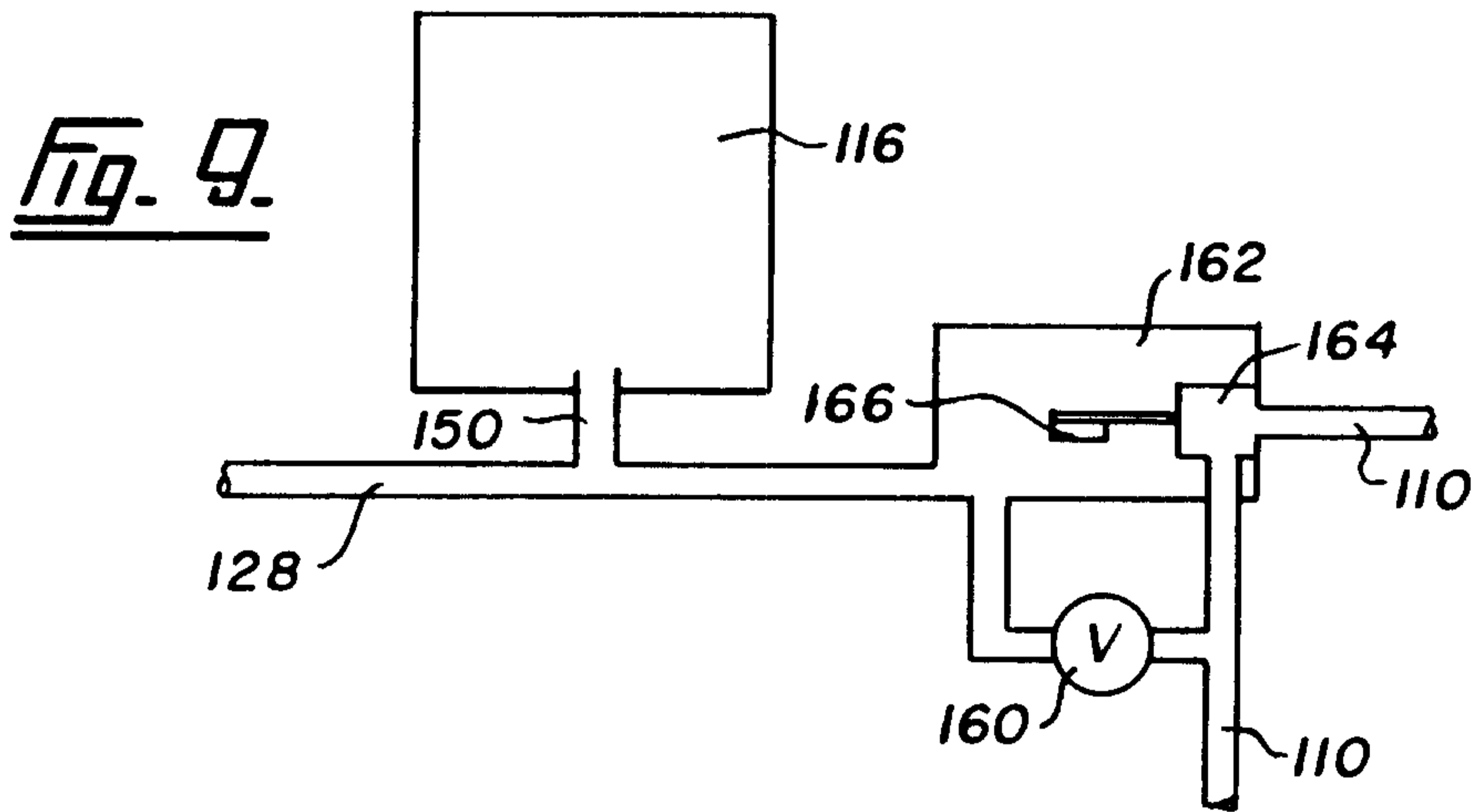
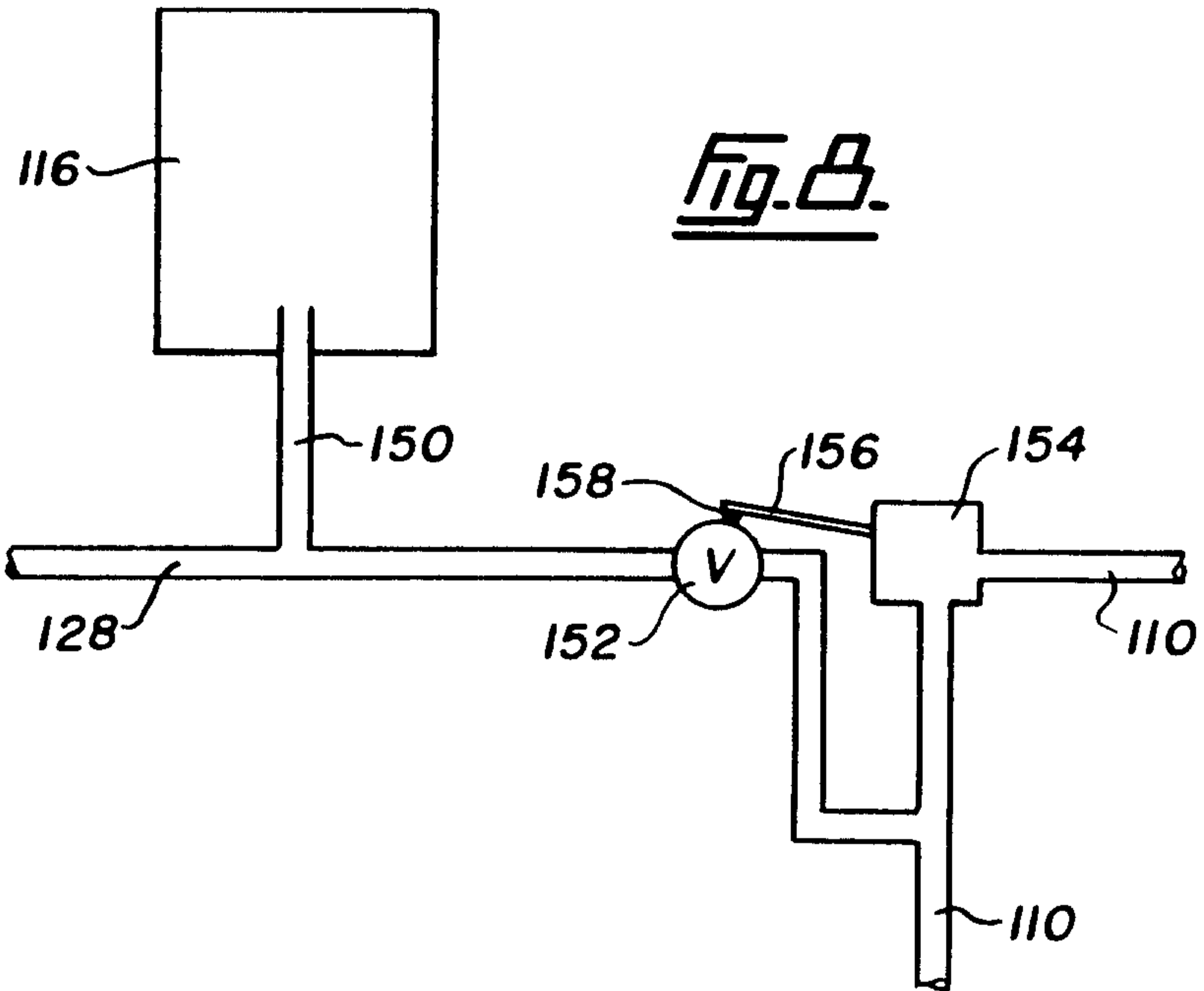

Fig. 11.

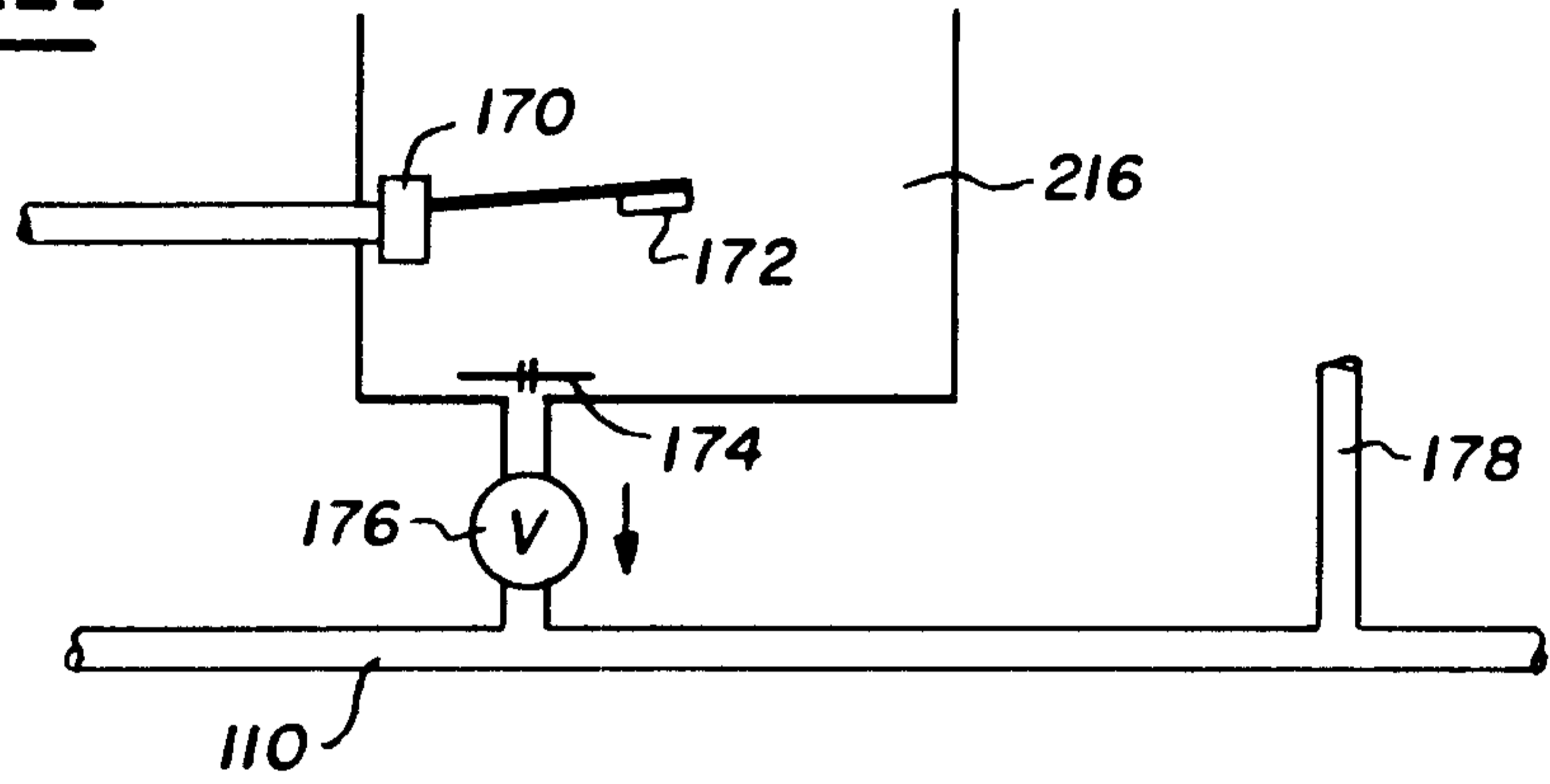

Fig. 12.

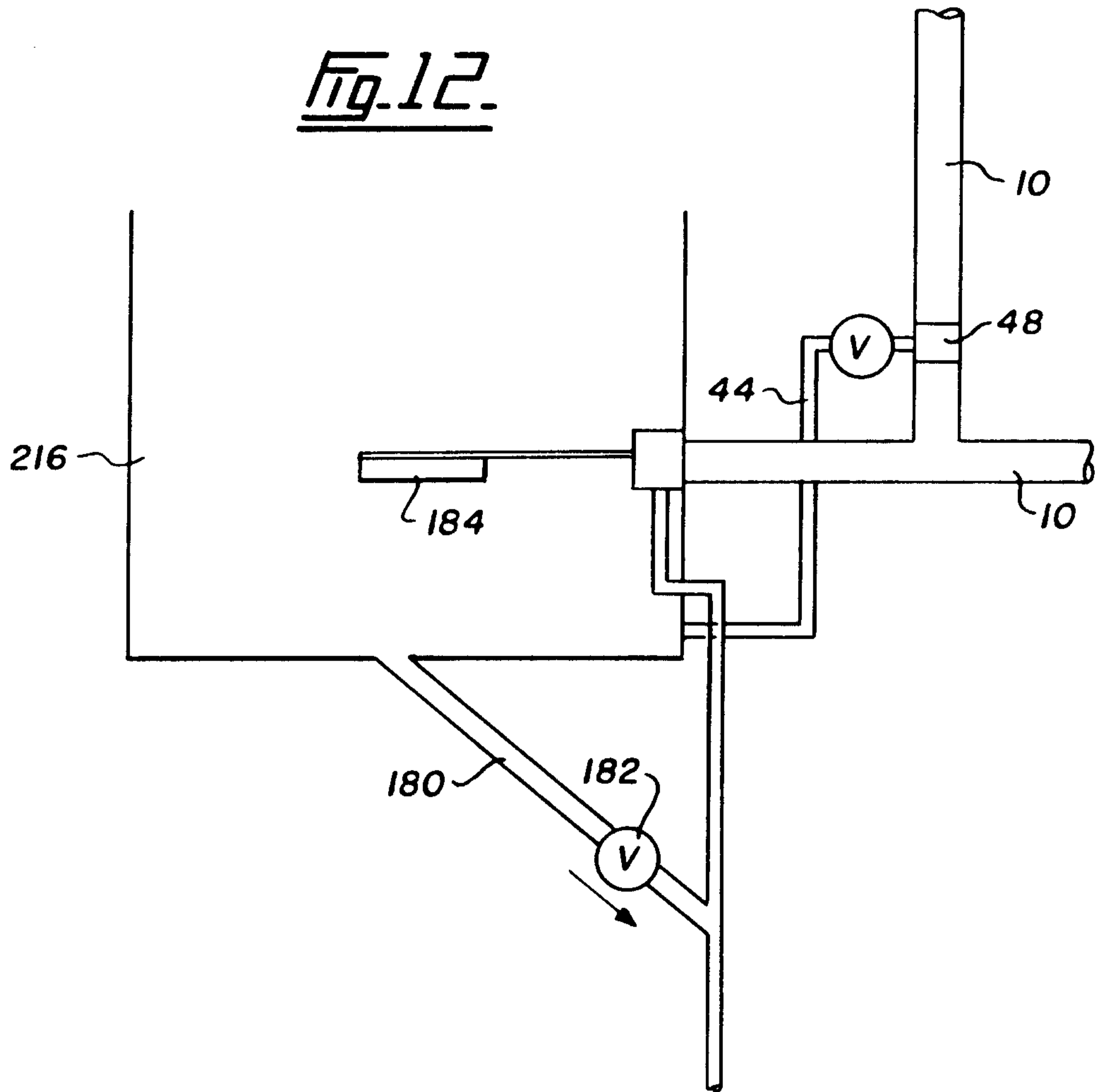

Fig. 13.

