



(11) **EP 2 573 387 B1**

(12) **EUROPEAN PATENT SPECIFICATION**

(45) Date of publication and mention of the grant of the patent:
25.05.2016 Bulletin 2016/21

(51) Int Cl.:
F03D 80/80 ^(2016.01) **F03D 13/10** ^(2016.01)
F03D 1/00 ^(2006.01)

(21) Application number: **11182332.4**

(22) Date of filing: **22.09.2011**

(54) **Nacelle for a wind turbine**

Gondel für eine Windturbine

Nacelle pour éolienne

(84) Designated Contracting States:
AL AT BE BG CH CY CZ DE DK EE ES FI FR GB GR HR HU IE IS IT LI LT LU LV MC MK MT NL NO PL PT RO RS SE SI SK SM TR

(43) Date of publication of application:
27.03.2013 Bulletin 2013/13

(73) Proprietor: **Siemens Aktiengesellschaft**
80333 München (DE)

(72) Inventor: **Munk-Hansen, Thorkil**
7323 Give (DK)

(56) References cited:
EP-A2- 2 063 119 US-A1- 2005 230 979
US-A1- 2011 008 166 US-A1- 2011 163 543

EP 2 573 387 B1

Note: Within nine months of the publication of the mention of the grant of the European patent in the European Patent Bulletin, any person may give notice to the European Patent Office of opposition to that patent, in accordance with the Implementing Regulations. Notice of opposition shall not be deemed to have been filed until the opposition fee has been paid. (Art. 99(1) European Patent Convention).

Description

[0001] The invention relates to a nacelle for a wind turbine.

[0002] A wind turbine transforms wind energy into electrical energy.

[0003] The wind energy causes a rotation of the rotor of the wind turbine. The rotor of the wind turbine comprises a hub and at least one rotor blade mounted to the hub. The hub is connected rotatable to the nacelle. The nacelle comprises an electrical generator. The rotation of the hub is transferred to the generator and the generator transfers the rotational energy into electrical energy.

[0004] The loads of the wind acting on the rotor are transferred over one or more bearings to a load-carrying structure. The load-carrying structure is a part of the nacelle and connects the nacelle to the tower of the wind turbine. The loads and the weight of the components of the rotor and the nacelle are transferred to the tower.

[0005] The load-carrying structure is connected to a tower in a way that the nacelle can be rotated on the tower. A yaw system rotates the nacelle on the tower in a way that the rotor of the wind turbine faces the direction of the wind.

[0006] A wind turbine comprises different systems and components that are necessary for the operation of the wind turbine like a control system or a cooling system. The systems and components are connected by electrical connections, hydraulic connections or fluid tight pipes for example for the cooling system. Most of the systems and components are located in the nacelle of the wind turbine.

[0007] Some of the systems and components, like the electrical system, are mounted on a support structure. The support structure is connected to the load-carrying structure of the nacelle.

[0008] The nacelle of a wind turbine proves to be a critical part in respect of the operational reliability and lifetime of the wind turbine. The nacelles of wind turbines are produced in an in-line-production in the factory to achieve a cost effective production and a high quality. The nacelle is then shipped to the erection site of the wind turbine.

[0009] In recent year the effective electrical power generated with a single wind turbine continuously increased. The components of the wind turbine, like the blades, the hub, the nacelle and segments of the tower also increased in size and weight.

[0010] EP 2063119 concerns a module of a nacelle of a wind turbine, which is separately designed, manageable and comprises a housing part. The module is connectable to at least one further module of the nacelle, which is also separately designed, manageable and has a housing part.

[0011] The size and weight of the single parts of the wind turbine are limited due to the regulations for the transport of the parts on public roads. This is also the case for the nacelle of the wind turbine.

[0012] The transport on public roads requires a certain maximum size of the components and specialized transport vehicles. In addition a special heavy-load transport requires a long period for planning and to get the required permission from the authorities.

[0013] It is the aim of the invention to provide a nacelle for a wind turbine that is easier to be transported.

[0014] The aim is reached by the features of the independent claim. Preferred embodiments of the invention are described in the dependent claims.

[0015] A Nacelle for a wind turbine comprises a generator, a load-carrying structure, a support structure, an electrical system, a yaw system, a control system and a housing. The generator comprises a rotating part and a stationary part and the stationary part is connectable to the load-carrying structure.

[0016] The load-carrying structure comprises the yaw system and the control system. The support structure comprises the electrical system and the support structure is connectable to the load-carrying structure. The housing is segmented and is connectable to at least the load-carrying structure.

[0017] The generator, the load-carrying structure and the support structure are separate modules and the separate modules and the segmented housing are connectable at an erection site of the wind turbine to build the nacelle.

[0018] The nacelle of a wind turbine comprises a load-carrying structure that is capable to transfer the loads from the rotor of the wind turbine to the tower. When the turbine is erected, the stator side of the generator is mounted to a first side of the load-carrying structure. The second side of the load-carrying structure is rotatable mounted to the tower of the wind turbine.

[0019] The nacelle of a wind turbine comprises a support structure that carries systems and components present in the nacelle. When the turbine is erected, the support structure is connected to the load-carrying structure of the nacelle.

[0020] Systems and components in the nacelle of the wind turbine can either be connected directly to the load-carrying structure or indirectly for example via a support structure.

[0021] The electrical system of the wind turbine is at least partially located in the nacelle of the wind turbine. These parts are for example the converter, the transformer or cabinets with electrical and electronic equipment.

[0022] The nacelle of the wind turbine comprises a control system. The control system controls for example the electrical system, the hydraulic system, the pitch of the rotor blades, the yaw system of the nacelle, the brake of the rotor and the converter of the wind turbine.

[0023] The nacelle comprises a housing that is constructed to protect the systems and components in the nacelle from the influence of the surrounding environment. The housing of a larger nacelle is segmented for an easier transport.

[0024] The nacelle is prepared as separate modules.

Those modules are transported to the erection site of the wind turbine and are connected to build the nacelle of the wind turbine.

[0025] The modules are either connected before the nacelle is lifted up on the tower of the wind turbine or the modules of the nacelle are lifted up separately and are then connected to each other.

[0026] The modules can also be connected at an erection site of the wind turbine where the nacelle is erected. This can be near a harbor for example. The nacelle is then transported to the tower and lifted up onto the tower.

[0027] The modules are transported, thus they need to fulfill the requirements and limitations of transportation. Thus the complete nacelle can be larger than the maximum size limited by the transportation regulations. Thus more space is available in the nacelle.

[0028] Thus the systems and components can be arranged in a more useful way to optimize cooling of the components. Thus the components can also be arranged in a way to optimize service and maintenance work performed in the nacelle.

[0029] Thus the modules of the nacelle are lighter in weight than the whole nacelle. Thus the modules are easier to transport and easier to handle. Thus the transportation vehicle can be a normal transportation vehicle and does not need to be a special heavy-load vehicle. Thus the transport of the modules is cheaper.

[0030] The transport of the modules can at least for some of the modules be performed as a normal transport on public roads. Thus it is not necessary to arrange a special heavy-load or wide load transport for those modules.

[0031] A system present in the nacelle of the wind turbine comprises connections to different components. The cooling system for example comprises a pump and a control unit and is connected to a heat exchanger and at least one heat source.

[0032] Connections need to be established from the module that comprises a part of the system to the other modules that comprise other components of that system. The module to which the system is mounted is chosen in a way the number of connections that are needed between the modules is minimized.

[0033] The load-carrying structure for example comprises the yaw system including the control of the yaw motors. The yaw motors are connected to the load-carrying structure. Thus no connections from one module to another module are needed to connect the yaw motors to the control of the yaw motors.

[0034] The load-carrying structure comprises the control system of the wind turbine. The control system needs to be connected to a lot of different components of the wind turbine. The load carrying structure is the central module of the modules of the nacelle.

[0035] Thus by placing the control system in the load-carrying structure the number of connections of the control system to the other modules is minimized.

[0036] Thus the number of connections that have to

be made when the modules are connected is minimized. Thus installation time is minimized. Thus also the possibility of a faulty connection is minimized.

[0037] The connections that have to be established when the modules are connected are prepared in a way that they are easily connectable. The connections can be prepared by providing a connecting piece in the connection.

[0038] Thus the connections can be established fast when the modules are connected. Thus no further installation material is needed at the erection site of the wind turbine to establish the connection.

[0039] In a preferred embodiment the load-carrying structure comprises at least a part of a cooling system.

[0040] The nacelle comprises a cooling system. The cooling system is constructed to transfer the heat present in the components to a heat exchanger, where the heat is transferred to another cooling medium like the ambient air.

[0041] A part of the cooling system is for example the pump of the cooling system, a valve of the cooling system or a connection of the cooling system.

[0042] The part of the cooling system can also be the control of the cooling system. When the control of the cooling system is located in the load-carrying structure the number of connections that have to be established when the modules are connected is minimized.

[0043] Thus the connections to connect the parts of the cooling system are established very quickly, and the risk of a faulty connection is minimized. Thus the installation time is minimized.

[0044] In a preferred embodiment a radiator is provided connectable to the housing.

[0045] A radiator is used as a heat exchanger and is a part of the cooling system. The heat from for example the generator is transported by a first cooling fluid. In the radiator the heat from a first cooling fluid is transferred to a second cooling fluid. The second cooling fluid is for example the ambient air.

[0046] The radiator is provided connectable to the housing. Thus the radiator can be transported separate from the other modules to the erection site of the wind turbine.

[0047] Thus the parts of the housing that need to be transported are smaller and the transport of the housing of the nacelle is easier.

[0048] According to the invention the generator comprises a hydraulic unit mounted to the stationary part of the generator.

[0049] A nacelle comprises a hydraulic system. The hydraulic system is used for example to operate the brake and lock of the rotor of the wind turbine or to control the pitch of a rotor blade.

[0050] A hydraulic unit is for example a pump of the hydraulic system or a pressure-storage. The hydraulic unit needs to be connected to the brake and the hub of the nacelle. The hydraulic unit is mounted to the stationary part of the generator.

[0051] Thus the number of connections needed to connect the hydraulic unit with the other hydraulic components is minimized. Thus the connections can be established fast.

[0052] In a preferred embodiment the electrical system comprises a transformer and a converter, to adapt the power of the generator to apply to a power grid condition of a power grid.

[0053] The nacelle comprises an electrical system that transfers the electrical energy from the generator to a connection to the power grid. This electrical system comprises a transformer and a converter, which can be located in the nacelle.

[0054] The converter and the transformer are both located in the nacelle of the wind turbine. Thus the connection between the converter and the transformer is short. Thus the connection can already be installed when the module is prepared. Thus no separate connection has to be established at the construction site.

[0055] In a preferred embodiment a platform to be used with a helicopter is provided that is connectable to the housing.

[0056] A platform to be used with a helicopter is a helipad, a heli-drop zone or a heli-hoist platform for example.

[0057] Preferably it is a heli-hoist platform. A heli-hoist platform is a platform constructed to lower parts or personnel from a helicopter to the platform or to hoist them up from the platform to the helicopter.

[0058] The platform can be segmented. The platform is prepared separate from the housing of the nacelle and is connected to the housing at the erection site.

[0059] Thus the parts of the housing that need to be transported are smaller and the transport of the housing of the nacelle is easier.

[0060] In a preferred embodiment the electrical system is electrically connectable to the generator and the power grid.

[0061] The electrical system of the wind turbine is prepared in a way that it can be connected to the generator and the power grid. The connection is prepared by providing the cables that are needed for the connection in the modules. The cables can be equipped with a connector or they can be provided long enough to be guided into the adjacent module to be connected directly to the concerning component.

[0062] Thus the connection can be established at the erection site of the wind turbine. Thus no further installation equipment is needed at the erection site.

[0063] In a preferred embodiment a pipe or hose of the cooling system is connectable to the radiator, the generator and/or the electrical system.

[0064] The cooling system transfers the excess heat from the components of the wind turbine via a first cooling fluid to the heat exchanger. A typical source of excess heat can be the generator, the main bearing, the converter, the transformer or the hydraulic system for example.

[0065] The cooling system is connected to all heat

sources that need to be cooled and to the radiator acting as a heat exchanger.

[0066] A connection has to be established between the cooling system present in one of the modules, the radiator and the units that need to be cooled.

[0067] A hose or pipe is provided as a connection between the cooling system and the radiator or the cooling system and the units that need to be cooled. This hose or pipe is connectable to the mentioned units in the different modules. So the connection can be established after the modules are connected.

[0068] Thus the connection is already prepared. Thus the connection can be established in a quick and easy manner.

[0069] In a preferred embodiment at least the generator and the electrical system of the support structure are constructed to be connected by an electrical connection.

[0070] The electrical connection is prepared and arranged in the modules before the modules are connected.

[0071] After the modules are connected the electrical connection can be established by connecting the prepared cables or busbars, or connecting a prepared plug and socket type connection.

[0072] Thus the connection can be established very quickly. The preparation of the connection can be performed in advance in a factory. Thus the installation time on the erection site of the wind turbine is minimized. Thus the preparation can be performed independent of the weather conditions.

[0073] In a preferred embodiment at least the cooling system in the load-carrying structure, the generator and the electrical system of the support structure are constructed to be connected by a connection for a cooling fluid.

[0074] Thus the cooling system can be connected to the generator and the electrical system. Thus the generator or the electrical system can be cooled by the cooling system.

[0075] In a preferred embodiment at least the hydraulic unit at the generator and the control system of the support structure are constructed to be connected by a hydraulic connection.

[0076] Thus the hydraulic unit and the control system can be connected by a hydraulic connection. Thus the hydraulic system can be controlled by the control system.

[0077] In a preferred embodiment at least the hydraulic unit at the generator and a hydraulic component outside of the nacelle are constructed to be connected by a hydraulic connection.

[0078] A hydraulic component outside of the nacelle is for example a hydraulic pitch system located in the hub.

[0079] Thus also hydraulic components outside of the nacelle can be connected to the hydraulic system. Thus the pitch system can be controlled hydraulically.

[0080] In a preferred embodiment at least the control system in the load-carrying structure, the generator and

the electrical system in the support structure are constructed to be connected by an electrical connection.

[0081] The electrical connection is prepared before the modules are connected. The preparation is done in a factory and in thus independent from weather conditions at the erection site of the wind turbine.

[0082] When the modules are connected the electrical connection can be established by connecting prepared cables or connecting a prepared plug and socket connection.

[0083] Thus the connection can be established very quickly. Thus installation time at the erection site of the wind turbine is saved.

[0084] In a preferred embodiment at least the control system and a component outside of the nacelle are constructed to be connected by an electrical connection.

[0085] A component outside of the nacelle that is connected to the control system is for example the hydraulic pitch system in the hub or the flight warning lights or the meteorological instruments on top of the nacelle.

[0086] The electrical connection is established in advance before the modules are transported to the erection site of the wind turbine. Thus establishing the connection is independent from the weather conditions at the erection site of the wind turbine.

[0087] The electrical connection is established at the erection site of the wind turbine after the modules are connected the connection can be achieved by connection the prepared electrical cables or connection the cables by a prepared plug and socket connection.

[0088] A nacelle for a wind turbine is assembled, wherein the separate modules and the segmented housing are connected at the erection site of the wind turbine by connecting the stationary part of the generator to the load-carrying structure. And by connecting the support structure to the load-carrying structure and connecting the segments of the housing at least to the load-carrying structure.

[0089] The invention is shown in more detail by the help of figures. The figures show a preferred configuration and do not limit the scope of the invention.

FIG 1 shows a block diagram of a nacelle and a hub of a wind turbine.

FIG 2 shows a schematic overview of an electrical power system.

FIG 3 shows a schematic overview of a cooling system.

FIG 4 shows a schematic overview of a hydraulic system.

FIG 5 shows a schematic overview of a control system.

FIG 1 shows a block diagram of a nacelle and a hub

of a wind turbine.

[0090] Three major modules of the nacelle 11, 12, 13 are connected to form the nacelle. A first module 11 comprises a generator 3. A hydraulic pump 17 is located within the stationary part of the generator 3. The generator 3 with a hydraulic module 17 is transported to an erection site of the wind turbine separate from the other parts of the nacelle 2.

[0091] A second module 12 comprises a load-carrying structure 4. The load-carrying structure comprises a yaw system 6, a control system 8 and a cooling pump 10. The load-carrying structure with the yaw system 6, the control system 8 and the cooling pump 10 is transported to an erection site of the wind turbine separate from the other modules of the nacelle.

[0092] A third module 13 comprises a support structure 5. An electrical system 7, comprising a transformer 18 and a converter 19, is connected to the support structure 5.

[0093] The support structure 5 with the electrical system 7 is transported to an erection site of the wind turbine separate from the other modules of the nacelle 2.

[0094] At the erection site of the wind turbine 1 the modules 11, 12, 13 are connected. The module 13 is connected to the module 12, whereby the support structure 5 is connected to the load-carrying structure 4.

[0095] The module 11 is connected to the module 12, whereby the generator 3 is connected to the load-carrying structure 4.

[0096] A housing 9 of the nacelle is segmented. The segments are shown by the dotted lines at the housing 9.

[0097] The segments of the housing 9 are transported to an erection site of the wind turbine separate from the other modules of the nacelle 2.

[0098] At the erection site of the wind turbine 1 the segments of the housing 9 are mounted to the modules 11, 12, 13 of the nacelle 2.

[0099] Additional components like a radiator 16 and a platform to be used with a helicopter 22 are connected to the housing 9.

[0100] A hub 14 is connected to the nacelle 2, whereby the hub 14 is connected to the rotating part of the generator 3.

[0101] FIG 2 shows a schematic overview of an electrical power system.

[0102] FIG 2 shows a nacelle 2 of a wind turbine 1 on top of a tower 29. The wind turbine is equipped with a hub 14 and rotor blades 15. On top of the nacelle is a radiator 16 of a cooling system and a platform to be used with a helicopter 22. Connections of the electrical power system are shown in a schematic way.

[0103] The electrical power system comprises an electrical connection 23 from the generator 3 to the electrical system 7, which comprises the converter 19 and the transformer 18. An electrical connection is leading from the electrical system 7 to the power grid 21.

[0104] FIG 3 shows a schematic overview of a cooling

system.

[0105] FIG 3 shows a nacelle 2 of a wind turbine 1 on top of a tower 29. The wind turbine is equipped with a hub 14 and rotor blades 15. On top of the nacelle is a radiator 16 of a cooling system and a platform to be used with a helicopter 22. Connections of the cooling system are shown in a schematic way.

[0106] The connections of the cooling system lead from a pump of the cooling system 10 to the electrical system 7 comprising the transformer 18 and the converter 19.

[0107] Another connection is leading from the cooling pump 10 to a hydraulic pump 17 in the generator and to the a bearing 20 of the wind turbine 1.

[0108] Even another connection is leading from the cooling pump 10 to the radiator 16 on top of the nacelle 2 and to a cooling connection 24 of the generator 3.

[0109] FIG 4 shows a schematic overview of a hydraulic system.

[0110] FIG 4 shows a nacelle 2 of a wind turbine 1 on top of a tower 29. The wind turbine is equipped with a hub 14 and rotor blades 15. On top of the nacelle is a radiator 16 of the cooling system and a platform to be used with a helicopter 22.

Connections of a hydraulic system are shown in a schematic way.

[0111] A hydraulic pump 17 is located in the generator 3 of the wind turbine 1. A first hydraulic connection is leading from the hydraulic pump 17 to the brakes 25 of the generator 3.

[0112] A second connection is leading from the hydraulic pump 17 to the control system 8, which is controlling the hydraulic system.

[0113] A third hydraulic connection is leading from the hydraulic pump to a hydraulic system in the hub 14 of the wind turbine 1. In this example this is the connection to a hydraulic pitch system of the rotor blades 15.

[0114] FIG 5 shows a schematic overview of a control system.

[0115] FIG 5 shows a nacelle 2 of a wind turbine 1 on top of the tower 29. The wind turbine is equipped with a hub 14 and rotor blades 15. On top of the nacelle is a radiator 16 of the cooling system and a platform to be used with a helicopter 22.

Connections of a control system are shown in a schematic way.

[0116] The control system 8 of the wind turbine 1 is located in the load-carrying structure. The control system 8 has a connection to the yaw system 6, to the converter 19 and the transformer 18.

[0117] Another connection goes from a control system 8 to the top of the nacelle 30, where meteorological instruments and flight warning lights are connected.

[0118] The control system 8 further comprises a connection 26 to the generator 3, a connection to the hydraulic pump 17 and connection to the brakes 25 of the generator 3.

[0119] Another connection leads from the control sys-

tem 8 to a component 27 in the hub 14 of the wind turbine 1. This component 27 is for example a hydraulic pitch system of the rotor blades 15 of the wind turbine 1.

Claims

1. Nacelle (2) for a wind turbine (1) comprising a generator (3), a load-carrying structure (4), a support structure (5), an electrical system (7), a yaw system (6), a control system (8) and a housing (9),
 - wherein the generator (3) comprises a rotating part and a stationary part and the stationary part is connectable to the load-carrying structure (4),
 - wherein the load-carrying structure (4) comprises the yaw system (6) and the control system (8),
 - wherein the support structure (5) comprises the electrical system (7) and the support structure (5) is connectable to the load-carrying structure (4),
 - wherein the housing (9) is segmented and is connectable to at least the load-carrying structure (4),
 - wherein the generator (3), the load-carrying structure (4) and the support structure (5) are separate modules (11, 12, 13),
 - wherein the separate modules (11, 12, 13) and the segmented housing (9) are connectable at an erection site of the wind turbine (1) to build the nacelle (2) **characterized in that**
 - the generator (3) comprises a hydraulic unit (17), which comprises a pump, mounted to the stationary part of the generator (3).
2. Nacelle (2) for a wind turbine (1) according to claim 1, wherein the load-carrying structure (4) comprises at least a part of a cooling system (10).
3. Nacelle (2) for a wind turbine (1) according to claim 2, wherein a radiator (16) is provided connectable to the housing (9).
4. Nacelle (2) for a wind turbine (1) according to one of the preceding claims, wherein the electrical system (7) comprises a transformer (18) and a converter (19), to adapt the power of the generator (3) to apply to a power grid condition of a power grid.
5. Nacelle (2) for a wind turbine (1) according to one of the preceding claims, wherein a platform to be used with a helicopter(22) is provided that is connectable to the housing (9).
6. Nacelle (2) for a wind turbine (1) according to one of the preceding claims, wherein the electrical system (7) is electrically connectable to the generator (3)

and the power grid.

7. Nacelle (2) for a wind turbine (1) according to one of the preceding claims, wherein a pipe or hose of the cooling system is connectable to the radiator (16), the generator (3) and/or the electrical system (7). 5
8. Nacelle (2) for a wind turbine (1) according to one of the preceding claims, wherein at least the generator (3) and the electrical system (7) of the support structure (5) are constructed to be connected by an electrical connection. 10
9. Nacelle (2) for a wind turbine (1) according to one of the preceding claims, wherein at least the cooling system (10) in the load-carrying structure (4), the generator (3) and the electrical system (7) of the support structure (5) are constructed to be connected by a connection for a cooling fluid. 15
10. Nacelle (2) for a wind turbine (1) according to one of the preceding claims, wherein at least the hydraulic unit (17) at the generator (3) and the control system (8) of the support structure (5) are constructed to be connected by a hydraulic connection. 20
11. Nacelle (2) for a wind turbine (1) according to one of the preceding claims, wherein at least the hydraulic unit (17) at the generator (3) and a hydraulic component (28) outside of the nacelle (2) are constructed to be connected by a hydraulic connection. 25
12. Nacelle (2) for a wind turbine (1) according to one of the preceding claims, wherein at least the control system (8) in the load-carrying structure (4), the generator (3) and the electrical system (7) in the support structure (5) are constructed to be connected by an electrical connection. 30
13. Nacelle (2) for a wind turbine (1) according to one of the preceding claims, wherein at least the control system (8) and a component (27) outside of the nacelle (2) are constructed to be connected by an electrical connection. 35
14. Method to assemble a nacelle (2) for a wind turbine (1) according to claim 1 wherein the separate modules (11, 12, 13) and the segmented housing (9) are connected at the erection site of the wind turbine (1) comprising the steps of 40
- connecting the stationary part of the generator (3) to the load-carrying structure (4),
 - connecting the support structure (5) to the load-carrying structure (4),
 - connecting the segments of the housing (9) at least to the load-carrying structure (4). 50

Patentansprüche

1. Gondel (2) für eine Windturbine (1) mit einem Generator (3), einer Tragkonstruktion (4), einer Haltekonstruktion (5), einem Elektrosystem (7), einem Windnachführungssystem (6), einem Steuersystem (8) und einem Gehäuse (9), 5
- wobei der Generator (3) einen rotierenden Teil und einen feststehenden Teil umfasst und sich der feststehende Teil mit der Tragkonstruktion (4) verbinden lässt,
 - wobei die Tragkonstruktion (4) das Windnachführungssystem (6) und das Steuersystem (8) umfasst,
 - wobei die Haltekonstruktion (5) das Elektrosystem (7) umfasst und sich mit der Tragkonstruktion (4) verbinden lässt,
 - wobei das Gehäuse (9) segmentiert ist und sich zumindest mit der Tragkonstruktion (4) verbinden lässt,
 - wobei es sich bei dem Generator (3), der Tragkonstruktion (4) und der Haltekonstruktion (5) um separate Module (11, 12, 13) handelt,
 - wobei sich die separaten Module (11, 12, 13) und das segmentierte Gehäuse (9) an einem Aufstellungsort der Windturbine (1) zum Bilden der Gondel (2) verbinden lassen, 10
- dadurch gekennzeichnet, dass**
- der Generator (3) eine Hydraulikeinheit (17) umfasst, die eine an den feststehenden Teil des Generators (3) montierte Pumpe umfasst. 15
2. Gondel (2) für eine Windturbine (1) nach Anspruch 1, bei der die Tragkonstruktion (4) zumindest einen Teil eines Kühlsystems (10) umfasst. 20
3. Gondel (2) für eine Windturbine (1) nach Anspruch 2, bei der ein Kühler (16) bereitgestellt ist, der sich mit dem Gehäuse (9) verbinden lässt. 25
4. Gondel (2) für eine Windturbine (1) nach einem der vorhergehenden Ansprüche, bei der das Elektrosystem (7) einen Transformator (18) und einen Umrichter (19) zum Anpassen der Leistung des Generators (3) an eine Stromnetzbedingung eines Stromnetzes umfasst. 30
5. Gondel (2) für eine Windturbine (1) nach einem der vorhergehenden Ansprüche, bei der eine mit einem Hubschrauber (22) benutzbare Plattform bereitgestellt ist, die sich mit dem Gehäuse (9) verbinden lässt. 35
6. Gondel (2) für eine Windturbine (1) nach einem der vorhergehenden Ansprüche, bei der sich das Elek- 40

trossystem (7) elektrisch mit dem Generator (3) und dem Stromnetz verbinden lässt.

7. Gondel (2) für eine Windturbine (1) nach einem der vorhergehenden Ansprüche, bei der sich ein Rohr oder ein Schlauch des Kühlsystems mit dem Kühler (16), dem Generator (3) und/ oder dem Elektrosystem (7) verbinden lässt. 5
8. Gondel (2) für eine Windturbine (1) nach einem der vorhergehenden Ansprüche, bei der zumindest der Generator (3) und das Elektrosystem (7) der Haltekonstruktion (5) so konstruiert sind, dass sie über eine Elektroverbindung verbunden werden. 10
9. Gondel (2) für eine Windturbine (1) nach einem der vorhergehenden Ansprüche, bei der zumindest das Kühlsystem (10) in der Tragkonstruktion (4), der Generator (3) und das Elektrosystem (7) der Haltekonstruktion (5) so konstruiert sind, dass sie über eine Verbindung für ein Kühlfluid verbunden werden. 15
10. Gondel (2) für eine Windturbine (1) nach einem der vorhergehenden Ansprüche, bei der zumindest die Hydraulikeinheit (17) am Generator (3) und das Steuersystem (8) der Haltekonstruktion (5) so konstruiert sind, dass sie über eine Hydraulikverbindung verbunden werden. 20
11. Gondel (2) für eine Windturbine (1) nach einem der vorhergehenden Ansprüche, bei der zumindest die Hydraulikeinheit (17) am Generator (3) und eine Hydraulikkomponente (28) außerhalb der Gondel (2) so konstruiert sind, dass sie über eine Hydraulikverbindung verbunden werden. 25
12. Gondel (2) für eine Windturbine (1) nach einem der vorhergehenden Ansprüche, bei der zumindest das Steuersystem (8) in der Tragkonstruktion (4), der Generator (3) und das Elektrosystem (7) in der Haltekonstruktion (5) so konstruiert sind, dass sie über eine Elektroverbindung verbunden werden. 30
13. Gondel (2) für eine Windturbine (1) nach einem der vorhergehenden Ansprüche, bei der zumindest das Steuersystem (8) und eine Komponente (27) außerhalb der Gondel (2) so konstruiert sind, dass sie über eine Elektroverbindung verbunden werden. 35
14. Verfahren zum Zusammenbauen einer Gondel (2) für eine Windturbine (1) nach Anspruch 1, bei dem die separaten Module (11, 12, 13) und das segmentierte Gehäuse (9) am Aufstellungsort der Windturbine (1) verbunden werden, mit folgenden Schritten: 40
 - Verbinden des feststehenden Teils des Generators (3) mit der Tragkonstruktion (4),
 - Verbinden der Haltekonstruktion (5) mit der

Tragkonstruktion (4),
- Verbinden der Segmente des Gehäuses (9) zumindest mit der Tragkonstruktion (4).

Revendications

1. Nacelle (2) pour une éolienne (1) comprenant un générateur (3), une structure porteuse de charge (4), une structure support (5), un système électrique (7), un système de lacet (6), un système de commande (8) et un logement (9), 5
 - dans laquelle le générateur (3) comprend une partie rotative et une partie fixe et la partie fixe est connectable à la structure porteuse de charge (4),
 - dans laquelle la structure porteuse de charge (4) comprend le système de lacet (6) et le système de commande (8),
 - dans laquelle la structure support (5) comprend le système électrique (7) et la structure support (5) est connectable à la structure porteuse de charge (4),
 - dans laquelle le logement (9) est segmenté et est connectable à au moins la structure porteuse de charge (4),
 - dans laquelle le générateur (3), la structure porteuse de charge (4) et la structure support (5) sont des modules séparés (11, 12, 13),
 - dans laquelle les modules séparés (11, 12, 13) et le logement (9) segmenté sont connectables sur un site d'érection de l'éolienne (1) pour construire la nacelle (2) 10

caractérisée en ce que

- le générateur (3) comprend une unité hydraulique (17), qui comprend une pompe, montée sur la partie fixe du générateur (3). 15
2. Nacelle (2) pour une éolienne (1) selon la revendication 1, dans laquelle la structure porteuse de charge (4) comprend au moins une partie d'un système de refroidissement (10). 20
 3. Nacelle (2) pour une éolienne (1) selon la revendication 2, dans laquelle un radiateur (16) est prévu connectable au logement (9). 25
 4. Nacelle (2) pour une éolienne (1) selon l'une des revendications précédentes, dans laquelle le système électrique (7) comprend un transformateur (18) et un convertisseur (19), pour adapter la puissance du générateur (3) pour application à une condition de réseau électrique d'un réseau électrique. 30
 5. Nacelle (2) pour une éolienne (1) selon l'une des

revendications précédentes, dans laquelle une plate-forme destinée à être utilisée avec un hélicoptère (22) est prévue, qui est connectable au logement (9).

6. Nacelle (2) pour une éolienne (1) selon l'une des revendications précédentes, dans laquelle le système électrique (7) est électriquement connectable au générateur (3) et au réseau électrique. 5
7. Nacelle (2) pour une éolienne (1) selon l'une des revendications précédentes, dans laquelle un tuyau ou un tuyau souple du système de refroidissement est connectable au radiateur (16), au générateur (3) et/ou au système électrique (7). 10
8. Nacelle (2) pour une éolienne (1) selon l'une des revendications précédentes, dans laquelle au moins le générateur (3) et le système électrique (7) de la structure support (5) sont construits pour être connectés par une connexion électrique. 15 20
9. Nacelle (2) pour une éolienne (1) selon l'une des revendications précédentes, dans laquelle au moins le système de refroidissement (10) dans la structure porteuse de charge (4), le générateur (3) et le système électrique (7) de la structure support (5) sont construits pour être connectés par une connexion pour un fluide de refroidissement. 25
10. Nacelle (2) pour une éolienne (1) selon l'une des revendications précédentes, dans laquelle au moins l'unité hydraulique (17) au niveau du générateur (3) et le système de commande (8) de la structure support (5) sont construits pour être connectés par une connexion hydraulique. 30 35
11. Nacelle (2) pour une éolienne (1) selon l'une des revendications précédentes, dans laquelle au moins l'unité hydraulique (17) au niveau du générateur (3) et un composant hydraulique (28) à l'extérieur de la nacelle (2) sont construits pour être connectés par une connexion hydraulique. 40
12. Nacelle (2) pour une éolienne (1) selon l'une des revendications précédentes, dans laquelle au moins le système de commande (8) dans la structure porteuse de charge (4), le générateur (3) et le système électrique (7) dans la structure support (5) sont construits pour être connectés par une connexion électrique. 45 50
13. Nacelle (2) pour une éolienne (1) selon l'une des revendications précédentes, dans laquelle au moins le système de commande (8) et un composant (27) à l'extérieur de la nacelle (2) sont construits pour être connectés par une connexion électrique. 55
14. Procédé d'assemblage d'une nacelle (2) pour une

éolienne (1) selon la revendication 1 dans lequel les modules séparés (11, 12, 13) et le logement (9) segmenté sont connectés au niveau du site d'érection de l'éolienne (1) comprenant les étapes de

- connexion de la partie fixe du générateur (3) à la structure porteuse de charge (4),
- connexion de la structure support (5) à la structure porteuse de charge (4),
- connexion des segments du logement (9) au moins à la structure porteuse de charge (4).

FIG 1

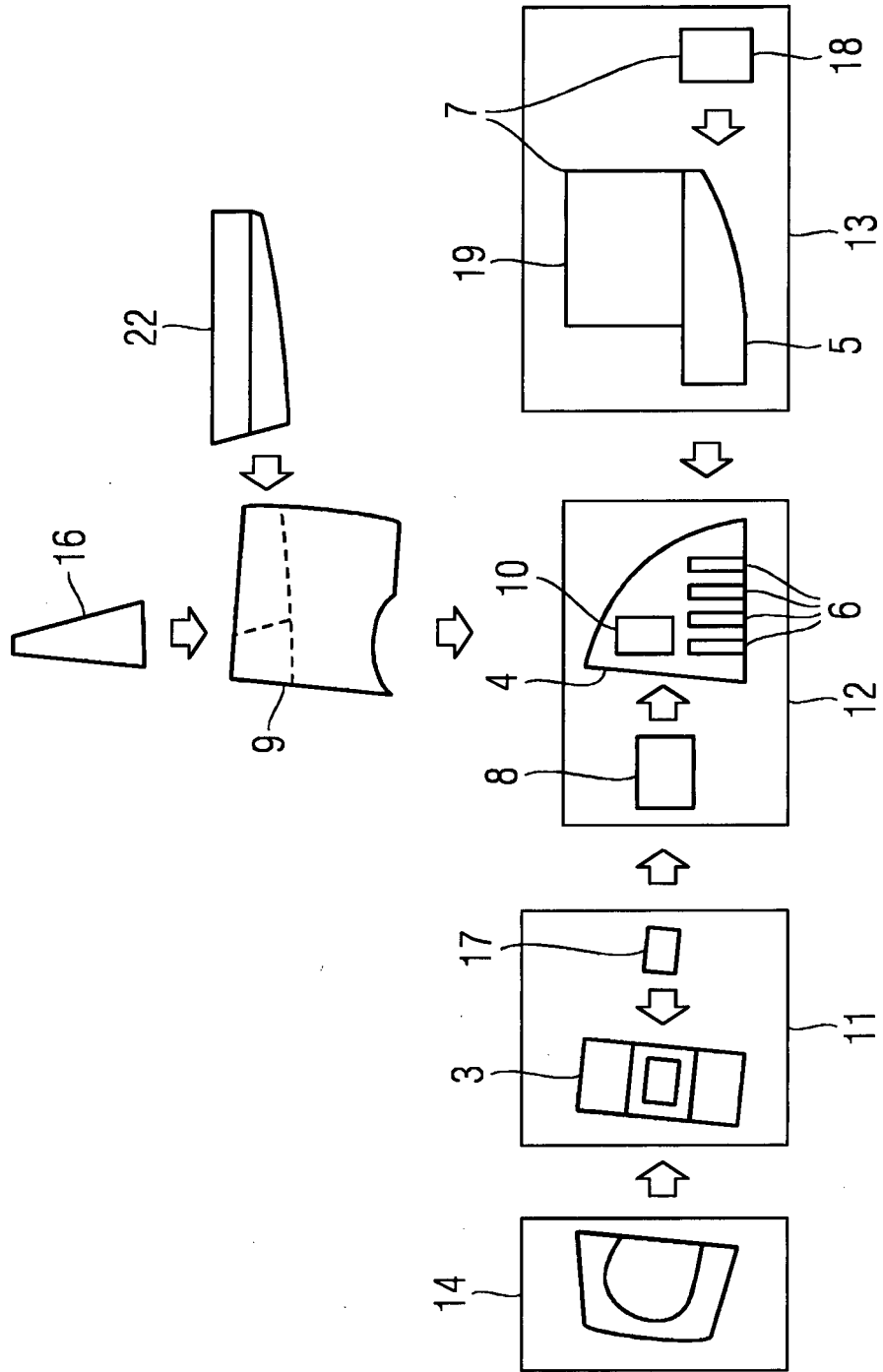

FIG 2

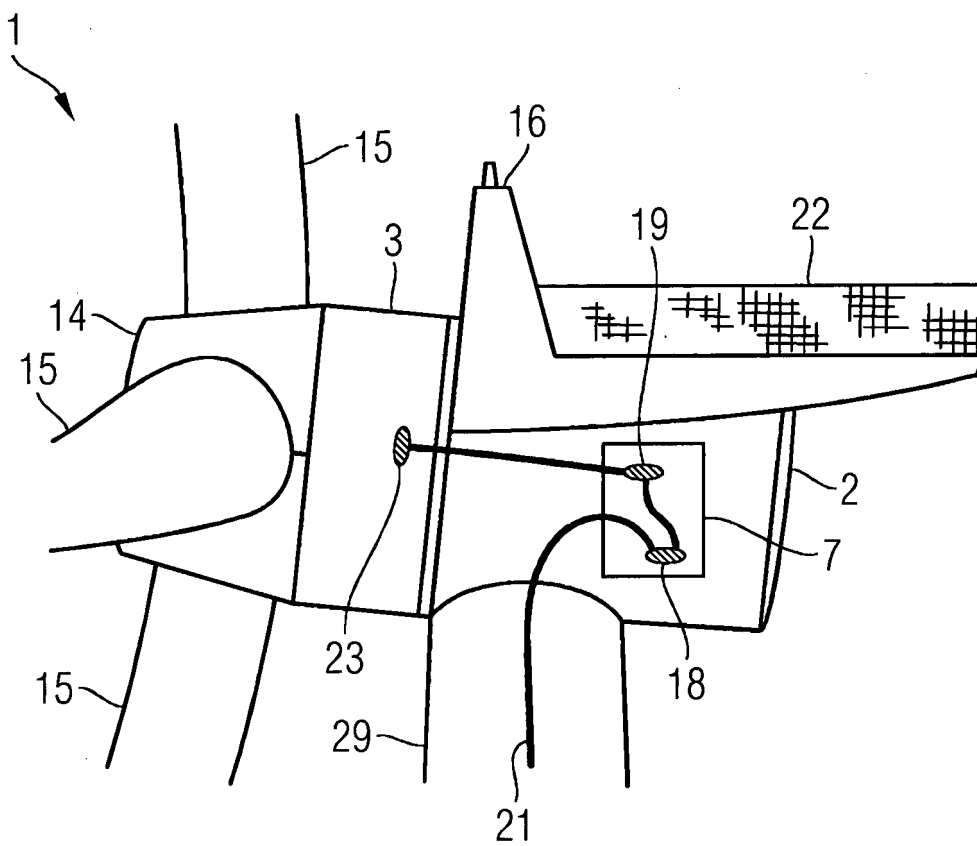

FIG 3

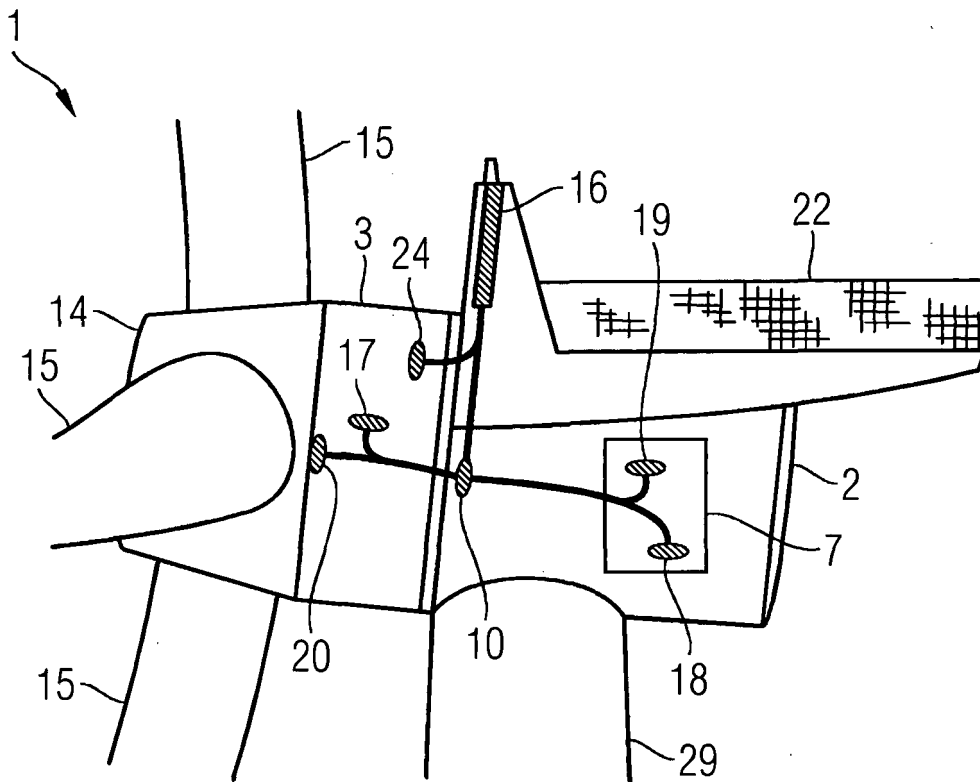

FIG 4

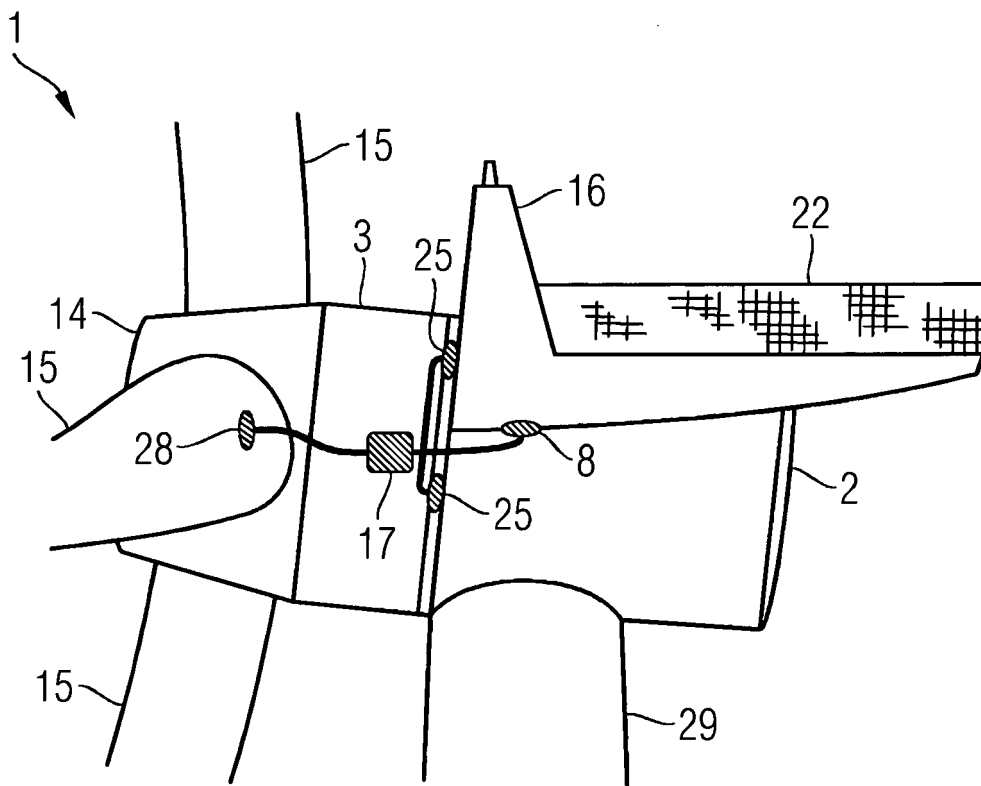
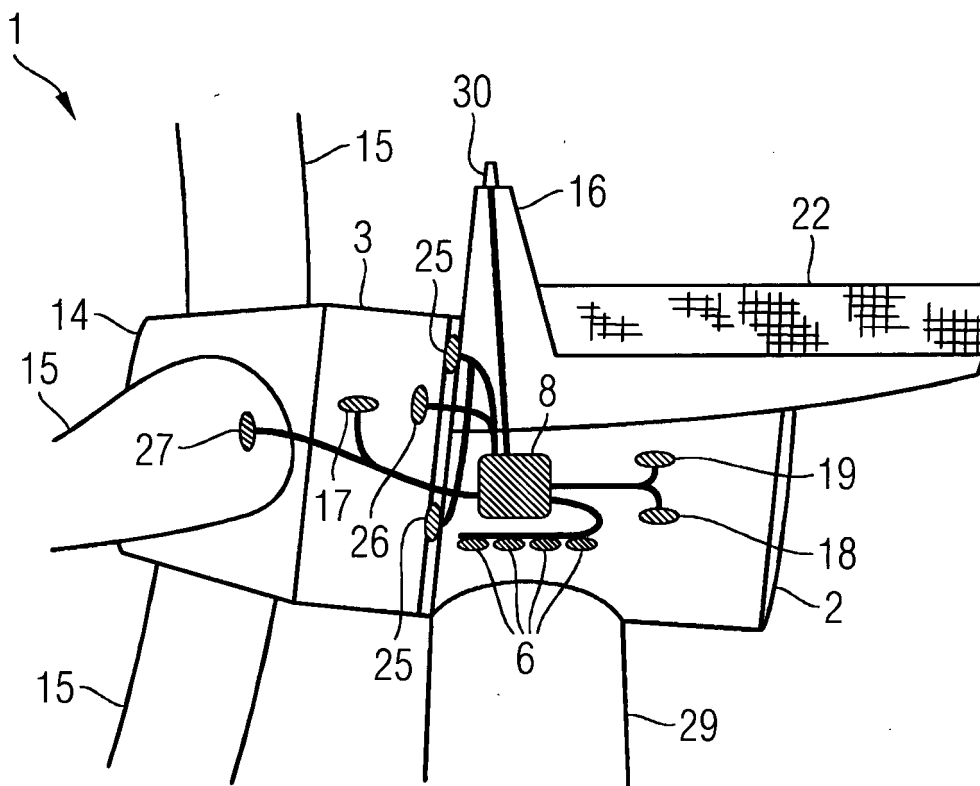

FIG 5



REFERENCES CITED IN THE DESCRIPTION

This list of references cited by the applicant is for the reader's convenience only. It does not form part of the European patent document. Even though great care has been taken in compiling the references, errors or omissions cannot be excluded and the EPO disclaims all liability in this regard.

Patent documents cited in the description

- EP 2063119 A [0010]