

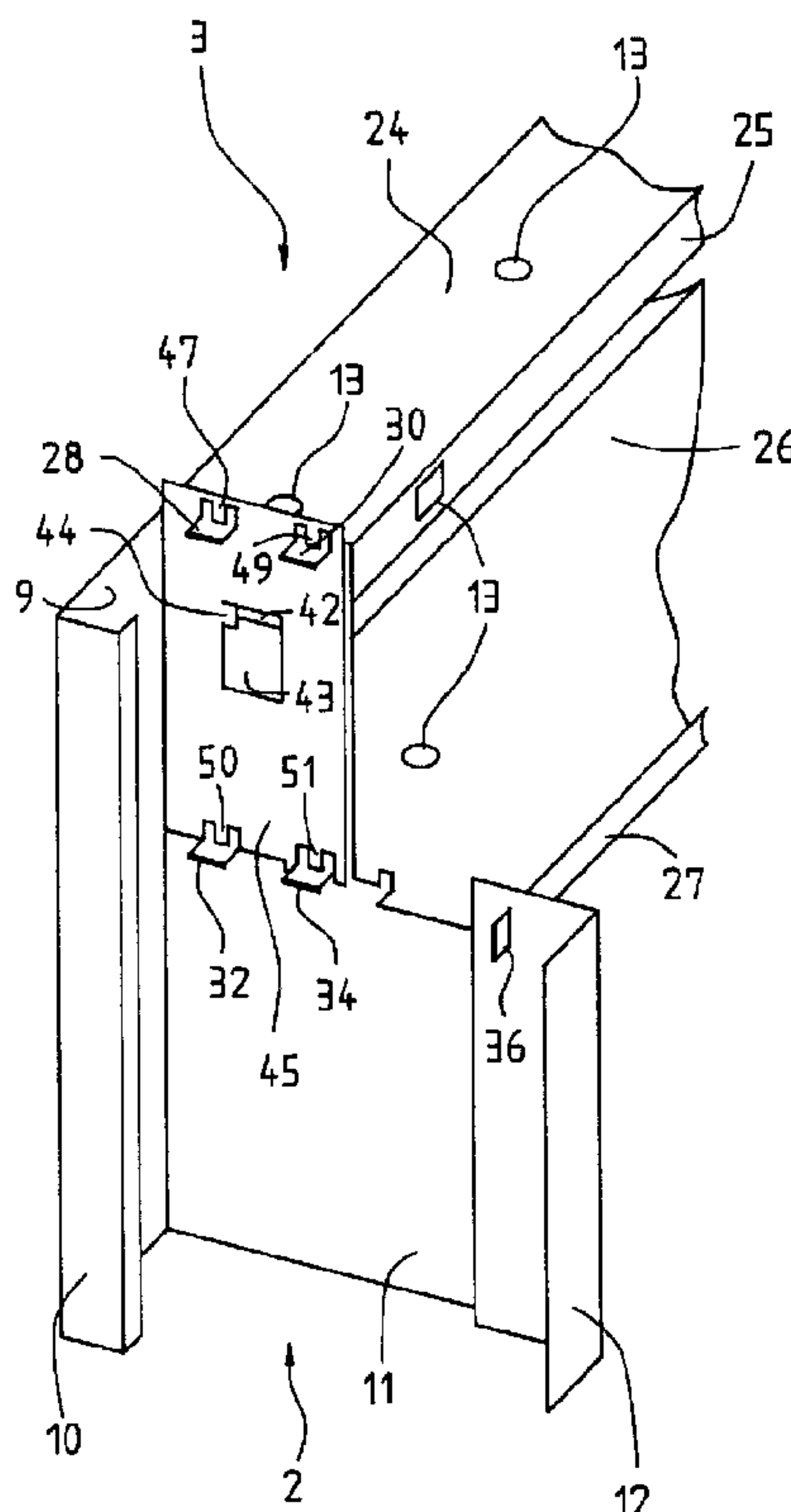

(22) Date de dépôt/Filing Date: 1997/05/12
 (41) Mise à la disp. pub./Open to Public Insp.: 1997/11/12
 (45) Date de délivrance/Issue Date: 2005/08/23
 (30) Priorité/Priority: 1996/05/13 (96 810300.2) EP

(51) Cl.Int.⁶/Int.Cl.⁶ E06B 1/12
 (72) Inventeurs/Inventors:
 REITZ, RAYMOND, FR;
 DUBREUIL, PATRICK, FR
 (73) Propriétaire/Owner:
 INVENTIO AG, CH
 (74) Agent: RICHES, MCKENZIE & HERBERT LLP

(54) Titre : CADRE DE PORTE
 (54) Title: DOOR FRAME



(57) Abrégé/Abstract:

In this door frame, frame elements are connected together mechanically positively and non-detachably in pluggable manner. Tongues (28, 30, 32, 34) of a lintel element (3) are plugged into slots (37, 38, 39, 40) of a door post (2) and additional element (45) is pushed at the door post end onto the tongues (28, 30, 32, 34), which project out of the slots of the door post (2), of the lintel element (3). Thereafter, the additional element (45) is moved downwardly, wherein tongues (47, 49, 50, 51) of the additional element (45) detent in slots (29, 31, 33, 35) of the lintel element (3). The upward movement of the additional element (45) is prevented by means of a tongue (44) in that this is bent into a recess (42) of the door post (2).

Abstract:

In this door frame, frame elements are connected together mechanically positively and non-detachably in pluggable manner. Tongues (28, 30, 32, 34) of a lintel element (3) are plugged into slots (37, 38, 39, 40) of a door post (2) and additional element (45) is pushed at the door post end onto the tongues (28, 30, 32, 34), which project out of the slots of the door post (2), of the lintel element (3). Thereafter, the additional element (45) is moved downwardly, wherein tongues (47, 49, 50, 51) of the additional element (45) detent in slots (29, 31, 33, 35) of the lintel element (3). The upward movement of the additional element (45) is prevented by means of a tongue (44) in that this is bent into a recess (42) of the door post (2).

(Fig. 7)

Description:

Door Frame

- 5 The invention relates to a door frame consisting of frame elements, which are connectible by means of connecting means.

10 Frame elements for a door, which are detachably connected by means of a connecting bracket, have become known from published specification WO 95/32912. Two door posts and a transom element form the door frame. The L-shaped connecting bracket has bores at a long limb and elongate slots at a short limb. The long limb of the connecting bracket is screw-connected with a further connecting bracket, which is connected with a door post and additionally stiffens this. The transom element, at which a door drive is arranged, stands in screw
15 connection with the long limb and with the short limb of the connecting bracket. A further connecting bracket with elongate slots, by means of which the frame construction is fixed to a wall, is screw-fastened to the short limb.

20 A disadvantage of the known equipment is that connecting brackets, which are expensive in manufacture and cause a high assembly effort, are necessary for the connection of the frame elements. It is also a disadvantage that the screws and nuts used as connecting means can loosen, which can have serious consequences, for example in the case of a frame for a lift door.

25 The invention is to create a remedy here. The invention meets the object of avoiding the disadvantages of the known equipment and of proposing a door frame with pluggable frame elements which are non-detachably connected together.

30 The advantages achieved by the invention are to be seen essentially in that expensive assembly operations such as welding, screwing, riveting and so forth become superfluous and thus substantial assembly costs can be saved. Moreover, the door frame according to the invention can be built more precisely without the assembly gauges necessary for the conventional connecting means, because the
35 frame elements with their fixings are mechanically producible in one piece. Thanks

to the simple manner of connection, the door frame is lighter, can be transported disassembled and put together on site.

In one aspect, the present invention resides in a door frame comprising: a threshold element extending between a bottom of a pair of door posts and a lintel element extending between a top of said door posts; a first connecting means for connecting said threshold element to said door posts, said first connecting means including at least one pair of deformable threshold tongues formed on one of said threshold element and a first one of said door posts and a corresponding threshold recess formed in another one said threshold element and said first door post whereby said threshold tongues are inserted into said threshold recess and deformed to mechanically connect said threshold element with said first door post; and a second connecting means for connecting said lintel element to said door posts, said second connecting means including at least one deformable lintel tongue formed on said lintel element and a corresponding lintel slot formed in said first door post whereby said lintel tongue is inserted into said lintel slot and deformed to mechanically connect said lintel element with said first door post.

In another aspect, the present invention resides in a door frame comprising: a threshold element extending between a bottom of a pair of door posts and a lintel element extending between a top of said door posts; a first connecting means for connecting said threshold element to said door posts, said first connecting means including at least one deformable threshold tongue formed on one of said threshold element and a first one of said door posts and a corresponding one of a threshold slot and a threshold recess formed in another one said threshold element and said first door post whereby said threshold tongues are inserted into said corresponding one of said threshold slot and said threshold recess and deformed to mechanically connect said threshold element with said first door post; a second connecting means for connecting said lintel element to said door posts, said second connecting means including at least one deformable lintel tongue formed on said lintel element and a corresponding lintel slot formed in said first door post whereby said lintel tongue is inserted into said lintel slot and deformed to mechanically connect said lintel element with said first door post; and an additional element having at least one deformable additional element tongue formed thereon and

2a

wherein said lintel element has at least one additional element slot formed therein whereby said additional element is positioned on an opposite side of said first door post from said lintel element and said additional element tongue is inserted into said additional slot and deformed to mechanically connect said lintel element with said first door post.

In a further aspect, the present invention resides in a door frame comprising: a threshold element extending between a bottom of a pair of door posts and a lintel element extending between a top of said door posts; a first connecting means for connecting said threshold element to said door posts, said first connecting means including at least one pair of deformable threshold tongues formed on one of said threshold element and a first one of said door posts and a corresponding threshold recess formed in another one of said threshold element and said first door post whereby said threshold tongues are inserted into said threshold recess and deformed to mechanically connect said threshold element with said first door post; a second connecting means for connecting said lintel element to said door posts, said second connecting means including at least one deformable lintel tongue formed on said lintel element and a corresponding lintel slot formed in said first door post whereby said lintel tongue is inserted into said lintel slot and deformed to mechanically connect said lintel element with said first door post; and an additional element having at least one deformable additional element tongue formed thereon and wherein said lintel element has at least one additional element slot formed therein whereby said additional element is positioned on an opposite side of said first door post from said lintel element and said additional element tongue is inserted into said additional slot and deformed to mechanically connect said lintel element with said first door post.

The invention is explained more closely in the following by reference to drawings illustrating merely one manner of execution, in which:

Fig. 1 shows two frame elements to be connected together,

Fig. 2 shows the two frame elements according to Fig. 1 in connection with one another,

2b

Fig. 3 and Fig. 4

show details of the connected frame elements according to Fig. 2,

Fig. 5 shows a variant of embodiment of the frame elements to be connected,

Fig. 6 shows the two frame elements according to Fig. 5 in connection with one another,

Fig. 7 shows a further variant of embodiment of the frame elements to be connected,

Fig. 8 shows the two frame elements according to Fig. 7 in conjunction with an additional element,

Fig. 9 shows the two frame elements secured by means of the additional element according to Fig. 8,

Fig. 10 shows a plan view of a tongue of the additional element, and

Fig. 11 shows a side elevation of the tongue shown in Fig. 10.

A door frame consisting of four frame elements is illustrated in Figs. 1 to 11, wherein a threshold element 1 at the bottom, a door post 2 for each side and a lintel element 3 at the top are provided as frame elements and wherein the door

posts 2 stand on the threshold element 1 and the lintel element 3 is arranged between the door posts 2.

In Figs. 1 to 4, the threshold element 1 has a U-shaped profile section with a base 4, with a first collar 5 of a first longitudinal side 6 and with a second collar 7 of a second longitudinal side 8. The door post 2 is L-shaped and has a third collar 10 at a first limb 9 and a fourth collar 12 at a second limb 11. Recesses, which are necessary for assembly, at the threshold element 1, at the door post 2 and at the lintel element 3 are denoted by 13. A first tongue 14 is arranged at the third collar 10 of the door post 2 and a second tongue 15 is arranged at the second limb 11 of the door post 2. In that corner of the door post 2 which is formed by the first limb 9 and the second limb 11 an incision 16 is provided at the level of the first longitudinal side 6 of the threshold element 1. The base 4 of the threshold element 1 has a first slot 17 and the second collar 7 has a second slot 18. The first collar 5 of the first longitudinal side 6 is cut back in the width of the first limb 9 of the door post 2.

During assembly, the first tongue 14 is plugged into the first slot 17 and the second tongue 15 into the second slot 18, wherein the first limb 9 of the door post 2 engages behind the longitudinal side 6 of the threshold element 1 in the cut-back region of the first collar 5. Then, the first tongue 14 and the second tongue 15 are deformed as shown in Figs. 3 and 4, whereby the threshold element 1 is mechanically positively and non-detachably connected with the door post 2.

A further variant for the connection of the threshold element 1 with the door post 2 is illustrated in Figs. 5 and 6. The first limb 9 has a first double tongue 19 and the second limb 11 of the door post 2 has a second double tongue 20. A first recess 21, which fits the first double tongue 19, is arranged at the first longitudinal side 6 of the threshold element 1. A first bracket 22, which is punched out of the base 4 of the threshold element 1, has a second recess 23 fitting the second double tongue 20. During assembly, the double tongues 19 and 20 are plugged through the recesses 21 and 23 and deformed as shown in Fig. 6, whereby the threshold element 1 is mechanically positively and non-detachably connected with the door post 2.

In a further variant for the connection of the threshold element 1 with the door post 2, the connection variant of Figs. 1 to 4 can be combined with the connection variant of Figs. 5 and 6.

5 An example of embodiment for the connection of the door post 2 with the lintel element 3 is shown in Figs. 7 to 9. The U-shaped lintel element 3 has a third longitudinal side 24 with a third collar 25 and a fourth longitudinal side 26 with a fourth collar 27. At the end face, the third longitudinal side 24 has a third tongue 28 with a third slot 29 and a fourth tongue 30 with a fourth slot 31. At the end face, the
10 fourth longitudinal side 26 has a fifth tongue 32 with fifth slot 33 and a sixth tongue 34 with a sixth slot 35. At the end face, the fourth collar 27 has a seventh tongue 26.

The lintel-side end of the door post 2 has a second slot 37, an eighth slot 38, a
15 ninth slot 39, a tenth slot 40 and an eleventh slot 41, wherein the seventh slot 37 fits the third tongue 28, the eighth slot 38 fits the fourth tongue 30, the ninth slot 39 fits the fifth tongue 32, the tenth slot 40 fits the sixth tongue 34 and the eleventh slot 41 fits the seventh tongue 36.

20 A third recess 42, which fits a fourth recess 43 with an eighth tongue 44 of an additional element 45, is arranged at the door post 2. A fifth recess 46 with a ninth tongue 47, a sixth recess 48 with a tenth tongue 49, an eleventh tongue 50 and a twelfth tongue 51 are arranged at the additional element 45, wherein the tongues and slots fit the tongues and slots of the lintel element 3.

25

During assembly, the tongues of the lintel element 3 are plugged into the slots of the door post 2 and the additional element 45 is pushed at the door post end onto the tongues of the lintel element 3, which project out of the slots 37, 38, 39 and 40 of the door post 2, as shown in Figs. 8 and 9. Thereafter, the additional element 45
30 is moved downwardly, wherein the tongues 47, 49, 50 and 51 of the additional element 45 detent in the slots 29, 31, 33 and 35 of the lintel element 3. The upward movement of the additional element 45 is prevented by means of the eighth tongue 44 in that this is bent into the third recess 42 of the door post 2. The seventh tongue 36 is deformed at the door post end. The pluggable connection
35 between the door post 2 and the lintel element 3 is mechanically positive and non-detachable.

Fig. 10 shows a tongue 50 of the additional element 45. The tongue 50 is reduced in width towards its free end, i.e. it is slightly wedge-shaped. As shown in Fig. 11, the free end of the tongue 50 can also be shaped to be slightly wedge-shaped in thickness by flattening-off by means of the punching tool. The remaining tongues 5
44, 47, 49 and 51 of the additional element 45 are constructed like the tongue 50. The tongues 44, 47, 49, 50 and 51, which are wedge-shaped in width and/or thickness, enable an easy introduction of the tongues 44, 47, 49, 50 and 51 into the slots 29, 31, 22, 35 and 42. Production tolerances can also be compensated
10 for the wedge-shaped tongues 44, 47, 49, 50 and 51.

Claims

1. A door frame comprising:

a threshold element (1a) extending between a bottom of a pair of door posts (2a) and a lintel element (3) extending between a top of said door posts;

a first connecting means for connecting said threshold element (1a) to said door posts (2a), said first connecting means including at least one pair of deformable threshold tongues (19, 20) formed on one of said threshold element and a first one of said door posts and a corresponding threshold recess (21, 23) formed in another one said threshold element and said first door post whereby said threshold tongues are inserted into said threshold recess and deformed to mechanically connect said threshold element with said first door post; and

a second connecting means for connecting said lintel element (3) to said door posts (2a), said second connecting means including at least one deformable lintel tongue (28, 30, 32, 34, 36) formed on said lintel element and a corresponding lintel slot (37, 38, 39, 40, 41) formed in said first door post whereby said lintel tongue is inserted into said lintel slot and deformed to mechanically connect said lintel element with said first door post.

2. A door frame comprising:

a threshold element (1, 1a) extending between a bottom of a pair of door posts (2, 2a) and a lintel element (3) extending between a top of said door posts;

a first connecting means for connecting said threshold element (1, 1a) to said door posts (2, 2a), said first connecting means including at least one deformable threshold tongue (14, 15, 19, 20) formed on one of said threshold element and a first one of said door posts and a corresponding one of a threshold slot (17, 18) and a threshold recess (21, 23) formed in another one said threshold element and said first door post whereby said threshold tongues are inserted into said corresponding one of said threshold slot and said threshold recess and deformed to mechanically connect said threshold element with said first door post;

a second connecting means for connecting said lintel element (3) to said door posts (2a), said second connecting means including at least one deformable lintel tongue (28, 30, 32, 34, 36) formed on said lintel element and a corresponding lintel slot (37, 38, 39, 40, 41) formed in said first door post whereby said lintel

tongue is inserted into said lintel slot and deformed to mechanically connect said lintel element with said first door post; and

an additional element (45) having at least one deformable additional element tongue (47, 49, 50, 51) formed thereon and wherein said lintel element (3) has at least one additional element slot (29, 31, 33, 35) formed therein whereby said additional element is positioned on an opposite side of said first door post from said lintel element and said additional element tongue is inserted into said additional slot and deformed to mechanically connect said lintel element with said first door post.

3. A door frame comprising:

a threshold element (1a) extending between a bottom of a pair of door posts (2a) and a lintel element (3) extending between a top of said door posts;

a first connecting means for connecting said threshold element (1a) to said door posts (2a), said first connecting means including at least one pair of deformable threshold tongues (19, 20) formed on one of said threshold element and a first one of said door posts and a corresponding threshold recess (21, 23) formed in another one of said threshold element and said first door post whereby said threshold tongues are inserted into said threshold recess and deformed to mechanically connect said threshold element with said first door post;

a second connecting means for connecting said lintel element (3) to said door posts (2a), said second connecting means including at least one deformable lintel tongue (28, 30, 32, 34, 36) formed on said lintel element and a corresponding lintel slot (37, 38, 39, 40, 41) formed in said first door post whereby said lintel tongue is inserted into said lintel slot and deformed to mechanically connect said lintel element with said first door post; and

an additional element (45) having at least one deformable additional element tongue (47, 49, 50, 51) formed thereon and wherein said lintel element (3) has at least one additional element slot (29, 31, 33, 35) formed therein whereby said additional element is positioned on an opposite side of said first door post from said lintel element and said additional element tongue is inserted into said additional slot and deformed to mechanically connect said lintel element with said first door post.

4. The door frame according to claim 3 wherein said threshold tongue (19, 20) is formed integral with said first door post (2a) and said threshold recess (21, 23) is formed in said threshold element.

5. The door frame according to claim 3 wherein said additional element (45) has a post tongue (44) formed thereon and said first door post (2a) has a post recess (42) formed therein whereby said post tongue is inserted into said post recess and deformed to mechanically connect said additional element with said first door post.

6. The door frame according to claim 3 wherein additional element tongues (47, 49, 50, 51) are reduced in at least one of width and thickness towards a free end thereof.

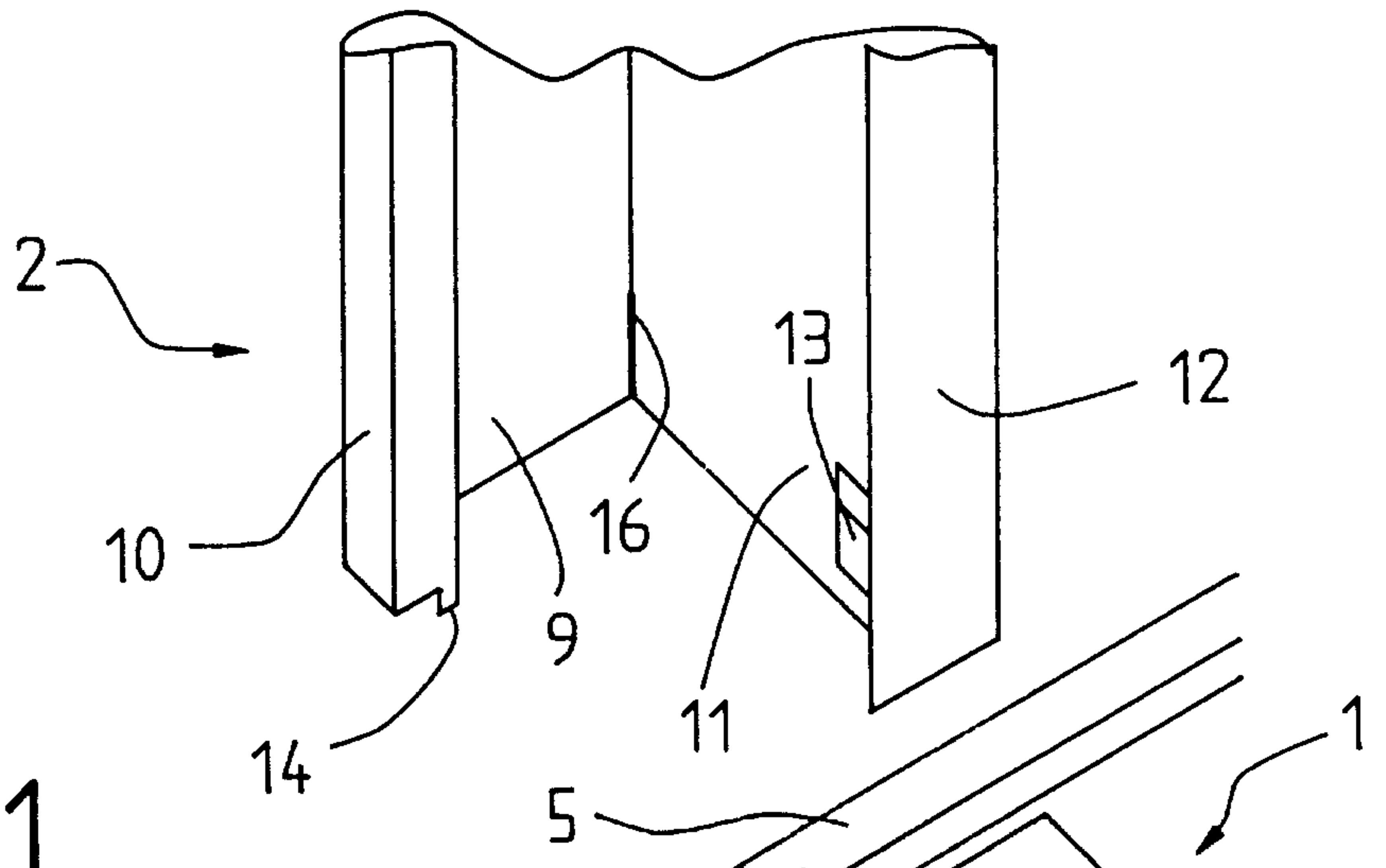

Fig. 1

Fig. 2

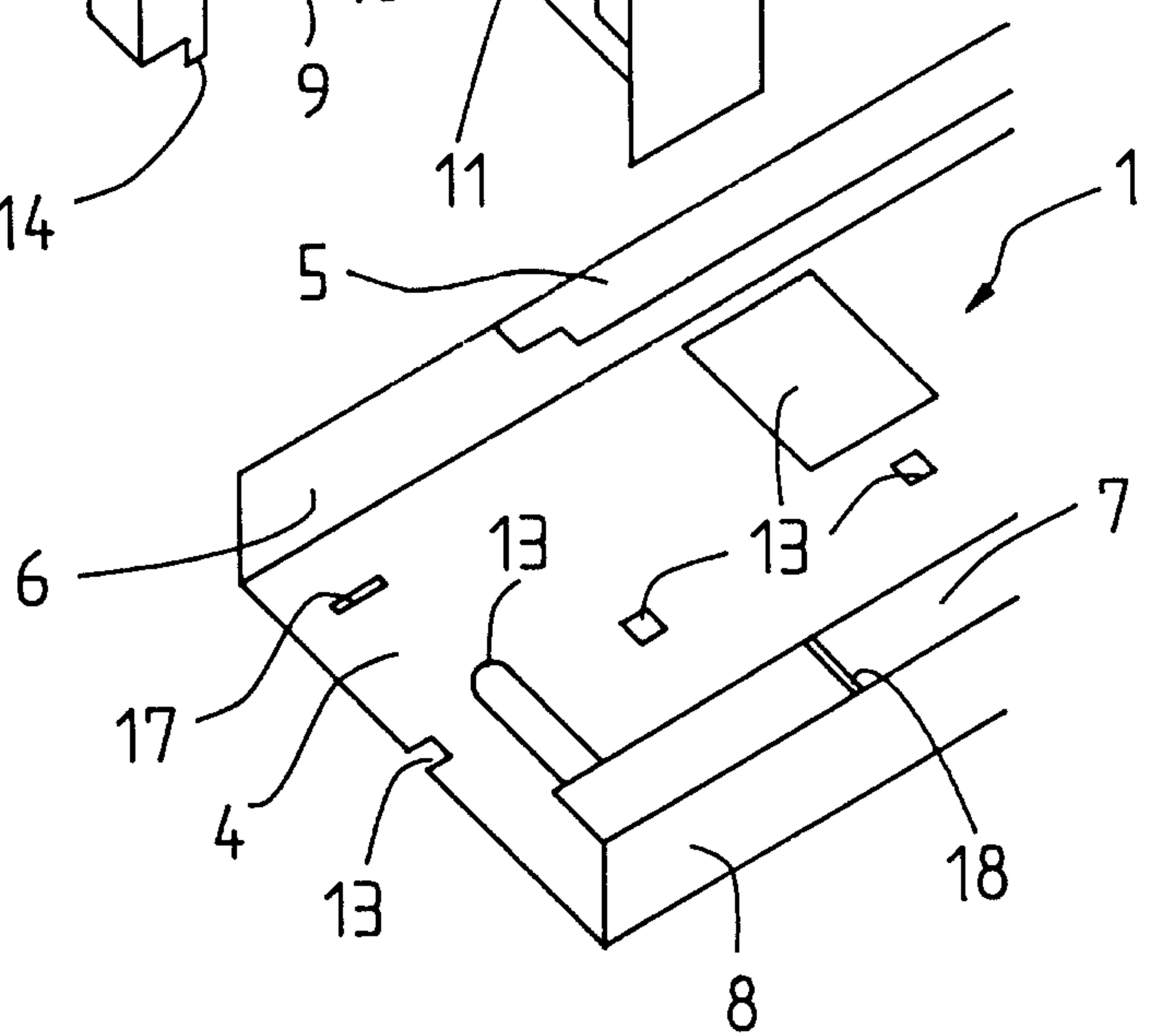
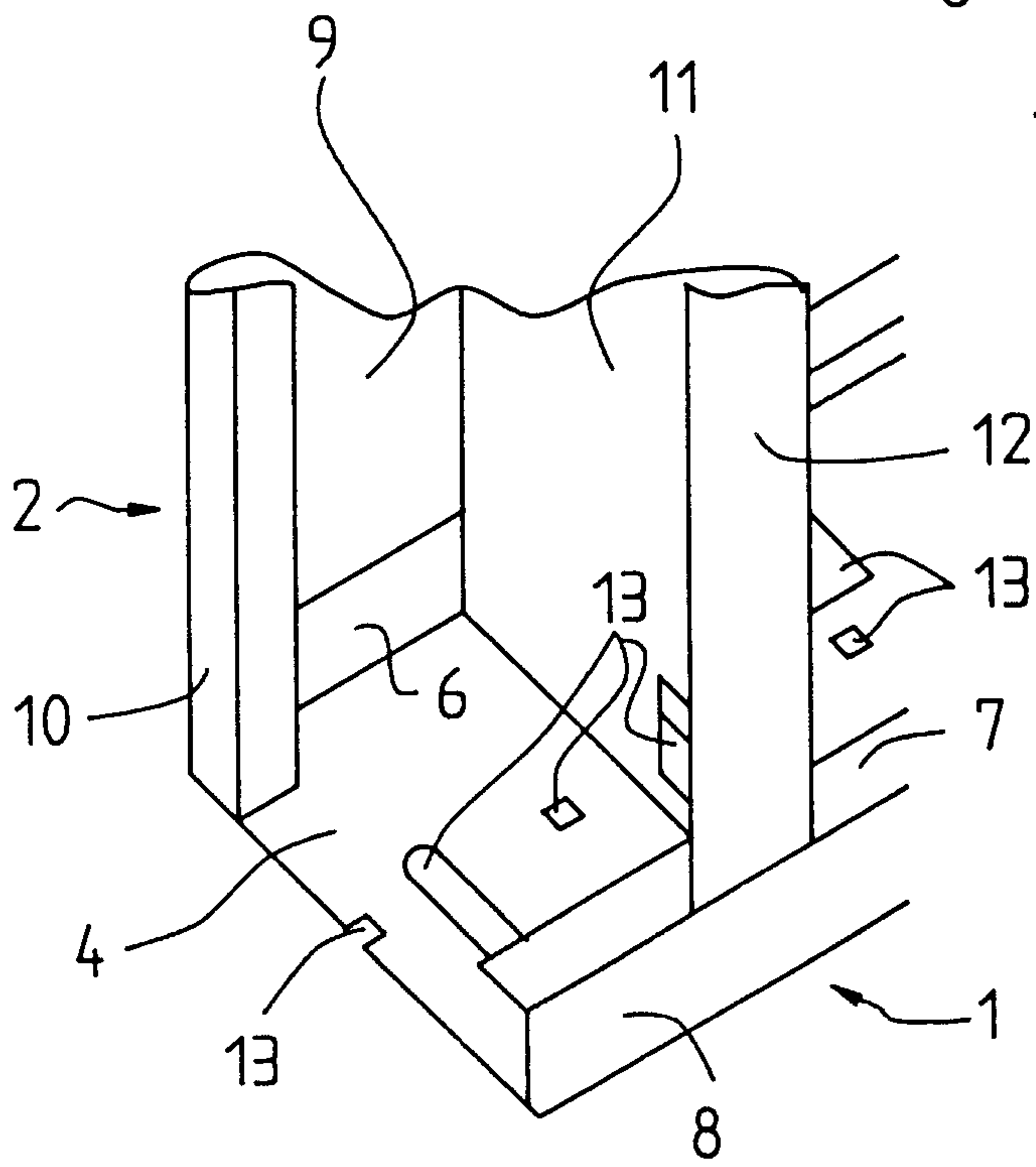

Fig. 3

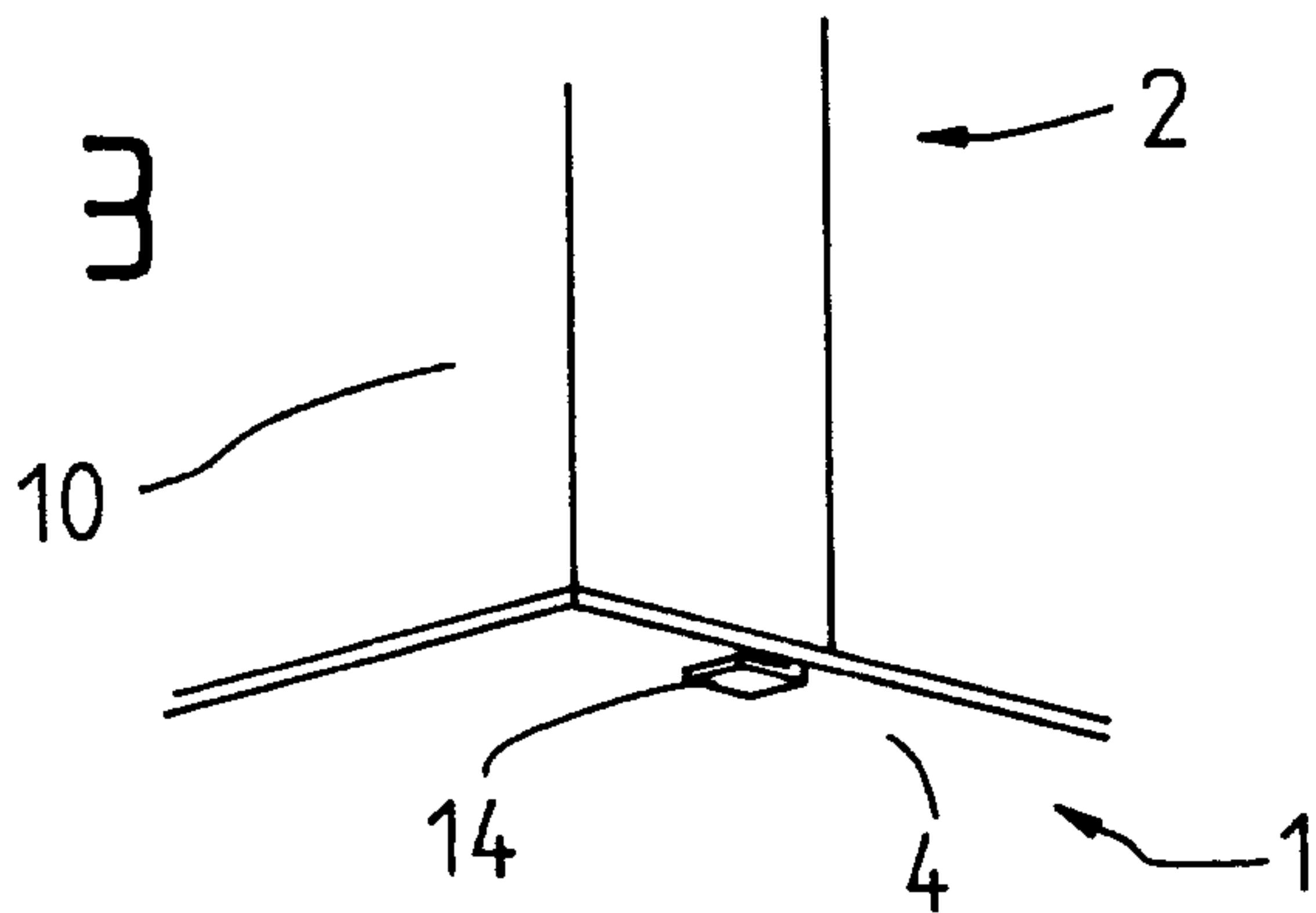

Fig. 4

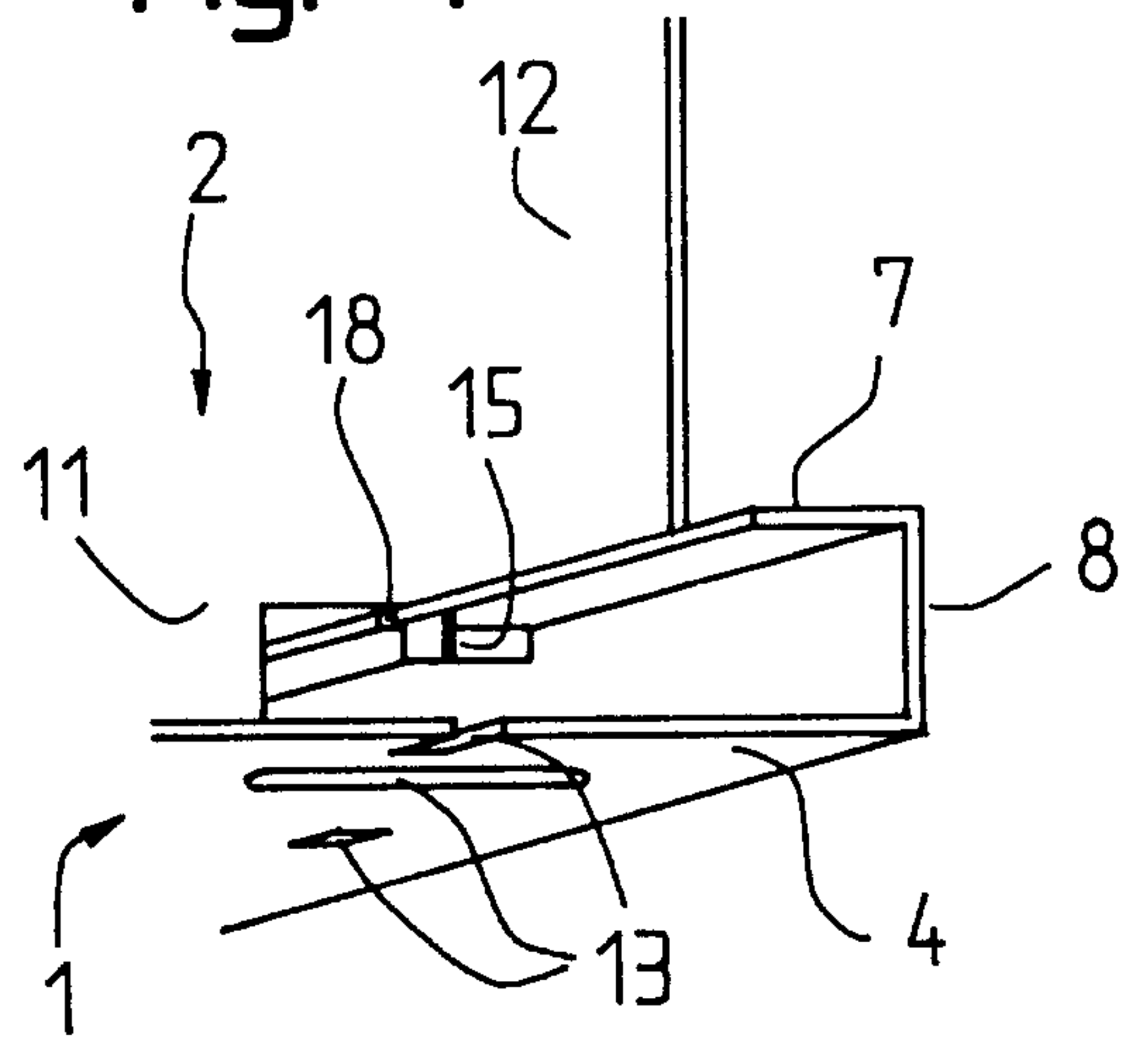

Fig. 5

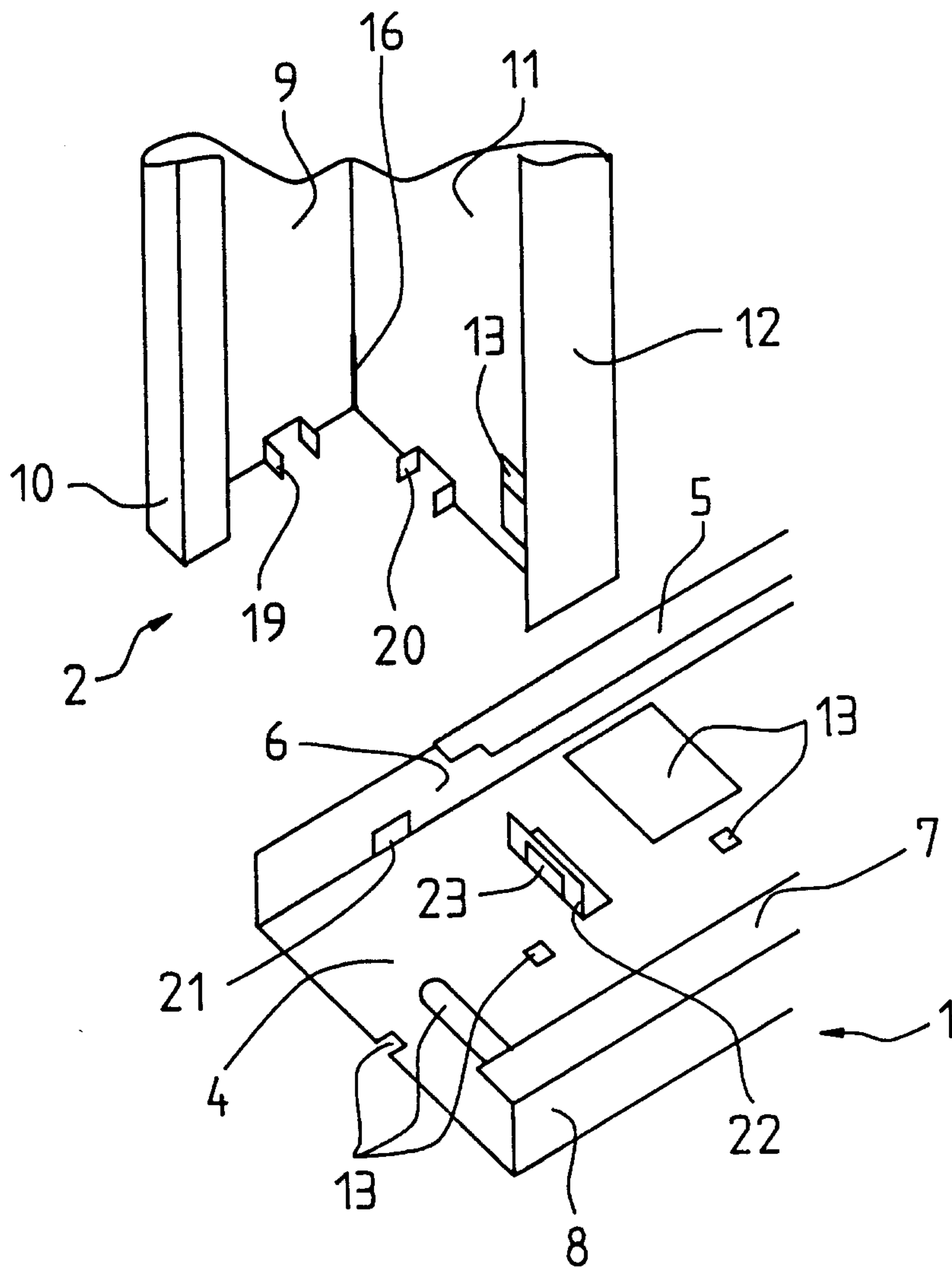

Fig. 6

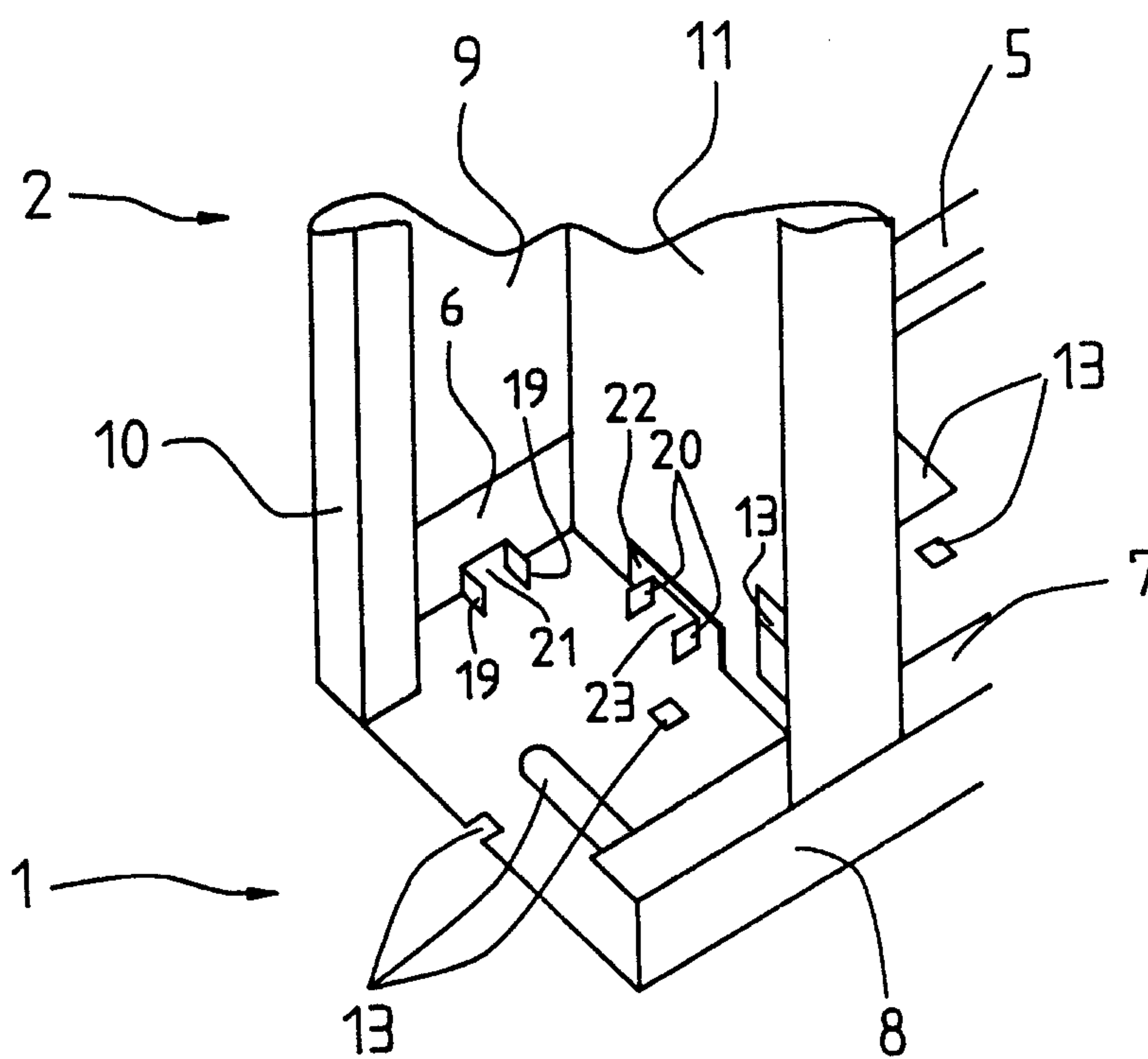

Fig. 7

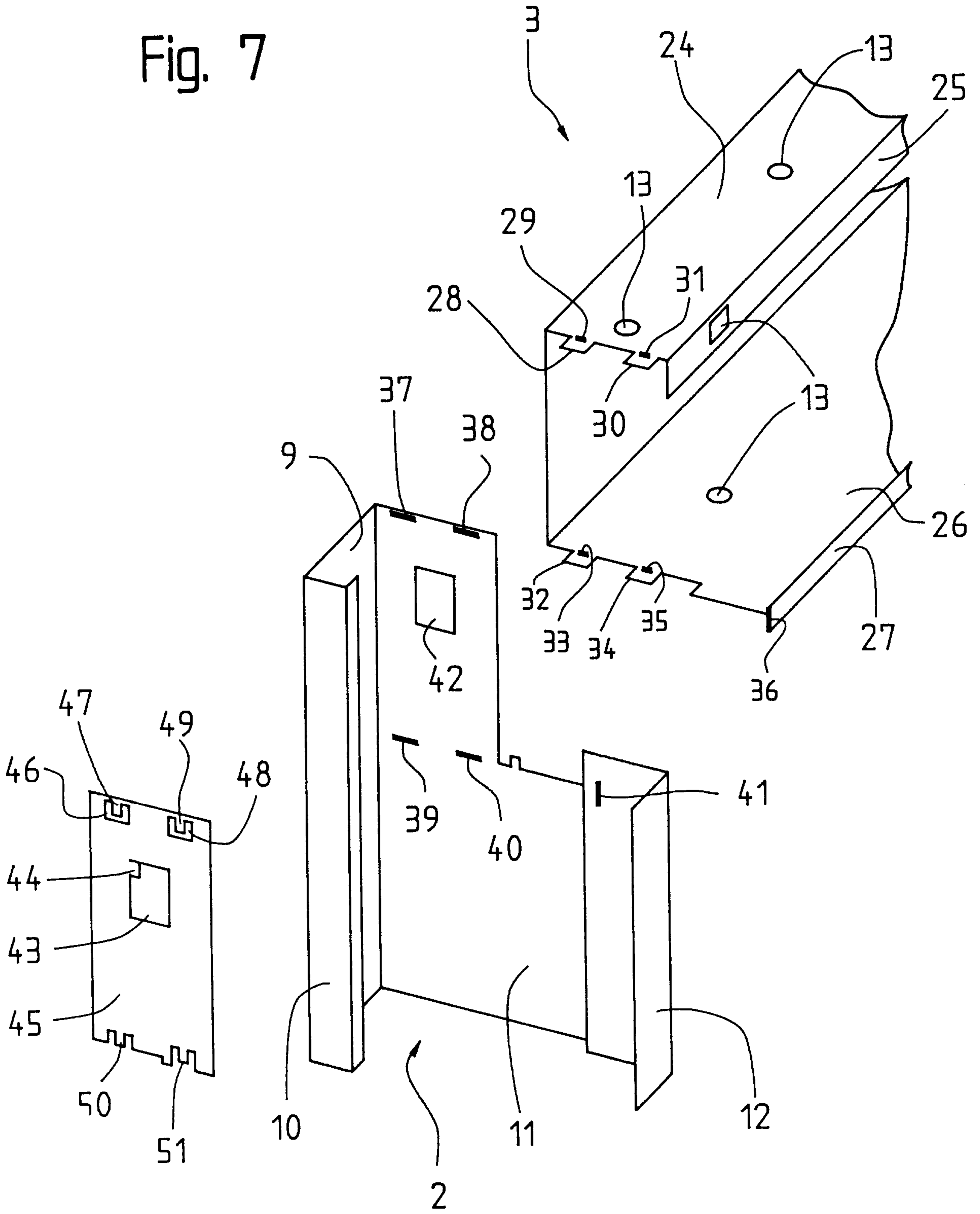

Fig. 10

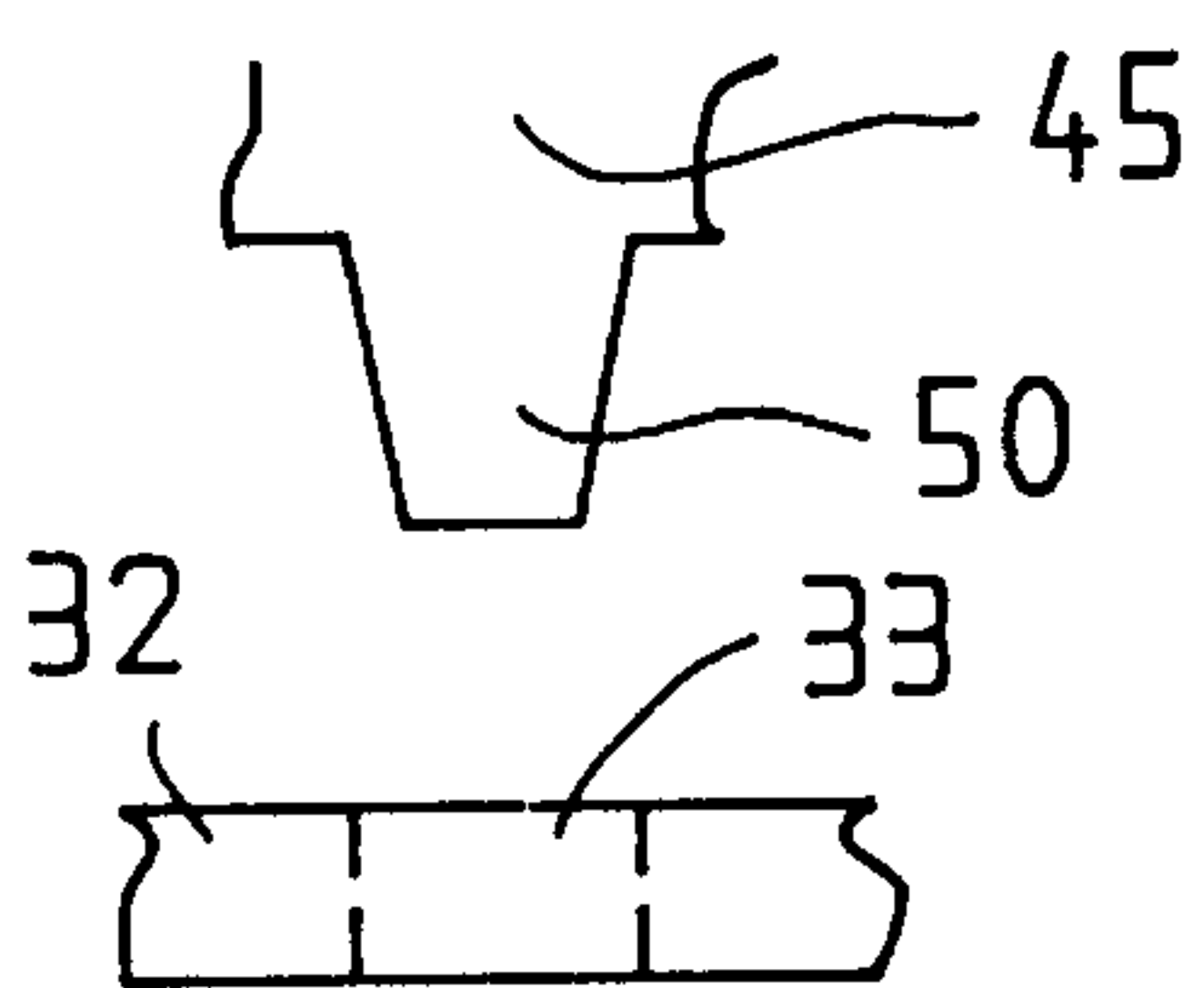

Fig. 11

