

(No Model.)

2 Sheets—Sheet 1.

E. H. DUCHEMIN.  
FARE REGISTER FOR STREET CARS.

No. 523,660.

Patented July 31, 1894.

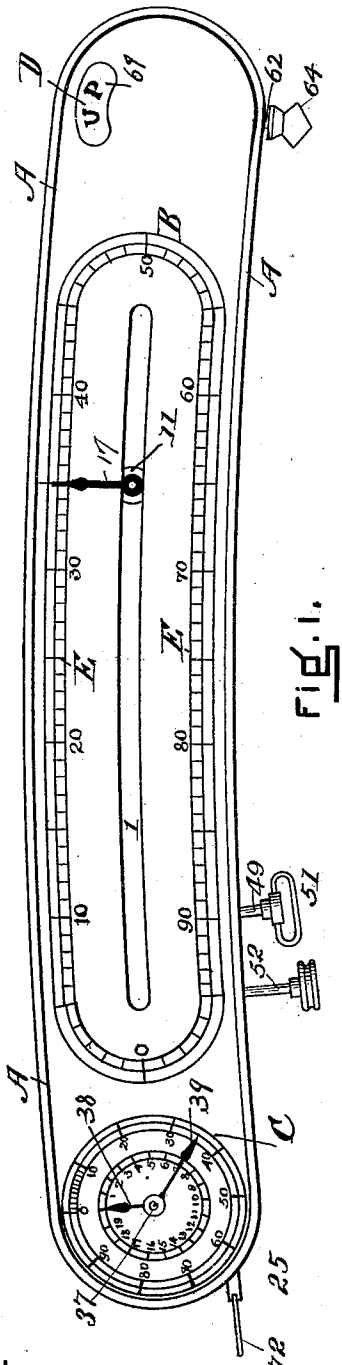

FIG. 1.



FIG. 9.

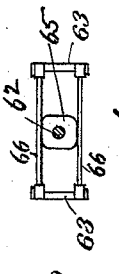

FIG. 10.

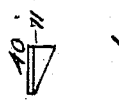

FIG. 11.

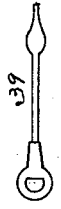

FIG. 12.



FIG. 13.

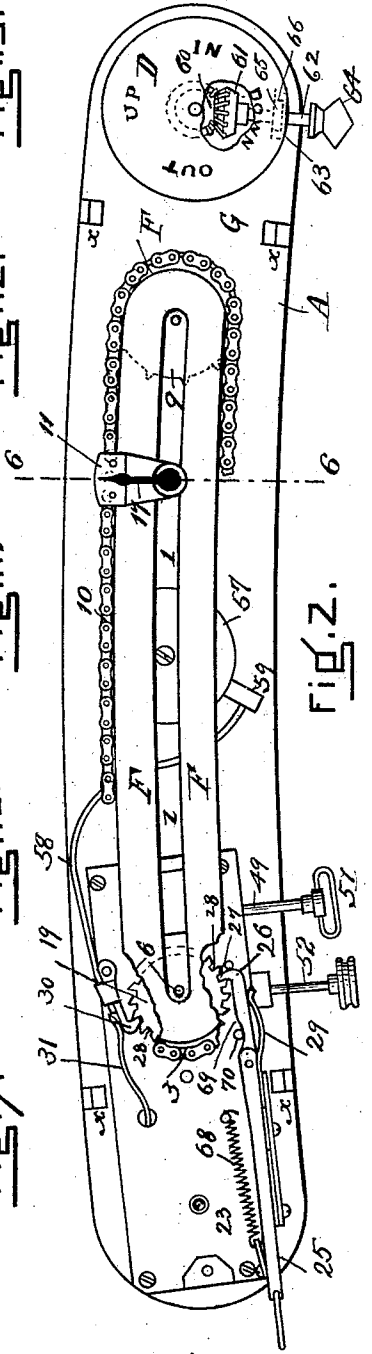

FIG. 2.

WITNESSES  
Frank A. Parker.  
Edward S. Day

INVENTOR  
Edmund A. Duchemin

E. H. DUCHEMIN.  
FARE REGISTER FOR STREET CARS.

No. 523,660.

Patented July 31, 1894.

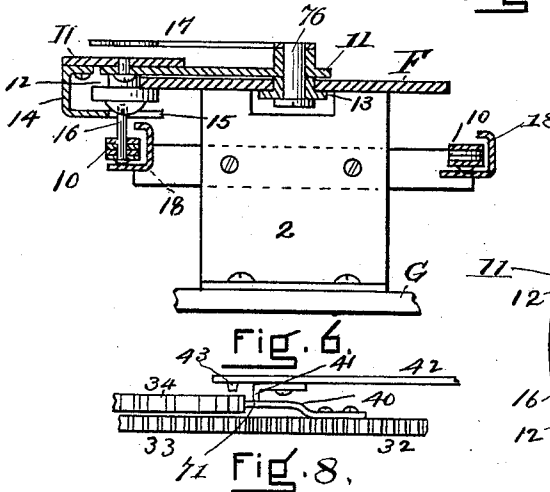
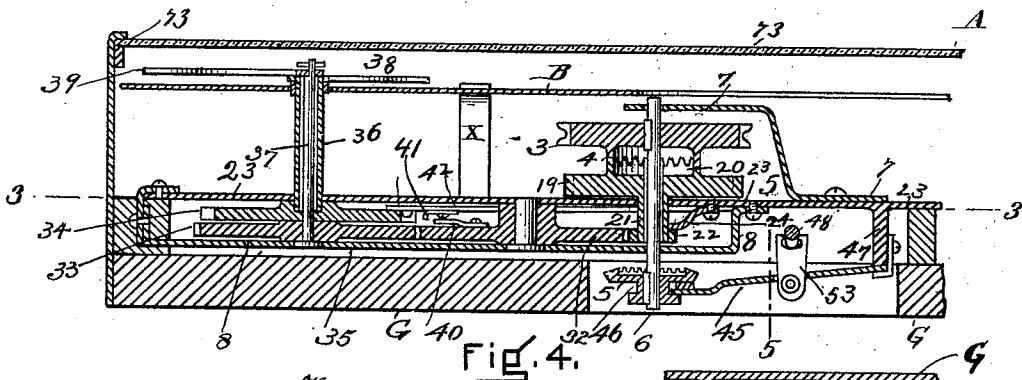
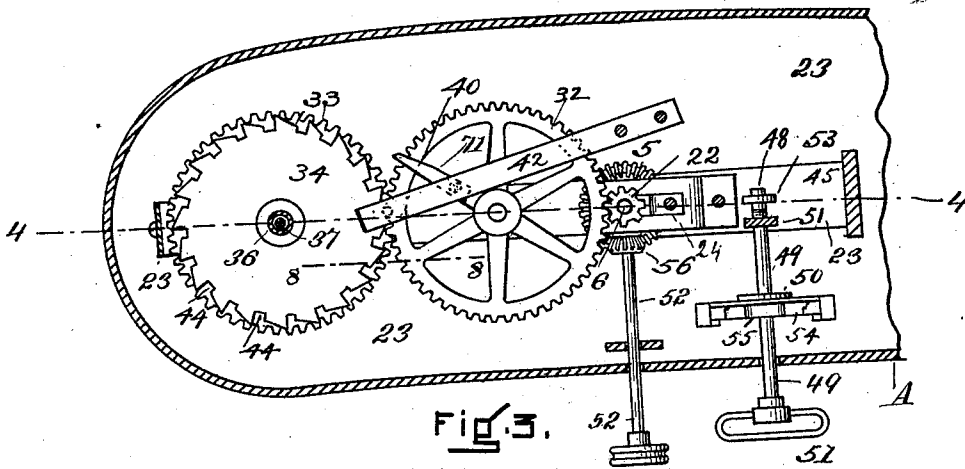

WITNESSES  
 Frank A. Parker  
 Edward S. Day

INVENTOR  
 Edmund H. Duchemin

# UNITED STATES PATENT OFFICE.

EDMUND H. DUCHEMIN, OF NEWBURYPORT, MASSACHUSETTS.

## FARE-REGISTER FOR STREET-CARS.

SPECIFICATION forming part of Letters Patent No. 523,660, dated July 31, 1894.

Application filed May 8, 1893. Serial No. 473,395. (No model.)

*To all whom it may concern.*

Be it known that I, EDMUND H. DUCHEMIN, a subject of Her Britannic Majesty, residing at Newburyport, in the county of Essex and State of Massachusetts, have invented a new and useful Improvement in Fare-Registers for Street-Cars, of which the following, taken in connection with the accompanying drawings, is a specification.

My invention relates to improvements in fare registers of that class that is used in street cars for registering the number of passengers carried during each trip, and also during any given number of trips, and the objects of my improvements are to provide a duplex fare register with a continuous permanent registering mechanism, fitted with a detachable trip registering device, having a central oblong trip dial, and in which the mechanism is so arranged that the trip-hand can be set back or forward at any time during the trip without interfering with the action of the continuous permanent registering device, of which the mechanism is so adapted that the units hand thereof will denote the units in the same ratio as the trip-hand, and that cannot be set backward without destroying the parts of the same; so that should the trip-hand be fraudulently set back, such action would be detected by consulting the circular dial of the continuous permanent registering mechanism; the adaptation of the trip-hand actuating mechanism being of such a nature that the oblong trip-dial thereof may be made on any curved line best suited to the interior outline of the roof of the car; and also to provide an independent rotating trip-indicating disk in the same, that will denote the outward or inward destination of the car. I attain these objects by the mechanism illustrated in the accompanying drawings, in which—

Figure 1 is a plan view of the face of my duplex fare-register, showing the form of the case and the dial-plate thereof, the position of the circular dial-scales of the continuous permanent, and the curved oblong dial-scale of the trip-registering, mechanisms thereon; also the position of trip-indicating disk. Fig. 2 is a plan view of the same, having the dial-plate removed, showing the general arrangement of the trip and trip detaching mechanisms, the guide for the trip-hand carriage,

having a part of the end cut away to show other parts of mechanism, the trip-hand carriage in working position thereon and attached to its actuating chain, the chain in working position, the actuating ratchet-wheel, the pull bar, and the pawl thereof in position to operate the said actuating ratchet-wheel, the position of the shafts of the trip disconnecting and regulating mechanisms, the device for sounding the alarm gong, the gong and gong-hammer, the trip-indicating disk, and its operating mechanism and position in the end of the register-case. Fig. 3 is a section on line 3—3, Fig. 4, showing the arrangement and construction of the principal parts of the continuous permanent registering mechanism, and the device for disconnecting and regulating the trip-registering mechanism. Fig. 4 is a section on line 4—4, Fig. 3, showing the interior construction of the continuous permanent registering and trip-disconnecting mechanisms, and is intended for future reference. Fig. 5 is a section on line 5—5, Fig. 4, and is a detail of the trip-hand disconnecting device. Fig. 6 is a section on line 6—6, Fig. 2, showing the interior construction of the trip-hand carriage and the manner of connecting the same with its actuating-chain, and the position of the rollers on the outer margin of the trip-hand carriage-guide and in the longitudinal slot of the same, and also the position of the trip-hand on its carriage. Fig. 7 is a plan of the same, showing the rear surface of the top end of the said carriage and the position of the angular plate thereon, whereby the carriage is connected to the actuating-chain; also the projecting stud of the said chain in position in the slot of the said angular plate or arm of the carriage. Fig. 8 is a section on line 8—8, Fig. 3, showing in detail the detaining device of the hand that marks the hundreds on the continuous permanent registering dial-scale. Fig. 9 is a plan showing in detail the detaining device of the shaft of the trip-hand disconnecting mechanism. Fig. 10 is a plan showing in detail the detaining device of the shaft of the trip-indicating disk. Fig. 11 is a cross-section of the inclined plane of the radial-bar of the detaining device of the continuous permanent registering mechanism, and is intended for future reference. Figs. 12 and 13, are plans show-

ing the form of the sockets in the hands that denote the units and the hundreds in the dial scales of the continuous permanent registering mechanism, and will be referred to farther on.

Similar letters and figures refer to similar parts throughout the several views.

A, Fig. 1, represents the case of the fare-register, which is a curved oblong in contour, the ends terminating in a semi-circular form; B the dial-plate, having on its left-hand end the circular dial C of the continuous permanent registering mechanism, in its right a curved oblong opening 67 for sighting the rotating trip-indicating disk D, and at the center, between the dial C and the trip-indicating disk D, the curved oblong dial E of the trip-registering mechanism, and a parallel slot 1 in the longitudinal center of the trip-scale E for the passage of the trip-hand, as will be explained farther on.

The dial-plate B is secured in the case A by four uprights  $\alpha$ , (see Fig. 2) which are secured to the bottom G of the case A.

The dial C of the continuous permanent registering mechanism is fitted with two circular scales, the larger of which is divided into one hundred equal parts, which are subdivided and numbered by tens, each divisional point denoting a unit. The smaller circle is divided into twenty equal parts and so numbered, each divisional point denoting a hundred, the full circuit thereof denoting twenty hundreds. The trip-registering scale E, which is a curved oblong in outline, is also divided into one hundred equal parts, which are subdivided into fives and numbered by tens, each divisional point denoting a unit.

The trip-hand carriage-guide F (see Fig. 2) is made of thin flat metal, and is in form a curved oblong, the outer longitudinal margins of which are parallel, and the ends terminate in a semi-circular form, as shown at F, Fig. 2. It is fitted with a central longitudinal slot 1, that reaches to and ends at the axes of the semi-circular outlines of the ends of the dial scale E and is secured in position by two uprights, 2 (Fig. 6), which are secured to the bottom G of the case A. The slot 1 is intended for the passing to and fro of the trip-hand carriage 11, as will be explained farther on herein.

The trip-hand actuating mechanism (see Figs. 2 and 4) is constructed as follows: A resetting bevel gear-wheel 5 of the trip-hand resetting device and a driving chain-wheel 3, fitted with a toothed box coupling 4, are secured on the opposite ends of the shaft 6 thereof, which is provided with suitable bearings in the frame plates 7 and 8, in such position that the shaft 6 is concentric with the semi-circular outline of the left-hand end of the trip-hand carriage-guide F (shown at 6, Fig. 2) and at the opposite end of the said guide F, placed in the same relative position therewith, is a leading chain-wheel 9, which is of the same form and dimensions as the

chain-wheel 3, and rotates on a pivot that is secured to the bottom G of the case A. These two chain-wheels, 3 and 9, are brought into working connection by an endless actuating-chain 10, which passes over and embraces both. In operation, the chain-wheel 3, on the shaft 6, moves the leading chain-wheel 9 and the actuating-chain 10, which by means of a short stud 16 (Fig. 6) projecting therefrom moves the trip-hand around the trip-dial E in a manner that will be explained at the proper time herein.

The trip-hand carriage 11 is made in the form shown at 11 (Fig. 2), and is fitted with three-flanged rollers, 12, 13; the rollers 12 move on the outer margin of the guide F, and the roller 13 in the longitudinal slot 1 therein (shown in Figs. 2, 6, and 7). An angular arm 14 is secured to the rear surface of the trip-hand carriage 11, having in its free end a longitudinally central slot 15, which passes over and embraces the projecting stud 16 of the chain 10 (see Figs. 6 and 7). The pivot on which the roller 13 rotates fits firmly in, and projects through, the face surface of the trip-hand carriage 11 the required distance to secure the trip-hand 17 rigidly thereto, as seen in Fig. 6.

The endless chain 10 is kept in position longitudinally, and is also prevented from sagging, by two rectangular conductors 18, which are secured on the uprights 2 that are secured to the bottom G of the case A (see Fig. 6).

The actuating ratchet-wheel 19 (Fig. 2) of the trip-hand mechanism just described, and also of the continuous permanent registering mechanism, is peculiar in construction, inasmuch as that the heel of each tooth terminates in a rectangular groove 28 and said wheel is provided with a toothed box-coupling 20, the teeth of which are fitted to clutch into the teeth of the box-coupling 4 of the chain-wheel 3 (see Fig. 4), and is rigidly secured to the end of a short hollow shaft or sleeve 21, which is fitted to and rotates on the shaft 6; and on the opposite end of the sleeve 21, the geared driving-spur 22, which actuates the continuous permanent registering mechanism, is rigidly secured (see Fig. 3). The actuating ratchet-wheel 19 and geared spur 22 are kept in position laterally by the surfaces of the frame-plate 23, and an angular arm 24, which is secured to the said frame plate 23. (See Figs. 3, and 4.) The sleeve 21 is made of such proportionate length that when the shaft 6 of the trip-registering mechanism is moved endwise a sufficient distance to unclutch the teeth of the coupling 4 from the coupling 20, the bevel-gear 5 thereon will be brought into working contact with the bevel geared spur 56 of a resetting shaft 51 (see Fig. 3) for a purpose that will be shown in describing the nature and operation of the regulating mechanism.

The operating pull-bar 25 (Fig. 2) is so fitted to the frame-plate 23 that it can be moved back and forth the length of a tooth of the

actuating ratchet-wheel 19. It is furnished at the outer end with a link or ring 72 to which a chain or cord can be attached; and at the inner end, secured thereto by a pivot joint, is a working-pawl 26, the free end of which terminates in a right-angled point 27, which fits into the rectangular groove 28—before described—in the heel of the tooth of the actuating ratchet-wheel 19, and is held therein by a spring 29.

Pivoted to the frame-plate 23, in a position directly opposite to the point 27 of the pawl 26, is a detaining pawl 30, which is held in position against the inclined surface of the tooth of the actuating ratchet-wheel 19 by a strong spring 31. The hammer for sounding the alarm-gong is operated by the free end of this detent-pawl 30, as will be explained in the description of the device.

The operation of the trip-registering mechanism just described is as follows: When the pull-bar 25 is drawn out to the full limit of its reach, the actuating ratchet-wheel 19 is rotated forward the space of one tooth, and as its toothed coupling 20 is clutched into the coupling 4 of the chain-wheel 3, the chain 10 thereon is also moved onward, and by the action of the stud 16 which projects therefrom, in the slot 15 of the angular arm 14 of the trip-hand carriage 11, the carriage 11 and trip-hand 17 are moved longitudinally forward the space of one point on the trip-scale E, and so on. During the passage of the trip-hand 17 from zero around its scale E, when the roller 13 reaches the end of the longitudinal slot 1 of the carriage-guide F, it remains stationary, and becomes, in fact, the axis of the half-circular end of the guide F, around which the outer end of the trip-hand carriage 11 continues to move, drawn by the action of the chain 10, until it has passed the limit of the said half-circle, at which time the roller 13 makes a retrograde longitudinal movement, which continues until it reaches the opposite end of the slot 1, where it remains until the outer end of the trip-hand carriage 11 passes around the opposite end of the guide F, at which time the roller 13 again moves forward toward its normal position (the zero) of the trip-scale of the dial E, the flanges on the rollers 12, 13, keeping the trip-hand carriage 11 in proper position against the face surface of said guide.

The continuous permanent registering mechanism is constructed as follows: The gear-wheels 32, 33 (Figs. 3 and 4) have each an equal number of teeth which gear each into the other, and are provided with bearings in the frame-plates 23 and 35, and are actuated by means of the geared driving-spur 22, that is, on the sleeve 21 of the shaft 6 (shown in Figs. 3 and 4). The ratchet-wheel 34 is fitted with a sleeve 36, which passes over and rotates on the shaft 37 of the geared wheel 33, and both shaft and sleeve project outward from the frame-plate 23 (see Fig. 4), and pass through the center of the dial C of

the permanent registering mechanism the proper distance to secure on the outer end of the sleeve 36 a short hand 38, which reaches to the small circular scale denoting hundreds, and a longer hand 39, on the shaft 37, which reaches to the large circular units scale thereon (as shown in Fig. 1). The wheel 32, which in its connection with the units-hand wheel 33 is simply an intermediate gear-wheel so adapted that the same movement is communicated to the units-hand 39 and trip-hand 17 by the actuating ratchet-wheel 19,—has secured thereto a radial-bar 40 (see Fig. 3), the point of which extends beyond the periphery of said wheel 32 the required distance to come in contact with and rotate the ratchet-wheel 34 one tooth forward. Near the outer end on the front surface of the radial-bar 40 is a transverse inclined plane 71, of the form shown at 71 (Fig. 11) that just before the radial-bar 40 comes in contact with the tooth of the ratchet-wheel 34 acts on a short projecting point 41, which is secured on an elastic-bar 42, and sends the said bar outward from the side surface of the ratchet-wheel 34 (as shown in Fig. 8). This elastic-bar 42 is secured to the frame-plate 23 in such a position that a short detaining stud 43, which is secured in its free end, will pass into and rest in a rectangular groove 44 made in the heel of each tooth of the ratchet-wheel 34 for that purpose thus locking said wheel against either forward or backward movement (see Fig. 3).

In practice, when the gear-wheel 32 has made one rotation, and the units-hand 39, a full circuit of one hundred points on the units-scale,—the end of the radial-bar 40 comes in contact with a tooth of the ratchet-wheel 34, on the sleeve 36 of which the hand that marks the hundreds is secured, and rotates it forward the space of one tooth, and the short hand 38 is advanced one point on the scale denoting hundreds on the continuous permanent registering dial C, the long hand 39 having made the full circuit of the units-scale of the said dial in the same time as the trip-hand 17 has around the trip-scale of the oblong trip-dial E.

It will be noted, that just before the point of the radial-bar 40 comes in contact with the tooth of the ratchet-wheel 34, the transverse inclined plane 71 thereon by the action of the projecting point 41 has sent out the elastic-bar 42 a sufficient distance to withdraw the detaining stud 43 out from the rectangular groove 44 (see 43, Fig. 8), which action releases the ratchet-wheel 34 from the detaining action thereof at such a point of time that the contact of the point of the radial-bar 40 with the tooth of the ratchet-wheel 34 and exit of the detaining stud 43 therefrom is simultaneous; and that just before the contact of the radial-bar 40 and the said tooth is ended, the projecting point 41 of the elastic-bar 42 is released from the action of the transverse inclined plane 71 of the said radial-bar

40, when by the reaction of the elastic-bar 42 the detaining stud 43 is sent in and rests against the side surface of the ratchet-wheel 34, in readiness to spring into its position in the rectangular groove 44 of the tooth thereof when the action of the radial-bar 40 is withdrawn from contact therewith. In this manner the ratchet wheel 34 is continuously subject to the alternate action of the radial-bar 40 and the detaining stud 43 of the elastic-bar 42, and for this reason it would be impossible to move the ratchet-wheel 34 backward without injury to the radial-bar 40 or detaining stud 43; and as the gear-wheels 32, 33, receive their impetus from the geared spur 22, which is actuated by the pull-bar 25, through the medium of the actuating ratchet-wheel 19, it would be impossible to move said wheels backward without injuring the actuating wheel 19 or the right-angled point 27 of the pawl 26 of the pull-bar 25. With these facts in view, it is obvious that the continuous permanent registering mechanism cannot be set back without destroying the parts thereof.

The device for connecting and disconnecting the trip-registering with and from the continuous permanent registering mechanism resetting the trip-hand is constructed as follows: The shaft 6 of the trip-registering mechanism is so fitted in its bearings that it can be moved back and forth endwise by the action of a vibrating arm 45 (see Fig. 4), the free end of which is fitted into a groove 46, that is in the hub of the bevel gear-wheel 5 which is on the said shaft 6. The arm 45 is secured by a right-angular joint to a block 47 that projects out from the frame-plate 23, and is moved by a crank 48. The crank-shaft 49 rotates in bearings 50, (see Fig. 5,) which are secured to the bottom G of the case A. Its outer end is fitted with a cross-handle 51; the inner end terminates in the before-named crank 48 on which is fitted a short pitman 53 that is pivoted in the proper position (about mid-length) in the arm 45; and when the crank-shaft 49 is moved half a turn, the arm 45 is sent out by the action of the pitman 53, and by the next half-turn is brought in, and by these means the shaft 6 is moved back and forth in the manner before named. The crank-shaft is held firmly in position by the action of two parallel spring-bars 54, which are secured in the bearing 50 of the crank-shaft against parallel planes cut in a circular block 55, which is rigidly secured on the crank-shaft 49 (as shown in Figs. 3, 5, and 9).

In practice, when the shaft 6 is sent out, the coupling 4 of the chain-wheel 3 is disengaged from the coupling 20 of the actuating ratchet-wheel 19, which action disconnects the trip-hand mechanism therefrom; and if, while the mechanism is in this position, the pull-bar 25 were drawn out, the continuous permanent registering mechanism only would be moved forward, and during the time that the

mechanism is so placed, the shaft 6 of the trip-hand mechanism and the parts governed thereby can be moved backward or forward without interfering with the continuous permanent registering mechanism. Said shaft 6 being placed under the control of a regulating device in and for the following manner and purpose: The resetting-shaft 51 having on its outer end a thumb-knob is secured in suitable bearing (see Fig. 3) to the frame-plate 23 in such a position that a bevel geared spur 56 which is secured on its inner end will come in working contact with the bevel geared wheel 5 on the shaft 6, when said shaft is sent outward as before described. Thus by the alternate action of the vibrating arm 45 and resetting shaft 51 thereon, the bevel geared-wheel is made to perform the separate function of connecting and disconnecting the trip and continuous permanent registering mechanisms, and actuating the mechanism for resetting the trip-hand.

In practice, when the shaft 6 of the trip-registering mechanism is sent out as hereinbefore stated, the bevel geared wheel 5, which is secured on the inner end thereof, is brought in working contact with the bevel geared spur 56 of the resetting shaft 51 when, by turning said shaft 51 backward or forward, the trip-hand 17 can be placed in any desired position on the trip-scale E, or thus be reset back to zero.

The device for striking the alarm-gong 57 is as follows: The fore end of the wire 58 of the alarm gong-hammer 59 is secured to the free end of the detent-pawl 30 of the actuating ratchet-wheel 19 (see Fig. 2), in such a manner that when said pawl 30 rests against the tooth of the actuating ratchet-wheel, the hammer 59 is as close as may be, without touching, to the alarm-gong 57.

In practice, when the actuating ratchet-wheel 19 is rotated forward the space of a tooth, the free end of the detent-pawl 30 is sent outward by the action of the inclined plane of the passing tooth, and the alarm gong-hammer 59 is sent out from the alarm-gong 57, and when the free end of the pawl 30 has passed the apex of the said passing tooth and is suddenly driven in by the action of the spring 31, the hammer 59 is sent forward, and gives a quick, sharp blow to the alarm-gong 57. It will be noted that the stroke of the hammer on the alarm-gong is simultaneous with the denotation of a point on the scale of the curved oblong dial E by the trip-hand 17.

The trip-indicator consists of a revolving disk D, and is pivoted by means of a short standard to the bottom G of the case A, its axis being at right angles therewith, and is fitted with the bevel gear 60, which is in fact the hub of the disk. The face surface of this disk D is placed at such a distance from the rear surface of the dial-plate B that it can be rotated without touching the same, and is divided into four equal sections, each

section having the word "Up," "Down," "In," "Out," graven thereon, and is moved by a beveled gear 61, that is secured to the hand-shaft 62 and is entirely separate from the registering mechanisms. The shaft 62 rotates in suitable bearings 63, which are secured to the bottom G of the case A (see Fig. 2). Its outer end is furnished with a cross-handle 64, and about mid-length is fitted with a square block 65 (see Fig. 10), which by the action of two parallel spring-bars 66, which are secured in the bearings 63, holds the shaft in the proper position to exhibit singly, at the desired time, any of the words graven on the quarter sections of the disk D. The operation of this device is as follows: The bevel gears 60 and 61 are so connected that when the parallel planes of the block 65 are held between the spring-bars 66, the word "Out" will be in the center of the aperture 67 in the dial B (see Fig. 1). And when in practice the shaft 62 is turned one-fourth of a rotation by means of the handle 64, by the action of the spring-bars 66 on the parallel planes of the block 65 the disk D will be placed and held in the desired position to exhibit singly any of the words graven on its quarter-sections. Thus, if "Down" is to be substituted for "Up," the shaft 62 will be turned in that direction, and when the highest points of the square block 65 has passed the centers of the spring-bars 66, the shaft will be sent into and held in the desired position by the reaction of the said spring-bars, in the manner shown in Fig. 10.

It will be noted that the action of the crank-shaft 49 of the connecting and disconnecting mechanism is governed in the same manner by the parallel spring-bars 54, except that the block 55 is circular, and has two parallel planes cut thereon, which gives the same an oblong outline (as shown at 55, Fig. 9), and the shaft is placed and held in position at every half rotation thereof in this manner: when it is necessary to connect or disconnect the trip-registering mechanism, the crank-shaft 49 thereof may be turned to the right or left, and, when the highest points of the block have passed the centers of the spring-bars, as already described, the block 55 is sent into and held in position by the spring-bars 54. The difference in the action of the square block 65 and oblong block 55 being that the square block is sent in and held in position at every quarter-turn, and the oblong at every half-turn, of their respective shafts.

The operation of the combined trip and continuous permanent registering mechanisms is as follows: When by the action of the pull-bar 25 the actuating ratchet-wheel 19 is rotated forward, the space of one tooth, the trip-hand 17 and the units-hand 39 of the continuous permanent register are brought forward one point on their respective dial scales, and the gong receives a blow simultaneously, and so on, until the said hands 17 and 39 have registered one hundred, at which time the outer end of the radial-bar 40 comes in con-

tact with a tooth of the ratchet wheel 34, and rotates the said wheel forward the space of one tooth and the short hand 38 is advanced one point on the scale representing hundreds on the dial C, and so continuously with the continuous permanent registering device, irrespective of the number of trips. The trip-hand mechanism, however, can be detached therefrom and the trip hand be reset at the zero of its dial-scale at any required time in the manner before explained. When the pull-bar 25 has been drawn out in the manner and for the purpose before explained, it is brought back by the action of a suitable spring 68 (see Fig. 2).

In practice: At the commencement of the trip, the indicating-disk D is placed in the position to exhibit the word "Out," and the trip-hand 17 and the continuous permanent registering hands 38, 39, are set at the zero of their respective dial-scales; and at the end of the trip, should the trip-hand point to sixty on the trip-scale E, so also will the units-hand 39 point to sixty on the unit-scale C, and will so remain after the trip-hand has been reset at "zero" on the trip-scale E at the commencement of the next trip; and, at the finish of which should the trip-hand again point to sixty, the continuous permanent registering hands, 38, 39, would point to one hundred and twenty, in this manner: the short hand 38, that denotes the hundreds, would point to one, and the units-hand 39 would point to twenty, and so on. Thus by noting the position of the continuous permanent registering hands at the start and finish of each trip, the exact number of passengers carried during the same can be easily found without reference to the trip-hand, the units-hand 39 being in this respect a tell-tale device of the movement thereof.

The peculiar features of the trip-registering mechanism herein described, and of the parts composing the same, are in the curved oblong form and position of the trip-dial and dial-scale E (as shown in Fig. 1), and the manner and means of leading the trip-hand around the said scale, the leading medium therefor (the actuating-chain 10) being of such a pliable nature that the fare-register can be made on a straight or curved line of any desired proportion to suit the interior outline of the roof of the car in which it is to be used, by simply changing the curve of the chain-conductors 18 to correspond with the curve of the guide F of the trip-hand carriage 16, and in the peculiar form of the teeth of the actuating ratchet-wheel 19, inasmuch as there is a rectangular groove 28 at the heel of each tooth for the reception of the right-angular point 27 of the pawl 26, which is pivoted to, and forms a part of, the pull-bar 25, and is fitted with a cam surface 69 (see Fig. 2), which by the action of a pin 70 thereon, during the outward movement of the pull-bar 25, lifts the point 27 out of the rectangular groove 28 a sufficient distance to prevent it from interfering with

the radial wall of the said rectangular groove during the return of the said pull-bar 25. The connecting and disconnecting device is also peculiar, inasmuch as that the trip-registering mechanism can be detached from the permanent registering mechanism, and again united by rotating the crank-shaft 49 a half a rotation back and forth (in the manner described); and so also is the means of resetting the trip-hand 17 at the commencement of each trip.

The advantages derived by the use of these improvements are that, by reason of its improved oblong form, the fare-register can be placed in all styles of cars, which cannot be successfully done at present for the want of the required space in which to place them; and, for the same reason (conformity to the various outlines, as explained) it can be placed in such a position as will preclude all danger of the accidental operation thereof.

The advantage derived from the improvements in the teeth of the actuating ratchet-wheel is that the point 27 of the pawl 26 of the pull-bar 25 is thereby made a positive detaining stop that holds the actuating ratchet-wheel in such a manner that it is impossible to move it backward without injuring or destroying the pawl 26 or actuating ratchet-wheel 19, or forward except by the action of the pull-bar 25; and as the cam-shaped surface 69 of the pawl 26 is so formed that should the pull-bar 25 be accidentally drawn out any distance less than the full reach thereof, the point 27 of the pawl 26 would not be lifted entirely out of the rectangular groove 28 of the actuating ratchet-wheel 19, which on the return of the pull-bar 25 would be moved back to its primary position, which action prevents the danger of the pawl 26 passing prematurely over the apex of the succeeding tooth, thus insuring a correct denotation. The improvements in the connecting, disconnecting, and resetting the trip-registering mechanism are originality of construction, simplicity in operating, and absolute certainty of action.

The form of the teeth of the ratchet-wheel 34 that moves the short hand 38 which denotes the hundreds on the scale of the dial C of the continuous permanent registering mechanism is, as before stated, similar in form to the teeth of the actuating ratchet-wheel 19 of the trip-registering device, and is also held firmly in position by a stop or detaining stud 43, but not in the same manner, inasmuch as that the stop enters and makes its exit in and from the rectangular groove at the heel of the tooth by a lateral movement, as before explained; and as the elastic-bar to which the stop or detaining stud 43 is fitted is elastic in a lateral direction only, that is, at right-angles with the path of action of the ratchet-wheel 34 and unyielding in the line of said path and is rigidly secured to the frame of the machine, it follows that the wheel is held immovable in that direction

thereby, and is entirely independent of the action of the geared wheels 32, 33, at all times, except when it is moved by the action of the radial bar 40 in the manner hereinbefore described, the geared-wheels 32, 33, being held firmly in position at all times by the point 27 of the pawl 26 of the pull-bar 25, and in this manner the continuous permanent registering mechanism is held directly subject to the action of the pull-bar 25, and it is for this reason that in this peculiar action the special value of the right-angled point 27 of the pawl 26 and rectangular groove 28 exists.

It will be noted that each of my registering devices is in itself a perfect practical combination that can be operated separate from the other by means of the actuating-wheel 19 and pull-bar 25, and further, be supplied with an alarm-gong thereby, in which event the trip-hand mechanism would simply denote the number of persons carried during each trip; that, when both devices are combined and operated in one machine, the units-hand of the continuous permanent register and the trip-hand denote equal unit points on their respective dial-scales simultaneously; that, by reason of the peculiar construction and arrangements of the respective parts that constitute the continuous permanent register as before described, it is impossible to move the operating mechanism thereof in any direction at any time except in a legitimate manner without injuring the same, as before explained; and that, by reason of the peculiar form of the sockets in the hands 38, 39, of the permanent registering device (shown in Figs. 12, 13), it would be impossible to rotate the same back or forward on the sleeve 38 and shaft 37 respectively without destroying the same or injuring the parts on which they are secured. In view of these facts, it is obvious that by noting the position of the hands of the register at the time and in the manner hereinbefore explained, any inaccuracy in the registration of the persons carried each trip would be detected at the finish of the same.

The practical benefits accruing from the use of the devices hereinbefore named are, that it is impossible to show or make a false registry of fewer persons than have been carried during the trip, without immediate detection, or of the total number carried for any given number of trips, by simply noting the number of times that the hands 38, 39, point simultaneously to the "zero" of their respective scales on the dial C, as such pointing denotes twenty hundred; that by reason of the oblong form of the duplex-register case A and the flexibility of the actuating-chain 10 of the trip-hand, the duplex-register can be fitted to and placed in the car in such a position (against the interior surface of the roof) as will economize the space occupied thereby, and insure more security from accidents thereto; and that, owing to the great length of the trip-scale E, the unit points on

the same are placed so far apart that the movement of the trip-hand in denoting the same can be plainly seen from the most remote part of the car, thus obviating the necessity of using a large units trip-dial scale disk.

To protect the dial plate and prevent the parts from unnecessary handling, the case A is provided with a glass face plate 73, which is permanently secured therein, as shown in Fig. 4.

I am aware that fare registers are old, and therefore do not claim the same broadly, but simply as an improved machine adapted as herein described for the purpose named: the gist of my invention residing in the construction of a positively continuous permanent register mechanism; that is, of such a character that the hands thereof cannot be set back, but are held rigidly where placed by the action of absolutely unyielding stops; that are not dependent on frictional, re-actionary, or any other uncertain influence for their efficiency, nor forward except in a legitimate manner, and that, barring accidents, must, when propelled, advance on continuously as long as the parts thereof hold out; in the manner of striking the alarm-gong; and in the adaptation of the mechanism to and for the reception of the trip registering mechanism.

In the construction, general arrangement, and form of the parts of my trip-registering mechanism, especially in the curved oblong form of the case A, dial plate B, carriage-guide F, and trip dial-scale E, and the means for and manner of leading the trip-hand around the same, and of detaching and connecting the trip, from the continuous permanent mechanism, and in the construction and form of the trip indicating-disk and the position of the same in the extreme end of the case A; and in the construction and adaptation of the actuating ratchet-wheel 19 whereby the units-registering hands of both mechanisms denote the same simultaneously on their respective dial-scales, so that should the trip-hand be moved back or forward, by accident or otherwise, during the trip, the same can be detected and the error corrected in the manner hereinbefore described, and it is because of this repeating or tell-tale action of the unit registering-hands that I have named my invention a duplex fare register.

Having thus described my invention, what I claim as new, and desire to secure by Letters Patent, is—

1. The herein described duplex fare-register for street cars, consisting principally in the combination of a curved oblong case, a curved oblong dial plate therefor, having the circular dial-scales of the continuous permanent registering mechanism on one end, a curved oblong slot for sighting the trip-indicating disk in the opposite end, the curved oblong dial-scale of the detachable trip registering mechanism in the center, between the circular dial-scales and the curved oblong

sighting slot; a slot in its longitudinal center, for the passage of the detachable trip-registering hand therein, a continuous permanent registering mechanism of the character herein described, the axes of the registering hands thereof being the common center of the circular dial-scales, and a detachable trip registering mechanism in working connection therewith, having a curved oblong trip dial-scale; herein described means for advancing the trip-registering hand longitudinally and concentrically around the same; also the herein described means for detaching and connecting the same from and with the continuous permanent registering mechanism; a trip indicating mechanism, the axis of the disk thereof being concentric with the semi-circular end of the case A, constructed and arranged substantially as herein shown and described.

2. In a duplex fare-register of the character herein described, in the continuous permanent registering mechanism thereof, the combination of an actuating ratchet-wheel, rotating the shaft of the detachable trip-registering mechanism, a driving geared spur secured thereon, an intermediate gear wheel driven thereby, and driving a units-hand geared wheel, a units-hand permanently secured on the shaft of the same, a ratchet-wheel revolving on the shaft of the units-hand geared wheel, a hand denoting hundreds secured permanently thereto, a radial bar secured on the intermediate geared wheel whereby the ratchet-wheel is rotated, the incline plane thereon, an elastic-bar secured on the frame of the mechanism, a projecting point, and detaining stud carried on its free end, whereby the ratchet-wheel is alternately held rigid, as herein described, a detent pawl, the fore end of the gong-hammer wire secured to the free end thereof, a gong, the circular dial-scales, a toothed box coupling carried by the actuating ratchet-wheel, whereby the trip-registering mechanism is actuated, and a working pawl, the cam-shaped surface thereon actuated by stationary pin, the right-angled point thereof, in working contact with the rectangular groove that is in the heel of each tooth of the actuating ratchet-wheel, and having a pull-bar or other suitable propelling device pivoted to its rear end, constructed and arranged substantially as herein shown and described.

3. In a duplex fare-register of the character herein described, in the registering mechanism thereof, a detachable trip-registering mechanism, consisting in the combination of a curved oblong trip-registering scale, a curved oblong guide for the trip-hand carriage, the central longitudinal slot therein for the passage of the trip-hand, a rotating shaft movable endwise, a driving chain-wheel secured thereon, a toothed box coupling carried thereby; clutched into a toothed box coupling carried by the actuating ratchet-

wheel of the continuous permanent registering mechanism, a resetting bevel-gear of the trip-hand resetting mechanism secured on the said shaft, engaging with a geared-spur carried by a resetting-shaft of the said mechanism, the means herein described for advancing the trip-hand longitudinally and concentrically around the curved oblong trip-registering scale, the herein described means for detaching and connecting the actuating mechanism of the trip-hand from and with the continuous permanent registering mechanism, and the toothed box coupling carried by the actuating ratchet-wheel thereof, whereby the trip registering mechanism is actuated, constructed and arranged substantially as herein shown and described.

4. In a duplex fare-register of the character herein described, in the connecting, disconnecting, and trip-hand resetting mechanism thereof, the combination of a crank-shaft secured in suitable bearings to the bottom of the case A, an oblong block, controlled by parallel spring-bars fitted in the said bearings secured thereon, a crank secured on the end thereof, a vibrating arm connected therewith by means of a pitman, the said vibrating arm, secured by a right-angular joint to the frame of the case A, the free end thereof embracing the hub of the bevel geared-wheel of the trip-hand resetting mechanism, and the said bevel geared-wheel embraced and moved by the said vibrating arm, a resetting shaft secured in suitable bearings to the said frame, a bevel geared-spur secured on the end thereof and engaging with the said bevel geared-wheel of the trip-hand mechanism, at the times and in the manner substantially as herein described.

5. In a duplex fare-register of the character herein described, in the trip-indicating mechanism thereof, the combination of a rotating disk pivoted to the bottom of the case A in such a position that its axis is concentric with the semicircular ends of the same, a bevel-gear secured on the hub thereof, and a hand-shaft secured in bearings to the side of the case A, a square block, controlled by parallel spring bars fitted in the said bearings, secured thereon, a geared-spur on the extreme end thereof, engaging with the bevel-gear secured on the hub of the disk whereby it is rotated, constructed and arranged substantially as herein shown and described.

6. In a duplex fare-register of the character herein described, in the continuous permanent registering mechanism thereof, the combination of an intermediate geared-wheel of the said mechanism carrying a radial-bar having a transverse inclined plane on its outer end, an elastic bar permanently secured to the frame of the mechanism and fitted with a projecting point and a detaining stud on the free end thereof, and the hundreds-hand ratchet-wheel fitted with a rectangular groove at the heel of each tooth and controlled by the alternate action of the said radial-bar,

and detaining stud, at the times and in the manner substantially as herein described.

7. In a duplex fare-register of the character herein described, in the trip-hand mechanism thereof, the combination of a trip-hand carriage, a trip-hand permanently secured thereto, the flanged rollers thereon, moving on the outer margin of a curved oblong carriage-guide, and in the central longitudinal slot in said carriage-guide, an angular arm secured on the said trip-hand carriage, the central slot in the said angular arm, embracing a projecting stud of an endless actuating chain, and a curved oblong carriage-guide, the longitudinally central slot therein, an endless actuating chain, embracing a driving chain-wheel and a leading chain-wheel, conductors therefor, a stud projecting from the said actuating chain, engaged in and embraced by the central slot in the angular arm of the said trip-hand carriage, a leading chain-wheel, a driving chain-wheel, connected with the means substantially as described for moving the said endless actuating chain, whereby the trip-hand carriage is moved longitudinally and concentrically around the curved oblong trip dial-scale, constructed and arranged substantially as set forth.

8. In a duplex fare-register of the character herein described, in the continuous permanent and trip-registering mechanism thereof, the combination of the shaft of the trip registering mechanism, the resetting bevel gear-wheel, the driving chain-wheel having a toothed box-coupling secured on the ends of the same, and the toothed box-coupling of the actuating ratchet-wheel of the continuous permanent registering mechanism engaged with the toothed box-coupling on the driving chain wheel, substantially as herein shown and described.

9. In a duplex fare-register of the character herein described, in the trip-hand mechanism thereof, the combination of a curved oblong trip-dial, a curved oblong trip-dial scale as herein described, and, a trip-registering hand fitted—when placed in connection with the herein described means therefor—to move longitudinally and concentrically around the said curved oblong dial-scale in the time and manner substantially as herein described and set forth.

10. In a duplex fare register of the character herein described, in the continuous permanent and trip-registering mechanism thereof, the combination of the intermediate gear-wheel, radial-bar carried thereby, units-hand gear wheel, units-hand, ratchet-wheel carrying the hundreds-hand, elastic-bar, projecting point, detaining stud carried thereby, circular dial-scales, driving and leading chain-wheels, toothed box-coupling carried by the driving chain-wheel, the endless actuating-chain, conductors therefor, curved oblong guide for the trip-hand carriage, trip-hand carriage, trip-hand, curved oblong trip dial-scale, and the actuating ratchet-wheel, the toothed box-coupling

ling carried thereby, engaged with the toothed  
box coupling on the driving chain-wheel,  
whereby the detachable trip-registering mech-  
anism is actuated, the driving spur thereon,  
5 whereby the continuous permanent register-  
ing mechanism is actuated in such a man-  
ner that the units-hand thereof moves in  
unison with the trip-hand and detects any  
false movement made thereby, the working  
10 pawl, the pull bar, whereby the actuating

wheel is rotated, constructed and arranged  
substantially as herein shown and described.

In testimony whereof I have signed my  
name to this specification, in the presence of  
two subscribing witnesses, on this 1st day of 15  
May, A. D. 1893.

EDMUND H. DUCHEMIN.

Witnesses:

FRANK G. PARKER,  
WILLIAM DUCHEMIN.