

W. E. WILLIAMS.  
 AUTOMATIC POSTER DISPLAY MACHINE.  
 APPLICATION FILED FEB. 21, 1910.

994,811.

Patented June 13, 1911.

3 SHEETS—SHEET 1.

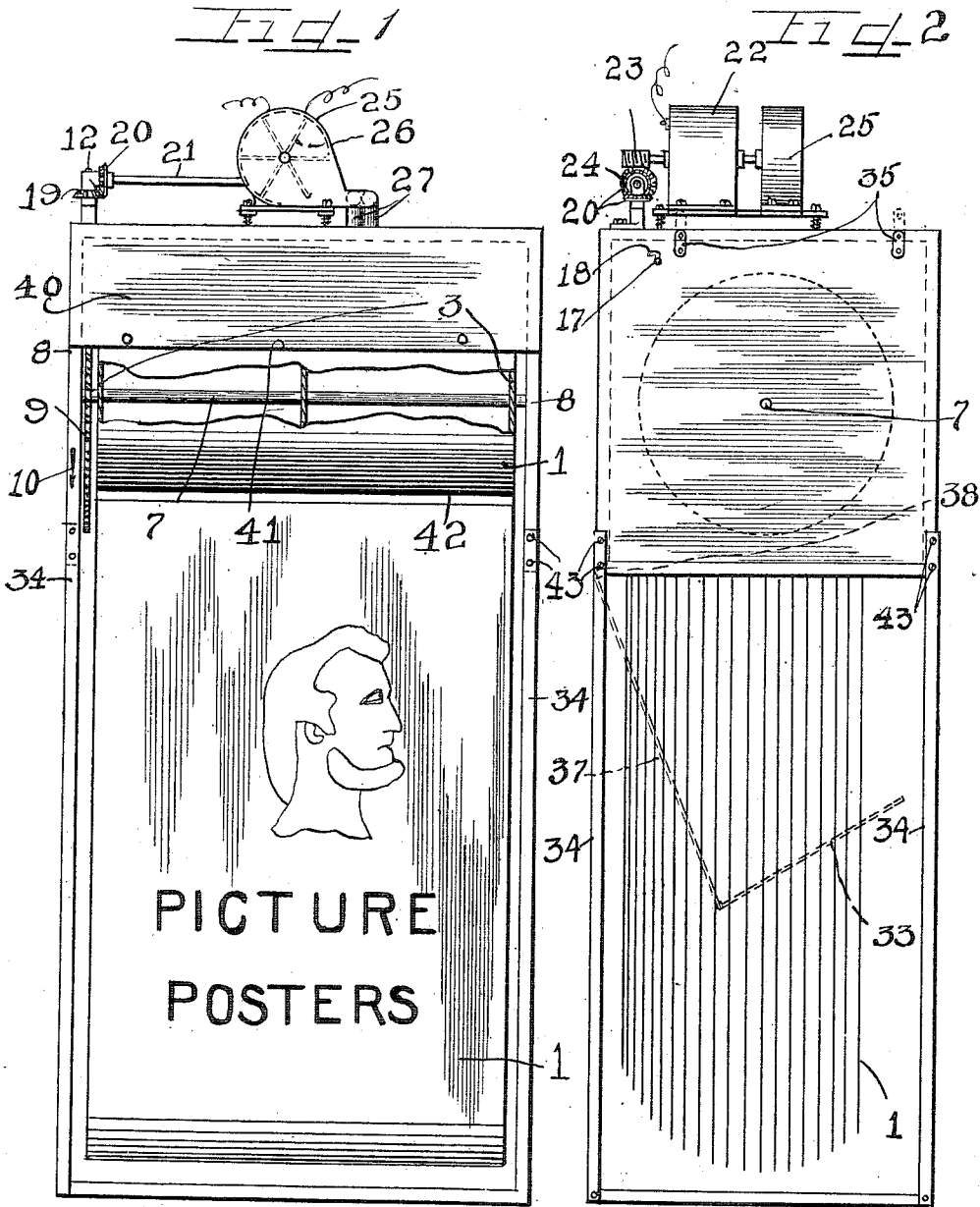

WITNESSES

J. St. Angell.  
 R. Craig Green

INVENTOR

W. E. Williams  
 Wallace Green, Atty

W. E. WILLIAMS.  
 AUTOMATIC POSTER DISPLAY MACHINE.  
 APPLICATION FILED FEB. 21, 1910.

994,811.

Patented June 13, 1911.

3 SHEETS-SHEET 2.

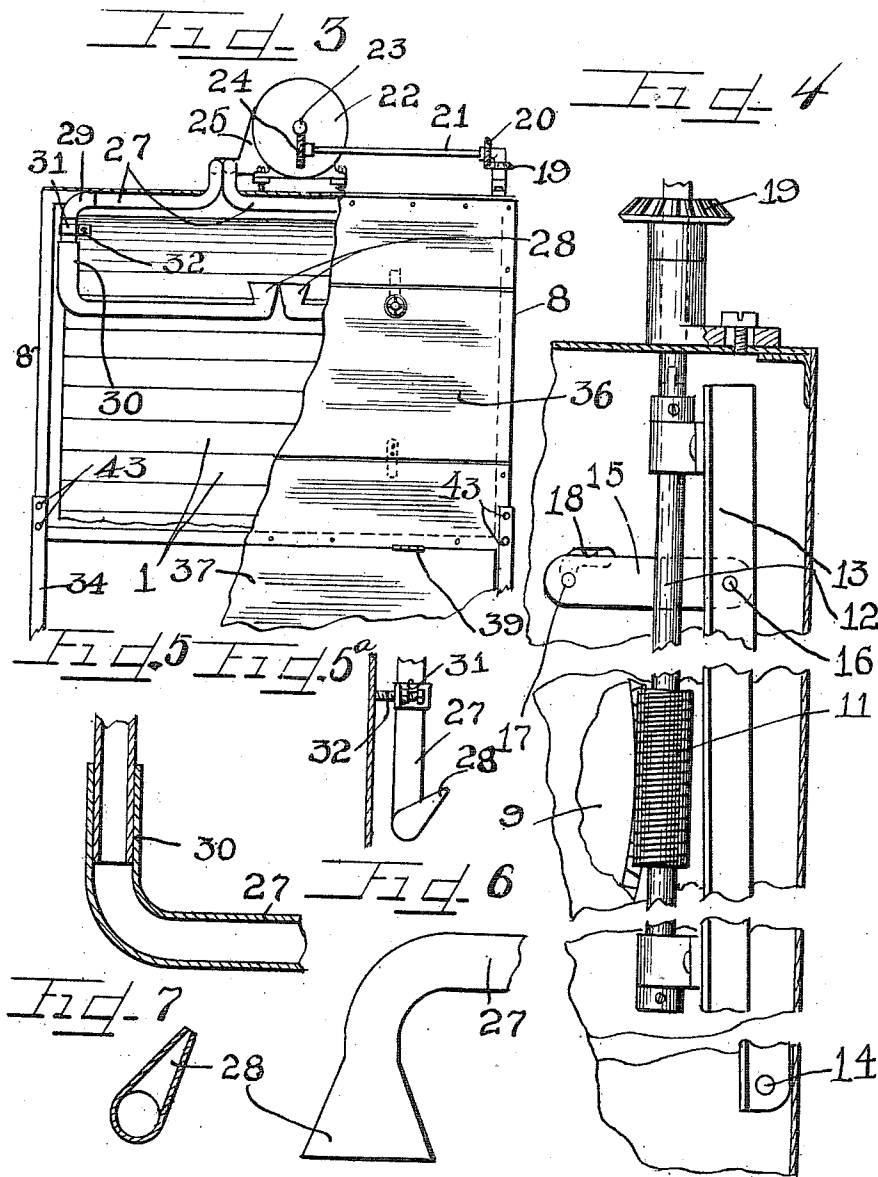

WITNESSES  
 J. St. Angell  
 R. Craig Greene

INVENTOR  
 W. E. Williams  
 Wallace Brown, Atty.

W. E. WILLIAMS.  
 AUTOMATIC POSTER DISPLAY MACHINE.  
 APPLICATION FILED FEB. 21, 1910.

994,811.

Patented June 13, 1911.

3 SHEETS—SHEET 3.

Fig. 8

Fig. 9

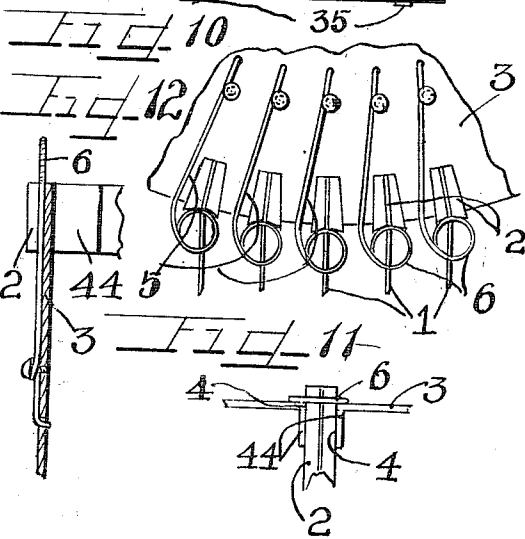
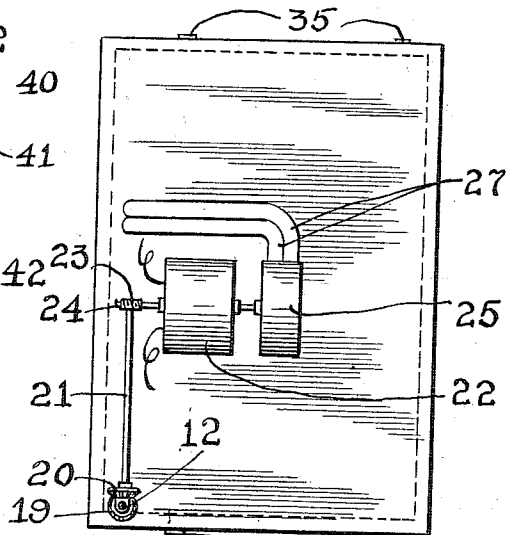
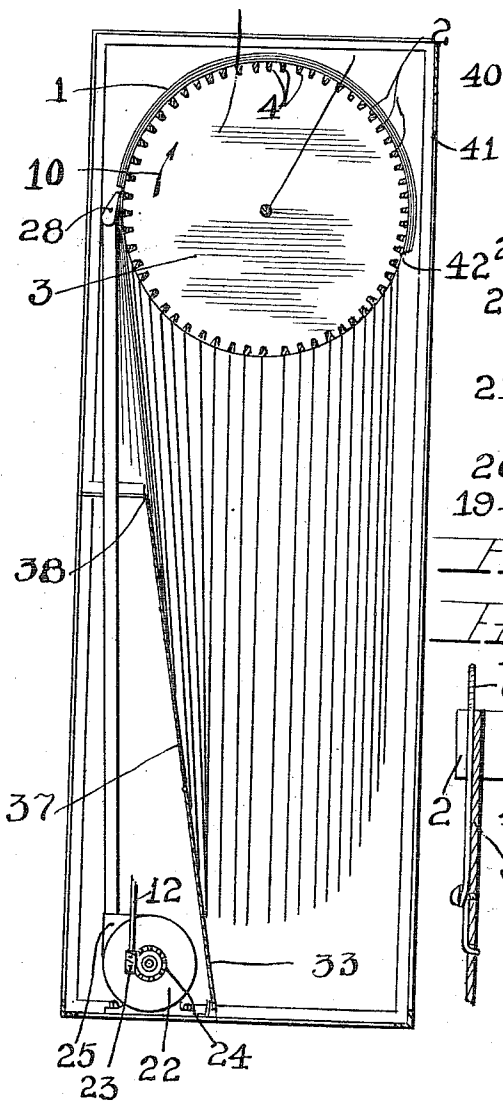

WITNESSES  
*J. H. Angell*  
*R. Craig Greene*

INVENTOR  
*W. E. Williams*  
 by *Wallace Greene*, Atty.

# UNITED STATES PATENT OFFICE.

WILLIAM ERASTUS WILLIAMS, OF CHICAGO, ILLINOIS.

AUTOMATIC POSTER-DISPLAY MACHINE.

994,811.

Specification of Letters Patent. Patented June 13, 1911.

Application filed February 21, 1910. Serial No. 545,076.

*To all whom it may concern:*

Be it known that I, WILLIAM ERASTUS WILLIAMS, a citizen of the United States, residing at Chicago, in the county of Cook and State of Illinois, have invented a new and useful Improvement in Automatic Poster-Display Machines, of which the following is a specification.

My invention relates to that class of machines in which a series of flexible sheets have one margin attached to a drum or reel and are all wound about the latter, their free portions falling in succession, by gravity, as the drum rotates, thereby exposing in succession the faces of all the sheets, which may be sheets forming merchandise, or samples of merchandise, or may bear advertising or amusement matter.

The general object of the invention is to produce an unusually compact, simple, and inexpensive machine of this class and one capable of handling safely, whenever desired, large sheets of wholly unprepared, cheap poster paper, and this object is attained by devices illustrated in the accompanying drawings, in which,—

Figure 1 is a front elevation of the machine with a poster exposed. Fig. 2 is a right end elevation. Fig. 3 is a rear elevation of the parts of the machine. Fig. 4 is an enlarged detail of the driving mechanism. Figs. 5, 5<sup>a</sup>, 6 and 7 are wind pipe details. Fig. 8 is a cross-sectional elevation showing a modification in the location of the motor. Fig. 9 is a top plan. Fig. 10 is a detail showing the arrangement of the fastening of the posters in the machine. Fig. 11 is a detail of a front view of parts shown in Fig. 10. Fig. 12 is a detail side view of parts shown in Fig. 10.

The machine involves the use of a reel adapted to hold corresponding margins of many sheets parallel to the reel's axis, a motor to rotate the reel and wind the free bodies of the several sheets about the same, and means for assisting gravity in unwinding the sheets successively when, in the rotation of the drum, each reaches a predetermined point.

In the figures, 1 represents flexible sheets each having one margin secured to a reel consisting of disks 3 fixed upon a shaft 7 rotatably mounted in a casing frame 8 which is provided with lugs or ears 35 by which it may be suspended upon a wall or

from a wall, and also with a detachable lower frame or legs 34, secured to the frame or casing above by screws 43 or the like, whereby the machine may stand upon any suitable support instead of being suspended, should that be desired. The casing is normally closed above, at each end, and in the rear but open below, and in front except for a small section 40 at the upper side, and when the sheets are all wound and the apparatus is to be protected or transported, a bottom 37 and a part 33, both hinged together and hinged to the rear of the casing at 39, Fig. 3, or near the rear of the casing, at 38, Fig. 8, are swung upward to close the lower side and the remainder of the front side, the section 33 in this case being secured to the section 40 by screws or the like. The casing is also, for convenience, provided with a door 36 in its rear wall.

The reel disks are provided with equally spaced, wedge-like, radial, peripheral notches, 4, each to receive a pair of equal slats 2, of correspondingly wedge-like cross section, between which is held, by paste or otherwise, the margin of one of the sheets 1, the width of which is a little less than the length of the slats. The pairs of slats fit in the notches in the disks and are held in place at each end by springs 5 fixed to the disks and each having a free terminal loop 6 adapted to be sprung over the corresponding ends of a pair of slats and hold them in their notch as seen in Fig. 10. The sheets are thus held with security although any one may be easily and quickly withdrawn without disturbing the others. The disks have flanges 44 alongside their notches so that a broad bearing for the slats may be had although the disks are very thin and light, which is very desirable.

The reel is rotated in the direction of the arrow 10, winding all the sheets one upon the other, around the reel, by means of a worm gear 9, worm 11, shaft 12, gears 19, 20, shaft 21, worm wheel 24, and an electric motor 22, shown in the primary form as mounted upon the top of the casing. The shaft 12 is mounted in bearings on an arm 13 pivoted at 14 to the frame and held in position by a link 15 pivoted to the arm at 16 and provided with a screw stud 17 projecting through the casing in a slot 18 which allows the link to be raised and pushed over to swing the worm out of engagement with

its wheel, when it is desired to detach the reel from the motor quickly, leaving it free to be rotated for reaching any desired sheet. The motor shaft also drives a fan 26 in a casing 25 and thus forces air through pipes 27, along the walls of the casing, to the rear of the reel where it is upwardly and inwardly discharged through nozzles 28, the delivered air instantly passing under the margin of each sheet, when, in the rotation of the reel, that margin passes above the point of delivery, raising the sheet from its companions and gently urging it around the reel. The sheet is thus freed from frictional engagement and gravity unwinds it and it falls to pendant position much sooner than it otherwise would, or in other words each sheet may be wound about an unusually large part of the reel and still fall with entire certainty at the proper time. It follows that for a sheet of given size the reel may be unusually small and thus the machine will occupy less space than would ordinarily be required, which is of great practical importance.

The pipes are provided with adjustable joints at 29 and are held by clips 31 and adjusting rods 32 resting against the casing. By this means the nozzles may be adjusted so near the reel as to serve as detents for the free ends of the sheets; but it is obvious that this is only a convenient detent mechanism, rather than an invariable one. The nozzles are also vertically adjustable, the joints 30 (Fig. 5) being telescopic, so that the point in the reels revolution at which the sheets are freed and lifted may be varied.

The motor and fan may be placed at the bottom of the machine, as shown in Fig. 8, the shafts and pipes being rearranged in an obvious way.

A portion of the back of each sheet is exposed between 41 and 42, Figs. 1 and 8, and this portion may bear a picture, advertising matter or the like, so that practically the entire front is utilized.

It is obvious that the use of means other than an air blast for aiding gravity, and securing early dropping of the sheet with the possibility of a smaller drum, is within my invention; and it is also clear that the apparatus may be used, without inventive changes for the display of pictures, wall paper, maps, samples of textile or other suitable goods, rugs, and other merchandise; and further that the reel may be replaced by any other suitable form of carrier for the sheets.

60 What I claim is—

1. In a machine of the class described, a reel or drum and means for fastening to it the ends of the poster sheets, means for revolving the drum slowly and means for discharging a current of air at the ends of

the sheets as they are wound upon the drum to lift the sheet from the body of the drum and assist in its discharge or unwinding from the drum at a given point in the revolution of the drum or reel. 70

2. In a machine of the class described, the combination of a drum or reel adapted to carry a number of sheets of posters which are fastened at their ends to the periphery of the drum, means for revolving the drum and winding the sheets of the posters about the drum, with means for producing a current of air and discharging it at the ends of the sheets for assisting in unwinding the sheets at a given position on the drum, and means for adjusting the position of the discharge of the air as described. 75 80

3. In a machine of the class described, the combination of a reel or drum to which sheets of posters are attached at their ends each sheet being independent of the others, means for revolving the drum slowly, means for discharging an air current on the sheets at their ends for the purpose of separating the sheets as they are wound on the drum. 85 90

4. In a machine of the class described, the combination of a reel or drum to which sheets of posters are attached at their ends each sheet being independent of the others, means for revolving the drum slowly, means for producing and discharging an air current on the sheets at their ends for the purpose of separating them at a given point as they are wound on the drum, and for detaining the sheets from lifting or unwinding until the ends of the sheets have arrived at a given point of the drum. 95 100

5. The combination with a carrier adapted to carry sheets in an endless path about a horizontal axis, of a series of flexible sheets each secured at one margin to the carrier, means for moving the carrier about such axis, whereby the sheets wind in overlapped relation upon the ascending side and tend to fall, by gravity, to pendant position upon the opposite side, and means for injecting air beneath each outer wound sheet as its attached margin reaches a certain point upon the display side of the axis whereby the sheet is caused to unwind and pass quickly to face exposing position. 105 110 115

6. In a machine of the class described, the combination with a carrier adapted to carry, in an endless path about a horizontal axis, sheets each secured by one margin to the carrier, means for actuating the carrier, overlapping and winding the sheets upon each other in that portion of their path lying upon one side of the vertical plane of said axis and allowing them to unwind and pass to vertical pendant position upon the opposite side of such plane, and means for forcibly driving the sheets in succession, as each reaches a given point in the path along which it is moved by the carrier, from over- 120 125 130

lapped position into such pendant position, thus lessening the intervals between complete exposures of successive sheets.

7. In a machine of the class described, the combination of a carrier posters which are attached to the carrier at one end only, to hang below the carrier in display position, with a frame and inclosing parts composed of two portions, the upper portion provided with inclosing walls and the lower one of

open frame work, and the two portions capable of being detached for the purpose described.

In witness whereof I have hereunto signed my name on this 16th day of February, 1910, in the presence of two subscribing witnesses.

WILLIAM ERASTUS WILLIAMS.

Witnesses:

JOHN GRANT,

C. A. ROPER.

---

Copies of this patent may be obtained for five cents each, by addressing the "Commissioner of Patents, Washington, D. C."

---