



US00D429735S

United States Patent [19]

[11] Patent Number: Des. 429,735

Versaw, Jr. et al.

[45] Date of Patent: ** Aug. 22, 2000

[54] **INTEGRALLY FORMED TANK SUMP WITH LID**

[75] Inventors: **Robert H. Versaw, Jr.; James W. Mosier**, both of Muskegon; **Daniel P. Nordstrom**, Twin Lake, all of Mich.

[73] Assignee: **Advanced Polymer Technology, Inc.**, Muskegon, Mich.

[**] Term: **14 Years**

[21] Appl. No.: **29/091,118**

[22] Filed: **Jul. 23, 1998**

Related U.S. Application Data

[63] Continuation-in-part of application No. 29/083,576, Feb. 12, 1998, Pat. No. Des. 404,742.

[51] **LOC (7) Cl.** **15-02**

[52] **U.S. Cl.** **D15/7**

[58] **Field of Search** D15/7-9; 310/87; 73/40, 40.1, 40.5 R, 49.2, 49.5; 285/21; 137/565, 312; 417/411, 424.1, 423.3, 434, 367, 234; 415/199.2

[56] References Cited

U.S. PATENT DOCUMENTS

- D. 309,308 7/1990 Webb .
- D. 313,418 1/1991 Webb .

(List continued on next page.)

FOREIGN PATENT DOCUMENTS

- 150132 5/1951 Australia .
- 200618 10/1955 Australia .
- 1068961 1/1980 Canada .
- 2047354 1/1992 Canada .
- 0944434 11/1948 France .
- 1496531 9/1967 France .
- 0951281 10/1956 Germany .
- 2253857 5/1973 Germany .
- 2226508 12/1973 Germany .
- 3016401 2/1981 Germany .
- 3-51430 3/1991 Japan .

- 0245418 6/1969 Russian Federation .
- 1352272 11/1987 Russian Federation .
- 0424638 5/1967 Switzerland .
- 0209931 1/1924 United Kingdom .
- 0595584 12/1947 United Kingdom .
- 0632756 12/1949 United Kingdom .
- 0667165 2/1952 United Kingdom .
- 1087178 10/1967 United Kingdom .
- 1144475 3/1969 United Kingdom .
- WO 90/04157 4/1990 WIPO .
- WO 90/07074 6/1990 WIPO .
- WO 93/17266 9/1993 WIPO .
- WO 95/09998 4/1995 WIPO .

OTHER PUBLICATIONS

- Total Containment Inc., *Multisided Tank Sumps* (Jul. 1, 1994).
- Total Containment Inc., *Sump/Risers*.
- Total Containment Inc., *Sump/Risers—Installation Instructions* (Apr. 15, 1989).
- Total Containment Inc., *Sump/Riser Installation Instructions for Single Access Lids* (Nov. 23, 1992).
- Total Containment Inc., *Enviroflex—Flexible Double-Wall Piping System* (Mar. 1, 1991).
- Environ Products Inc., *Environ Safe Products—Designed for Future Generations* (1993).

(List continued on next page.)

Primary Examiner—Ralf Seifert
Attorney, Agent, or Firm—Young & Basile, P.C.

[57] CLAIM

The ornamental design for an integrally formed tank sump with lid, as shown and described,

DESCRIPTION

FIG. 1 is an isometric view embodying the ornamental design constituting our invention; FIG. 2 is a top plan view thereof; FIG. 3 is a front elevational view thereof, which is identical to the rear elevational view; FIG. 4 is a bottom plan view thereof; and, FIG. 5 is a right-side elevational view thereof, which is identical to the left-side elevational view.

1 Claim, 3 Drawing Sheets

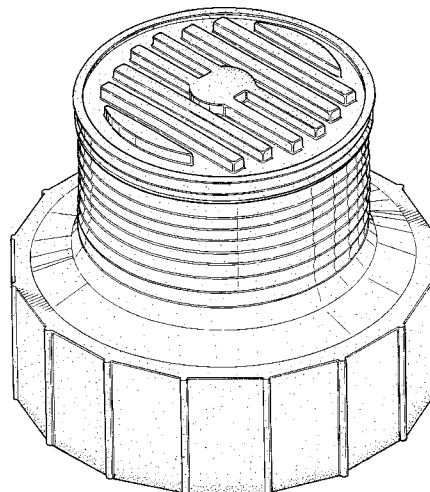

5,263,794 11/1993 Webb .
5,271,518 12/1993 Webb .
5,295,760 3/1994 Rowe .
5,297,896 3/1994 Webb .
5,333,490 8/1994 Webb .
5,366,318 11/1994 Brancher .
5,372,453 12/1994 Argandona .
5,398,976 3/1995 Webb .
5,423,447 6/1995 Youngs .
5,431,457 7/1995 Youngs .
5,481,790 1/1996 Koreis et al. .
5,482,400 1/1996 Bavington .
5,490,419 2/1996 Webb .
5,501,472 3/1996 Brancher et al. .

5,722,699 3/1998 Brancher .

OTHER PUBLICATIONS

Environ Products Inc., Installation Instructions—Deep Burial Sumps (Sep. 1, 1993).

Hofit, *Instructions for the Installation of Hofit Chambers*, pp. A1/17–A17/17.

Owens–Corning Fiberglas, *Piping Sumps—For Secondary Containment of Pumps & Piping* (Installation & Specification), pp. 1–9 (Dec. 1985).

Advanced Polymer Technology Inc., *APT Tech–Notes—Flexible Entry Boot Installation*, Issue 102 (Sep. 1993).

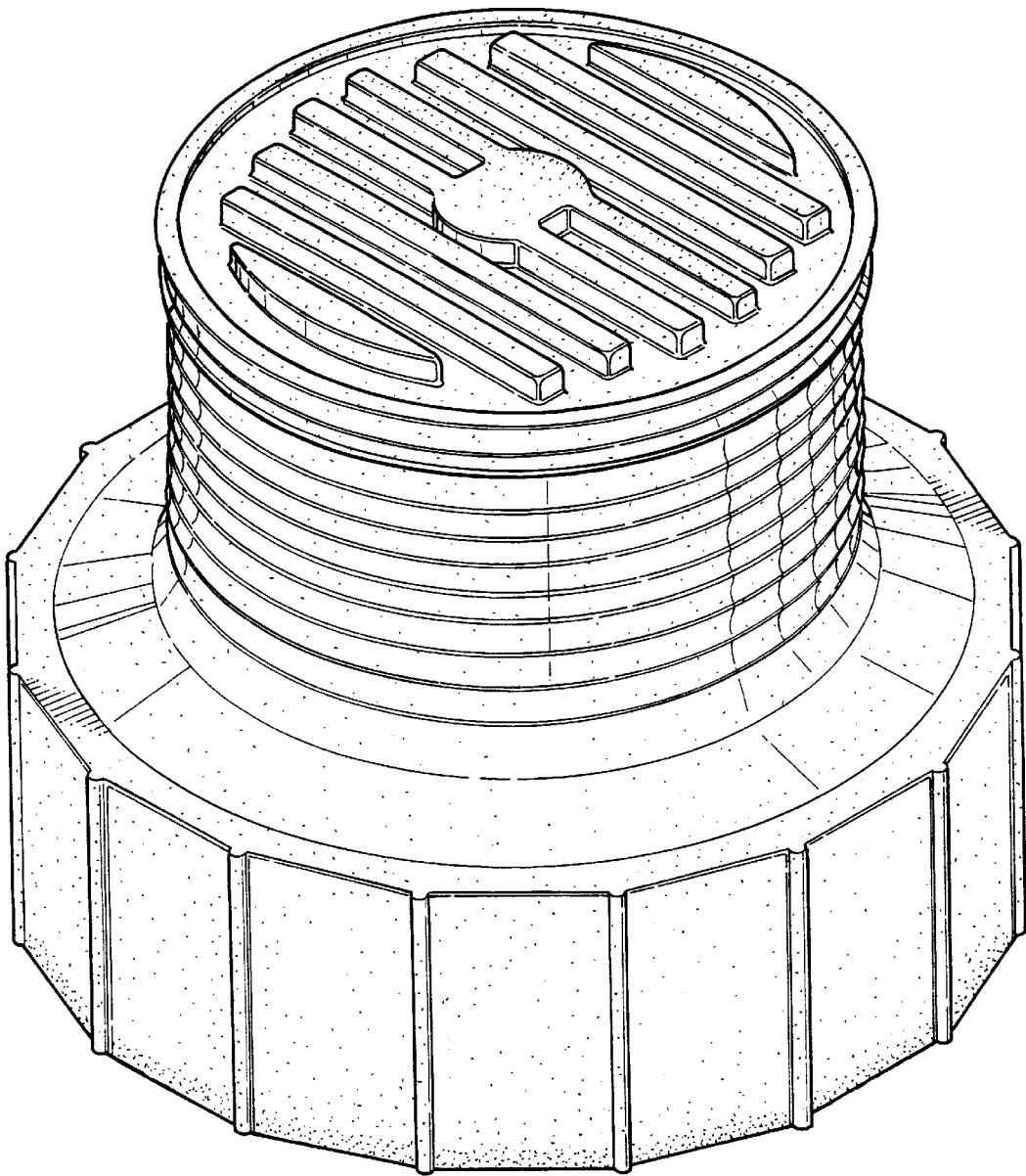

FIG - 1

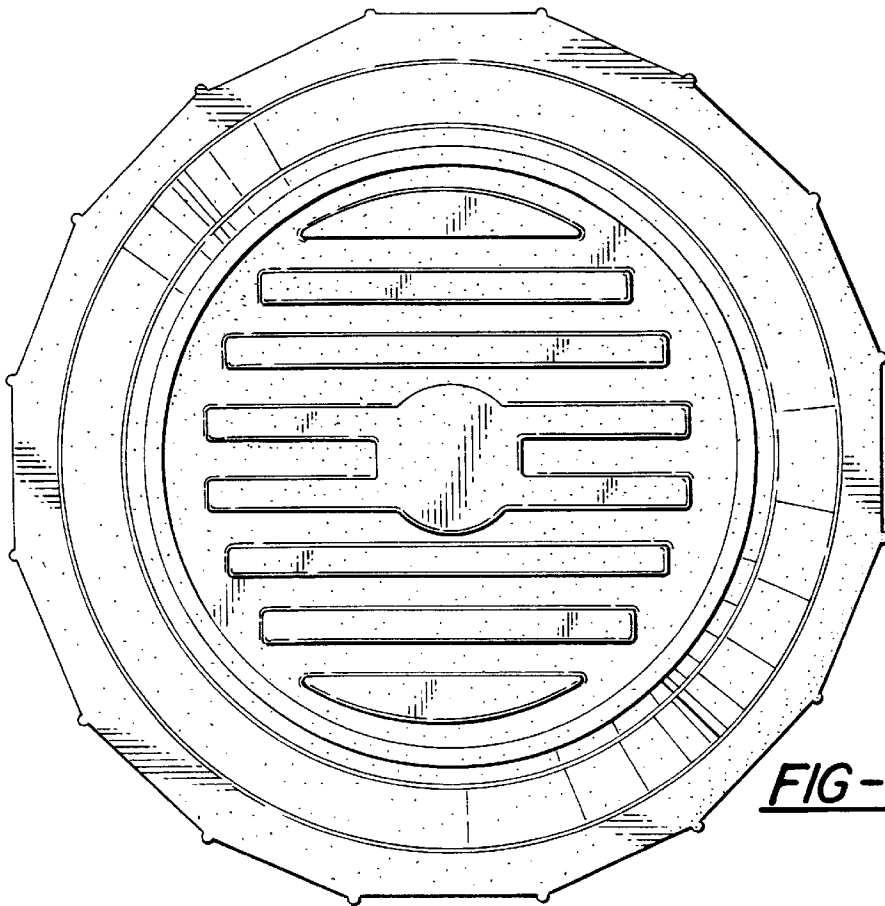

FIG-2

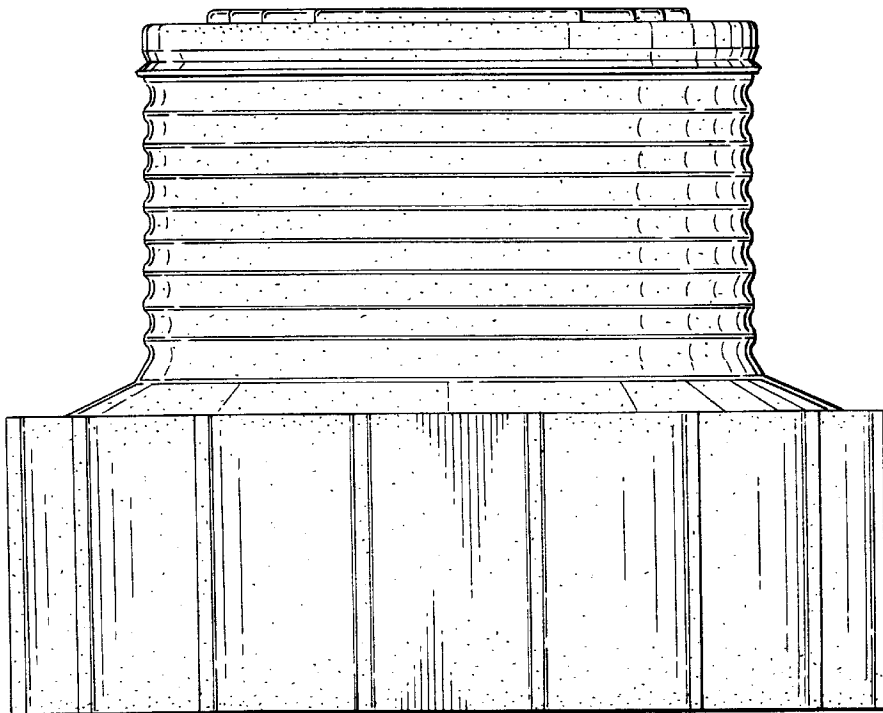

FIG-3

FIG-4

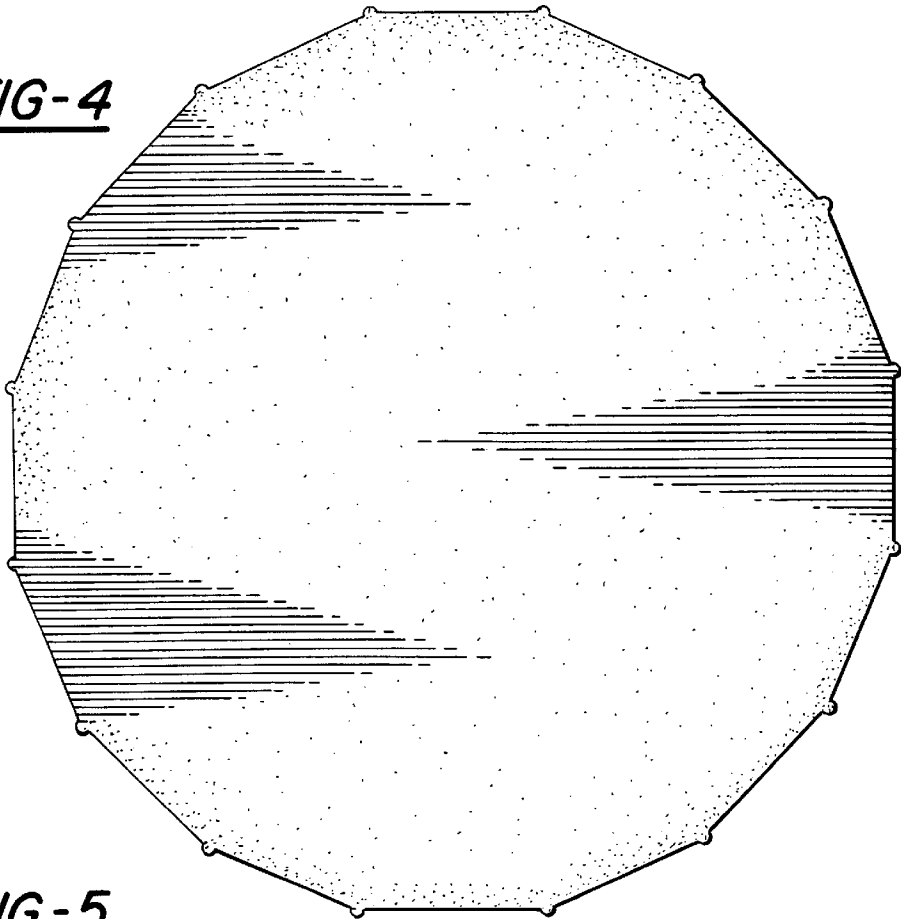

FIG-5

