

(19) World Intellectual Property Organization  
International Bureau



(43) International Publication Date  
27 August 2009 (27.08.2009)

(10) International Publication Number  
**WO 2009/105104 A1**

- (51) **International Patent Classification:**  
A61B 17/88 (2006.01) A61B 17/16 (2006.01)
- (21) **International Application Number:**  
PCT/US2008/054544
- (22) **International Filing Date:**  
21 February 2008 (21.02.2008)
- (25) **Filing Language:** English
- (26) **Publication Language:** English
- (71) **Applicant (for all designated States except US):** IN-TEGRITY INTELLECT, INC. [US/US]; 5850 Hiatus Road, Suite G, Tamarac, TX 33321 (US).
- (72) **Inventors; and**
- (75) **Inventors/Applicants (for US only):** GEIST, Wyatt, Drake [US/US]; 2621 Abiaca Circle, Davie, FL 33328 (US). WALSH, Christopher [US/US]; 9517 Satin Leaf Place, Patkland, FL 33076 (US).
- (74) **Agents:** SLAVIN, Michael, A. et al.; McHale & Slavin, P.A., 2855 Pga Boulevard, Palm Beach Gardens, FL 33410 (US).
- (81) **Designated States (unless otherwise indicated, for every kind of national protection available):** AE, AG, AL, AM,

AO, AT, AU, AZ, BA, BB, BG, BH, BR, BW, BY, BZ, CA, CH, CN, CO, CR, CU, CZ, DE, DK, DM, DO, DZ, EC, EE, EG, ES, FI, GB, GD, GE, GH, GM, GT, HN, HR, HU, ID, IL, IN, IS, JP, KE, KG, KM, KN, KP, KR, KZ, LA, LC, LK, LR, LS, LT, LU, LY, MA, MD, ME, MG, MK, MN, MW, MX, MY, MZ, NA, NG, NI, NO, NZ, OM, PG, PH, PL, PT, RO, RS, RU, SC, SD, SE, SG, SK, SL, SM, SV, SY, TJ, TM, TN, TR, TT, TZ, UA, UG, US, UZ, VC, VN, ZA, ZM, ZW.

(84) **Designated States (unless otherwise indicated, for every kind of regional protection available):** ARIPO (BW, GH, GM, KE, LS, MW, MZ, NA, SD, SL, SZ, TZ, UG, ZM, ZW), Eurasian (AM, AZ, BY, KG, KZ, MD, RU, TJ, TM), European (AT, BE, BG, CH, CY, CZ, DE, DK, EE, ES, FI, FR, GB, GR, HR, HU, IE, IS, IT, LT, LU, LV, MC, MT, NL, NO, PL, PT, RO, SE, SI, SK, TR), OAPI (BF, BJ, CF, CG, CI, CM, GA, GN, GQ, GW, ML, MR, NE, SN, TD, TG).

**Declarations under Rule 4.17:**

— as to applicant's entitlement to apply for and be granted a patent (Rule 4.17(ii))

[Continued on next page]

(54) **Title:** MAGNETIC TARGETING SYSTEM AND METHOD OF USING THE SAME

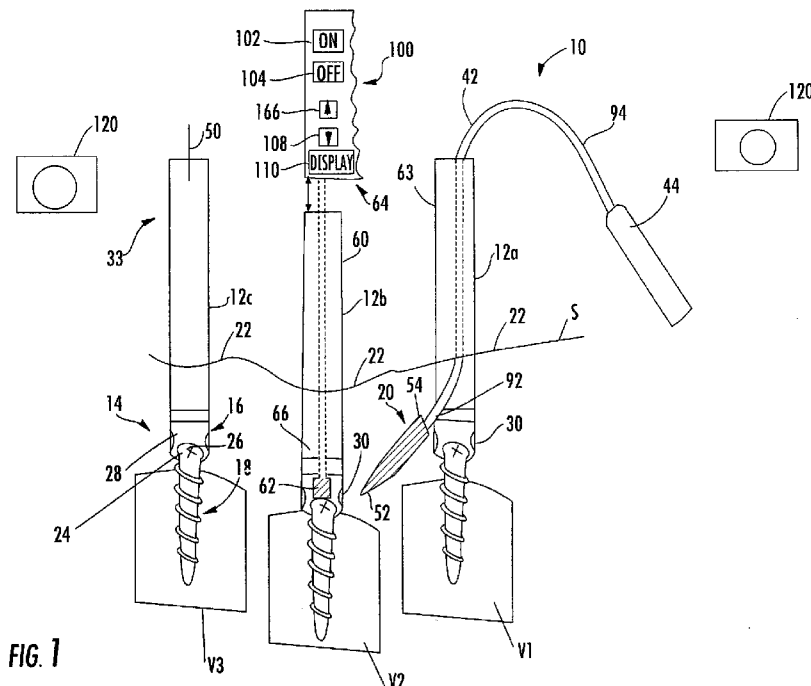

(57) **Abstract:** The present invention describes a magnetic targeting system suitable for guiding a biocompatible device to a target area within the body (*in vivo*) and method of using the same. The system includes a targeting member having a steering material and is attached to the biocompatible device. The system also includes at least one anchoring member constructed and arranged for the inclusion of a magnetic material effective for influencing the traversal of the steering material, *in vivo*. The magnetically influenced anchoring member interacts with the targeting member such that the biocompatible device is positionable relative to the target area.

WO 2009/105104 A1

Published:

— with international search report (Art. 21(3))

## MAGNETIC TARGETING SYSTEM AND METHOD OF USING THE SAME

## FIELD OF THE INVENTION

The invention generally relates to surgical implants; particularly to a system and method for stabilization of adjacent bony structures; most particularly to a system to help  
5 navigate an interconnecting means between multiple bony stabilization devices.

## BACKGROUND OF THE INVENTION

It is widely held that healing and/or structural  
10 correction is greatly facilitated when a bone is stabilized in the proper position. Various devices for stabilization of bone are well known and routinely practiced in the medical arts. For example, an abnormal spine can be stabilized using a substantially rigid or semi-rigid interconnecting means (rod or  
15 plate) and fastening means (screws, clamps, hooks, claws, anchors, or bolts). Multiple fasteners are placed into the spinal pedicle of each vertebra and linked by at least one interconnecting means. One of the more difficult aspects is the surgical insertion of the interconnecting means along a  
20 fixed path of delivery longitudinally along the vertebrae and through each of the multiple fastening means between multiple vertebrae. Once in place, this system substantially immobilizes the spine and promotes bony fusion (arthrodesis).

Traditionally, the surgical techniques for stabilization  
25 of bone required large incisions (upwards of 6 cm in length) and a considerable amount of muscle be cut and stripped away (retracted) from the bone for an "open" visualization of the bone and access thereto for the placement of the fasteners and instrument implantation. Although this so-called "open"  
30 surgical technique has successfully treated non-unions,

instability, injuries and disease of the spine, it is not without disadvantages. Given the invasive nature of this technique, a lengthy healing time and considerable post-operative pain for the patient is common.

5           In response to aforementioned drawbacks, the surgical arts have developed minimally invasive systems and procedures intended to replace the more traditional open surgeries. Obviously, a less extensive system and procedure will eliminate the need to perform much of the cutting and stripping of  
10 muscle, resulting in reduced recovery time and less post-operative pain. As a result, percutaneous procedures have been developed which insert instruments and perform operations through small skin incisions, usually between 1.5 and 5 cm in length, thereby reducing soft tissue damage. However, smaller  
15 skin incisions and smaller surgical fields require more novel and innovative approaches to perform these complicated surgeries.

          One such example of a minimally invasive system is the  
20 SEXTANT Spinal system by Medtronic (Memphis, TN). This device is comprised of two basic components, screw extenders, and the rod inserter, which results in an instrument that looks like a sextant used in naval navigation. The device is an insertion tool that allows fasteners and interconnecting means to be applied to the spine in a minimally invasive manner. The screw  
25 extenders are long shafts used to deliver and attach screws to the vertebrae through small skin incisions. During surgery, these extenders protrude outside the body, allowing the surgeon to arrange and join their ends so that the rod inserter may be attached. The rod inserter is an arc-shaped arm that swings  
30 along a fixed axis and pushes an interconnecting rod through the skin and muscle and into the heads of the implanted fasteners (pedicle screws).

While the aforementioned technique is adequate when the fastening means are well aligned, it fails to deliver the rod when one of the screws is misaligned. Moreover, the interconnecting rod must be pushed by the surgeon along a fixed arch and cannot be directed around neural structures or bony obstructions. One consequence of forcibly pushing the rod through the fastening means is the possibility of colliding the rod with a bony obstruction causing a piece of bone to break off resulting in possible neurological damage. Another common problem is the interconnecting rod becoming disengaged from the rod inserter. When either of these incidents happen, additional surgery is often required to remove the bone fragment and rod from the wound. This may result in the surgeon abandoning the minimally invasive approach and reverting to a traditional approach. Current spinal implant systems do not allow the contour of the rod to match the normal curvature of the surrounding anatomy and such systems are not customizable to meet the individual anatomical variables that each patient presents.

In order to help avoid damaging sensitive anatomy and expedite implant assembly, various image-based navigation systems have been employed which utilize patient images obtained prior to or during the medical procedure to guide a surgeon during the surgery. Recent advances in imaging technology have produced detailed two and three dimensional images using optically guided, fluoroscopic guided, and electromagnetic field based systems. These image-based systems have also been used in combination with the previously described "open" surgeries. One significant problem with most image-based systems is that the radiation generated is transmitted to the patient and surgical staff, which may result in physiological damage over time. Also, the cost and

portability of this equipment continue to be an issue. In addition, these systems often require the surgeon undergo extensive training to operate correctly.

Accordingly, a need exists in the surgical arts for a system and minimally invasive procedure capable of providing optimal mechanical support and bony fusion, while reducing the likelihood of bone damage and neural functioning when compared to the currently available interconnecting elements. It is also desirable to provide a surgical procedure that can be performed in conjunction with, but does not require, an image-based tracking system.

#### PRIOR ART

Although there are numerous patents directed to systems and methods for insertion of a stabilizing implant at a selected area of an anatomy, the prior art nevertheless fails to teach a targeting system for the insertion of an implant using minimally invasive techniques having a decreased risk of causing damage to neural structures or bony obstructions using minimal, if any, radiation exposure to the patient and/or surgeon.

For example, U.S. Publication No. 2005/0085714 to Foley et al., discloses a method and apparatus for percutaneous and/or minimally invasive implantation of a construct (e.g., spinal implant). The construct may be implanted using a navigation system for planning and execution of a procedure. A plurality of portions of the construct may be interconnected using locations and paths determined and navigated with the navigation system. The navigation system utilizes optical or electromagnetic localization to determine the precise location of a selected implant construct or instrument. An optical localizer can be positioned relative to an extender attached to

a screw. Alternatively, a coil may be positioned in an electromagnetic (EM) field such that the position of the coil may be determined by sensing the induced voltage. A computer is used to form a plan prior to implantation of the construct and thereafter track the various portions of the construct during insertion. The plan and the tracking of the surgery are displayed on a monitor to provide guidance to the surgeon.

U.S. Publication No. 2005/0277934 to Vardiman, discloses a minimally invasive spinal fixation system used for spinal arthrodesis (bony fusion) or motion preservation. The system comprises a plurality of pedicle screws, including a first screw placed into a first vertebral body, and a second screw placed into a second vertebral body, a connector for attaching to the first and second screws and, a removable guide for percutaneously attaching the connector to the first and second screws. According to one embodiment, detectional spheres are positioned on the head of screw extenders and on the handle of the rod insertion tool. A comparator calculates the relative position of the insertion tool handle with respect to the screw extenders and provides a visual display for the surgeon.

U.S. Patent No. 6,236,875 to Bucholz, discloses surgical navigation systems including reference and localization frames. The system generates an image representing the position of one or more body elements during the procedure using magnetic resonance imaging (hereinafter, MRI) or computed tomography (hereinafter, CT) scan images taken prior to the surgery. The body elements and their relative position are identified during the procedure. The position of the known body elements can then be manipulated using a computer to the relative position of the patient during the surgery. The manipulated data can then be utilized to guide the surgeon for implantation.

U.S. Patent No. 6,226,548 to Foley et al., discloses an

apparatus and procedures for percutaneous placement of surgical implants and instruments such as, for example, screws, rods, wires and plates into various body parts using image guided surgery. The invention includes an apparatus for use with a surgical navigation system, an attaching device rigidly connected to a body part, such as the spinous process of a vertebra, with an identification superstructure rigidly but removably connected to the attaching device. This identification superstructure, for example, is a reference arc and fiducial array which accomplishes the function of identifying the location of the superstructure, and, therefore, the body part to which it is fixed, during imaging by CT scan or MRI, and later during medical procedures. The system utilizes emitters such as light emitting diodes (hereinafter, LEDs), passive reflective spheres, acoustics, magnetics, electromagnetics, radiologic, or micro-pulsed radars for indicating the location of a body part to which the emitter is attached.

U.S. Patent No. 7,011,660 to Sherman et al., discloses a brace installation instrument and method for the stabilization of bony structures. The installation instrument is sextant-type tool with anchor extensions coupled to the anchors. The instrument is movable with respect to the anchors to position a brace in a position proximate to the anchors. The brace can be indexed for insertion at a predetermined orientation with respect to the installation instrument.

All of the aforementioned prior art disclose a system which utilize an implant insertion means to forcibly push the surgical implant or instruments to the target area *in vivo*. This increases the possibility of pathway divergence and/or damage to neural and vascular structures. What has been heretofore lacking in the prior art is a simple and economical

system and procedure for the accurate and precise placement of surgical implants and/or instruments at a target area while providing a decreased risk to neural and vascular structures. Moreover, none of the aforementioned references provide audible and/or tactile feedback to the surgeon that indicate the target area has been reached.

#### SUMMARY OF THE INVENTION

The instant invention is related to a magnetic targeting system suitable for guiding a biocompatible device, (implant, surgical instrument) to a target area within the body (*in vivo*), be it a tumor or implantation point for a fastening means. The system includes a targeting member that includes a steering material. The targeting member is attached at one end to the biocompatible device. The system also includes at least one anchoring member constructed and arranged to secure to a target area *in vivo* at one end and the other end constructed and arranged for inclusion of a magnetic material effective for influencing the traversal of the steering material *in vivo*. The magnetically influenced anchoring member interacts with the steering material of the targeting member such that the connected biocompatible device is positionable relative to the target area.

It therefore an objective of the instant invention to provide a system that minimizes soft tissue damage and provides less post-operative pain.

It is a further objective of the instant invention to provide a targeting system that provides real time targeting by providing feedback as to the position of the biocompatible device.

Yet another objective of the present invention is to disclose a feedback system that utilizes audio and/or tactile

feedback to indicate to the surgeon when the target area is reached.

Another objective of the present invention is to provide a magnetic targeting system that can penetrate tissue without being distorted or causing physiologic damage, unlike x-rays.

Still a further objective of the invention is to teach a targeting system which allows for shorter surgery, decreased x-ray exposure, and fewer complications for the patient.

Yet another objective of the instant invention is to provide a targeting system that is simple to operate to reduce the training the surgeon must undergo for operation of peripheral systems.

These and other objectives and advantages of this invention will become apparent from the following description taken in conjunction with any accompanying drawings wherein are set forth, by way of illustration and example, certain embodiments of this invention. Any drawings contained herein constitute a part of this specification and include exemplary embodiments of the present invention and illustrate various objects and features thereof.

#### BRIEF DESCRIPTION OF THE FIGURES

FIG. 1 illustrates a partial side view of a portion of a patient's spine which includes magnetic targeting system according to a preferred embodiment of the invention;

FIG. 2 is the magnetic targeting system as shown in FIG. 1, illustrating the targeting member with attached tethering means threaded through an anchor member;

FIG. 3 is the magnetic targeting system shown in FIG. 1, illustrating the targeting member being removed from the interior of the patient through the last extender;

FIG. 4 is the magnetic targeting system as shown in FIG.

1, illustrating the insertion of the biocompatible device between adjacent vertebrae;

FIG. 5 is a partial cross-sectional view of a portion of the extender removably attached to the connector portion of the multi-axial screw in accordance with one embodiment;

FIG. 6 is an upper perspective view of a multi-axial screw that can be used in system of the present invention;

FIGS. 7a thru 7e illustrate various embodiments of the targeting member used in the instant invention;

FIG. 8 is a partial side view of portion of the spine of a patient which includes the magnetic targeting system according to another embodiment illustrating the insertion of the targeting member *in vivo* without the use of extenders; and

FIG. 9 illustrates a partial side view of a portion of a patient's spine which includes magnetic targeting system according to another embodiment of the invention using a permanent magnet.

#### DETAILED DESCRIPTION OF THE INVENTION

Detailed embodiments of the instant invention are disclosed herein, however, it is to be understood that the disclosed embodiments are merely exemplary of the invention, which may be embodied in various forms. Therefore, specific functional and structural details disclosed herein are not to be interpreted as limiting, but merely as a basis for the claims and as a representation basis for teaching one skilled in the art to variously employ the present invention in virtually any appropriately detailed structure.

Referring now to FIGS. 1-9 which illustrate the magnetic targeting system **10** of the present invention suitable for facilitating navigation to a target area, wherein like elements

are numbered consistently throughout. FIG. 1 shows a plurality of anchoring members **14** (also referred to as fastening means). The anchoring members are depicted here as multi-axial pedicle screws, each removably attached to an extender **12a**, **12b**, **12c**.  
5 These screws have a proximal end **16** and a distal end **18**. The proximal end includes head portion **24** with a tool opening **26** configured to receive a driving tool (not shown). The distal end includes a threaded shank designed to secure to a selected target area located inside the body of a patient (*in vivo*),  
10 shown here as consecutive spinal vertebrae V1, V2, V3. Although the target area is exemplified here as vertebrae in a partial spinal column the target area may be located anywhere *in vivo*.

The screw shown here is a multi-axial screw where the proximal end of the screw may include a connector **28** rotatably  
15 connected to the head portion **24** of the screw. That is, the connector is capable of 360 degree rotation relative to the threaded shank **27** of the screw along the axis **L** of the shank and angular motion defined by the angle  $\alpha$  (Fig. 5). One example of a suitable multi-axial screw is described in U.S.  
20 Patent No. 5,797,911, herein incorporated by reference. Although a multi-axis is exemplified herein, it is contemplated that a fixed axis screw may be used. Fixed-axis screws do not include a rotatable connector **28**. Other means for anchoring are also contemplated herein, some of which include, clamps, hooks,  
25 claws, bolts, or the like. Moreover, the shank of the anchor member may or may be not be cannulated, as is known in the art.

As shown in FIGS. 5 and 6, the connector portion of the screw is constructed and arranged to form a passageway **30** designed to removably receive implants of various sizes. The  
30 connector portion includes an opening **43** constructed and arranged to receive a set screw **38**. As shown in FIG. 6, the

head portion includes threaded interior sidewalls **46** designed to mate with external threads **38** formed on the set screw. Thus, as the set screw is threadably lowered along the connector portion of the screw the passageway **30** in the connector is narrowed. The passageway is narrowed until the exterior surfaces of the biocompatible device **44** (shown here as interconnecting rod, see FIGS. 1-4) are sandwiched between the upper portion of the screw head **24** and the set screw. This acts to reliably secure the biocompatible device onto the screw. As with the head of the screw, there should be a tool opening **40** configured to receive a driving tool (not shown) inserted within the interior portion **74** of the extenders. The driving tool is well known in the surgical arts and is used to rotatably secure the set screw to the desired position within the interior of the connector.

As discussed above, the distal end **34** of each of the hollow extenders **12a, 12b, 12c** are removably attached to the screws by any appropriate means known in the art. For example, the extender may include a depressible member (not shown) located at the proximal end **33** of the extender that is operatively connected to an internal clamping member located that the distal thereof. The clamping member is capable of engaging and disengaging the connector portion of the screw. One example of a suitable extender which could be used in the present invention is disclosed in U.S. Patent No. 7,011,660, herein incorporated by reference. The extender may also be able to rotate the connector of a multi-axial screw relative to the shank to facilitate the threading of the interconnecting rod therethrough.

The extenders should be made of a substantially rigid biocompatible material and have a length dimension (along its

longitudinal axis **50**) that allows the proximal end **33** to protrude a distance outside of the percutaneous exposure **22** created through the outer skin **S** of the patient. According to a preferred embodiment, at least the first extender should have a "c-shape", as seen along an axis transverse its longitudinal axis, thereby defining a slot **63** that extends along its longitudinal axis **50** and into the patient when attached to the screw. The slot should be sized to allow the targeting member to exit, so that it is able to be delivered percutaneously, as shown in FIG. 1. The interior dimension **76** of the extenders should be such that they are capable of receiving the appropriate driving tool (not shown) used to engage the screws and set screws. In addition, the interior dimension of the extenders should be able to accept a removable magnetic device **60** for magnetically influencing the anchor members **14**, as described further below.

Referring again to FIGS. 1-4, a targeting member is shown attached to biocompatible device **44** by a tethering means **42**. The targeting member has a first end **52** and a second end **54**. The first end is designed to penetrate the tissue and is shaped to enlarge the opening while creating a pathway through the tissues as the targeting member is advanced *in vivo*. At least the first end of the targeting member is composed of a steering material capable of being magnetically influenced, as described hereafter.

As shown in non-limiting embodiments of FIGS. 7a-e, the targeting member **20** may be made from a flexible, semi-rigid, or rigid material, each includes the steering material **84** located on the first end. FIG. 7a illustrates an embodiment of a semi-rigid targeting member in the form of rod-like member with steering material **84** disposed on its first end **52**. The first

portion **78** of the rod is made of a flexible material capable of safely colliding with bony or neural obstructions without causing damage. Fig. 7b illustrates another flexible rod formed of a plurality of rigid consecutive segments **80** through which the tethering means **42** extends to the first end (not shown).  
5 When the surgeon pulls the tethering member at the second end taut, the segments are forced together and little movement is permitted between the segments. In the embodiment of FIG. 7c, the entire targeting member is composed of or coated with a  
10 second biocompatible steering material **86**. FIG. 7d illustrates another embodiment wherein the targeting member includes a ball joint **88** attached to the tethering means. As with the embodiment of FIG. 7b, the tension in the tethering member controls the amount of pivot at the ball joint. Thus, when tension is  
15 released the rod comes flexible and the first end of the targeting member pivots on the ball. Alternatively, when the tension is reapplied to the tethering means, the rod is solid again. This way the surgeon is able to safely guide the targeting member around neural and bony obstructions as it moves  
20 through the body. Lastly, FIG. 7e depicts a rigid rod-like member formed from a solid biocompatible material **90**.

The tethering means **42** may be made of any flexible or semi-flexible biocompatible material capable of allowing the device to navigate around neural and bony obstructions without damaging  
25 them. Examples of suitable tethering means may be in the form of a cable, cord or ligament. Moreover, the tethering means may be formed of a cannulated or solid member. As discussed above, the first end **92** of the tethering means is attached to the second end **54** of the targeting member by any means of attachment  
30 known in the art. Similarly, the second end **94** of the tethering means is attached to the biocompatible device **44** by any means

of removable connection known in the art. For example, the biocompatible device and tethering means could include corresponding threads that the surgeon can rotate to disconnect the tethering means from the biocompatible device.

5           According to a preferred embodiment, the biocompatible device is shown as an implantable interconnecting rod. The rod may be rigid, semi-rigid or flexible. Rigid rods are usually preferred for providing the necessary stability during the healing process and arthrodesis, however, flexible rods have  
10           been found to provide for arthrodesis while allowing some movement between bony structures that have been interconnected to preserve some motion. Moreover, like the tethering means the biocompatible device may also be solid or cannulated.

          Although the interconnecting rod is shown in FIGS 1-4 as  
15           interconnecting two pedicle screws, the surgeon could use any appropriately sized rod having a length dimension capable of interconnecting three or more fastening means co-linearly implanted along multiple vertebrae. It is also within in the purview of the invention that any sized rod having various  
20           widths or diameters could be used so long as it is capable of stabilizing the bony structures for bony fusion. Although a rod-like member is exemplified herein, other such biocompatible devices known to one skilled in the art are also contemplated, for example, plates, clamps, etc.

25           FIG. 4 illustrates a hollow or cannulated flexible biocompatible device in fluid communication with a cannulated tethering means. According to this embodiment, once the rod has been properly inserted into the desired location, the surgeon can use an insertion means **96** (syringe or the like) to supply  
30           a biocompatible hardening material (e.g., cement, carbon, bone matrix) through the tethering means and into the interior of the hollow rod. Although not required, the biocompatible device

might also be made permeable and used to deliver constituents supplied by the insertion means to the target area (e.g., bone growth/fusion material, medication, curing material, etc.).

As shown in FIGS. 1-4, each of the proximal ends of the extenders **12a-c** protrude outside of the patient's skin through percutaneous incisions **22** so that the surgeon is able to insert instrumentation through the extender's interior portion to access the screw secured to the target area (vertebra). The extenders also enable the surgeon to insert the magnetic device or wand **60** into the selected extender to a position proximate the corresponding anchor **14**. The magnetic device includes a proximal **64** and a distal end **66**. Magnetic material **62** is attached at the distal end of the device and the proximal end may include a grip **100** (not required) for the surgeon to hold the magnetic device. The wand should be sized to extend the length of the extender.

The "magnetic material" **62** as used herein refers to either a permanent magnet (as shown in FIG. 9) or an electromagnet (shown in FIGS. 1-4) which generates a magnetic field capable of influencing the steering material in the targeting member *in vivo*. As is known in the art, an electromagnet is a magnet in which the magnetic field is produced by a flow of electrical current. One example of a suitable permanent magnet is a Neodymium Iron Boron (NdFeB) magnet since it is powerful and has been approved by the U.S. Food and Drug Administration (FDA) for internal use. Another example is the use of a recently developed biocompatible non-metallic magnet, or plastic magnet, made from the polymer PANiCNQ which is combination of emeraldine-base polyaniline (PANI) and tetracyanquinodimethane (TCNQ).

The "steering" material in the target member, as used herein, refers to any material capable of being influenced by the magnetic material **62**. For example, the steering material may include any magnetically attractive material or alloy, (e.g. steel, iron, etc). The steering material may be the same or different than that used for magnetic material **62** so long as it is capable of being influenced, e.g., attracted or repelled. Moreover, either or both the magnetic material and the steering material may be coated with any suitable biocompatible element, such as plastic. The type, shape, and size of the magnetic material and steering material should be suitable for internal use in patients and provide the optimal magnetic field. Magnetic fields are used herein for navigating *in vivo* since these fields can penetrate human tissue and bone without being distorted similar to x-rays, but without the danger of radiation and physiologic damage.

According to a preferred embodiment shown in FIGS. 1-4, the magnetic material employs an electromagnet having controls located in the handle or grip **100**. At a minimum, the controls should include buttons and associated circuitry that will allow the surgeon to turn the electromagnet on **102** and off **104**. Preferably, the controls also include buttons and circuitry capable of increasing **106** or decreasing **108** the strength of the magnetic field generated by the electromagnet and/or switch between polarity (north and south poles). As is known, the polarity of a magnet allows it to attract or repel magnetic material within its magnetic field. The controls can also include a display **110** used to indicate the strength of the magnetic field being applied.

The method of using the magnetic targeting system **10** of the present invention is described in accordance with the embodiment depicted in FIGS. 1-4. First, the anchoring member

14 (shown here as the multi-axial pedicle screw) is inserted into the desired target area (shown here as vertebra), as is known in the surgical art. The screw may be removably attached to the distal end of the extender before or after attachment of the screw to the selected vertebrae. Once attached, the surgeon inserts the targeting member into the proximal end of the extender which protrudes outside of the percutaneous exposure 22. The magnetic device is inserted into the next vertebra V2 which includes the anchoring member (extender and screw), shown here as 12b. The magnetic material 62 is disposed proximate the target area via wand 60. According to this example, the magnetic material is placed inside the connector portion of the screw, this may be done prior to, during, or after the targeting member is inserted into the extender. If an electromagnet is used, the surgeon will switch on the electrical current to begin generating an attractive magnetic field when in the proper position *in vivo*. If a permanent magnetic is used for the magnetic material 62, the surgeon simply places it inside the connector portion of the screw, see FIG. 9.

As a result of the attractive magnetic field, the steering material in the targeting member is pulled through the extender slot 63. The strength of the magnetic field generated by the magnetic material should be capable of pulling the targeting member (including attached tethering mean) toward the magnetic member such that the pointed first end penetrates the tissue and creates a pathway through the tissues as the targeting member is advanced toward the magnetic material. The use of the magnetic field to guide the targeting member, as compared to forcibly pushing the targeting member, as disclosed in the prior art, reduces the probability of damaging neural structures or breaking bony obstructions encountered along its path.

Once the targeting member has reached the magnetic material **62** positioned inside the connector portion of the screw, the surgeon removes it from the anchoring member and places it into the next anchoring member (extender and screw), shown here as **12c** attached to vertebra V3. The aforementioned procedure is then repeated inside anchoring member **12c**. If an electromagnet is used, the electricity along the magnetic member is turned on and the strength of the magnetic field generated pulls the targeting member through the passageway **30** of the screw secured to V2 and toward the magnetic member located inside the screw secured to V3, see FIG. 2. If a permanent magnet is used, the surgeons simply places the distal end inside the connector portion of the anchor.

As described before, the pointed first end of the target member penetrates the tissue and creates a pathway through the tissues as it moves toward the magnetic material. This technique of threading through the screw does not require the surgeon to try to align multiple pedicle screws along the fixed path of the rod. Moreover, the continuous magnetic attraction of the targeting member toward the pedicle screw reduces the possibility that the target member will be diverted by structures in the anatomical topography that may cause it to penetrate unintended areas. In addition, the present invention allows the surgeon to avoid a given anchor member. In such a circumstance the surgeon can insert the magnetic material into that extender connected to the anchor member that is to be avoided. The magnetic material maybe either a permanent magnet or electromagnet having the same polarity as that of the targeting member. This will repel the steering material of the target member from that target area.

Once the final vertebra is reached, the magnetic member is used to pull the targeting member through the slot in the upper opening **43** of the pedicle screw and along the interior length

of the extender until it reaches the proximal end protruding out of the incision. The surgeon can then grasp the targeting member and attached tethering means, see FIG. 3. The tethering means located outside the patient is then used by the surgeon to  
5 gently pull the attached biocompatible member (rod) along the path formed through the tissue by the targeting member and through the connector portion of the pedicle(s) until the biocompatible member reaches the last vertebra, as shown in FIG. 4.

10 If the tethering means and interconnecting rod are hollow, the user can disconnect the targeting member and releasably attach an injection means **96** thereto. The injecting means can be used into supply any suitable any flowable, biocompatible material inside the rod. One example of a suitable biocompatible  
15 material includes at least one a hardening material that will cause the rod to become rigid.

Otherwise, the rod might be filled prior to the introduction of a hardening material. For example, the rod might contain ferroelectric material that allows the rod to remain  
20 flexible during insertion process until exposed to an electric current. This is particularly suitable if used in conjunction with the electromagnet embodiment previously described. Once the flexible rod is positioned at the final desired location (secured to pedicle screws), the rod may then be exposed to  
25 electric current in the electromagnet by inserting the magnetic means into the extenders. The electric current causes the ferroelectric material to harden to make a substantially rigid rod. Thus, the contour of the rod corresponds to the natural curvature of the surrounding anatomy.

30 As discussed above, the connector portion of the screw is constructed and arranged to receive a set screw **32** therein. The set screw is inserted into each of the extenders and threadably attached by the driving tool (not shown) positioned in the

extender and inserted in tool opening in the screw. The interconnecting rod **44** is sandwiched between the upper portion of the head and the set screw. This acts to secure the rod onto the screws. The extenders are then removed from the connector  
5 portion of the screw and the exposures closed.

Referring to an alternative embodiment shown in FIG. 8, the targeting system of the present invention does not require the use of an extension member for insertion of the targeting member *in vivo*. The anchoring member may be implanted  
10 and the exposure closed with no external access thereto. The proximal end of the implanted anchoring member may include either a permanent magnet or a remotely controlled electromagnet, as is known in the art. Thus, the targeting member **20** may be directly inserted and fed into the body through  
15 an incision created by the surgeon. As with the previous embodiments, the magnetic portion of the anchoring member is capable of attracting or repelling the targeting member placed inside the patient.

Any of the aforementioned embodiments of the system and techniques of the present invention can employ any type of known  
20 imaging system to determine and locate placement of any of the aforementioned structures *in vivo*. For example, insertion of the anchor member into the bony structure can be pre-planned by CT scan, x-ray, or the imaging means known in the art.

The present system may also include a feedback system having at least one detection element **120** (two are shown in FIG. 1) disposed outside and proximate the patient to determine the position of the targeting member and/or biocompatible member in  
25 real-time. According to one, albeit non-limiting embodiment, the detection element is an audio receiver or pickup capable of audibly detecting when the targeting member and magnetic means connect or "click" together. This way, the surgeon can  
30 imagelessly determine that the targeting member has reached the

magnetized portion of the anchoring member. This may be used in conjunction with a tactile sensation produced when the targeting member and magnetic means connect. This tactile sensation of the two elements meeting will be felt by the person holding the tethering means.

Although the invention is described with reference to stabilization and fusion of adjacent spinal vertebrae, it is hereby contemplated that devices and methods disclosed herein could be used in all types of joints (ankle, interdigital, etc) found in the human or animal body. Although a rod-like member is exemplified herein, other such biocompatible devices known to one skilled in the art are also contemplated, for example, plates, clamps, etc.

All patents and publications mentioned in this specification are indicative of the levels of those skilled in the art to which the invention pertains. All patents and publications are herein incorporated by reference to the same extent as if each individual publication was specifically and individually indicated to be incorporated by reference.

It is to be understood that while a certain form of the invention is illustrated, it is not to be limited to the specific form or arrangement herein described and shown. It will be apparent to those skilled in the art that various changes may be made without departing from the scope of the invention and the invention is not to be considered limited to what is shown and described in the specification and any drawings/figures included herein.

One skilled in the art will readily appreciate that the present invention is well adapted to carry out the objectives and obtain the ends and advantages mentioned, as well as those inherent therein. The embodiments, methods, procedures and techniques described herein are presently representative of the preferred embodiments, are intended to be exemplary and are not intended as limitations on the scope. Changes therein and other

uses will occur to those skilled in the art which are encompassed within the spirit of the invention and are defined by the scope of the appended claims. Although the invention has been described in connection with specific preferred  
5 embodiments, it should be understood that the invention as claimed should not be unduly limited to such specific embodiments. Indeed, various modifications of the described modes for carrying out the invention which are obvious to those skilled in the art are intended to be within the scope of the  
10 following claims.

## CLAIMS

What is claimed is:

Claim 1. A magnetic targeting system suitable for facilitating navigation to a target area located *in vivo*, said system comprising:

a targeting member having a first end and a second end, said second end constructed and arranged for attachment to a biocompatible device and at least said first end includes a steering material influenced by a magnetic field; and

at least one anchoring member having a proximal end and a distal end, said distal end constructed and arranged to secure to a target area located *in vivo*, wherein said proximal end is constructed and arranged for inclusion of a magnetic material effective for influencing the traversal of said steering material *in vivo*;

whereby, the magnetically influenced proximal end of said anchoring member interacts with said first end of said targeting member such that said connected biocompatible device is positionable relative to said target area.

Claim 2. The magnetic targeting system of claim 1, wherein said at least one anchoring members includes a plurality of anchoring members each capable of independently influencing said target member by inclusion of said magnetic material.

Claim 3. The magnetic targeting system of claim 1, wherein said system includes a real-time feedback mechanism to verify location *in vivo* of said biocompatible device.

Claim 4. The magnetic targeting system of claim 3, wherein said real-time feedback mechanism includes tactile feedback to verify location *in vivo* of said biocompatible device.

Claim 5. The magnetic targeting system of claim 1, wherein said magnetic material is an electromagnet.

Claim 6. The magnetic targeting system of claim 1, wherein said magnetic material is a permanent magnet.

Claim 7. The magnetic targeting system of claim 1 wherein said biocompatible device is an implant or surgical instrument.

Claim 8. The magnetic targeting system of claim 1 wherein said biocompatible device is formed from a material selected from the group consisting of rigid, semi-rigid, or flexible.

Claim 9. The magnetic targeting system of claim 1, wherein said anchor member is a fastening means for attaching to a bony structure and said biocompatible device is a interconnecting means.

Claim 10. The magnetic targeting system of claim 1, wherein said targeting member is formed from a material selected from the group consisting of rigid, semi-rigid, or flexible.

Claim 11. A method for facilitating navigation to a target area *in vivo*, said steps comprising:

providing a targeting member having a first end and a second end, said second end attached to a biocompatible device, wherein said first end includes a steering material influenced by a magnetic field;

attaching to a target area *in vivo* at least one anchoring member having a proximal end and a distal end, wherein said anchoring member is attached to said target area at its distal end; and

introducing a magnetic material into said proximal end of said anchoring member capable of influencing the traversal of said steering material, thereby positioning said biocompatible device relative to said target area.

Claim 12. The method as set forth in claim 11, wherein said at least one anchoring members includes a plurality of anchoring members each capable of independently influencing said target member by inclusion of said magnetic material.

Claim 13. The method as set forth in claim 11, wherein said system includes a real-time feedback mechanism to verify location *in vivo* of said biocompatible device.

Claim 14. The method as set forth in claim 13, wherein said real-time feedback mechanism includes tactile feedback to verify location *in vivo* of said biocompatible device.

Claim 15. The method as set forth in claim 11, wherein said magnetic material is a electromagnet.

Claim 16. The method as set forth in claim 11, wherein said magnetic material is a permanent magnet.

Claim 17. The method as set forth in claim 11 wherein said biocompatible device is an implant or surgical instrument.

Claim 18. The method as set forth in claim 11 wherein said biocompatible device is formed from a material selected from the group consisting of rigid, semi-rigid, or flexible.

Claim 19. The method as set forth in claim 11, wherein said anchor member is a fastening means for attaching to a bony structure and said biocompatible device is a interconnecting means.

Claim 20. The method as set forth in claim 11, wherein said targeting member is formed from a material selected from the group consisting of rigid, semi-rigid, or flexible.



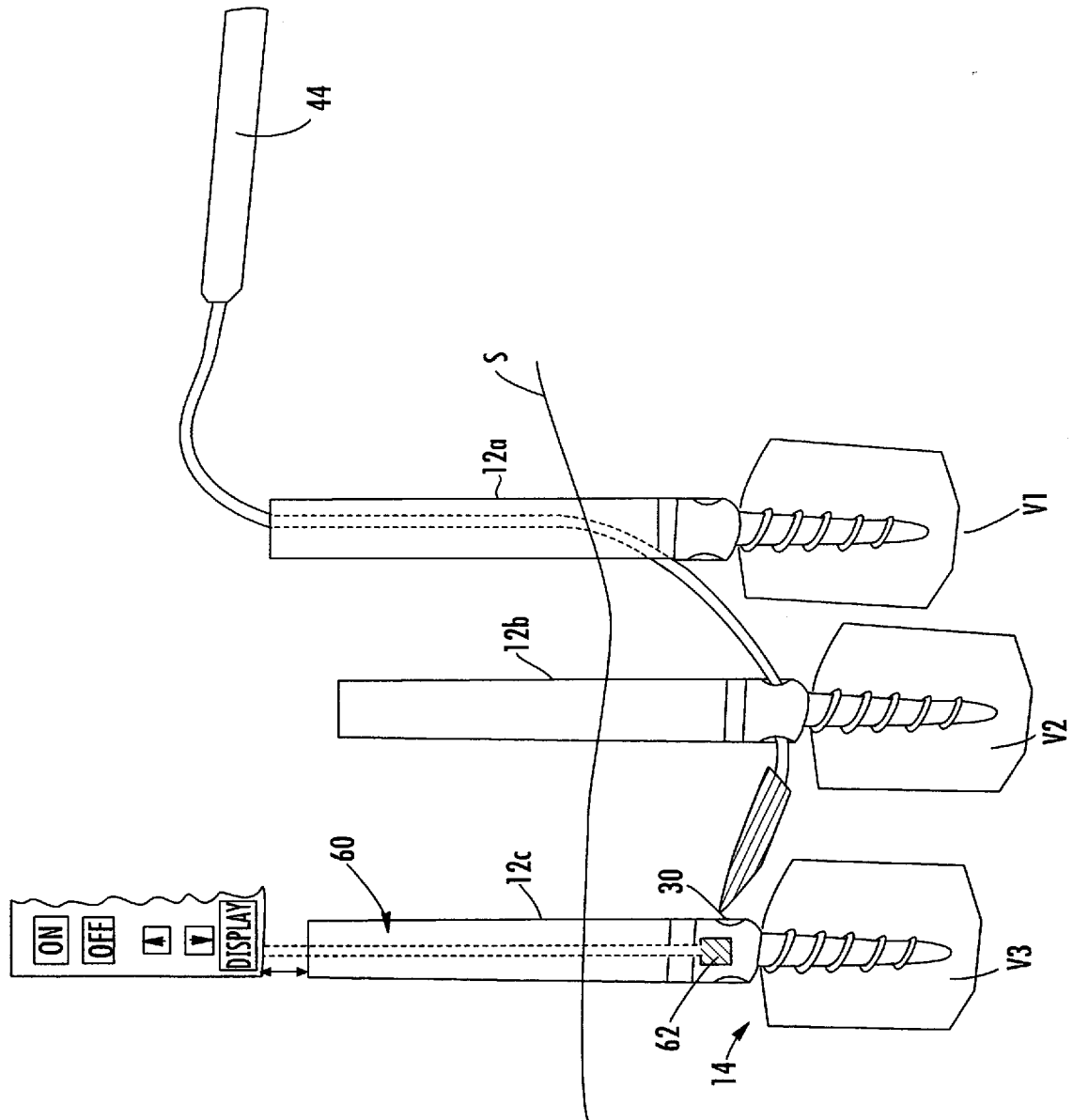

FIG. 2



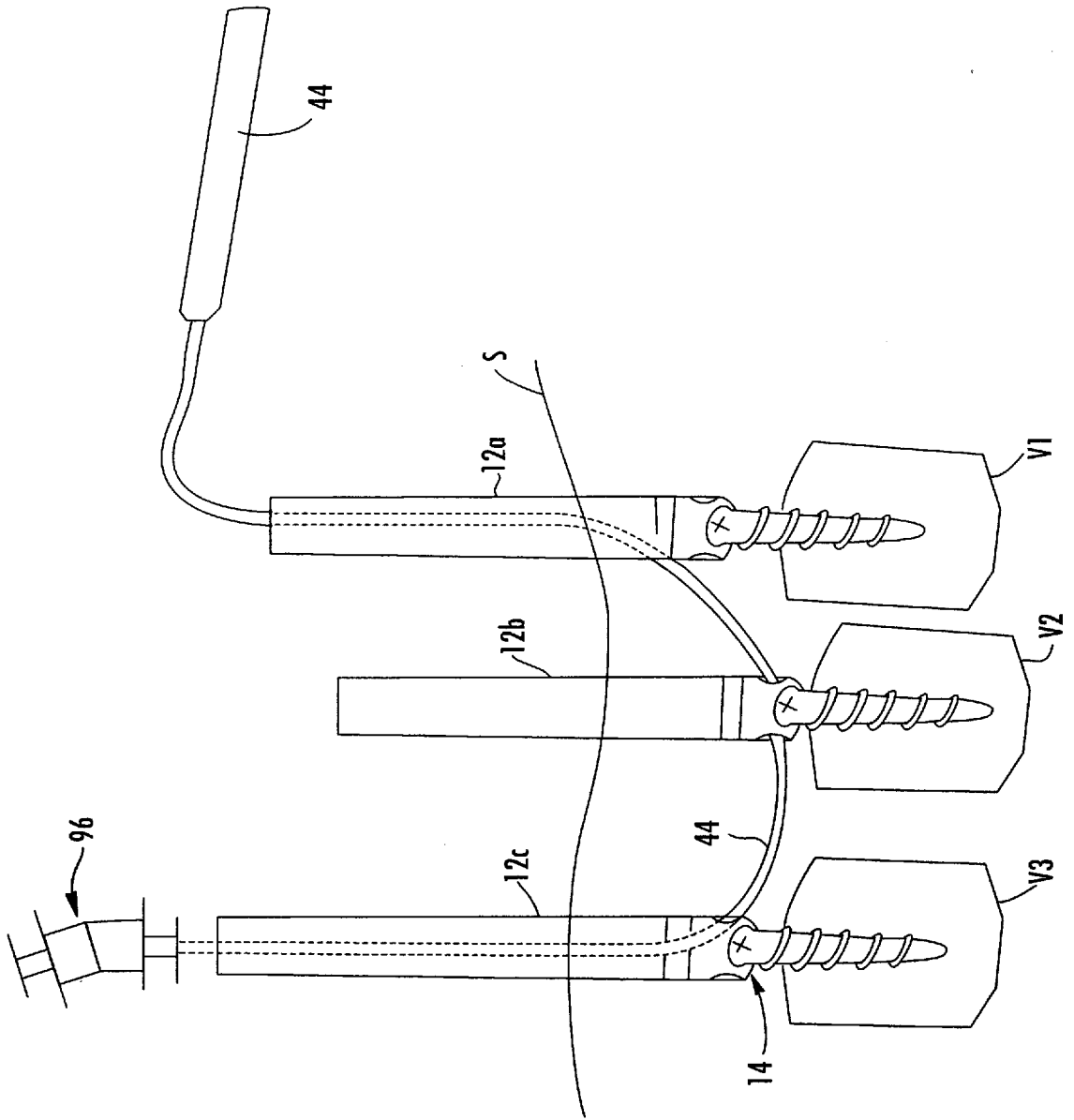
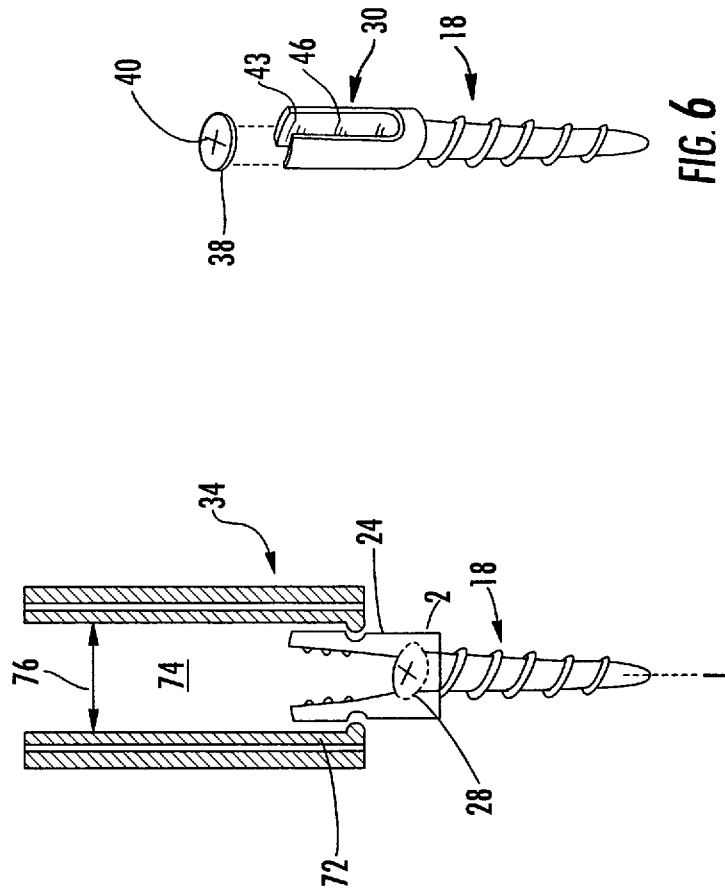

FIG. 4



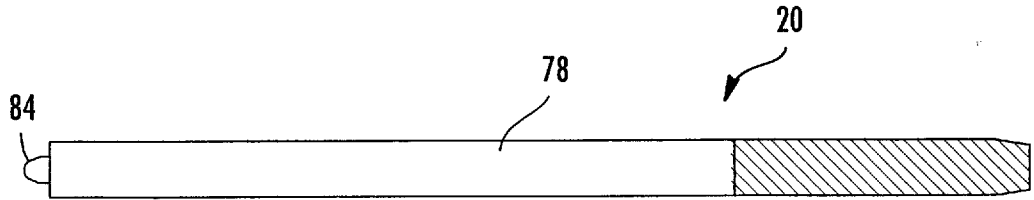

FIG. 7a

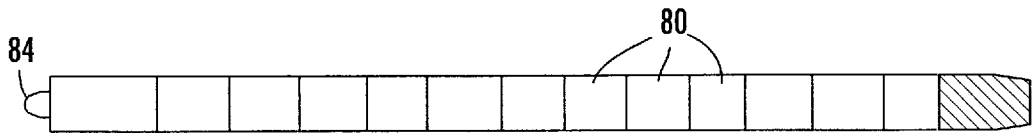

FIG. 7b

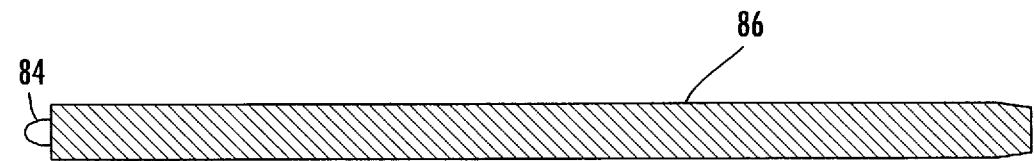

FIG. 7c

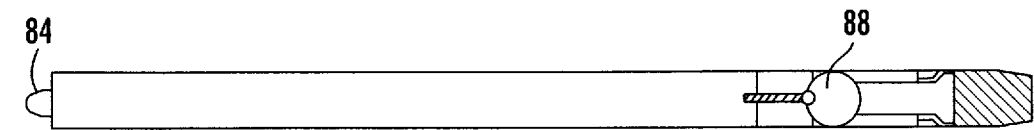

FIG. 7d

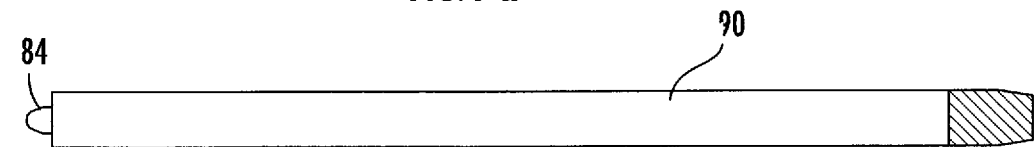

FIG. 7e

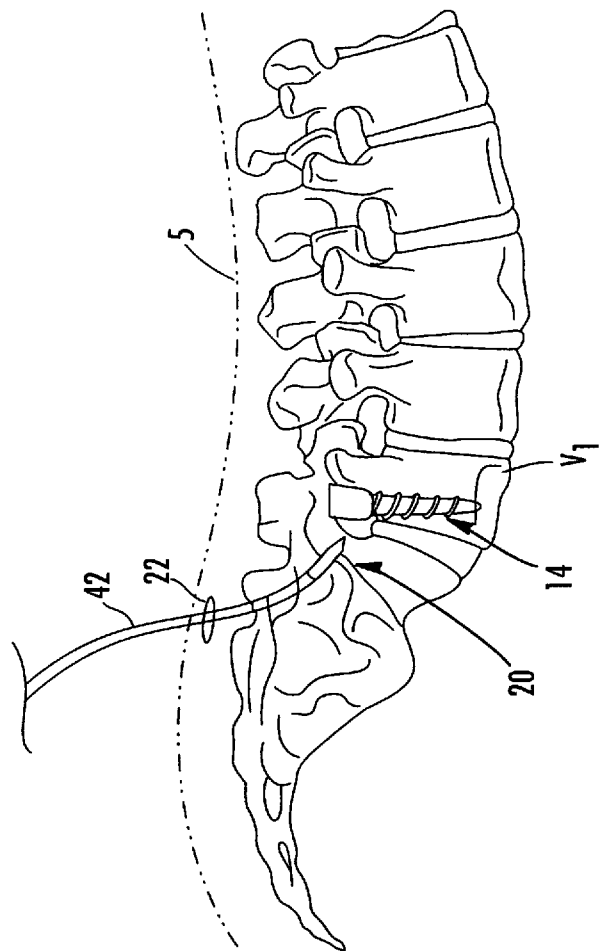
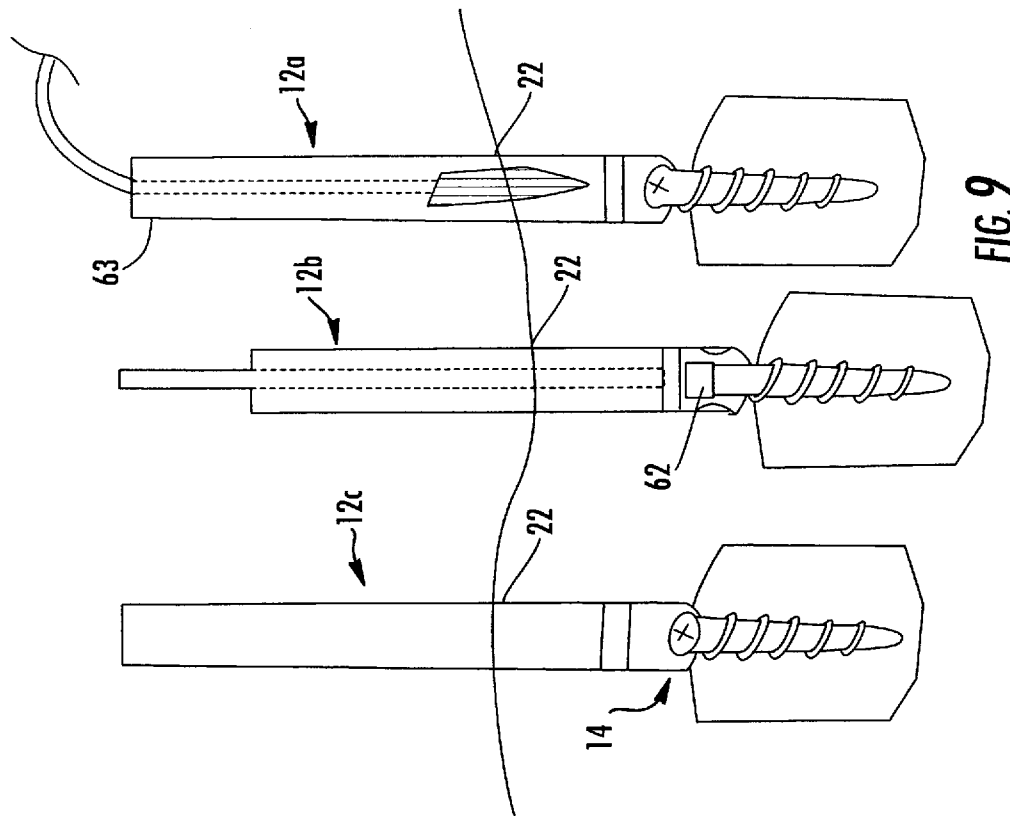

FIG. 8



**INTERNATIONAL SEARCH REPORT**

International application No.  
PCT/US 08/54544

<b>A. CLASSIFICATION OF SUBJECT MATTER</b> IPC(8) - A61B 17/88; A61B 17/16 (2008.04) USPC - 600/424 According to International Patent Classification (IPC) or to both national classification and IPC		
<b>B. FIELDS SEARCHED</b> Minimum documentation searched (classification system followed by classification symbols) IPC(8): A61B 17/88; A61B 17/16 (2008.04) USPC: 600/424 Documentation searched other than minimum documentation to the extent that such documents are included in the fields searched IPC(8): A61B 17/88; A61B 17/16 (2008.04) USPC: 600/424 Electronic data base consulted during the international search (name of data base and, where practicable, search terms used) USPTO WEST (USPT, PGPUB, EPAB, JPAB); anchor\$, plurality, multiple, magnet\$, biocompatible, target\$, steer\$, navigat\$, catheter, force, sens\$, feedback, anchor, fasten\$, bone, bony Google Scholar; 'magnetic targeting system catheter'		
<b>C. DOCUMENTS CONSIDERED TO BE RELEVANT</b>		
Category*	Citation of document, with indication, where appropriate, of the relevant passages	Relevant to claim No.
X --- Y	US 2005/0055089 A1 (MACOVIAK, et al.) 10 March 2005 (10.03.2005), para[0106], [0148], [0151], [0152], Figs. 26B, 27B, 27C	1, 3, 6-8, 10, 11, 13, 16-18, 20 ----- 2, 4, 5, 9, 12, 14, 15, 19
Y	US 2006/0149135 A1 (PAZ) 06 July 2006 (06.07.2006), para[0017], [0098], claim 32	2, 5, 12, 15
Y	US 2003/0065373 A1 (LOVETT, et al.) 03 April 2003 (03.04.2003), para[0070]	4, 14
Y	US 2008/0039845 A1 (BONUTTI) 14 February 2008 (14.02.2008), para[0363]	9, 19
<input type="checkbox"/> Further documents are listed in the continuation of Box C. <input type="checkbox"/>		
* Special categories of cited documents: "A" document defining the general state of the art which is not considered to be of particular relevance "E" earlier application or patent but published on or after the international filing date "L" document which may throw doubts on priority claim(s) or which is cited to establish the publication date of another citation or other special reason (as specified) "O" document referring to an oral disclosure, use, exhibition or other means "P" document published prior to the international filing date but later than the priority date claimed "T" later document published after the international filing date or priority date and not in conflict with the application but cited to understand the principle or theory underlying the invention "X" document of particular relevance; the claimed invention cannot be considered novel or cannot be considered to involve an inventive step when the document is taken alone "Y" document of particular relevance; the claimed invention cannot be considered to involve an inventive step when the document is combined with one or more other such documents, such combination being obvious to a person skilled in the art "&" document member of the same patent family		
Date of the actual completion of the international search 07 July 2008 (07.07.2008)		Date of mailing of the international search report <p align="center" style="font-size: 1.2em;"><b>14 JUL 2008</b></p>
Name and mailing address of the ISA/US Mail Stop PCT, Attn: ISA/US, Commissioner for Patents P.O. Box 1450, Alexandria, Virginia 22313-1450 Facsimile No. 571-273-3201		Authorized officer: <p align="center">Lee W. Young</p> PCT Helpdesk: 571-272-4300 PCT OSP: 571-272-7774