

(19)
(12)

(KR)
(Y1)

(51) 。 Int. Cl. ⁷
E01D 19/04

(45) 2001 10 08
(11) 20 - 0242583
(24) 2001 08 01

(21) 20 - 2001 - 0008053
(22) 2001 03 23

(73) 7336 - 3

(72) () 803 1104
217 - 132 105 501

(74)
:
가 :

(54)

가 , 4
(5) (10), (10)
1 2 (30a, 30b), 1 (30a) 2 (30b)
(40), ' ' (55a)
(50a), ' ' (55b)
(50b), (55a) (55b)
(50a) (50b) (60), (50b)
(70)

1

2

3

<

10 : 20 :

30a : 1 30b : 2

40 : 50a :

50b : 60 :

70 :

가

가

가

가

가

1

, 2

가, , 4
 (5) 1 (30a) 2 (10), (10) 1 2
 (30a, 30b), (30a) 2 (30b) (40), ' ' (50a), '
 (55a) (55b) (50a), '
 50b), (55a) (55b) (50a)
 (50b) (60), (50b)
 (70)

(50a) (40)가 ' ' .
 (10) (50a)가 (10) (15b) (15b) ()
 15b) 가 (50a)가 , ' ' (15b)

1 2 (30a, 30b) , 1 (30a) , 1 (30
 a) (20) .
 (50b) (75a)가 (70)
 (75b) , (75a) (75b) (50b)
 (70)

(10) (5) (10)
 (20) 1 (30a) , 1 (30a)
 (40) 1 (30a) 가 (40)가 ,
 (40)가 (40)가

(40)가 2 (30b) (40) , 2
 (30b) (50a) 1 2 (30b) (40)
 (50a)

(50a) (55a) , ' '
 (50b) (55b) (60)
 (55a) (55b) (60)

(60) (50a) (50b)가 (60)
 (60) (65)가 (60) .
 (50b) (70) , (70)

3
 (100) 가

가 , (100) (60)

A 가 (40)가

가 ,
가

(57)

1.

1 2 (5) (10), (10) , 4
 (40), ' ' (30a, 30b), 1 (30a) 2 (30b) (55a)
 (50a), ' ' (55a) (55b)
 (50a) (50b), (55b) (60), (50b)
 (70)

2.

1 , (50a) (40)가 ' '

3.

1 , (50a) (55a) (60)

4.

1 , (50b) (55b) (60)

5.

1 , (50b) (75a)가

6.

1 , (70) (75b)

1

100

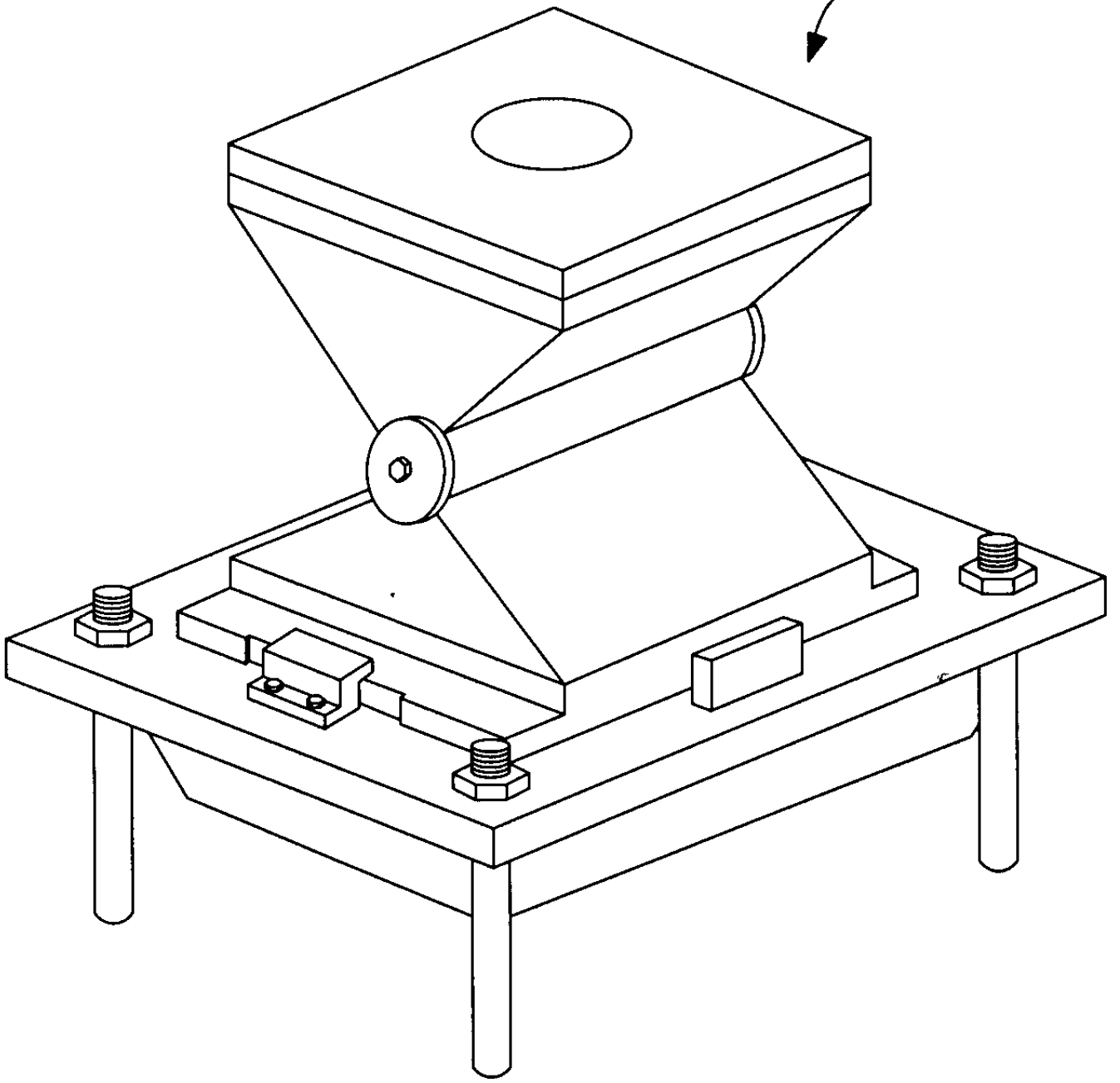

2

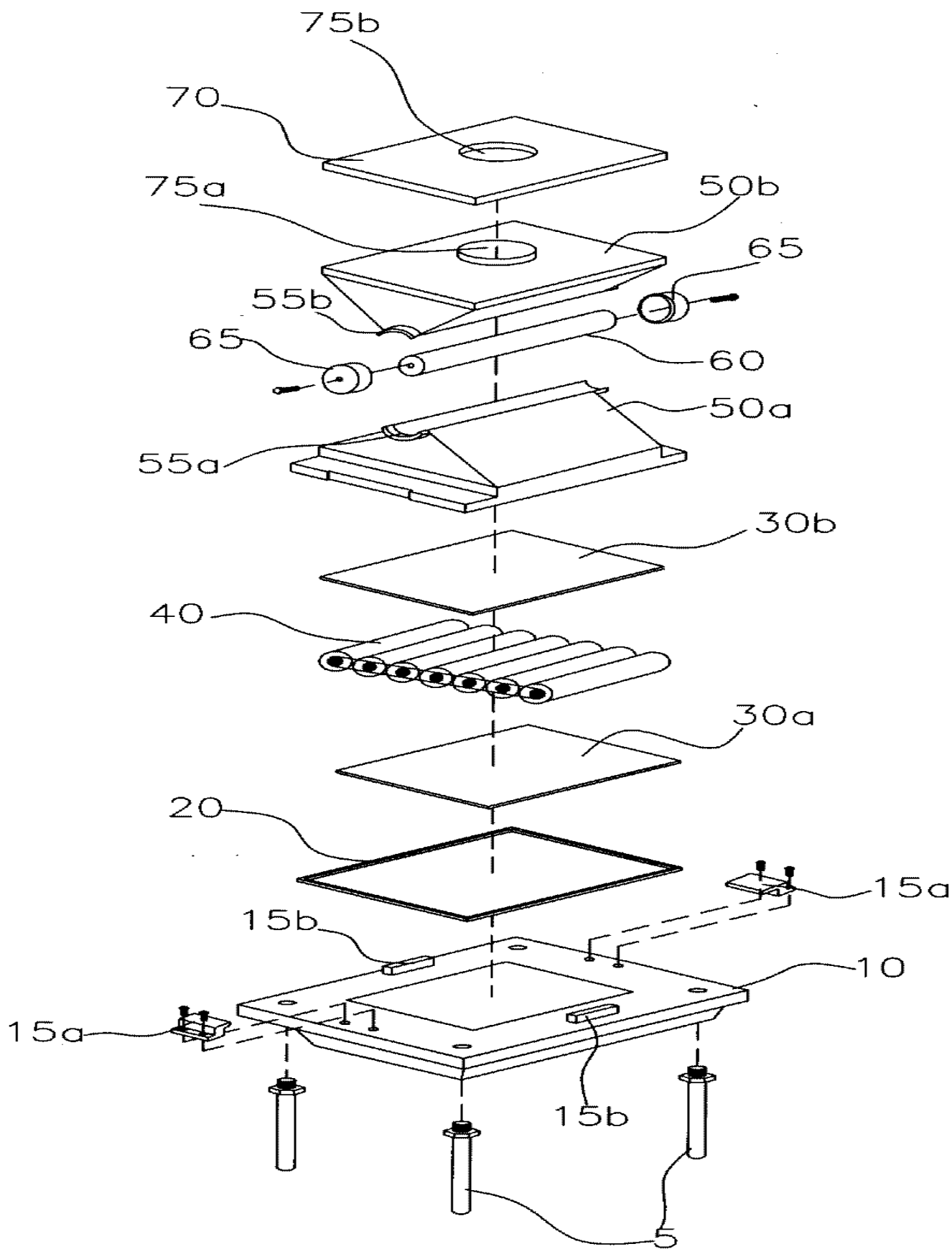

3

