

(19) World Intellectual Property
Organization
International Bureau



(43) International Publication Date
3 November 2005 (03.11.2005)

PCT

(10) International Publication Number
WO 2005/102234 A2

(51) International Patent Classification⁷: **A61F 13/00**

(21) International Application Number:
PCT/US2005/008129

(22) International Filing Date: 10 March 2005 (10.03.2005)

(25) Filing Language: English

(26) Publication Language: English

(30) Priority Data:
60/561,745 13 April 2004 (13.04.2004) US
10/982,346 5 November 2004 (05.11.2004) US

(71) Applicant (for all designated States except US):
BOEHRINGER LABORATORIES, INC. [US/US];
P.O. Box 870, Norristown, PA 19404 (US).

(72) Inventors; and

(75) Inventors/Applicants (for US only): **BOEHRINGER, John, R.** [US/US]; 427 Parkview Drive, Wynnewood, PA 19096 (US). **KARPOWICZ, John** [US/US]; 1435 Yellow

Springs Road, Chester Springs, PA 19425 (US). **MITRA, Amitabha** [US/US]; 66 Battery Hill Road, Voorhees, NJ 08043 (US). **RADL, Christopher, L.** [US/US]; 530 Clothier Springs Road, Malvern, PA 19355 (US).

(74) Agent: **ETKOWICZ, Jacques, L.**; RatnerPrestia, P.O. Box 980, Valley Forge, PA 19482 (US).

(81) Designated States (unless otherwise indicated, for every kind of national protection available): AE, AG, AL, AM, AT, AU, AZ, BA, BB, BG, BR, BW, BY, BZ, CA, CH, CN, CO, CR, CU, CZ, DE, DK, DM, DZ, EC, EE, EG, ES, FI, GB, GD, GE, GH, GM, HR, HU, ID, IL, IN, IS, JP, KE, KG, KP, KR, KZ, LC, LK, LR, LS, LT, LU, LV, MA, MD, MG, MK, MN, MW, MX, MZ, NA, NI, NO, NZ, OM, PG, PH, PL, PT, RO, RU, SC, SD, SE, SG, SK, SL, SM, SY, TJ, TM, TN, TR, TT, TZ, UA, UG, US, UZ, VC, VN, YU, ZA, ZM, ZW.

(84) Designated States (unless otherwise indicated, for every kind of regional protection available): ARIPO (BW, GH, GM, KE, LS, MW, MZ, NA, SD, SL, SZ, TZ, UG, ZM, ZW), Eurasian (AM, AZ, BY, KG, KZ, MD, RU, TJ, TM),

[Continued on next page]

(54) Title: WOUND CONTACT DEVICE

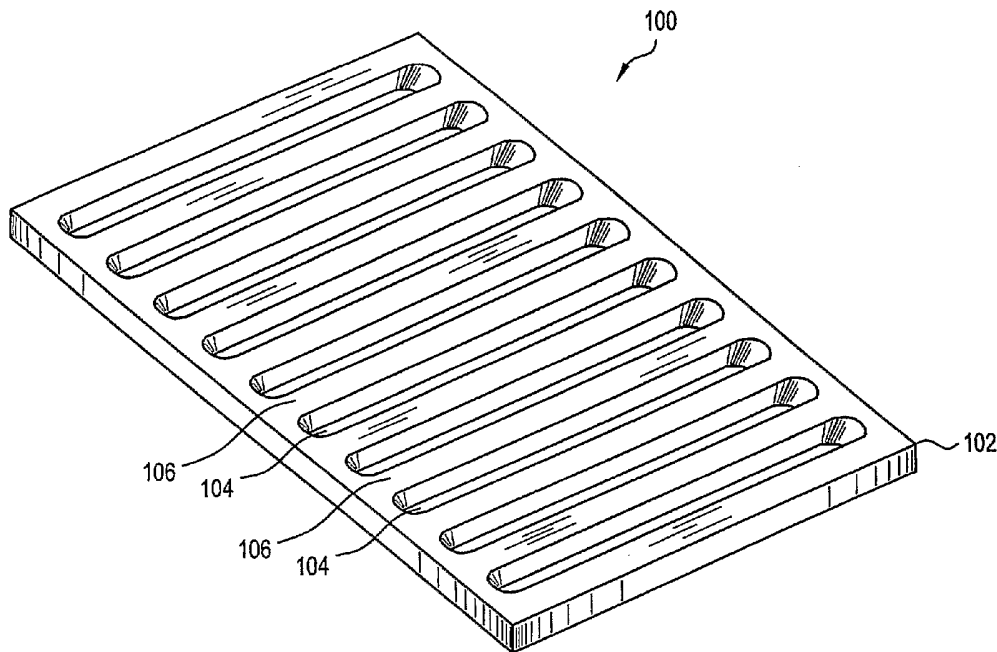

(57) Abstract: A therapeutic device for promoting the healing of a wound in a mammal is disclosed. An exemplary device comprises a permeable structure having a plurality of depressions formed in a surface thereof. In use, the surface having the depressions is disposed adjacent a surface of the wound. A method of treating a wound comprises the steps of providing a permeable structure comprising a plurality of randomly disposed fibers and having i) a plurality of wound surface contact elements disposed between end portions of the structure, and ii) a plurality of voids defined by the contact elements; and applying the permeable structure to at least one surface of the wound.

WO 2005/102234 A2



European (AT, BE, BG, CH, CY, CZ, DE, DK, EE, ES, FI, FR, GB, GR, HU, IE, IS, IT, LT, LU, MC, NL, PL, PT, RO, SE, SI, SK, TR), OAPI (BF, BJ, CF, CG, CI, CM, GA, GN, GQ, GW, ML, MR, NE, SN, TD, TG).

For two-letter codes and other abbreviations, refer to the "Guidance Notes on Codes and Abbreviations" appearing at the beginning of each regular issue of the PCT Gazette.

Published:

— *without international search report and to be republished upon receipt of that report*

- 1 -

WOUND CONTACT DEVICE

CROSS REFERENCE TO RELATED APPLICATIONS

This application claims the benefit of priority to U.S. Provisional Patent Application Number 60/561,745, filed on April 13, 2004, the contents of which are
5. incorporated in this application by reference.

FIELD OF THE INVENTION

The invention relates to a device and method for treating wounds. More specifically, the present invention relates to a therapeutic wound contact device.

BACKGROUND OF THE INVENTION

10 Wound healing is a basic reparative process of the human body. It has been known throughout time that dressing wounds with appropriate materials aids the body's natural regenerative process. Historically, such materials have been made from cotton fibers; e.g. gauze. These dressings are beneficial to the healing process because they insulate damaged tissue from external contaminants and because they remove
15 potentially deleterious wound exudates.

Numerous studies suggest that wound healing depends on the interplay of complex mechanisms involving cell proliferation, migration and adhesion coupled with angiogenesis. Application of traditional gauze or other essentially flat materials are essentially sub-optimal with respect to these mechanisms. Wound healing studies In-
20 vitro are carried out in cell culture vehicles that permit cellular function. It is therefore desirable in the practice of wound healing to provide the equivalent of cell culture or a bioreactor system to allow the optimal interplay of cell functions of proliferation, migration and adhesion. Additionally, it is essential to incorporate other bodily functions that encourage the supply of fibronectins, plasma proteins, oxygen, platelets,
25 growth factors, immunochemicals and so forth.

As science and medicine have advanced, the technology incorporated into wound healing devices has improved substantially. Highly absorbent wound dressings capable of absorbing many times their weight in liquids are available. Systems that temporarily seal wounds and utilize suction to remove exudates have found widespread
30 utilization. Dressings incorporating anti-microbial agents and biologic healing agents are common. Devices that provide a moist wound environment for improved healing have been found to be useful.

- 2 -

In spite of the technological gains in wound healing devices and dressings, millions of people still suffer from chronic wounds. Such chronic wounds are debilitating and can last for years, greatly diminishing the individual's quality of life. Often such wounds result in the loss of a limb. Individuals may even die from complications such as infection.

As such, there is a dire need for more effective wound healing devices and methods.

SUMMARY OF THE INVENTION

To provide for improved wound healing, the present invention is a wound contact material, a method for making the wound contact material, and a method of treatment employing the wound contact material.

According to an exemplary embodiment of the present invention, a therapeutic device for promoting the healing of a wound in a mammal is provided. The device comprises a permeable substrate or structure having a plurality of depressions formed in a surface thereof, wherein said surface having said depressions is disposed in surface contact with the wound.

According to a further exemplary embodiment of the present invention, a therapeutic device for promoting the healing of a wound in a mammal is provided. The device comprises a permeable structure having a plurality of wound surface contact elements disposed between end portions of the structure, and a plurality of voids defined by the contact elements.

According to an additional exemplary embodiment of the present invention, a therapeutic device for promoting the healing of a wound in a mammal, the device comprising a permeable structure comprising a plurality of fibers coupled to one another having a plurality of wound surface contact elements disposed between end portions of the structure and a plurality of voids defined by the contact elements is provided.

According to a yet further exemplary embodiment of the present invention, a therapeutic device for promoting the healing of a wound in a mammal, the device comprising a polyester felt having a plurality of wound surface contact elements disposed between end portions of the structure and a plurality of voids defined by the contact elements is provided.

According to an additional exemplary embodiment of the present invention, a method of manufacturing a therapeutic device for promoting the healing of a wound in

- 3 -

a mammal comprises the steps of providing a molten substrate material providing a mold defining a plurality of depressions and a plurality of contact elements and applying the molten substrate material to the mold.

According to an even further exemplary embodiment of the present invention, a method of manufacturing a therapeutic device for promoting the healing of a wound in a mammal comprises the steps of providing a permeable structure and forming a plurality of depressions into a surface of the permeable structure.

According to another exemplary embodiment of the present invention, a method of treating a wound comprises the steps of providing a permeable structure comprising i) a plurality of wound surface contact elements disposed between end portions of the structure, and ii) a plurality of voids defined by the contact elements, and applying the permeable structure to at least one surface of the wound and applying a force to the structure to maintain the structure in intimate contact with the wound surface .

These and other aspects and objects will become apparent from the following description.

BRIEF DESCRIPTION OF THE DRAWINGS

The invention is best understood from the following detailed description when read in connection with the accompanying drawings. It is emphasized that, according to common practice, the various features of the drawings are not to scale. On the contrary, the dimensions of the various features are arbitrarily expanded or reduced for clarity. Included in the drawings are the following Figures:

Figure 1 is a perspective view of a channeled wound contact dressing according to a first exemplary embodiment of the present invention;

Figure 2A is a perspective view of a channeled wound contact composite according to a second exemplary embodiment of the present invention;

Figure 2B is a cross section of the channeled wound contact composite according to the second exemplary embodiment of Figure 2A;

Figure 3A is a perspective view of a dimpled wound dressing according to a third exemplary embodiment of the present invention;

Figure 3B is a top view of the dimpled wound dressing illustrated in Figure 3A;

Figure 3C is a bottom view of the dimpled wound dressing illustrated in Figure 3A;

- 4 -

Figure 3D is a cross sectional view of the dimpled wound dressing illustrated in Figure 3A;

Figures 4A, 4B, 4C are illustrations of the dimpled wound dressing of Figure 3A in use;

5 Figure 5A is a perspective view of an irregular wound contact dressing according to a fourth exemplary embodiment of the present invention;

Figure 5B is a cross sectional view of the irregular wound contact dressing illustrated in Figure 5A.

DETAILED DESCRIPTION OF THE INVENTION

10 A wound dressing with a discontinuous contact layer surface has the advantages of promoting tissue growth with wound surface contact elements and permitting tissue growth by providing void volume for the subsequent tissue growth within the discontinuities. Desirably, the structure of the contact material is sufficiently physically rugged to resist flattening when forces required to press the material against
15 the wound surface are applied to the material.

It is desirable for the material to retain its structure when exposed to aqueous or other bodily fluids. Many traditional dressing materials soften as they moisten so that their geometry changes. The contact layer is permeable, permitting the underlying wound to breathe and allowing for fluids to be drawn from the wound. The contact
20 layer should not be too absorbent as this might result in a loss of structure. The layer is comprised of base materials that are resistant to change in the presence of moisture and aqueous liquids.

In the current embodiment, the extent of the voids remaining above the wound surface is preferably at least 0.1 mm when the structure is pressed against the surface
25 of the wound. The width of the voids, as defined by contact elements adjacent the voids, is preferably greater than 0.1 mm. A more preferred width is between about .5 to 10 mm and a more preferred height is between about .2 to 5 mm.

Wound healing is recognized as a complex process. When a wound contact material as described is forced against a wound surface, a number of biological
30 processes are believed to occur. Mechanical stress is applied to the underlying tissue. The discontinuities in the contact surface impose a force resulting in a catenary shape on the tissue. These mechanical forces encourage cellular activities as well as angiogenesis, and the discontinuities begin to fill with granular tissue. Excess fluid is conveyed away from the wound and tissue develops in a manner and pattern whereby

disruption of the newly developed tissue is minimized upon removal of the contact surface.

A fibrous substrate or structure has all the flexibilities provided by the textile arts. Fibrous textiles can be formed into a structure for the invention by a number of the methods known in the art. Among these methods are knitting, weaving, 5 embroidering, braiding, felting, spunbonding, meltblowing, and meltspinning. Each of these methods can be further adapted to produce a material whose structure matches that of the present invention. The desired structure can be imparted during production of the structure by, for example, applying molten material directly to a mold as in 10 meltblowing. Alternatively, the structure can be formed by working a formed structure after production by, for example, heat stamping or vacuum forming. Further, fibers can be mixed with an adhesive and sprayed onto a textured surface.

The versatility of fibrous textiles also extends to their easy adaptation to composite applications. Individual fiber materials may be varied to optimize a physical 15 parameter such as rigidity or flexibility. Individual fiber materials can also be selected for their known ability to assist in wound healing. Examples of such fiber materials are calcium alginate, and collagen. Alternatively, fibers may be treated with known wound healing agents such as hyaluronic acid or antimicrobial silver. The ratio of the fiber materials can be varied to suit the requirements of the wound. According to one 20 desirable aspect of the invention, different fibers with various wound healing properties may be added as desired.

Other fibrous structures that are anticipated as beneficial additions include:

1. Fluid absorbing fibers
2. Non-adsorbent fibers
- 25 3. Bio-absorbable fibers
4. Wicking fibers to wick fluid away from the surface of the wound
5. Fibers with known healing effects, such as calcium alginate
6. Bio-erodable fibers for the controlled release of a curative agent
7. Conductive fibers for the delivery of an electric charge or current
- 30 8. Adherent fibers for the selective removal of undesirable tissues, substances or microorganisms
9. Non-adherent fibers for the protection of delicate tissue

- 6 -

An exemplary embodiment of the present invention is illustrated in Figure 1. As shown in Figure 1, channeled wound dressing 100 is comprised of a generally conformable polyester felt material 102. An alternative polyester textile such as a knit, weave, or braid may also be suitable for most applications. Polyolefins, such as polyethylene or polypropylene, and polyamides, such as nylon, with similar physical properties are also contemplated. Creep resistance, as exhibited by polyester, is particularly desirable. Void channels 104 are cut into felt material 102 to provide a discontinuity that promotes the upward growth of new tissue. In use, the channeled wound dressing 100 is pressed against a wound in intimate contact with injured tissue. A force of 0.1 psi or more is desirably applied to the contact layer to press the contact elements against the surface of the wound. Wound contact elements 106 are thus in intimate contact with injured tissue.

Figures 2A and 2B illustrate a wound dressing composite 200 comprised of channeled dressing 100 and a vapor permeable adhesive backed sheet 202. Adhesive backed vapor permeable sheets, in general, are known in the art and are believed to contribute to wound healing by maintaining a moisture level that is optimal for some wounds. In use, dressing composite 200 is placed onto the surface of the wound with its channeled dressing 100 portion in contact with the wound. Adhesive sheet 202 covers channeled dressing 100 and adheres to skin adjacent the wound. Composite 200 offers the advantages of channeled dressing 100. Additionally, adhesive sheet 202 secures composite 200 and protects the wound from bacteria, etc. while allowing for the transmission of moisture vapor.

Another desirable embodiment of the present invention is illustrated in Figures 3A, 3B, 3C, and 3D. The substrate or structure for dimpled wound dressing 300 can be constructed from similar materials and production methods employed for channeled dressing 100. Fig 3A depicts a perspective view of dimpled dressing 300 with contact surface 320 on top. Figure 3D shows a cross section of the dimpled dressing 300 which best illustrates the plurality of contact elements 322 and dimple voids 330. Preferably, the total dimple void area comprises at least about 25% of the total dressing area. More preferably, the total dimple void area comprises at least about 50% of the total dressing area. Dimple voids 330 are partially defined by sidewalls 332. Sidewalls 332 are partially responsible for providing rigidity necessary to resist compaction of dimple dressing 300. Contact elements are preferably constructed to provide an arcuate contact surface. In a preferred embodiment, the radius of contact is between about 0.1 mm to 1 mm.

- 7 -

Dimple voids 330 can be formed in a variety of regular or irregular shapes. Preferably, dimple voids are constructed so that they are not "undercut" such that each aperture circumference is smaller than the corresponding inner void circumference. An "undercut" or reticulated void structure can cause tissue disruption when the dressing
5 300 is removed because any tissue that has grown into the void may be torn away when the material is removed from the wound. Additionally, undercut or reticulated void structures are more likely to result in shedding of the dressing material into the newly developing wound tissue.

In one preferred embodiment, a base material for dressing 300 is Masterflo RTM
10 from manufactured by BBA group of Wakefield, MA. In this exemplary embodiment, the base material has a thickness of about 1.0 mm. Dimple voids 330 are heat stamped in to the base material having a depth of about .75 mm and a diameter of about 2 mm.

Because the contact layer is generally replaced every few days it is important to account for the possibility of alignment of newly formed tissue with the voids of a new
15 contact layer. Thus, according to exemplary embodiments of the present invention 1) dimple voids 330 can be arranged randomly so that they don't line up with the new tissue growth after each dressing change, 2) different contact layers with different diameter dimples may be provided, or 3) a different spacing of the dimples can be used every time the material is changed.

20 Figures 3B and 3C illustrate the corresponding top and bottom views, respectively, of dimpled dressing 300. One variation of this embodiment is also contemplated having dimple voids 330 and/or contact elements 322 disposed on both the top and bottom of dimpled dressing 300. A second variation on dimpled wound dressing 300 is also contemplated wherein some or all of the dimple voids 330 are
25 replaced with holes traversing the structure's entire thickness such that the top and bottom views of the variation would appear similar to Figure 3B.

In one exemplary embodiment, dimple voids 330 can be partially filled with therapeutic substances. For example, antiseptic substances might be placed in voids
30 330 for treating infected wounds. Further, biologic healing agents could be delivered in the voids to improve the rate of new tissue formation. In yet another exemplary embodiment, the layer of dressing 300 could have a different function on each side. For example, one side of dressing 300 could be optimized for the growth of new tissue, while the other side could be optimized for the delivery of anti-microbial agents, for example.

- 8 -

Use of dimpled dressing 300 is illustrated by Figures 4A, 4B, and 4C. Figure 4A shows a wound surface 400. Note that wound surface 400 may represent the majority of a shallow surface wound or a small interior portion of a deep tissue wound. Figure 4B shows application of dimpled dressing 300 to wound surface 400 and corresponding tissue growth 410 within dimple voids 330. Finally, removal of dimpled dressing 300 leaving tissue growth 410 is illustrated in Figure 4C. As will be addressed in detail below, it is desirable to provide an external force for keeping dressing 300 pressed against the surface of the wound.

Figures 5A and 5B illustrate another embodiment of the present invention; a rough irregular dressing 500. From a perspective view, Figure 5A depicts how irregular dressing 500 has irregular voids 510 and irregular contact elements 520 acting as "hook-like" members that are able to contact and stick to necrotic tissue when the substrate is placed in the wound. When the substrate is removed from the wound, necrotic tissue is stuck to hook like protrusions 520 and is thus removed from the wound. Removal of the substrate debrides the wound. Removal of necrotic tissue is an important part of healing wounds. The substrate of dressing 500 may be made from polyester felt or batting. In one exemplary embodiment, the felt is singed with hot air so that a percentage of the fibers melt to form a textured surface with a number of hook like elements 520. Another suitable configuration can be the hook material such as that used with hook and loop fabric.

After adequate removal of the necrotic tissue, the wound may still be considered infected and can be treated with the substrate including antimicrobial silver, for example, which is useful in killing bacteria, while the substrate and method of use facilitate the growth of new tissue.

The phase of wound healing where new tissue is forming is generally referred to as the proliferative phase. Once the wound is adequately healed in the proliferative phase and the bacterial load is adequately reduced, a substrate without antimicrobial silver and optionally with the addition of growth enhancing materials is used to facilitate the continued proliferation of new cells and tissue.

Figure 5B shows the random cross section of irregular dressing 500. The roughened surface of irregular dressing 500 can be formed by passing a suitable substrate under convective heat at or about the melting point of the substrate's component material. For example, polyester materials typically melt in a range from about 250 degrees Celsius to about 290 degrees Celsius. A polyester felt material passed briefly under a convective heat source operating in this range will experience surface melting and subsequent fusing of the polyester strands at its surface. The

- 9 -

degree of surface melting can be controlled with temperature and exposure time to yield a surface of desired roughness exhibiting irregular voids 510 and irregular contact elements. Although irregular dressing 500 is illustrated as having only one roughened surface the invention is not so limited in that both upper and lower surfaces may be similarly roughened. Such a dressing would be useful in the treatment of an undermined wound.

As described above, treatment with the present wound dressing invention comprises forcing the inventive dressing into intimate contact with the wound surface. Generally the force should be at least 0.1 psi. Various methods and systems for maintaining this intimate contact are contemplated. These methods and systems may include: applying an adhesive film over the inventive dressing and adjacent the wound surface; wrapping a bandage over the dressing and around the injured area; and securing a balloon or other inflatable bladder to the structure and inflating the bladder with air or a liquid. In one exemplary embodiment, the application of pressure to the bladder is provided intermittently. A conformable seal may be placed over the wound and contact structure, a rigid seal is then secured over the wound, contact structure imparting a force on the contact structure. A pressure is then applied between the rigid seal and the flexible seal forcing the contact structure against the wound surface. The intimate contact may be augmented by sealing the wound area with a conformable cover and applying suction. When suction is used, dimpled wound dressing 300 is particularly well-adapted for this application. In general the range of suction levels is between .25 PSI and 5 psi. The suction use can be further improved by applying a wound packing material to the back of the dressing. One such suitable wound packing material is described in U.S. Provisional Patent Application Number 60/554,158, filed on March 18, 2004.

Case Study 1

Patient A is a 70 year old male with a Stage IV decubitus ulcer on the right hip with significant undermining. The contact structure of the present invention was applied to the wound and an adhesive film was placed over the wound and the contact structure. A suction of 1.1 psi was applied beneath the adhesive film to impart a force upon the contact structure. The suction was maintained generally continuously. The contact material was replaced every two to four days. After use of the device for 30 days the undermined portion of the wound had virtually healed and the area of the wound opening had decreased from 66 square cm to 45 square cm. A split thickness skin graft was applied to the wound.

- 10 -

Case study 2

Patient B is a 50 year old male with a fracture of the right ankle with exposed bone. A plate was used to reduce the fracture and a rectus abdominus free flap was performed to cover the exposed bone and hardware. The flap only partially
5 survived resulting in an open wound with exposed bone and hardware. The contact structure of the present invention was applied to the wound and an adhesive film was placed over the wound and the contact structure. A force was applied to the contact structure by the application of an ace bandage wrapped around the ankle or by the application of suction. The suction force was generally applied for about half of the day
10 and the force of the bandage wrap was maintained for the remainder of the day. For a number of days, the bandage wrap was solely used to impart the force. When the force was imparted by suction a suction of between 1 and 2 psi was used. In less than 2 weeks new tissue had grown over the exposed hardware. In a period of 7 weeks the wound area was reduced from to 50 square cm to 28 square cm.

15 While preferred embodiments of the invention have been shown and described herein, it will be understood that such embodiments are provided by way of example only. Numerous variations, changes, and substitutions will occur to those skilled in the art without departing from the spirit of the invention. Accordingly, it is intended that the appended claims cover all such variations as fall within the spirit and scope of the
20 invention.

What is Claimed:

- 1 1. A therapeutic device for promoting the healing of a wound in a mammal, said
2 device comprising:
 - 3 a permeable structure having a plurality of depressions formed in a surface
4 thereof,
5 wherein said surface having said plurality of depressions is disposed in contact
6 with at least one surface of the wound, and said structure substantially maintains a
7 predetermined configuration at least in the presence of fluids within the wound.
- 1 2. The device of claim 1 wherein the structure comprises a synthetic polymer.
- 1 3. The device of claim 2 wherein the synthetic polymer comprises a polyolefin.
- 1 4. The device of claim 3 wherein the polyolefin is one of polyethylene or
2 polypropylene.
- 1 5. The device of claim 2 wherein the synthetic polymer comprises a polyamide.
- 1 6. The device of claim 4 wherein the polyamide is nylon.
- 1 7. The device of claim 2 wherein the synthetic polymer comprises a polyester.
- 1 8. The device of claim 1 wherein the structure comprises a woven material.
- 1 9. The device of claim 1 wherein the structure comprises a knit material.
- 1 10. The device of claim 1 wherein the structure comprises an braided material.
- 1 11. The device of claim 1 wherein the structure comprises an embroidered material.
- 1 12. The device of claim 1 wherein the structure comprises a felt material.
- 1 13. The device of claim 1 wherein the structure comprises a spunbonded material.
- 1 14. The device of claim 1 wherein the structure comprises a meltblown material.
- 1 15. The device of claim 1 wherein the structure comprises a meltspun material.
- 1 16. The device of claim 1 wherein the structure comprises a fibrous material
2 comprising at least one fiber.
- 1 17. The device of claim 16 wherein the fiber further comprises a healing agent.
- 1 18. The device of claim 17 wherein the healing agent is at least one of hyaluronic
2 acid and/or antimicrobial silver.
- 1 19. The device of claim 16 further comprising a second fiber comprising a healing
2 material selected from the group consisting of collagen and calcium alginate.

1 20. The device of claim 1 further comprising an adhesive film coupled to at least a
2 portion of the permeable structure.

1 21. A therapeutic device for promoting the healing of a wound in a mammal, said
2 device comprising:

3 a permeable structure having:

4 a plurality of wound surface contact elements disposed between end
5 portions of the structure; and

6 a plurality of voids defined by the contact elements,

7 wherein said structure substantially maintains a predetermined
8 configuration at least in the presence of fluids within the wound.

1 22. The device of claim 21 wherein the structure further comprises a first side
2 having a first surface area and a second side having a second surface area.

1 23. The device of claim 22 wherein the plurality of the voids are disposed on at least
2 one of said first side and/or said second side.

1 24. The device of claim 23 wherein the plurality of voids occupy more than about
2 25% of the surface area of the side in which they are disposed.

1 25. The device of claim 23 wherein the plurality of voids occupy more than about
2 50% of the surface area of the side in which they are disposed.

1 26. A therapeutic device for promoting the healing of a wound in a mammal, said
2 device comprising:

3 a permeable structure comprising a plurality of randomly disposed fibers coupled
4 to one another and having:

5 a plurality of wound surface contact elements disposed between end
6 portions of the structure; and

7 a plurality of voids defined by the contact elements.

1 27. A therapeutic device for promoting the healing of a wound in a mammal, said
2 device comprising:

3 a polyester felt having a plurality of wound surface contact elements disposed
4 between end portions of the structure; and

5 a plurality of voids defined by the contact elements.

1 28. A method of manufacturing a therapeutic device for promoting the healing of a
2 wound in a mammal comprising the steps of:

3 providing a molten substrate material;

4 providing a mold defining a plurality of depressions and a plurality of contact
5 elements;

6 applying the molten substrate material to the mold;

7 cooling the molten substrate material; and

8 removing the formed device from the mold.

1 29. A method of manufacturing a therapeutic device for promoting the healing of a
2 wound in a mammal comprising the steps of:

3 providing a permeable substrate; and

4 forming a plurality of depressions into a surface of the permeable substrate.

1 30. The method of claim 29 wherein the step of forming the plurality of depressions
2 comprises heat stamping.

1 31. The method of claim 29 wherein the step of forming the plurality of depressions
2 comprises vacuum forming.

1 32. The method of claim 29 wherein the step of forming the plurality of depressions
2 comprises embossing.

1 33. The method of claim 29 wherein the step of forming the plurality of depressions
2 comprises cutting.

1 34. The method of claim 29 wherein the step of forming the plurality of depressions
2 comprises delivering convective heat across at least one surface of the structure at
3 approximately the melting temperature of the structure material.

1 35. A method of treating a wound comprising the steps of:

2 providing a permeable structure comprising a plurality of fibers and having i) a
3 plurality of wound surface contact elements disposed between end portions of the
4 structure, and ii) a plurality of voids defined by the contact elements; and

5 applying the permeable structure to at least one surface of the wound.

1 36. The method of claim 35 further comprising the steps of:

2 applying an adhesive film to at least a portion of the permeable structure
3 opposite the contact elements; and

- 14 -

4 detachably maintaining the permeable structure in intimate contact with the
5 surface of the wound using an adhesive film.

1 37. The method of claim 35 further comprising the step of detachably maintaining
2 the permeable structure in intimate contact with the surface of the wound using a
3 bandage wrap.

1 38. The method of claim 35 further comprising the step of detachably maintaining
2 the permeable structure in intimate contact with the surface of the wound using
3 suction.

1 39. The method of claim 35 further comprising the step of detachably maintaining
2 the permeable structure in intimate contact with the surface of the wound using an
3 wound packing.

1 40. The method of claim 35 further comprising the step of detachably maintaining
2 the permeable structure in intimate contact with the surface of the wound using an
3 inflatable bladder.

1 41. A method of treating a wound comprising the steps of:

2 providing a first permeable structure comprising:

3 i) a plurality of wound surface contact elements disposed between end
4 portions of the structure, and

5 ii) a plurality of voids defined by the contact elements;

6 applying the first permeable structure to the wound, at least a portion of the
7 contact elements engaging a portion of a surface of the wound;

8 removing the first permeable structure from the wound after a predetermined
9 time period along with at least a portion of necrotic tissue coupled to various ones of
10 the contact elements;

11 providing a second permeable structure comprising a medicinal agent based on
12 a condition of the wound; and

13 removing the second permeable structure from the wound after a second
14 predetermined time period.

1 42. The method according to claim 41, further comprising the steps of:

2 applying a third permeable structure to the wound, said third structure having a
3 plurality of depressions formed in a surface thereof.

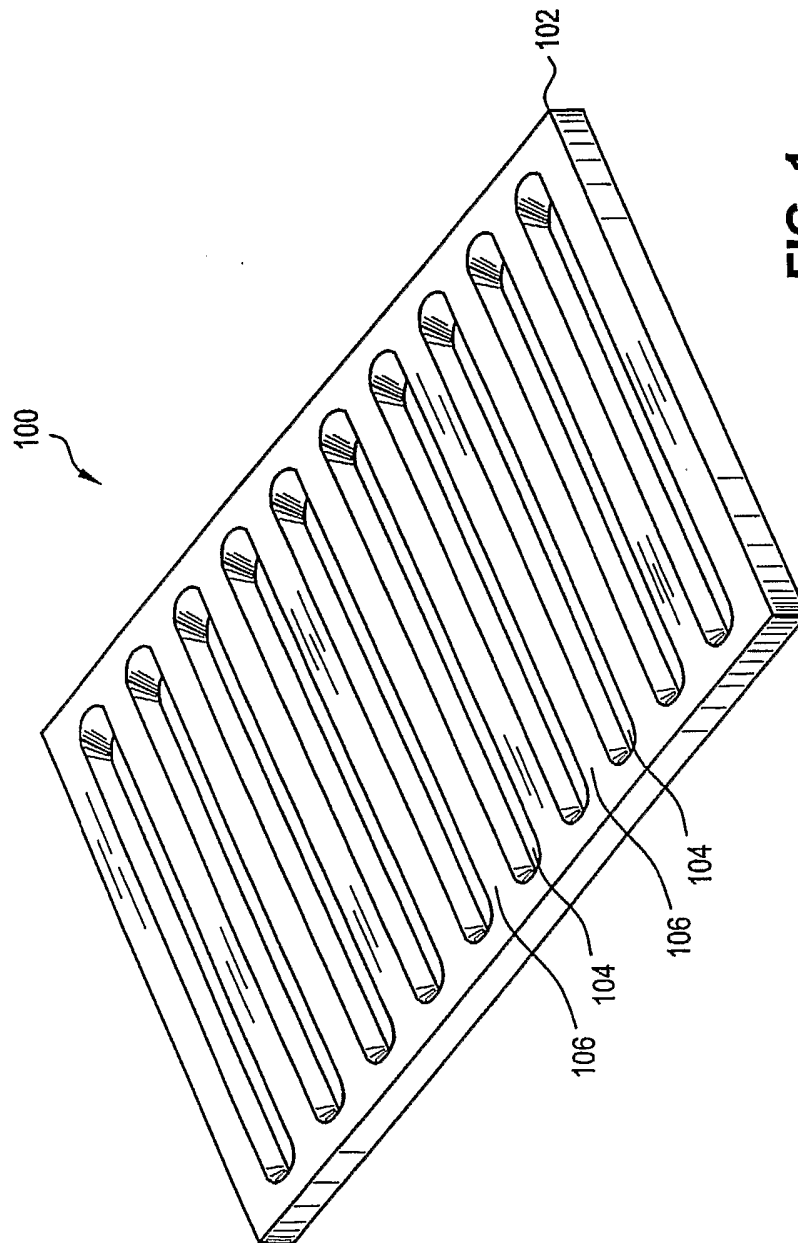

FIG. 1

2/6

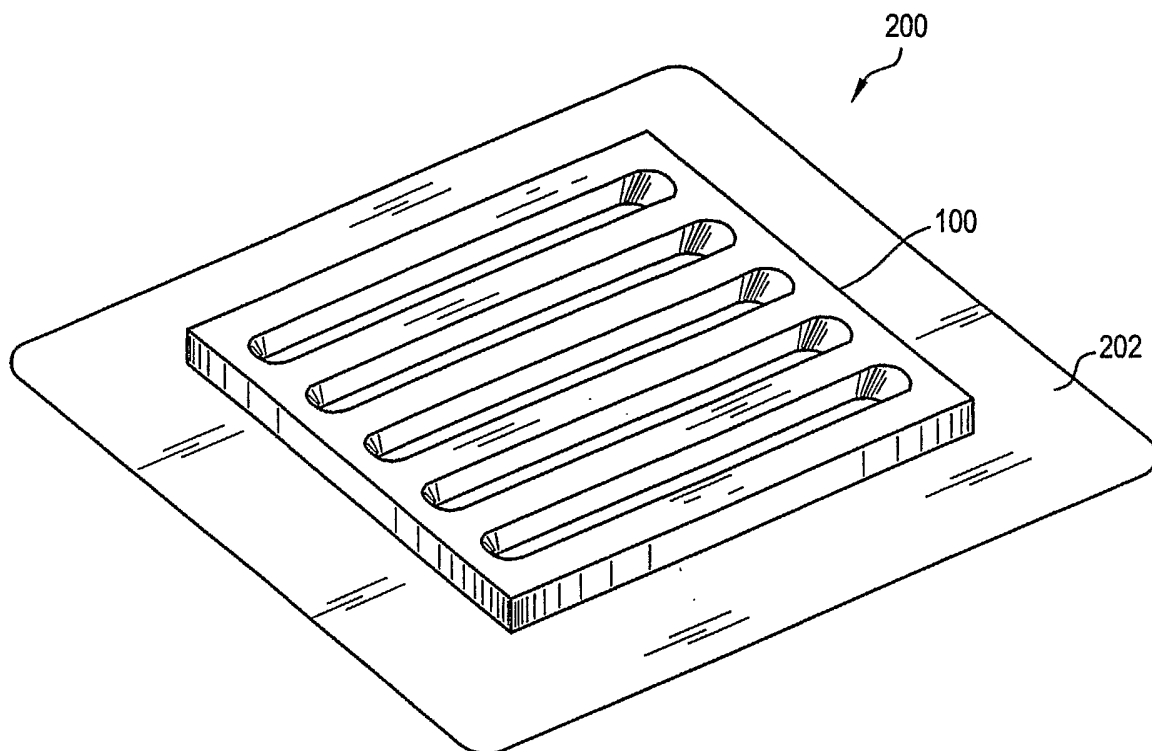

FIG. 2A

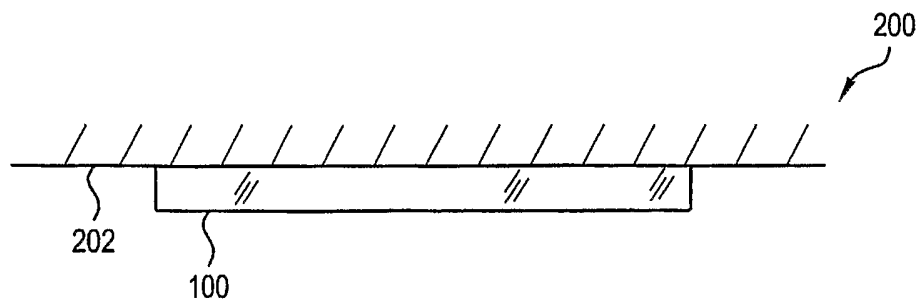

FIG. 2B

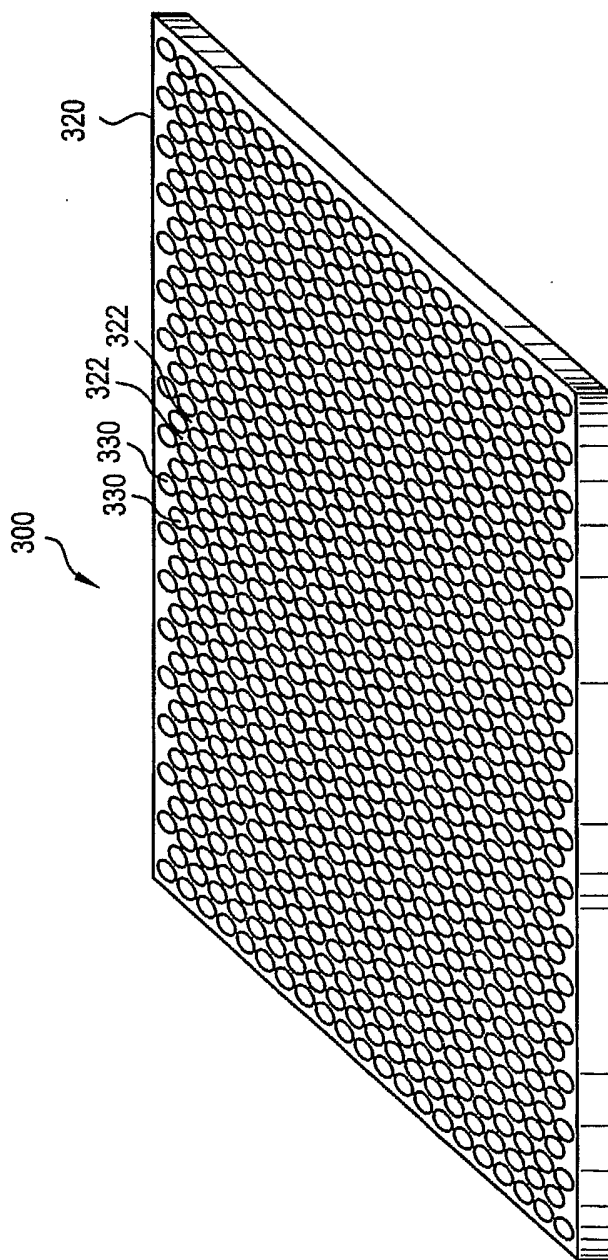

FIG. 3A

4/6

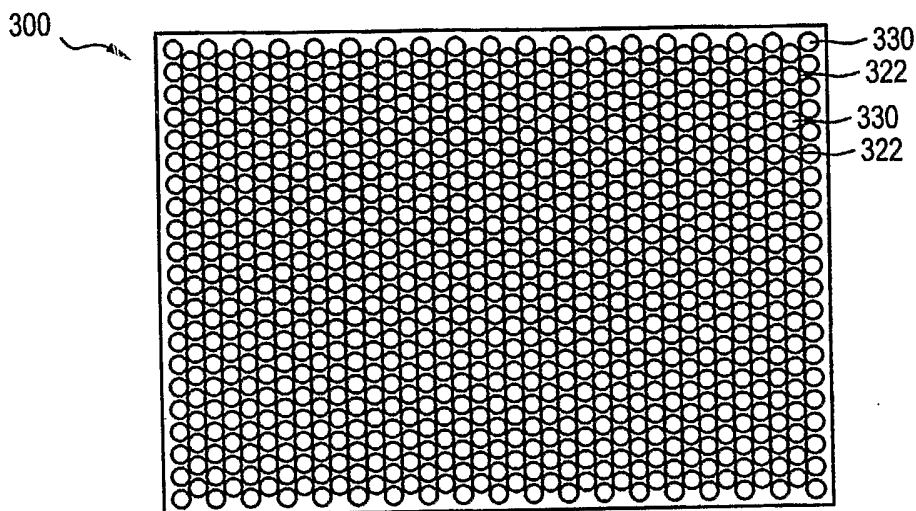

FIG. 3B

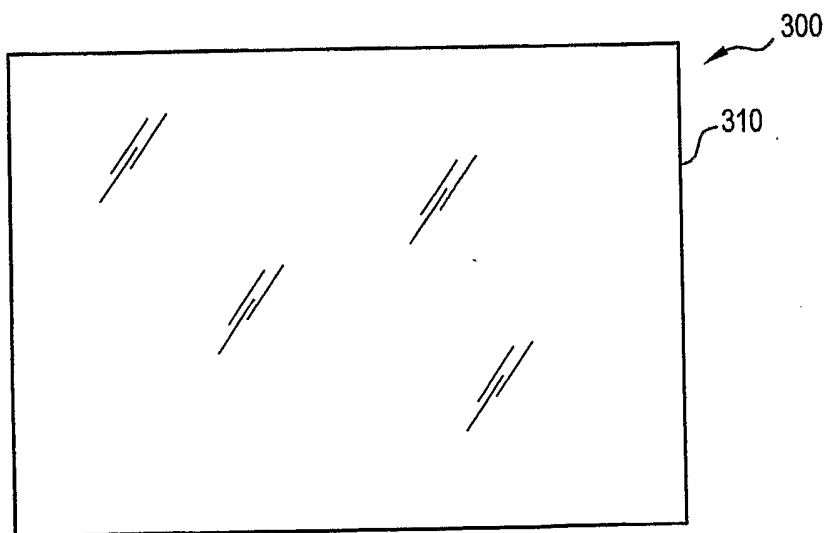

FIG. 3C

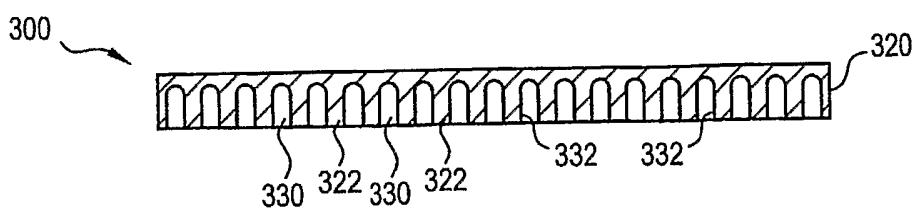

FIG. 3D

5/6

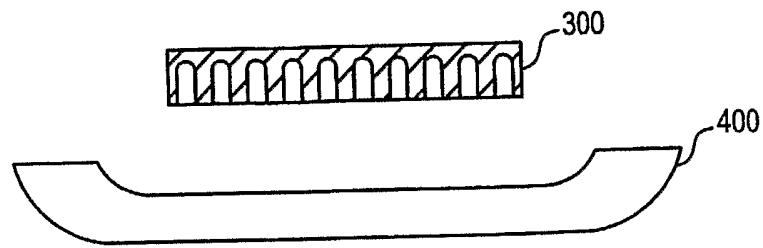

FIG. 4A

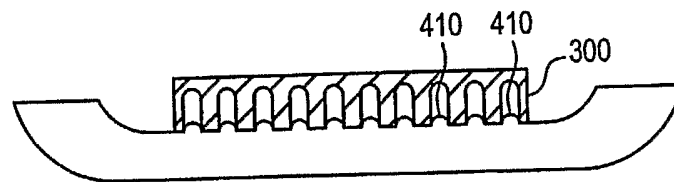

FIG. 4B

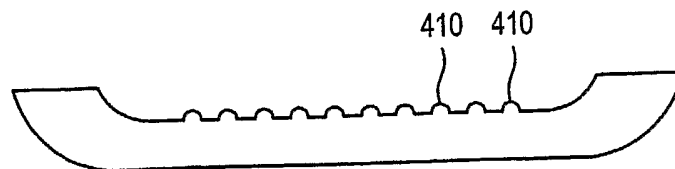

FIG. 4C

6/6

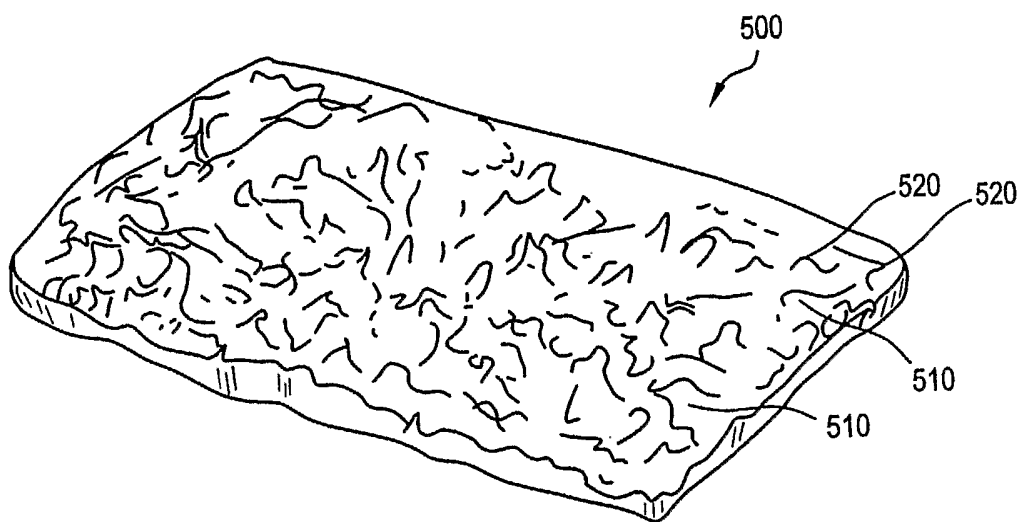

FIG. 5A



FIG. 5B