

Aug. 2, 1938.

H. LATHROP

2,125,294

FOLDABLE CLOCK DEVICE

Filed June 19, 1937

Fig. 1.

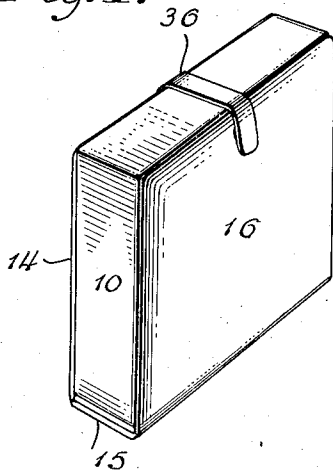

Fig. 2.

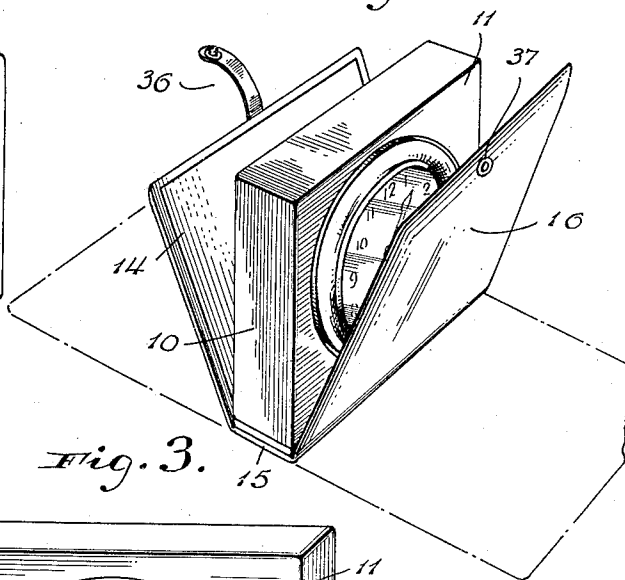

Fig. 3.

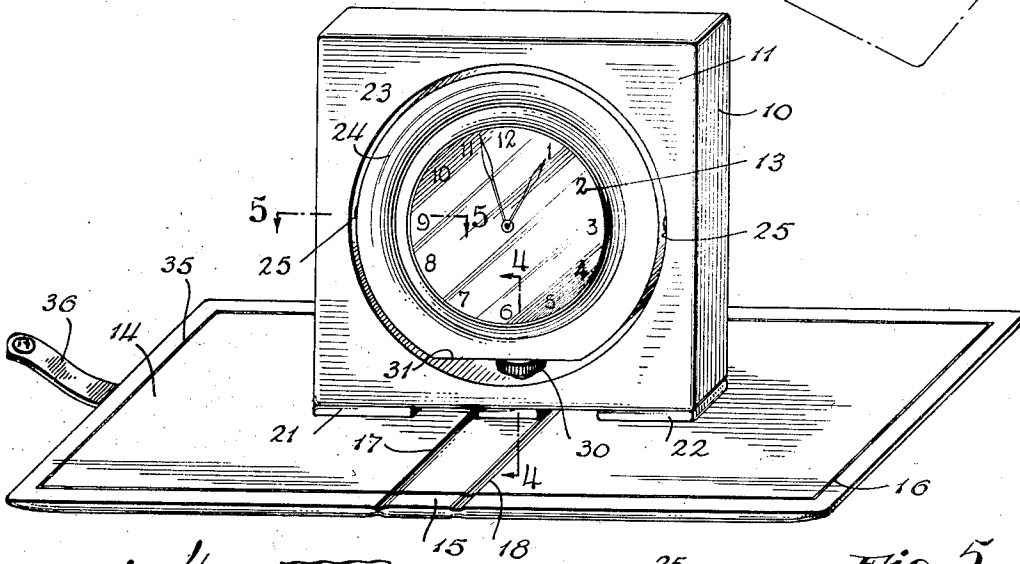

Fig. 4.

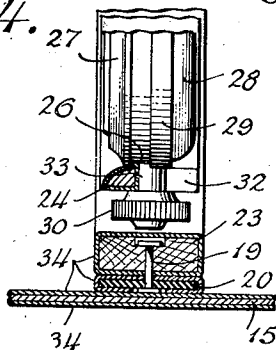
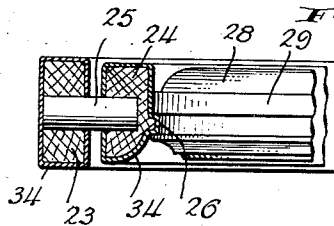

Fig. 5.



INVENTOR
HARVEY LATHROP
BY
Oderich G. Grentenfeldt
ATTORNEY

UNITED STATES PATENT OFFICE

2,125,294

FOLDABLE CLOCK DEVICE

Harvey Lathrop, Forest Hills, Long Island, N. Y.

Application June 19, 1937, Serial No. 149,052

2 Claims. (Cl. 206—44)

My present invention relates generally to the type of article known generally as "a traveler's clock", and has particular reference to a new and improved foldable clock device.

5 It is a primary object of my invention to provide an ornamental unit which includes a frame for a clock or the like, and associated parts which permit the unit to be folded into a compact form when it is to be packed in a suitcase or the like or transported from place to place.

10 A further object of the invention lies in providing a device which is so constructed that it may be opened to support and display the clock in upright position, the device thereupon presenting an unusually attractive and ornamental appearance.

15 It is a more particular object of the invention to provide a unit which, when opened up and in use, presents the appearance of a clock standing upright upon an ornamental flat base, the foldable nature of the unit being unapparent.

20 The present construction is characterized by the association with a frame for the clock of a base comprising three hinged panels, the medial panel being relatively narrow and being in pivotal association with the clock frame. When the device is to be folded up, the frame is swung into alignment with the medial panel, and the outer panels may thereupon be swung upwardly to sandwich the clock frame between them. When the device is to be opened, the three base panels are arranged in a horizontal plane, and the clock frame is swung crosswise with respect to the medial panel.

25 I achieve the foregoing objects, and such other objects as may hereinafter appear or be pointed out, in the manner illustratively exemplified in the accompanying drawing, wherein—

30 Figure 1 is a perspective view of a device constructed in accordance with the present invention, shown in folded condition;

Figure 2 is a view similar to Figure 1, showing the device in partially opened condition;

35 Figure 3 is a perspective view showing the device in fully opened and set-up condition;

Figure 4 is a fragmentary cross-sectional view taken substantially along the line 4—4 of Figure 3; and

40 Figure 5 is a fragmentary cross-sectional view taken substantially along the line 5—5 of Figure 3.

45 In the illustrated embodiment, I have shown a clock frame 10 of substantially square configuration, i. e., both the front face 11 and the rear face of the frame being arranged parallel to each other and having the same size and shape.

50 The frame 10 is provided with means for accommodating a clock 13, the clock lying in its entirety within the confines of the frame 10 and

presenting its face to view at approximately the midportion of the front face 11.

5 While I have referred to the timepiece as being a "clock", and shall use this term hereinafter and in the appended claims, it will be understood that the timepiece is preferably of the nature of an enlarged watch; and the term "clock" is, therefore, intended to signify any timepiece that may be suitable for the present type of device.

10 The base of the present device comprises the three flat panels 14, 15, and 16, hinged to each other along the hinge lines 17 and 18. The outer panels 14 and 16 preferably conform in size and shape to the front and rear faces of the frame 10. In the illustrated embodiment, the panel 14 has a substantially square configuration conforming to the size and conformation of the front face 11 of the frame 10; the other outer panel 16 corresponds in a similar manner to the rear face of the frame 10.

15 The medial panel 15 is relatively narrow and has a width substantially equal to the width of the frame bottom, i. e., the distance between the hinge lines 17 and 18 is substantially equal to the distance between the front and rear faces of the frame 10 at the bottom edge of the latter.

20 In accordance with my invention, the frame 10 is mounted upon the medial panel 15 for swinging movement of the frame around a vertical axis. This pivotal mounting may be accomplished in the manner illustrated most clearly in Figure 4, in which I have shown a vertical pivot pin 19 extending upwardly into the frame 10 and extending downwardly through a foot 20 which is adhesively or otherwise secured to the panel 15.

25 The object of this pivotal mounting is to permit the frame 10 to be swung between the position shown in Figures 2 and 3. In Figure 2, the frame is in substantial alignment with the medial panel 15, thereby permitting the outer panels 14 and 16 to be swung upwardly and downwardly relative to the frame 10. In Figure 3, the frame 10 has been swung across the hinge lines 17 and 18.

30 Preferably, the frame 10 carries the feet 21 and 22, having the same thickness as the foot 20, these feet bearing against the upper surfaces of the panels 14 and 16 when the frame is in the position of Figure 3. This serves to help in maintaining the panels 14 and 16 in flat horizontal relationship.

35 Preferably, but not necessarily, the frame 10 is composed of two parts, as illustrated most clearly in Figure 5, these parts consisting of an outer frame element 23 defining a medial aperture, and an inner frame element 24 mounted in the aperture for pivotal movement with respect to the frame element 23 along a horizontal axis. I have illustratively shown horizontal pivot pins 25 extending between the frame elements 23 and 24, 60

these pivot pins being in alignment and permitting the inner frame element 24 to be swung around a horizontal axis with respect to the outer frame element 23. This permits the inner frame element 24 to be adjusted at slight oblique inclinations to suit the convenience of the user of the device.

Also for illustrative purposes, I have shown the clock 13 in the form of an element which is removably secured to the inner frame element 24. My invention preferably provides for such removable association of the clock or watch with the frame 10.

In the form shown, the clock is substantially circular, as is the inner frame element 24; and the latter is provided with an inner rib 26 defining front and rear shoulders. The front cover 27 of the clock is removable with respect to the body 28 of the clock; and the latter is provided with a rib 29 which is adapted to bear against the rear shoulder defined by the rib 26. Similarly, the front cover 27 is adapted to bear against the front shoulder of the rib 26. Accordingly, the clock may be removably applied to the frame 10 by unscrewing or removing the front cover 27, and thereupon withdrawing the body 28 rearwardly.

In the illustrated clock, I have also shown a stem wind knob 30; and to make this knob accessible, the inner frame element 24 is flattened at the bottom, as shown at 31, leaving a recess within which the knob 30 is disposed. To permit the insertion and removal of the clock, the inner frame element 24 is also provided with a slot 32 to accommodate the stem 33 of the winding mechanism.

The details of the watch construction, and its manner of removable accommodation within the clock frame, do not form any part of the salient features of the present invention; and the details herein illustrated and hereinbefore described, so far as the clock construction and mounting are concerned, are offered merely for illustrative purposes.

Essentially, the novelty and advantages of the present construction lie in the ability to fold it up into the compact attractive unit shown in Figure 1, and to open it up into the pleasing relationship of parts shown in Figure 3.

While the several elements of the construction may be composed of any desired material, and may be constructed and assembled in any suitable or convenient manner, it is contemplated that the panels 14, 15, and 16 will be composed of flat cardboard or similar sheet material, completely covered over by leather or equivalent ornamental material. The frame 10, including both the outer and inner frame elements 23 and 24, are preferably made of wood; and this wood may also be covered over by ornamental leather or the like. By way of illustration, I have shown layers of leather designated by the reference numerals 34 in Figures 4 and 5, but it will be understood that any ornamental covering material may be used; or a covering material might be completely omitted, if desired.

It is also preferable to ornament the inner surfaces of the panels 14, 15, and 16, as indicated by the ornamental border 35 shown most clearly in Figure 3. This ornamentation is continuous across the hinge lines 17 and 18, so that when

the device is set up in opened condition the upper exposed surface of the base is provided with a continuous ornamentation which makes the base appear as though it were a single unit.

When the device is used, an unusually attractive clock-and-base device is presented to view. Where the frame is composed of the inner and outer elements 23 and 24, the clock may be conveniently tilted in an attractive manner. When the clock is to be wound or set, access is easily had to the knob 30 for this purpose. In the case of a clock having a winding and setting mechanism at the back, access for winding and setting purposes is even easier.

When it is desired to fold the device, for purposes of packing it in a suitcase or the like, it is merely necessary to swing the frame from the position of Figure 3 to the position of Figure 2, whereupon the outer panels 14 and 16 may be swung upwardly to sandwich the frame between them. The device may then be conveniently maintained in closed position by a strap 36 or its equivalent, preferably carried by one of the panels 14 and 16, adapted to extend across the frame 10, as shown in Figure 1, and having at its end one element of two cooperable snap fasteners or the like, the other fastening element being indicated at 37 in Figure 2. If desired, the strap 36 may be so mounted in association with the panel 14 that when the device is set up, it may be adjusted beneath the panel 14 so as to be completely concealed from view.

It will be obvious that the shape of the clock frame need not necessarily be square or even rectangular; that the clock, itself, need not have a circular contour; and that it is not even essential that the frame 10 have a uniform width from top to bottom.

In general, it will be obvious that changes in the details, herein described and illustrated for the purpose of explaining the nature of my invention, may be made by those skilled in the art without departing from the spirit and scope of the invention as expressed in the appended claims. It is, therefore, intended that these details be interpreted as illustrative, and not in a limiting sense.

Having thus described my invention, and illustrated its use, what I claim as new and desire to secure by Letters Patent, is:

1. In a foldable clock device, a frame for the clock, a base comprising three hinged panels, the medial panel having a width substantially equal to the width of the frame bottom, and means pivotally securing the frame to said medial panel for swinging movement of the frame around a vertical axis, whereby the device may be held open by swinging the frame across the hinge lines of the base, and whereby the device may be folded up by swinging the frame into alignment with said medial panel and swinging the outer panels upwardly to sandwich the frame between them.

2. In a foldable clock device, the combination with the elements of claim 1 of feet elements carried by the frame and adapted to bear against said outer panels when the device is open, thereby helping to retain said panels in flat alignment with the medial panel.

HARVEY LATHROP. 76