



(22) Date de dépôt/Filing Date: 2012/05/29

(41) Mise à la disp. pub./Open to Public Insp.: 2013/02/09

(30) Priorité/Priority: 2011/08/09 (US13/206,170)

(51) Cl.Int./Int.Cl. *E21B 17/00* (2006.01)

(71) Demandeur/Applicant:
BISEL, NEAL O., US

(72) Inventeur/Inventor:
BISEL, NEAL O., US

(74) Agent: STIKEMAN ELLIOTT LLP

(54) Titre : TIGE POLIE POURVUE D'UNE SECTION DE VERROUILLAGE

(54) Title: POLISHED ROD WITH LATCHING SECTION

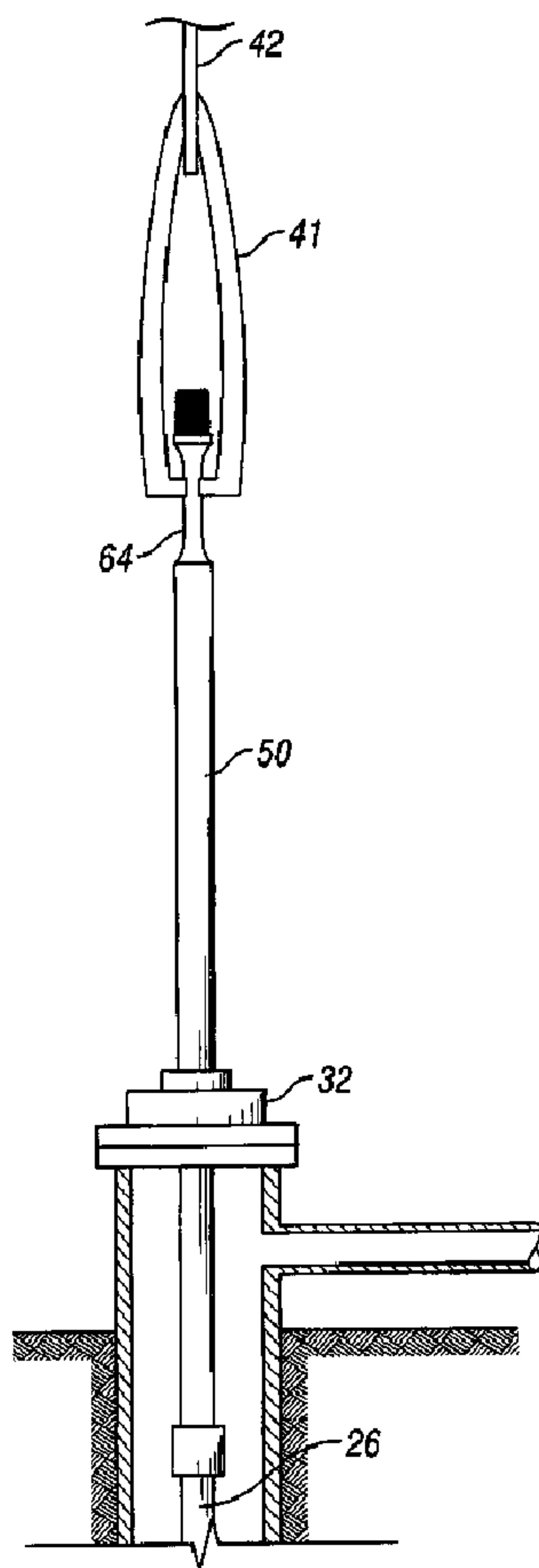

(57) Abrégé/Abstract:

A polished rod for supporting a sucker rod string comprising a one piece shank with an upper end and a lower end. A first connector is formed on the upper end of the shank and a second connector is formed on the lower end of the shank. The shank

(57) **Abrégé(suite)/Abstract(continued):**

has a sealing section extending from the lower end toward the upper end and the sealing section has a polished surface and a uniform cylindrical diameter substantially equal to the diameter of the upper end and the lower end of the shank. The shank further has a latching section formed between the sealing section and the upper end. The latching section of the shank has a diameter less than the diameter of the sealing section and the upper end.

ABSTRACT OF THE DISCLOSURE

A polished rod for supporting a sucker rod string comprising a one piece shank with an upper end and a lower end. A first connector is formed on the upper end of the shank and a second connector is formed on the lower end of the shank. The shank has a sealing section extending from the lower end toward the upper end and the sealing section has a polished surface and a uniform cylindrical diameter substantially equal to the diameter of the upper end and the lower end of the shank. The shank further has a latching section formed between the sealing section and the upper end. The latching section of the shank has a diameter less than the diameter of the sealing section and the upper end.

POLISHED ROD WITH LATCHING SECTION

BACKGROUND OF THE INVENTION

1. Field of the Invention

[0001] The inventive concepts disclosed herein generally relate to sucker rod strings for producing oil and gas, and more particularly, but not by way of limitation, to a polished rod having a latching section near the upper end of the polished rod with a reduced diameter on which a rod elevator can be attached .

2. Brief Description of Related Art

[0002] In the production of hydrocarbons from subsurface formations, it is common to use a sucker rod to lift fluids to the surface. Typical sucker rod pumps include a string of sucker rods extending from the earth's surface down to a downhole pump. A pump jack located on the surface is employed to reciprocate the sucker rod string and thus the downhole pump. The pump jack typically is a beam that pivots in a vertical plane and which is provided with a horse head at one end. The horse head supports a pair of bridle cables and a carrier bar.

[0003] A polished rod is suspended from the carrier bar and extended through a stuffing box. The lower end of the polished rod is attached to the upper end of the sucker rod string. The polished rod has a polished exterior surface to serve to form a seal with the stuffing box and thus force formation fluid that is lifted to the earth's surface to flow from production tubing to a collection conduit by which the produced fluid is conveyed to a tank battery, pipeline or other system whereby the produced fluid is collected.

[0004] The sucker rod string is formed of a series of individual sucker rods which are connected to one another in an end-to-end fashion so as to work together to lift the fluid from the ground. At times, the need arises to service the well or replace or maintenance the downhole pump. To do so requires the sucker rod string be removed from the well.

[0005] Removal of the sucker rod string starts with the removal of the polished rod. Because polished rods are manufactured with a smooth, polished shaft having a uniform diameter, a pony rod is typically attached to the upper end of the polished rod to provide a location at which an elevator can be attached. Pony rods are provided with a recessed section consisting of a smaller diameter than the diameter at its ends. This recessed section allows the rod elevator to be attached to the pony rod so that the rod string can be lifted from the well.

[0006] After the polished rod is lifted and detached from the sucker rod string, the remaining sucker rods in the rod string are removed without the assistance of a pony rod because the sucker rods have a latching area for the rod elevator. Thus, only the polished rod requires the use of the pony rod to facilitate its removal from the rod string.

[0007] While the use of pony rods has long been accepted in the petroleum industry, many inefficiencies are encountered in the use of pony rods. For example, because polished rods are manufactured in a variety of sizes, those servicing wells must maintain an inventory of a variety of sizes of pony rods, thereby increasing costs. More critical, however, is the fact that the steps required to install a pony rod on a polished rod places services personnel in

precarious positions above the well and thus exposes the service personnel to severe injury.

[0008] Therefore, a need exists for an improved polished rod that includes an integral latching section near an upper end to provide a latching area. It is to such an improved polished rod that the inventive concepts disclosed herein are directed.

BRIEF DESCRIPTION OF THE DRAWINGS

[0009] FIG. 1 is an elevation view of a prior art pumping unit.

[0010] FIG. 2 is an elevation view of the prior art pumping unit of FIG. 1 illustrating a pony rod attached to a polished rod.

[0011] FIG. 3 is an elevation view of the prior art polished rod.

[0012] FIG. 4 is an elevation view of a polished rod constructed in accordance with the inventive concepts disclosed herein.

[0013] FIG. 5 is an elevation view of polished rod of FIG. 4 shown suspended from a rod elevator.

DETAILED DESCRIPTION OF EXEMPLARY EMBODIMENTS

[0014] Before explaining at least one embodiment of the presently disclosed and claimed inventive concepts in detail, it is to be understood that the presently disclosed and claimed inventive concepts are not limited in their application to the details of construction, experiments, exemplary data, and/or the arrangement of the components set forth in the following description or illustrated in the drawings. The presently disclosed and claimed inventive concepts are capable of other embodiments or of being practiced or carried out in various

ways. Also, it is to be understood that the phraseology and terminology employed herein is for purpose of description and should not be regarded as limiting.

[0015] Referring now to the drawings, and in particular FIG. 1, one version of a conventional beam pumping unit 10 is illustrated. The pumping unit 10 includes a pump jack 12 that drives a downhole reciprocating pump (not shown) located in a wellbore 14. The pump jack 12 has a walking beam 16 with a horse head 18 located at one end. Activation of a primary mover 20 causes the horse head 18 to deliver a reciprocal pumping stroke to the downhole pump. A carrier bar 22 is suspended from bridle cables 24a and 24b which roll tangentially over the horse head 18 as it reciprocates. A string of sucker rods 26 is suspended from the carrier bar 22, and the sucker rod string 26 extends down production tubing 28 to drive the pump.

[0016] A polished rod 30 is connected to the top of the sucker rod string 26. The polished rod 30 extends through a stuffing box 32 and through the carrier bar 22. A rod clamp 34 is secured to the polished rod 30 above the carrier bar 22 to support the sucker rod string 26 while the weight is carried by the bridle cables 24a and 24b and the carrier bar 22.

[0017] Referring now to FIG. 2, one version of a prior art pony rod 36 is shown connected to the upper end of the polished rod 30 with a coupler 38. The pony rod 36 includes a recessed section 40. A rod elevator 41 which is supported by a rod hook 42 is shown latched to pony rod 36 at the recessed

section 40 of the pony rod 36. The rod hook 42 is connected to an external hoist (not shown).

[0018] The prior art polished rod 30 is best shown in FIG. 3 as including shank 43 with a threaded upper pin connector 44, and a threaded lower pin connector 46. The shank 43 has a uniform diameter and a polished surface 48 which travels slidably through the stuffing box 32 (FIG. 1) such that a hydraulic seal is maintained.

[0019] As discussed above, removal of the sucker rod string 26 from the well bore 14 entails disconnecting the carrier bar 22 and the rod clamp 34 from the polished rod 30 and attaching the pony rod 36 to the upper end of the polished rod 30 to allow the rod elevator 42 to be latched to the sucker rod string 26 and the external hoist (not shown) to be used to lift the sucker rod string 26 from the wellbore 14 so that the polished rod 30 may be disconnected from the remainder of the sucker rod string 26. As will be appreciated, the process of attaching a typical pony rod to sucker rod string prior to removal of the sucker rod string from a wellbore is cumbersome and inefficient. In addition, because the upper end of the polished rod often extends a considerable height above the stuffing box, personnel are exposed to hazardous conditions during the process of installing a pony rod.

[0020] Referring now to FIG. 4, one embodiment of a polished rod 50 constructed in accordance with the inventive concepts disclosed herein is illustrated. The polished rod 50 includes a unitary or one piece shank 52 having an upper end 54 and a lower end 56. The shank 52 may be formed of a variety of

materials, such as steel and steel alloy. The upper end 54 and the lower end 56 each have a diameter. A first connector 58 is formed on the upper end 54 of the shank 52, and a second connector 60 is formed on the lower end 56 of the shank 42. In one embodiment, the first and second connectors 58 and 60 may be in the form of threaded rod pin connectors. However, it should be appreciated that the connectors may be in a variety of forms.

[0021] The shank 52 further includes at least one sealing section 62 and a latching section 64. The sealing section 62 extends from the lower end 56 of the shank 62 towards the upper end 54 of the shank 52, and the latching section 64 is formed between the sealing section 62 and the upper end 54 of the shank 52. It will be appreciated, however, that the shank 52 may be formed to include a latching section on both the lower end 56 and the upper end 54.

[0022] The sealing section 62 is configured to travel slidably through the stuffing box such that a hydraulic seal is maintained. To this end, the sealing section 62 has a polished surface 66 and a uniform diameter which is substantially equal to the diameter of the upper end 54 and the lower end 56 of the shaft 52. In one embodiment, the polished surface 66 has a surface finish in a range of about 8 $\mu\text{in.}$ to about 32 $\mu\text{in.}$ However, it will be appreciated that a variety of surface finishes may be utilized. In addition, it will be appreciated that the length and diameter of the sealing section 62 may be varied, but typically the length will be in a range of eight feet to forty feet. Finally, it will be appreciated by those of ordinary skill in the art that a polished rod liner (not shown) may be

secured about the sealing section 62 whereby the polished rod liner forms the hydraulic seal with the stuffing box.

[0023] The latching section 64 of the shank 52 is characterized as having a diameter less than the diameter of the sealing section 62 and the upper end 54 so as to define a recessed area on the polished rod 50 on which a rod elevator may latch. In one embodiment, the length of the latching section 64 is less than the length of the sealing section 62, and the latching section 62 has a generally cylindrical cross-section to permit latching of a rod elevator to the latching section 62.

[0024] In use, the polished rod 50 is connected to the upper end of the sucker rod string 26 in a manner similar to that described above in relation to the polished rod 30. The polished rod 50 extends through the stuffing box 32 and through the carrier bar 22. The rod clamp 34 is secured to a selected location on the sealing section 62 of the shank 52 above the carrier bar 22 to support the sucker rod string 26 while the weight is carried by the bridle cables 24a and 24b and the carrier bar 22.

[0025] With reference to FIG. 5, removal of the sucker rod string 26 simply requires disconnecting the carrier bar 22 and the rod clamp 34 from the polished rod 30 and attaching the rod elevator 41, which is connected to the rod hook 42 and the external hoist (not shown), to the latching section 64 of the shank 52. Due to the presence of the polished rod 50, the rod elevator 41 attaches directly to the polished rod 50 rather than to a pony rod that must first be installed. Thus, employment of the polished rod 50 eliminates the need to insert the pony rod 26

into the sucker rod string before the polished rod 50 and the sucker rod string 26 are lifted from the wellbore 12.

[0026] From the above description, it is clear that the present inventive concept is well adapted to carry out the objects and to attain the advantages mentioned herein as well as those inherent in the invention. While exemplary embodiments of the invention have been described for purposes of this disclosure, it will be understood that numerous changes may be made which will readily suggest themselves to those skilled in the art and which are accomplished within the spirit of the inventive concept disclosed and claimed herein.

What is claimed is:

1. A polished rod for supporting a sucker rod string, comprising:
a one piece shank having an upper end and a lower end, the upper end and lower end each having a diameter;
a first connector formed on the upper end of the shank; and
a second connector formed on the lower end of the shank,
wherein the shank has a sealing section extending from the lower end toward the upper end, the sealing section having a polished surface and a uniform cylindrical diameter substantially equal to the diameter of the upper end and the lower end of the shank,
wherein the shank has a latching section formed between the sealing section and the upper end, the latching section of the shank having a diameter less than the diameter of the sealing section and the upper end.
2. The polished rod of claim 1 wherein the length of the latching section is less than the length of the sealing section.
3. The polished rod of claim 1 wherein the latching section has a cylindrical cross-section.
4. The polished rod of claim 1 wherein the polished surface has a surface finish in a range of about 8 μ in. to about 32 μ in.

5. A polished rod for supporting a sucker rod string, comprising:
a one piece shank having an upper end and a lower end, the upper end and lower end each having a diameter;
a first threaded rod pin formed on the upper end of the shank; and
a second threaded rod pin formed on the lower end of the shank,
wherein the shank has a sealing section extending from the lower end toward the upper end, the sealing section having a polished surface and a uniform cylindrical diameter substantially equal to the diameter of the upper end and the lower end of the shank,
wherein the shank has a latching section formed between the sealing section and the upper end, the latching section of the shank having a diameter less than the diameter of the sealing section and the upper end.
6. The polished rod of claim 5 wherein the length of the latching section is less than the length of the sealing section.
7. The polished rod of claim 5 wherein the latching section has a cylindrical cross-section.
8. The polished rod of claim 5 wherein the polished surface has a surface finish in a range of about 8 $\mu\text{in.}$ to about 32 $\mu\text{in.}$

1/4

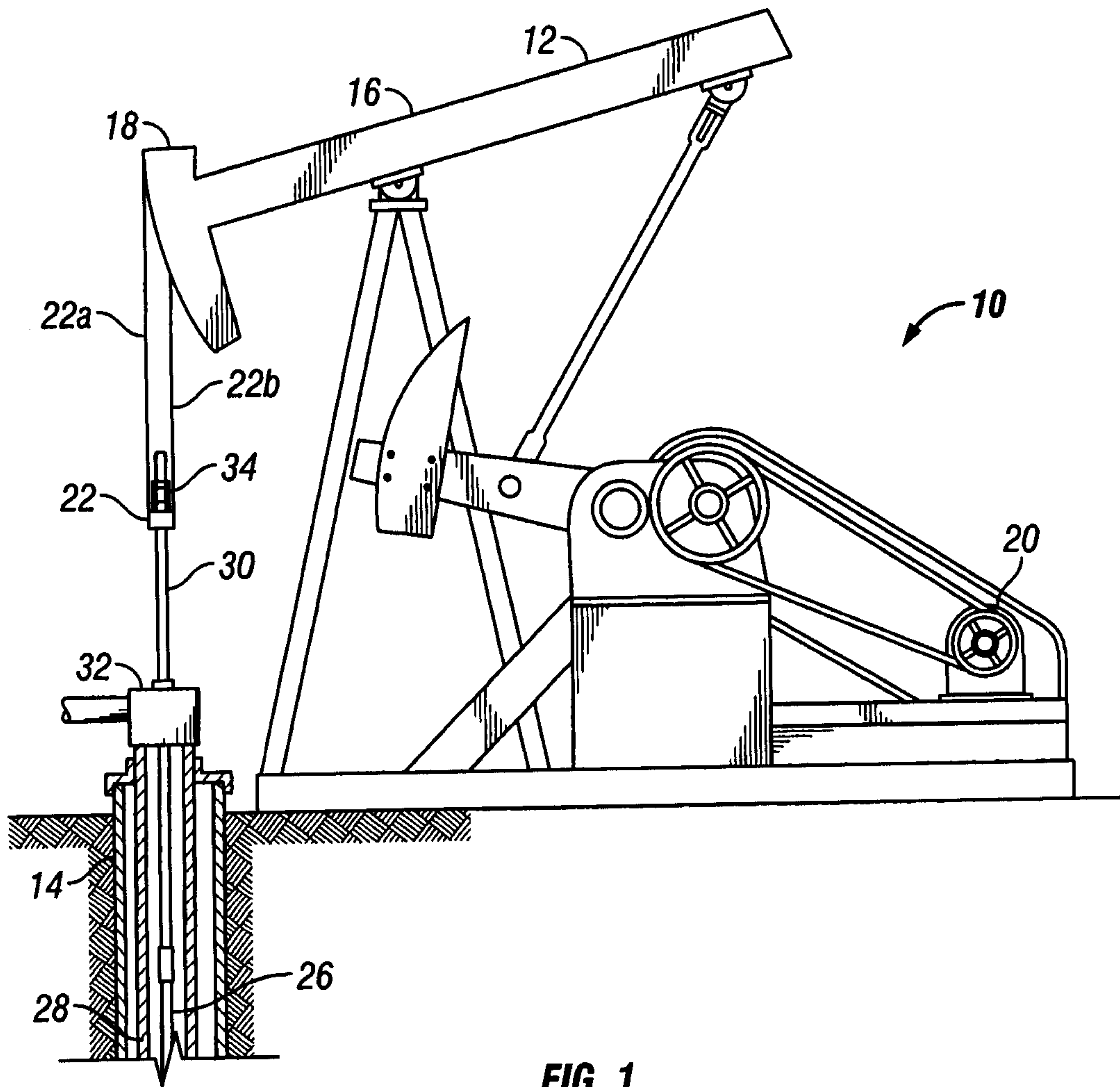

FIG. 1
(Prior Art)

2/4

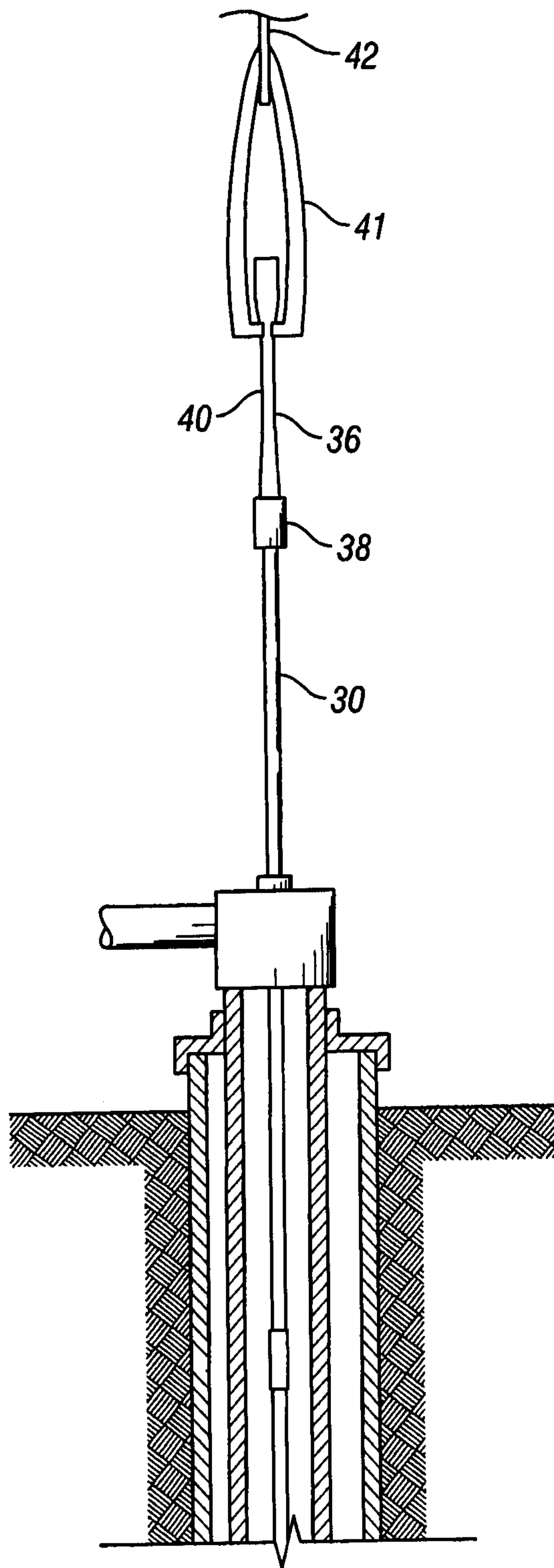

FIG. 2
(Prior Art)

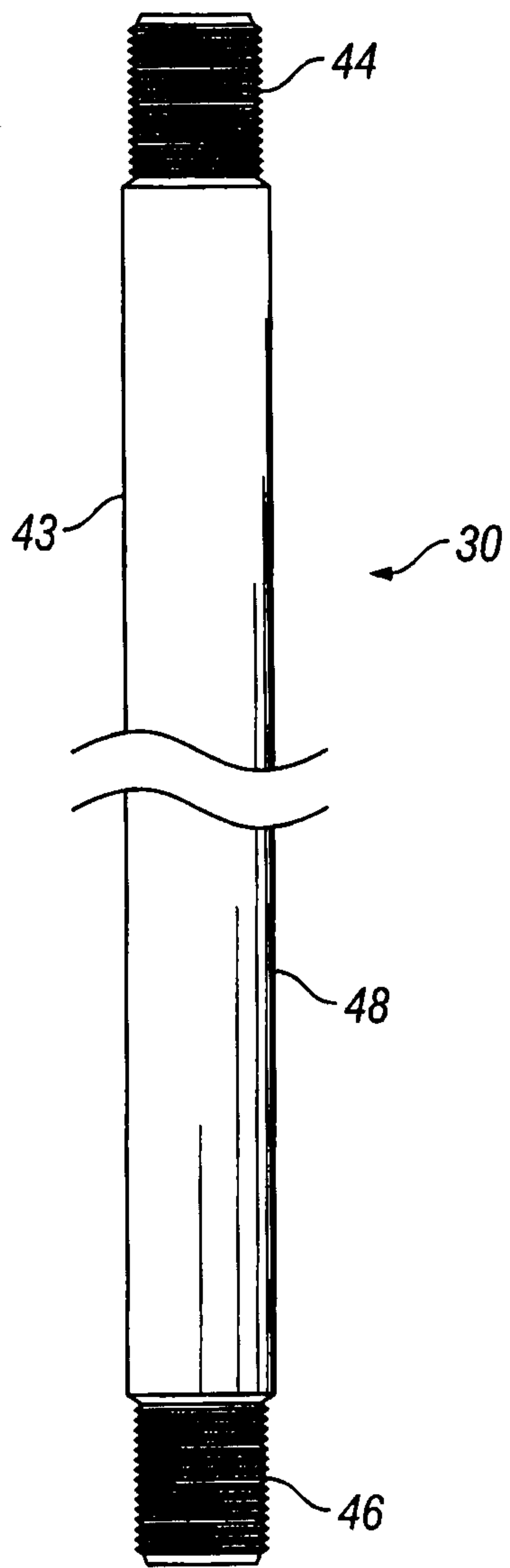

FIG. 3
(Prior Art)

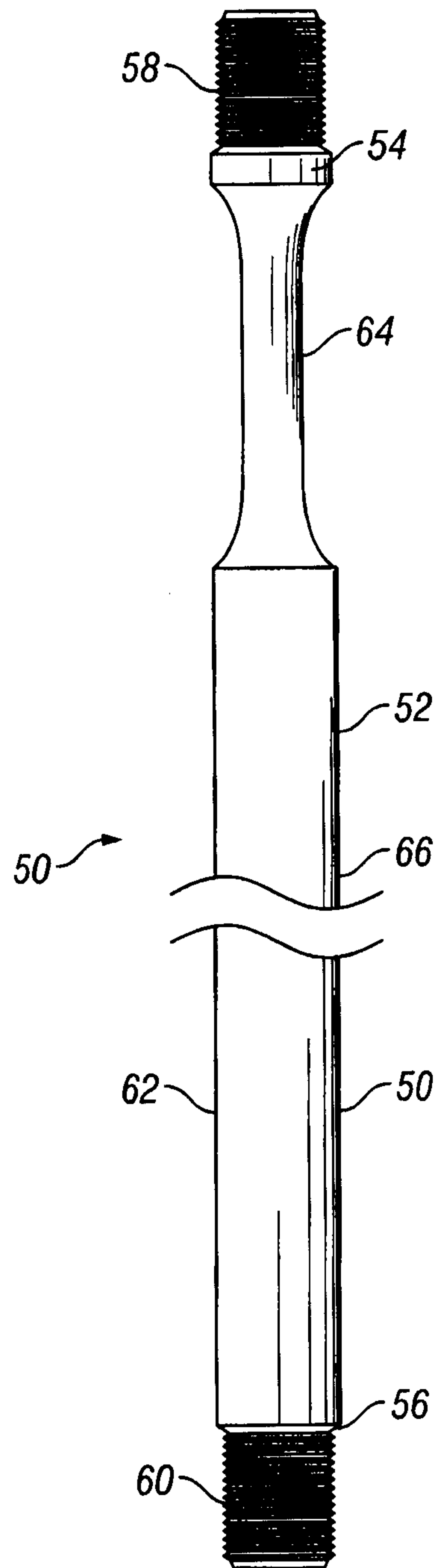

FIG. 4

4/4

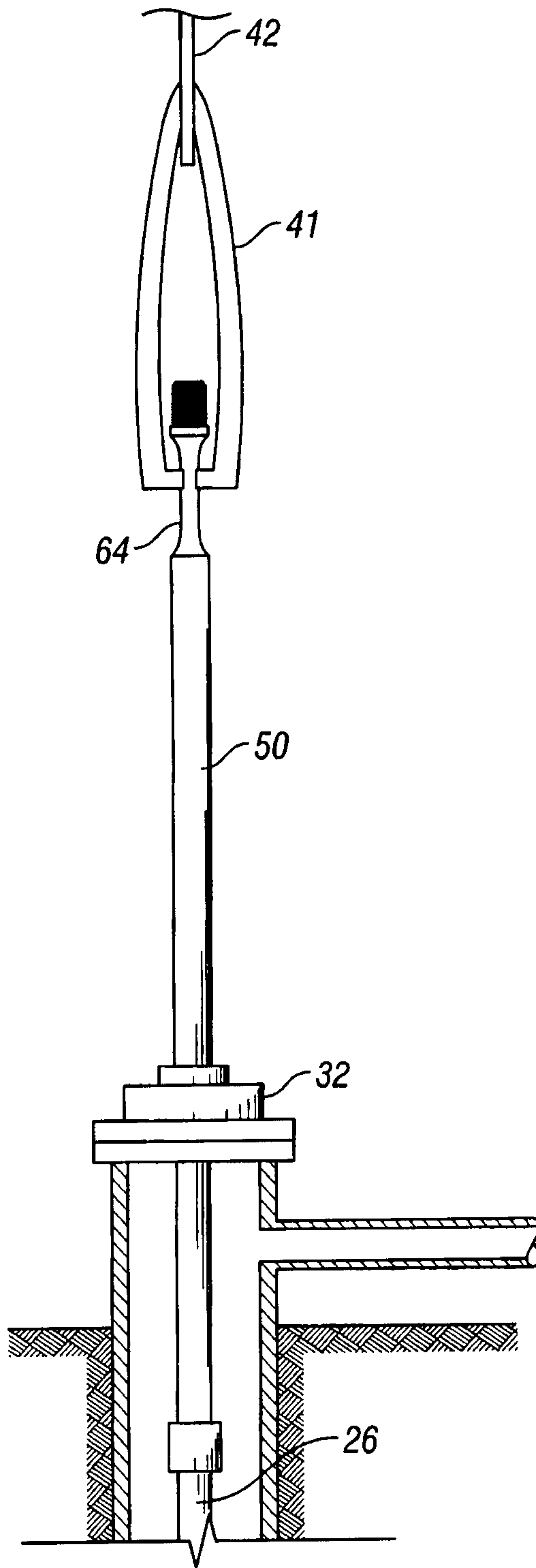

FIG. 5

