



INTERNATIONAL APPLICATION PUBLISHED UNDER THE PATENT COOPERATION TREATY (PCT)

<p>(51) International Patent Classification⁶ : C08J 9/00</p>	<p>A1</p>	<p>(11) International Publication Number: WO 00/17258 (43) International Publication Date: 30 March 2000 (30.03.00)</p>
<p>(21) International Application Number: PCT/US99/21423 (22) International Filing Date: 17 September 1999 (17.09.99) (30) Priority Data: 09/156,937 18 September 1998 (18.09.98) US (71) Applicant: CAPITOL SPECIALTY PLASTICS, INC. [US/US]; 151 Riverside Drive, Fultonville, NY 12072 (US). (72) Inventor: HEKAL, Ihab, M.; 121 Blackberry Drive, Stamford, CT 06903 (US). (74) Agent: SCHINDLER, Barry, J.; Dreier & Baritz, LLP, 499 Park Avenue, New York, NY 10022 (US).</p>		<p>(81) Designated States: AU, BR, CA, CN, JP, NO, NZ, European patent (AT, BE, CH, CY, DE, DK, ES, FI, FR, GB, GR, IE, IT, LU, MC, NL, PT, SE). Published <i>With international search report. Before the expiration of the time limit for amending the claims and to be republished in the event of the receipt of amendments.</i></p>

(54) Title: MONOLITHIC POLYMER COMPOSITION HAVING AN ABSORBING MATERIAL

(57) Abstract

The present invention includes processes and resulting structures for producing a modified polymer (25) having interconnecting channels (45). The interconnecting channels (45) act as controlled transmission passages through the polymer. A hydrophilic agent (35) is blended into the polymer so that it is distributed within the polymer. In one embodiment, an absorbing material (30) is blended into the polymer so that the absorbing material is distributed within the product. The product is solidified so that the hydrophilic agent

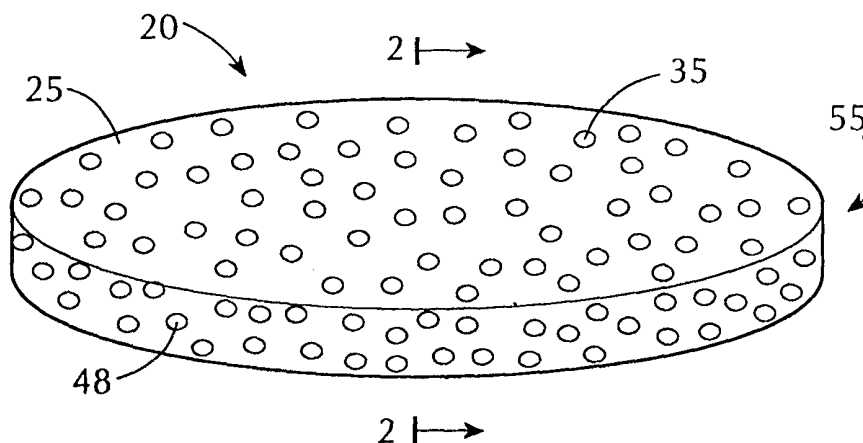

(35) forms passages (45) in the product through which a desired composition is communicable to the absorbing material (30) that is entrained within the product. The solidified product may be used to form a desired shaped article such as plug type inserts (55) and liners (70) for closed containers, or it may be formed into a film, sheet (75), bead, or pellet.

FOR THE PURPOSES OF INFORMATION ONLY

Codes used to identify States party to the PCT on the front pages of pamphlets publishing international applications under the PCT.

AL	Albania	ES	Spain	LS	Lesotho	SI	Slovenia
AM	Armenia	FI	Finland	LT	Lithuania	SK	Slovakia
AT	Austria	FR	France	LU	Luxembourg	SN	Senegal
AU	Australia	GA	Gabon	LV	Latvia	SZ	Swaziland
AZ	Azerbaijan	GB	United Kingdom	MC	Monaco	TD	Chad
BA	Bosnia and Herzegovina	GE	Georgia	MD	Republic of Moldova	TG	Togo
BB	Barbados	GH	Ghana	MG	Madagascar	TJ	Tajikistan
BE	Belgium	GN	Guinea	MK	The former Yugoslav Republic of Macedonia	TM	Turkmenistan
BF	Burkina Faso	GR	Greece	ML	Mali	TR	Turkey
BG	Bulgaria	HU	Hungary	MN	Mongolia	TT	Trinidad and Tobago
BJ	Benin	IE	Ireland	MR	Mauritania	UA	Ukraine
BR	Brazil	IL	Israel	MW	Malawi	UG	Uganda
BY	Belarus	IS	Iceland	MX	Mexico	US	United States of America
CA	Canada	IT	Italy	NE	Niger	UZ	Uzbekistan
CF	Central African Republic	JP	Japan	NL	Netherlands	VN	Viet Nam
CG	Congo	KE	Kenya	NO	Norway	YU	Yugoslavia
CH	Switzerland	KG	Kyrgyzstan	NZ	New Zealand	ZW	Zimbabwe
CI	Côte d'Ivoire	KP	Democratic People's Republic of Korea	PL	Poland		
CM	Cameroon	KR	Republic of Korea	PT	Portugal		
CN	China	KZ	Kazakstan	RO	Romania		
CU	Cuba	LC	Saint Lucia	RU	Russian Federation		
CZ	Czech Republic	LI	Liechtenstein	SD	Sudan		
DE	Germany	LK	Sri Lanka	SE	Sweden		
DK	Denmark	LR	Liberia	SG	Singapore		
EE	Estonia						

MONOLITHIC POLYMER COMPOSITION HAVING
AN ABSORBING MATERIAL

RELATED APPLICATION:

This application is a continuation-in-part of U.S. Serial 09/087,830, filed May 29, 1998, which in turn is a continuation-in-part of U.S. Serial 08/812,315, filed March 5, 1997, which in turn is a continuation-in-part of U.S., Serial No. 08/611,298, filed on March 5, 1996, which in turn is a continuation-in-part of U.S. Serial No. 08/424,996, filed April 1995.

FIELD OF THE INVENTION:

This invention generally relates to monolithic compositions comprising a water-insoluble polymer, a hydrophilic agent and an absorbing material. In one embodiment, the present invention relates to modified polymers blended with one or more absorbing materials to form an absorbing material entrained polymer. The invention further relates to an entrained polymer that includes means by which the absorbing material located within interior portions of the polymer structure are exposed to conditions that are exterior to the polymer body. In one embodiment, the entrained polymer of the present invention is useful in the manufacture of containers and packaging for items requiring controlled environments.

BACKGROUND OF THE INVENTION:

There are many items that are preferably stored, shipped and/or utilized in an environment that must be controlled and/or regulated. For example, in the moisture control area, containers and/or packages having the ability to absorb excess moisture trapped therein have been recognized as desirable. One application in which moisture absorbing containers are desired is for the shipment and storage of medications whose efficacy is compromised by moisture. The initial placement of medicines into a sealed moisture free container is usually controllable. Furthermore, the container for the medicine is selected so that it has a low permeability to moisture. Therefore, the medication will normally be protected from moisture until it reaches the end user. Once the medicine is received by the customer, however, the container must be repeatedly opened and closed to access the medication. Each time the container is opened and unsealed, moisture bearing air will most likely be introduced into the container and sealed therein upon closure. Unless this moisture is otherwise removed from the atmosphere or head space of the container, it may be detrimentally absorbed by the medication. For this reason, it is a well known practice to include a desiccating unit together with the medication in the container.

Other items, electronic components may require reduced moisture conditions for optimal performance. These components may be sealed in containers, but excess moisture that is initially trapped therein must be removed. Furthermore, the housings may not be completely moisture tight, and moisture may be allowed to seep into the container. This moisture must also be retained away from the working components. For these reasons, it is important to include a desiccating agent within the housing for absorbing and retaining excess moisture. Because of the delicacy of many of the components that are to be protected from the moisture, it is important that the desiccant used not be of a "dusting" nature that may contaminate and compromise the performance of the components. Therefore, it has been recognized as advantageous to expose a desiccating agent to the interior space of such containers, while at the same time shielding the working components from actual contact with the desiccating material, including desiccant dust that may be produced therefrom.

In other instances, moisture may be released from items that have been placed in containers or sealed in packaging wrap for shipping and/or storage. Prime examples of such items are food stuffs-that release moisture during shipping and storage. In the instance of containers that are sealed and substantially impermeable to moisture, the released moisture will remain within the container. If not removed, this released moisture may have ill effects on the very item that released the moisture. It has been found that a substantial amount of moisture is released from certain food products within the first forty-eight (48) hours after manufacture and packaging. This released moisture will remain until removed. If the moisture is not removed shortly after its release, it may cause the food to degrade into a condition that is not saleable. In these cases, desiccants may be included together with the contained items to continually absorb the released moisture until the product is unpacked. In this way, a relatively dry environment is maintained about the stored item.

SUMMARY OF THE INVENTION:

The present invention discloses both a structure and a method by which interconnecting channels are established throughout the composition. These interconnecting channels communicate the entrained absorbing material to the appropriate areas of the exterior of the composition in a manner that permits the desired property (e.g., gases and vapors) to migrate from outside the plastic structure to interior locations where the absorbing material is positioned. Furthermore, these interconnecting channels through which the desired property is permitted to

travel are occupied by hydrophilic agents (e.g., channeling agents) that control the transmission rate into the composition. The hydrophilic agents are used to act as bridges from the surface of the composition inwardly to the absorbing material positioned within the composition.

BRIEF DESCRIPTION OF DRAWINGS:

Figure 1 is a perspective view of a plug, insert, or tablet constructed from the composition of the present invention showing, in an exaggerated scale, the openings of the interconnecting channels at the exterior surface of the plug.

Figure 2 is an exaggerated, cross-sectional view of a solidified plug formed from a water-insoluble polymer having a hydrophilic agent and an absorbing material blended therewith.

Figure 3 is an exaggerated cross-sectional view of a portion of a container having the composition of the present invention formed into a plug insert located in the bottom of a container constructed from a polymer that acts as a transmission rate barrier.

Figure 4 is an exaggerated cross-sectional view of a portion of a container the composition of the present invention formed into a plug that has been comolded into the bottom of a container that is constructed from a polymer that acts as a transmission rate barrier.

Figure 5 is an exaggerated cross-sectional view of a portion of a container the composition of the present invention formed into a liner insert located within the interior of a container constructed from a polymer that acts as a transmission rate barrier.

Figure 6 is an exaggerated cross-sectional view of a portion of a container having the composition of the present invention formed into a liner that has been comolded at the interior of a container that is constructed from a polymer that acts as a transmission rate barrier.

Figure 7 is an exaggerated cross-sectional view of the composition of the present invention formed into a sheet located adjacent to a barrier sheet constructed from a polymer that acts as a transmission rate barrier.

Figure 8 is an exaggerated cross-sectional view the composition of the present invention formed into a sheet that has been comolded at an interior of a barrier sheet so that the products are integrally molded together and comprise one unified laminate.

Figure 9 is a graphical view of a swelling and weight loss analysis of three film samples: Film #2, Film #3 and Film #4.

Figure 10 is a graphical view of a DSC curve of a sample of 100% polyglycol.

Figure 11 is a graphical view of a DSC curve of a sample of Film #4.

Figure 12 is a graphical view of a DSC curve of a sample of Film #5.

Figure 13 is a graphical view of an DSC curve of a sample of Film #6.

Figure 14 is a graphical view of a DSC curve of a sample of Film #7.

Figure 15 is a graphical view of a DSC curve of a sample of Film #2 in a pre-incubation state.

Figure 16 is a graphical view of a DSC curve of a sample of Film #2 in a post-incubation state.

Figure 17 is a graphical view of a DSC curve of a sample of Film #3 in a pre-incubation state.

Figure 18 is a graphical view of a DSC curve of a sample of Film # 3 in a post-incubation state.

Figure 19a-c are scanning electron photomicrographs of a film sample of Film #4.

Figure 20a-c are scanning electron photomicrographs of a film sample of Film #5.

Figure 21a-c are scanning electron photomicrographs of a film sample of Film #6.

Figure 22a-d are scanning electron photomicrographs of a film sample of Film #3.

Figures 23a and 23b is a graphical view of showing the percent moisture gain per weight of molecular sieve at 10% Rh and 72°F and 20% RH and 72°F, respectively.

Among those benefits and improvements that have been disclosed, other objects and advantages of this invention will become apparent from the following description taken in conjunction with the accompanying drawings. The drawings constitute a part of this specification and include exemplary embodiments of the present invention and illustrate various objects and features thereof.

DETAILED DESCRIPTION OF THE INVENTION:

As required, detailed embodiments of the present invention are disclosed herein; however, it is to be understood that the disclosed embodiments are merely exemplary of the invention that may be embodied in various forms. The figures are not necessarily to scale, some features may be exaggerated to show details of particular components. Therefore, specific structural and functional details disclosed herein are not to be interpreted as limiting, but merely as a basis for

the claims and as a representative basis for teaching one skilled in the art to variously employ the present invention.

It has been discovered that certain compounds, which are referred to herein as hydrophilic agents (e.g., channeling agents), may be combined with a water-insoluble polymer that is used in the formation of shaped articles. In practice, in one embodiment water-insoluble polymer base into which the hydrophilic agent is blended includes, as examples, any polyethylene and polypropylene.

In one embodiment, an absorbing material and hydrophilic agent are added to the water-insoluble polymer when the polymer is in a molten state or before the polymer is in the molten state, so that the material and hydrophilic agent may be blended and thoroughly mixed throughout the polymer to insure that the blend is uniformly mixed before reaching the melt phase. For example, such a technique is useful when the absorbing material, hydrophilic agent and polymer are all powders.

In another embodiment, the hydrophilic agent and polymer are mixed prior to adding the absorbing material. The hydrophilic agent is added either before the polymer is in the molten state or after the polymer is in the molten state. For example, the absorbing material may be added to the polymer during the thermal process of forming sheets.

After thorough blending and processing, followed by cooling, the hydrophilic agent forms interconnecting channels that act as transmission communicating passages throughout the polymer. In addition, the composition of the present invention is monolithic and the water-insoluble polymer, hydrophilic agent and absorbing material form a three phase system.

For purposes of the present invention, the term "phase" means a portion of a physical system that is uniform throughout, has defined boundaries and, in principle, can be separated physically from other phases. The term "interconnecting channels" means channels that penetrate through the water-insoluble polymer and that may be interconnected to each other. The term "water-insoluble polymer" means a polymer having a solubility in water below about 0.1% at 25°C and atmospheric pressure. The term "hydrophilic agent" is defined as a material that is not cross-linked and that has a solubility in water of at least about 1% at 25°C and atmospheric pressure. Suitable hydrophilic agents include "channeling" agents. The term "monolithic composition" means a composition that does not consist of two or more discrete macroscopic layers. Moreover, for

purposes of the present invention, the term "melting point" is defined as the first order transition point of the material determined by DSC. The term "not mutually soluble" means immiscible with each other.

In one embodiment, suitable hydrophilic agents of the present invention include polyglycols such as poly(ethylene glycol) and poly(propylene glycol) and mixtures thereof. Other suitable materials include EVOH, glycerin, pentaerithritol, PVOH, polyvinylpyrrolidone, vinylpyrrolidone or poly(N-methyl pyrrolidone), and saccharide based compounds such as glucose, fructose, and their alcohols, mannitol, dextrin, and hydrolyzed starch being suitable for the purposes of the present invention since they are hydrophilic compounds.

In another embodiment, suitable hydrophilic agents of the present invention may also include any hydrophilic material wherein, during processing, the hydrophilic agent is heated above its melt point upon melt mixing, and subsequently upon cooling separates from the polymer to form the interconnecting channeled structure of the present invention and a three phase system of a water-insoluble polymer, hydrophilic agent and an absorbing material.

Various types of absorbing material may be used with the present invention. In one embodiment, the absorbing material of the present invention includes a desiccating compounds. In general, there are three primary types of desiccating compounds that may be used with the present invention. The first type comprises chemical compounds that can combine with water to form hydrates. Examples of such desiccant are anhydrous salts which tend to absorb water or moisture and form a stable hydrate. In this reaction with the moisture, a stable compound is formed within which the moisture is held and prevented from release by chemical interaction.

The second type of desiccant compounds are those which are considered to be reactive. These compounds typically undergo a chemical reaction with water or moisture and form new compounds within which the water is combined. These newly formed compounds are generally irreversible at low temperature and require a significant amount of energy to be regenerated so that they may be reused as a desiccant. These reactive type desiccants are mainly used in solvent drying and as water-absorbing materials to polymers which must themselves be maintained in a moisture reduced state

The third type of desiccants obtain their moisture absorbing capabilities through physical absorption. The absorption process is accomplished because of a fine capillary

morphology of the desiccant particles which pulls moisture therethrough. The pore size of the capillaries, as well as the capillaries' density determine the absorption properties of the desiccant. Examples of these physical absorption desiccants include molecular sieves, silica gels, clays (e.g. montmorillinite clay), certain synthetic polymers (e.g. those used in baby diapers), and starches. Because these types of physical absorption desiccants are both inert and non-water soluble, they are preferred for many applications. In one embodiment, the molecular sieve pore sizes that are suitable for use in the present invention include between about 3 to 15 Angstroms; about 3 to 5 Angstroms, about 5 to 8.3 Angstroms; 4 Angstroms; 5 Angstroms; 8 Angstroms and 10 Angstroms. In another embodiment, the pore size of silica gel is about 24 Angstroms. Among other reasons, these innocuous characteristics are particularly compatible with food products and medicinal products that may be enclosed within containers formed from the desiccant entrained polymers, or at least exposed thereto. As stated previously, however, any of the three types may be employed within the polymers of the present invention for the purposes of producing a desiccant entrained polymer.

Suitable absorbing materials may also include: (1) metals and alloys such as, but not limited to, nickel, copper, aluminum, silicon, solder, silver, gold; (2) metal-plated particulate such as silver-plated copper, silver-plated nickel, silver-plated glass microspheres; (3) inorganics such as BaTiO_3 , SrTiO_3 , SiO_2 , Al_2O_3 , ZnO , TiO_2 , MnO , CuO , Sb_2O_3 , WC , fused silica, fumed silica, amorphous fused silica, sol-gel silica, sol-gel titanates, mixed titanates, ion exchange resins, lithium-containing ceramics, hollow glass microspheres; (4) carbon-based materials such as carbon, activated charcoal, carbon black, ketchem black, diamond powder; and (5) elastomers, such as polybutadiene, polysiloxane, and semi-metals, ceramic.

In another example, the absorbing material may be calcium oxide. In the presence of moisture and carbon dioxide, the calcium oxide is converted to calcium carbonate. Accordingly, calcium oxide may be used as the absorbing material in application where absorption of carbon dioxide is needed. Such applications include preserving fresh foods (e.g. fruits and vegetables) that give off carbon dioxide.

In one embodiment relating to absorbing material having a relatively fine particle size, many small interconnecting channels throughout the polymer should be produced, as opposed

to a few large interconnecting channels that will expose less surface area within the polymer. In one embodiment, dimer agents such as polypropylene maleic anhydride, or any plasticizer, may be optionally added to the mixture reducing viscosities and increasing the mixing compatibility of the polymer and hydrophilic agent.

In yet another embodiment, absorbing materials are selected having a polarity that causes an affinity between the absorbing materials and the hydrophilic agent. An example of such a polar desiccant is silica which is more compatible with the hydrophilic agent than it is typically with the water-insoluble polymer. For this reason, during the separating process when the interconnecting channels are formed throughout the polymer, it is believed that the absorbing material will congregate toward the hydrophilic agent domains to which it has a greater affinity. In this manner, it is theorized that the hydrophilic agent is permitted to act as a bridge between the vapor located exteriorly to the polymer structure and the absorbing material that is located within the polymer. This is particularly true with respect to absorbing material that is bound within the hydrophilic agent filled passages. In a further embodiment, polar plasticizers such as glycerin may be further added to the mixture which enhance the dispersion or mixing of the absorbing material into the hydrophilic agent.

It is believed that the higher the absorbing material concentration in the mixture, the greater the absorption capacity will be of the final composition. However, the higher absorbing material concentration should cause the body to be more brittle and the mixture to be more difficult to either thermally form, extrude or injection mold. In one embodiment, the absorbing material loading level can range from 10% to 20%, 20% to 40% and 40% to 60% by weight with respect to the polymer.

In one embodiment, the water-insoluble polymer of the present invention may be any thermoplastic material. Examples of suitable thermoplastic materials include polyolefins such as polypropylene and polyethylene, polyisoprene, polybutadiene, polybutene, polysiloxane, polycarbonates, polyamides, ethylene-vinyl acetate copolymers, ethylene-methacrylate copolymer, poly(vinyl chloride), polystyrene, polyesters, polyanhydrides, polyacrylonitrile, polysulfones, polyacrylic ester, acrylic, polyurethane and polyacetal, or copolymers or mixtures thereof.

In yet another embodiment, the components are first dry mixed in a mixer such as a Henschel, and then fed to a compounder. A Leistritz twin screw extruder, for example, or a

Werner Pfleider mixer can be used to achieve a good melt mix at about 140°C to about 170°C . The melt can then be either extruded to form, for example, a film or converted into pellets using dry air cooling on a vibrating conveyer. The formed pellets, containing channels, can, for example, then be either injection molded into beads, sieves, or co-injected with polypropylene as the inside layer of a container.

In yet a further another embodiment, because the composition of the present invention may typically be more brittle than the polymer without the absorbing material, the package may be molded so that an interior portion of the package is the composition of the present invention while the exterior portions are formed from pure polymer or the composition of the present invention with a lower absorbing material loading level. For example, a package having an interior portion composed of the composition of the present invention and an exterior portion composed of pure polymer typically will not only be more durable and less brittle, but it will also act as a vapor barrier that resists the transmission of the vapor from the exterior into the interior of the package. In this manner, the absorption capacity of the absorbing material agent is potentiated by exposing it exclusively to the interior of the package from which it is desired that the vapor be withdrawn and retained therefrom.

The composition of the present invention has numerous applications. One application is the construction of rigid containers that are suitable for containing relatively small volumes of product such as food stuffs and medicines. In many cases, these types of products must be shipped and stored in controlled environments (e.g. reduced moisture and/or oxygen). In another embodiment, the composition of the present invention may be formed into an insert for inclusion within the interior of the container. An example of one form of an insert is a plug of any suitable shape. While the plug would serve its purpose by being merely deposited within the container, it may also be fixed to an interior location so that it does not move about within the interior space. In a further embodiment, it is anticipated that a plug formed into a disc may be shaped and sized to be pressed fit into the bottom of a polymer formed container.

In another embodiment, a liner may be formed from the composition of the present invention that has an exterior surface substantially conforming to an interior surface of the container body. Like the disc, the liner may be sized so that it may be press-fit into position within the polymer body where it is held sufficiently snugly to prevent its unintended disengagement

therefrom. Alternatively, in a further embodiment, either the plug or liner may be initially constructed and allowed to harden, and then the container body subsequently constructed thereabout so that the greater shrinkage characteristics of the polymer body not containing absorbing material tightly shrink-fits the container body about the plug or liner so that neither becomes easily disengaged from the other. In still a further embodiment, the insert taking the form of either a plug or a liner may be substantially simultaneously comolded with the polymer container body so that each is integrally joined with the other. In the event of a co-molding process, the viscosities of the absorbing laden insert and the polymer container body should typically be approximately equal to facilitate the proper and desired location of the two phases of liquid or molten material that are molded together.

In yet another embodiment, composition of the present invention may be used to form sheeting that is joined with another sheet. In at least one embodiment, the sheets are effectively laminated one to the other so that an exterior layer may be established adjacent to the composition of the present invention which is substantially gas impermeable. The laminate sheet may then be used to wrap an item which is to be stored in a controlled environment. One means by which the joiner process may be accomplished is through a thermal extrusion procedure.

In each of the embodiments of the present invention described herein, advantages and enhancements over the prior art methods and structures stem from the discovery of the ability to create interconnecting channels throughout the composition of the present invention so that a rigid body may be constructed from the composition of the present invention while also exposing the water-absorbing material to the environment. Furthermore, the discovery of employing a hydrophilic agent that also acts as a transmission rate bridge between the exterior of the polymer body and the interiorly located absorbing material greatly enhances the structures' ability to quickly remove the desired property located exteriorly to the entrained structure, while at the same time taking advantage of a greater portion of the absorbing material's capacities.

One embodiment of the present invention includes a process for producing the composition of the present invention. In one embodiment, the process comprises blending a water-insoluble polymer and a hydrophilic agent. Either prior to blending the hydrophilic agent or after blending the hydrophilic agent, the absorbing material is blended into the polymer so that the additive is uniformly distributed within the polymer and the hydrophilic agent is distributed within

the polymer. Subsequently, after the composition is solidified, the result is that the hydrophilic agent forms interconnecting channels in the composition through which the desired property is transmitted through the polymer to the absorbing material within the composition. In another embodiment, the hydrophilic agent and absorbing material are all thoroughly mixed in dry powder form, and then the polymer blend is melted and formed into a desired shape by molding. Interconnecting channels are formed in the composition through which the desired property is transmitted through the polymer to the absorbing material within the composition.

In an alternative embodiment of the present invention, the monolithic composition comprising a water-insoluble polymer, a hydrophilic agent and an absorbing material may be made by first producing a two phase system comprising the water-insoluble polymer and the hydrophilic agent, then immersing the two phase system in a solution containing the absorbing material. As a result, the absorbing material is taken up by the composition and results in a monolithic composition consisting of at least three phases comprising the water-soluble polymer, the hydrophilic agent and the absorbing material. It is to be understood that, for purposes of the present invention, immersing includes soaking, coating or other methods that result in an uptake of the absorbing material by the composition.

One specific example consists of (1) mixing the water-insoluble polymer and the hydrophilic agent to produce a uniform blend; (2) heating the blend of step (1) to a temperature above the melting point of the hydrophilic agent; (3) cooling the blend of step (2) to form the desired shaped article; (4) immersing the shaped article of step (3) in a solution containing the absorbing material; (5) drying under suitable conditions that would not detrimentally affect the materials; and (6) forming a shaped article comprising a monolithic composition comprising the water-insoluble polymer; the hydrophilic agent and the absorbing material.

This alternative embodiment may be well-suited for materials that are heat-sensitive and thus, that may not be capable of withstanding the temperatures required to melt the hydrophilic agent during processing. An example of such high temperatures are the temperatures incurred during the extrusion step. Consequently, the absorbing material may be added downstream from the extrusion and thus, are not subject to higher temperatures, which may detrimentally effect the material. A further example of this alternative embodiment relates to producing the solution for the absorbing material. In one embodiment, an aqueous solution of the absorbing material is produced.

In yet another embodiment of the present invention, a water insoluble polymer such as polypropylene maleic anhydride may be combined with the hydrophilic agent without the third material (i.e. absorbing material). It is believed that, although this is only a two phase system, the maleic anhydride component of this composition would cause this composition to behave in a similar manner as the three phase system of the present invention (i.e. contain interconnecting channels). In addition, an absorbing material could also be added to this composition.

In a further embodiment, after the composition of the present invention is produced, some or all of the hydrophilic agent could be removed by conventional means (e.g. leaching). The resulting composition may then be capable of transmitting a higher amount of the desired gas or vapor through the composition. Alternatively, the resulting composition may then be immersed in a solution containing the desired material and further processed as desired above.

In an additional embodiment, a hydrophobic agent may replace some or all of the hydrophilic agent of the present invention.

For purposes of the present invention, the term "hydrophobic agent" is defined as a material that has a solubility in water of less than about 20% at 25°C and atmospheric pressure. Hydrophobic agents may be used in applications requiring the absorption of non-polar gases. For example, a water-insoluble polymer, a hydrophobic agent and an absorbing material of the present invention may be used in application where removal of toxic gases and/or organic solvents are required such as in filter systems. It is understood that, in some cases, the use of a hydrophobic agent in combination with the water-insoluble polymer and absorbing material may result in a two phase system.

In one embodiment, the composition of the present invention is used to form a plug for inclusion within a package constructed of a barrier substance. In another, the composition of the present invention is used to form a liner for inclusion within a container constructed from a barrier substance. In still another embodiment, the composition of the present invention is used to form an absorption sheet. The absorption sheet may optionally be combined with a barrier sheet constructed of a barrier substance for use as a packaging wrap. In another embodiment, the composition of the present invention is used to form an absorbing insert for a container.

Referring to figure 1 of the accompanying drawings of an embodiment of the present invention, an insert constructed from the composition of the present invention 20 is illustrated. For

purposes of this disclosure of the present invention, the words "entrain" and "contain" have been used interchangeably when referring to the inclusion of a desiccating agent 30 in a polymer 25 matrix. The insert is in the form of a plug 55 that may be deposited into a container body 60 (figure 5) thereby establishing an absorbing container 61 (figure 5). Referring to figure 2, a cross-sectional view is shown of the plug 55 that has been constructed from a polymer mixture comprising the water-insoluble polymer 25 that has been uniformly blended with the absorbing material 30 and the hydrophilic agent 35. In the illustration of figure 2, the composition of the present invention has been solidified so that interconnecting channels 45 have formed throughout the composition to establish passages throughout the solidified plug 55. As may be appreciated in both figures 1 and 2, the passages terminate in channel openings 48 at an exterior surface of the plug 55.

Figure 3 illustrates the embodiment of a plug 55 similar in construction and makeup to the plug 55 of figure 2, where interconnecting channels are very fine. This can result from the use of polyglycols as the hydrophilic agent, or the use of a dimer agent (i.e., a plasticizer) together with a hydrophilic agent. The dimer agent 50 may enhance the compatibility between the polymer 25 and the hydrophilic agent 35. This enhanced compatibility is facilitated by a lowered viscosity of the blend which should promote a more thorough blending of the two compounds 25,35 which resists combination into a uniform solution. Upon solidification of the composition of the present invention that has had a dimer agent added thereto, the interconnecting channels which are formed therethrough have a greater dispersion and a smaller porosity thereby establishing a greater density of interconnecting channels throughout the plug 55. In one embodiment, this same effect occurs readily when a polyglycol is used as the hydrophilic agent due to the general comparability of polyglycols with hydrophobic thermoplastics such as polyolefins. The interconnecting channels are created to provide pathways for controlled transmission of the desired property (e.g. gas) from the exterior of the solidified plug 55 to interior locations where the entrained water-absorbing material 30 is bound.

It is believed that these interconnecting channels are required because of the hydrophobic characteristics of the polymer 25 that resist gas permeability therethrough and therefore acts as a gas barrier. For this reason, the polymer 25 itself is referred to as a barrier substance within which an absorbing material 30 may be entrained. To expose the absorbing material 30 entrained within the interior of the polymer 25, however, the interconnecting channels

45 are provided. Without these interconnecting channels 45, it is believed that relatively small quantities of gas would be absorbed by the entrained absorbing material 30. It is further believed that these small amounts derive from the limited number of absorbing particles 30 that would be exposed at the exterior surface of the formed body and the very small amounts of gas that would be able to pass through the substantially impermeable polymer 25. Because of these characteristics, the water-insoluble polymer 25 is referred to as a barrier even though it may not be completely impermeable to gas.

Figure 3 illustrates an embodiment of the present invention of a plug 55 which has been deposited into a container body 60 thereby establishing an absorbing container 61. The container body 60 has an interior surface 65 and is constructed substantially from the composition of the present invention. In this manner, the transmission property is resisted from being transmitted across a wall of the container 60 when the container 60 is closed. As may be seen in figure 3, the plug 55 has been press fit into a bottom location of the container 60. It is contemplated that the plug 55 may be merely deposited in the container 60 for loose containment therein, but it is preferable coupled to the body of the container 60 in a manner that fixes the plug 55 to the container 60. The couple between the plug 55 and the container body 60 is intended to prevent the dislocation and relative movement of the plug 55 thereabout. This connection may be accomplished by a snug press fit between the plug 55 and the interior surface 65 of the body 60, or it may be mechanically connected in such manners as adhesives, prongs, lips or ridges that extend about the plug 55 to hold the plug 55 in place. In yet another embodiment, it is contemplated that the container body 60 may be molded about the plug 55 so that during the curing process of the container body 60 the body 60 shrinks about the plug 55 thereby causing a shrink-fit to be established between the two components. This type of complement may also be accomplished in a comolding process or sequential molding process with the same results achieved because the plug 55 will have less shrinkage than the polymer 25 comprised container body 60.

Figure 4 illustrates an absorbing container 61 having the composition of the present invention formed of a plug 55 located at a bottom location of the container 60 similar to the configuration illustrated in figure 3, but the plug 55 and container body 60 are comolded so that a unified body 61 is formed with a less distinct interface between the plug 55 and body 60 components.

Figures 5 and 6 illustrate concepts similar to those of figures 3 and 4, however the proportions of the plug 55 have been extended so that a liner 70 is formed which covers a greater portion of the interior surface 65 of the desiccating container 61. The liner 70 is not localized in the bottom portion of the container body 60, but has walls which extend upwardly and cover portions of the walls of the container 61. Like the plug 55, the liner 70 may be separately molded and subsequently combined with the container body 60 or it may be comolded therewith into the unified body illustrated in figure 6.

Figures 7 and 8 illustrate an embodiment of the invention in which an absorbing sheet of the present invention 75 is created for combination with a barrier sheet 80. The characteristics of the sheets are similar to those described with respect to the plug 55 and liner 70 and container body 60. That is, figure 7 illustrates an embodiment in which the two sheets 75, 80 are separately molded, and later combined to form a packaging wrap having an absorbing characteristics at an interior surface and vapor resistant characteristics at an exterior surface. Figure 8 illustrates a comolded process wherein an interface between the absorbing sheet 75 and the barrier sheet 80 is less distinct than in the embodiment of figure 7. This product can be produced by a thermal, forming process. In such a process, the polymer layer is melted and partially formed into a sheet with the desiccant 30 being deposited on top of that layer just prior to being pressed or extruded through a slit like opening in the thermal forming machine. It is contemplated that the separate sheets 75, 80 of figure 7 may be joined together with an adhesive or other suitable means to form a laminate from the plurality of sheets 75, 80. Alternatively, the sheeting 75, 80 may be manufactured from a thermal extrusion process whereby both sheets 75, 80 are manufactured at the same time and effectively comolded together to form the embodiment illustrated in figure 8.

In a further embodiment of the present invention, a plug 55 is formed from the mixture for inclusion within a container 60 that is constructed from a barrier substance. In one embodiment, the plug 55 is deposited into a container 60 that is constructed from a barrier substance. In this manner, a desiccating container 61 is created. The plug 55 may be coupled to an interior surface of the container body 60 so that the plug 55 is fixed relative to the container 60.

Alternatively, a container 60 constructed from a barrier substance may be molded about the plug 55 so that at least a portion of the plug 55 is exposed to an interior of the container 60. A desiccating plug 55 made according to the present invention may also be co-molded with a

container 60 that is constructed from a barrier substance so that at least a portion of the plug 55 is exposed to an interior of the container 60.

In another embodiment, a liner 70 may be formed from the mixture 40 and then be included within a container 60 constructed from a barrier substance. The liner 70 typically, but not necessarily, has an exterior surface configured for mating engagement with an interior surface 65 of the container 60. The liner 70 may be pressed into mating engagement with the container 60 so that a container 61 is created wherein at least a majority of the interior surface 65 of the container is covered by the liner 70. The liner 70 may be formed from the mixture 40 and then a container 60 constructed from a barrier substance may be molded about the liner 70 so that at least a portion of the liner 70 is exposed to an interior of the container 60 and a majority of an interior surface 65 of the container 60 is covered by the liner 70.

Alternatively, the liner 70 and container body 60 may be comolded together into a unified body. The absorbing sheet 75 is combined with a barrier sheet 80 that is constructed of a barrier substance for use as a packaging wrap. The sheets 75, 80 may be laminated by thermal extrusion.

A dimer agent may optionally be added to the mixture to increase the mixing compatibility of the polymer 25 and the channeling agent 35 thereby increasing the dispersion of the passages within the solidified mixture.

In still another embodiment of the present invention, a method for making an absorbing container 61 is provided. The method includes forming a container 60 from substantially gas impermeable material so that a gas barrier is created between an interior and exterior of the container. An insert is formed from composition of the present invention. The insert has an exterior surface that is configured for mating engagement with at least a portion of an interior surface 65 of the container 60. The insert is installed into the interior of the container 60 so that at least a portion of the exterior surface of the insert abuttingly engages the interior surface 65 of the container 60. The engagement fixes the insert relative to the container 60 and resists disengagement of the insert from the container 60. The insert is exposed to the interior of the container 60 for absorbing the desired property. The insert is pressed into the interior of the container 60 with sufficient force that the insert fits tightly within the container 60 thereby resisting disengagement therefrom. The insert is sized and shaped so that the insert fits snugly into a receiving location within the interior of the

container for retention at the receiving location.

In another embodiment, the insert is sized and shaped into a plug 55 that fits snugly into a receiving location at a bottom portion of the interior of the container 60 for retention at the receiving location.

In a further embodiment, the insert is configured into a liner 70 having an exterior surface that conforms to the interior surface 65 of the container 60 so that a majority of the liner's 70 exterior surface is in abutting engagement with the container's 60 interior surface 65. The container 60 and the liner 70 are similarly configured so that the interior 65 of the container 60 and the exterior of the liner 70 fit snugly together so that disengagement of the liner 70 from the container 60 is resisted.

In another example, the container 60 may be molded from a plastic that is substantially gas impermeable and therefore resists the transmission of gas across the boundary of the container 60 between its exterior and its interior. Also, the liner 70 may be molded from the composition of the present invention.

In yet another embodiment, a method for making an absorbing container 61 is provided. A container is formed from substantially air and moisture impermeable material so that a barrier is established between an interior and exterior of the container 60. A substantially solid tablet or plug 55 is formed from the composition of the present invention 20, the tablet 55 being suitably sized to fit within the interior of the container 60. The tablet 55 is then deposited into the interior of the container 60 thereby establishing a means for absorbing the desired material from the interior of the container 60 when the container 60 is closed about the tablet 55.

In another embodiment of the present invention, a method for making an absorbing packaging is provided. An outer skin, sheet, or layer 80 is formed from a substantially air and moisture impermeable sheet of material so that a barrier is created between opposite sides of the skin. An inner skin, sheet, or layer 75 is formed from the composition of the present invention 20 at one side of the outer skin 80. An absorbing package is formed about a product or item by sealing the product or item within the outer impermeable skin 80 and with the inner absorbing skin 75 located adjacent to the product. An absorbing laminate may be formed by suction vacuum molding the outer skin 80 and the inner skin 75 together to form absorbing packaging.

In one embodiment of the present invention, an absorbing enclosure 61 is provided.

The enclosure includes a container 60 formed from substantially moisture and air impermeable material so that a barrier is created between an interior and exterior of the container 60. A liner 70 is formed from the composition of the present invention 20 so that the liner 70 has an exterior surface configured for mating engagement with at least a portion of an interior surface 65 of the container 60. The liner 70 is inserted into the interior of the container 60 so that at least a portion of the exterior surface of the liner abuttingly engages the interior surface 65 of the container 60. The engagement fixes the liner 70 relative to the container 60 and resists disengagement of the liner 70 from the container 60.

In another embodiment of the present invention, an absorbing insert for a closeable container 60 includes an absorbing insert configured for installation into a closeable container 60. The insert 25 is constructed from the composition of the present invention. The insert 25 has passages extending from its exterior surface into its interior.

The present invention will be illustrated in greater detail by the following specific examples. It is understood that these examples are given by way of illustration and are not meant to limit the disclosure or claims. For example, although the following examples were tested at 10% Rh and 20% Rh at 72°F, the composition of the present invention is also suited for other conditions. Moreover, these examples are meant to further demonstrate that the present invention has interconnecting channels and that the hydrophilic agents reside in the interconnecting channels. All percentages in the examples or elsewhere in the specification are by weight unless otherwise specified.

EXAMPLE 1

The purpose of the following example is to demonstrate that the composition of the present invention has interconnecting channels by subjecting the following materials to a swelling and weight loss analysis.

A. Preparation of Samples

Film #1: A blend of about 93% (w/w) of polypropylene (Exxon Chemicals, tradename Escorene® polypropylene 3505G) and about 7% (w/w) of poly(ethylene glycol) (Dow Chemical, tradename E-4500) was sufficiently mixed to produce a uniform blend. The blend was then fed through a Leistritz twin screw extruder at temperatures in the sixteen zones ranging from about 145°C to about 165°C, at a feed rate of about 40 lbs/hr, at a screw speed of about 460 rpm and

a six inch die. The extruded composition was then fed through a three roll hot press at temperatures ranging from about 85°C to about 92°C to produce a film of about 4 mil.

Film #2: A blend of about 68% (w/w) of polypropylene (Exxon Chemicals, tradename Escorene® polypropylene 3505G) and about 3505G), about 12% (w/w) of poly(ethylene glycol) (Dow Chemical, tradename E-4500) and about 20% (w/w) of a desiccant of molecular sieve (Elf Atochem, tradename Siliporite® molecular sieve, 4 Angstrom) was sufficiently mixed to produce a uniform blend. The blend was then fed through a Leistritz twin screw extruder at temperatures in the sixteen zones ranging from about 145°C to about 165°C, at a feed rate of about 40 lbs/hr at a screw speed of about 460 rpm and a six inch die. The extruded composition was then fed through a three roll hot press at temperatures ranging from about 85°C to about 92°C to produce a film of about 4 mil.

Film #3: A blend of about 34.88% (w/w) of polypropylene (Exxon Chemical, tradename Escorene® polypropylene 3505G), about 11.96% (w/w) of poly(ethylene glycol) (Dow Chemical, tradename E-4500), about 52.82% (w/w) of a desiccant of molecular sieve (Elf Atochem, tradename Siliporite® molecular sieve, 4 Angstrom) and about 0.34 % (w/w) of a grey colorant was sufficiently mixed to produce a uniform blend. The blend was then fed through a Leistritz twin screw extruder at temperatures in the sixteen zones ranging from about 145°C to about 165°C, at a feed rate of about 50 lbs/hr at a screw speed of about 460 rpm and a six inch die. The extruded composition was then fed through a three roll hot press at temperatures ranging from about 85°C to about 92°C to produce a film of about 4 mil.

B. Swelling And Weight Loss Analysis

Circular disks (OD 1.1 cm) were cut from each of the three samples. Initial dry weights of each sample was recorded. Samples were subsequently incubated in 2.0 ml distilled water and left shaking at room temperature. Periodically at 1, 2, 3, and 34 days, the disks were removed, the surface blotted dry and the sample weighed, to determine the extent of swelling. At each timepoint, the distilled water was replaced to provide for sink conditions. At the end of the study, the samples were lyophilized to remove the water and the sample weighed to determine mass loss. Figure 9 is a graph of the result of the analysis. Percent swelling is defined as the wet weight at a time point (t), divided by initial dry weight (zero) and multiplied by 100. 'Dry' indicates the final lyophilized sample weight following the 34 day incubation.

Figure 9 shows film #1 did not swell or lose weight over the course of 34 days. Thus, it is believed that this result shows that the poly(ethylene glycol) (i.e., hydrophilic agent) was completely entrapped in the polypropylene (i.e., water-insoluble polymer). Film #2 gained approximately 3% of its initial weight by swelling and lost approximately 9% of its initial weight at the end of the 34 days of incubation. Film #3 gained approximately 6% of its initial weight and lost approximately 8% of its initial weight at the end of the 34 day incubation period. These results demonstrate that interconnecting channels from the exterior through the interior exist in the composition of the present invention because water penetrated films #2 and #3 and a substantial portion of the water soluble component (e.g., poly(ethylene glycol)) of films #2 and #3 was extracted from the polymer.

EXAMPLE 2

The purpose of the following example is to demonstrate that the composition of the present invention has two separate phases consisting of a water-insoluble polymer and a hydrophilic agent.

A. Preparation Of Samples

Film #4: 100% polypropylene (Exxon Chemicals, tradename Escorene® polypropylene 3505G) was fed through a Leistritz twin screw extruder at temperatures in the sixteen zones ranging from about 145°C to about 165°C, at a feed rate of about 40 lbs/hr, at a screw speed of about 460 rpm and a six inch die. The extruded composition was then fed through a three roll hot press at temperatures ranging from about 85°C to about 92°C to produce a film of about 4 mil.

Film #5: A blend of about 88% (w/w) of polypropylene (Exxon Chemicals tradename Escorene® polypropylene 3505G), about 12% (w/w) of poly(ethylene glycol) (Dow Chemical, tradename E-4500) was sufficiently mixed to produce a uniform blend. The blend was then fed through a Leistritz twin screw extruder at temperatures in the sixteen zones ranging from about 145°C to about 165°C, at a feed rate of about 40 lbs/hr, at a screw speed of about 460 rpm and a six inch die. The extruded composition was then fed through a three roll hot press at temperatures ranging from about 85°C to about 92°C to produce a film of about 4 mil.

Film #7: A blend of about 68% (w/w) of polypropylene (Exxon Chemicals, tradename Escorene® polypropylene 3505G), about 12% (w/w) of poly(ethylene glycol) (Dow Chemical, tradename E-4500) and about 20% (w/w) of a desiccant of molecular sieve (Elf Atochem,

tradename Siliporite® molecular sieve, 4 Angstrom) was sufficiently mixed to produce a uniform blend. The blend was then fed through a Leistritz twin screw extruder at temperatures in the sixteen zones ranging from about 145°C to about 165°C, at a feed rate of about 12 lbs/hr, at a screw speed of about 460 rpm and a six inch die. The extruded composition was then fed through a three roll hot press at temperatures of about 105°C to produce a film of about 4 mil.

B. Thermal Analysis Using Differential Scanning Calorimetry ("DSC")

The processed film samples were analyzed using a Perkin Elmer DSC7 equipped with a TAC 7DX thermal controller. Data were analyzed using Perkin Elmer Pyris software (version 2.01). Samples were heated from -50 to 250°C at a rate of 10 or 15 °C/min, then cooled at the same rate and then heated once again to 250°C at the same rate. The following table is the data collected from the DSC. The melting point data is given as the melting point peak (°C) and enthalpy (ΔH , joules/gm) for the first heating ramp (1°) and the second heating ramp (2°). The column referring to Figures 10 through 18 is the graphical output from the DSC that corresponds to the data from the table. Since the samples are only heated to 250°C, the molecular sieve in film samples #2, #3 and #7 was not melted and thus, no melting point data was recorded.

<u>Sample</u>	<u>Figure #</u>	<u>PEG Peak °C</u>	<u>PEG ΔH J/g</u>	<u>PP Peak °C</u>	<u>PP ΔH J/g</u>
100% poly(ethylene glycol)	FIG 10	1° 63.808	190.362	none	none
Film #4	FIG 11	1° none 2° none	none none	162.700 157.200	78.462 96.123
Film #5	FIG 12	1° 57.700 2° 58.033	22.253 20.361	161.700 157.366	80.524 79.721
Film #6	FIG 13	1° none 2° none	none none	159.366 160.033	42.385 42.876
Film #7	FIG 14	1° 56.366 2° 57.200	19.460 17.094	162.200 156.866	70.073 58.038
Film #2 [pre-incubation]	FIG 15	1° 58.554 2° 58.779	20.845 16.037	163.062 157.783	60.577 53.706
Film #2 [post-incubation]	FIG 16	1° 55.804 2° 57.529	0.379 0.464	163.062 158.533	86.215 67.949
Film #3 [pre-incubation]	FIG 17	1° 59.308 2° 56.529	18.849 10.122	162.562 158.283	40.291 24.980
Film #3 [post-incubation]	FIG 18	1° 55.554 2° none	0.138 none	160.562 156.033	46.931 26.081

The 100% poly(ethylene glycol) sample, exhibits a single melting point at 63 °C while film #4 100% polypropylene has a melting point at 157 °C. Film #5 displayed both peaks at 58 °C (poly(ethylene glycol)) and 157°C (polypropylene), which indicates that the two polymers were phase separated. If the polymers were not phase separated but mixed, then the peaks would not be at the melt temperatures of the pure polymers, but shifted. Film #6 shows only the distinct polypropylene peak at 160°C. The molecular sieves do not melt in this temperature range or affect the melting temperature of pure polypropylene. Film #7 again shows two distinct peaks: one for poly(ethylene glycol) at 57 °C and one for polypropylene at 157°C indicating that in the three component mixture, all are phase separated.

Film samples #2 and 3 were part of the swelling and weight loss analysis presented in Example 1. Once again two distinct peaks were evident: one for poly(ethylene glycol) at 59 °C and one for polypropylene at 158°C indicating that in the three component mixture, all components

were phase separated. However when the polymer film was incubated in water for 34 days at room temperature (File #2: post-incubation) and tested by DSC, the positions of the peaks remained the same indicating the components were still phase-separated. However the area of the poly(ethylene glycol) peak (indicated by ΔH , enthalpy) was greatly reduced. This result indicated that poly(ethylene glycol) had been extracted by the prolonged water incubation. Also, the result provided further confirmation for the weight loss data presented in Example 1 and demonstrated that the poly(ethylene glycol) component was mostly extracted by means of interconnecting channels in the bulk polypropylene matrix.

Film sample #3 showed the same effect as Film sample #2. The polypropylene ΔH peak was not detectable (Film #3: post-incubation), demonstrating nearly complete extraction of poly(ethylene glycol) during water incubation. This confirmed the weight loss result of Example 1 in which the same film lost approximately 8% of its initial weight. The poly(ethylene glycol) composition of the sample was approximately 12% (w/w).

In addition, the glass transition (T_g) analysis from the DSC data of the samples of the present invention also demonstrate that the water-insoluble polymer and the material exist in separate phases. Pure polypropylene exhibits a T_g of about -6°C while pure poly(ethylene glycol) exhibits a T_g at about -30°C . DSC data from film #5 exhibit two distinct T_g 's, which correspond to the respective polymers (6°C for polypropylene and -30°C for poly(ethylene glycol) and thus, indicates, further that the two components are phase separated.

EXAMPLE 3

The purpose of the following example is to demonstrate that the composition of the present invention has interconnection channels and has the water absorbing material intermixed within the hydrophilic agent.

A. Scanning Electron Microscopy ("SEM") Method

The structural properties of the films was imaged using a Hitachi S-2700 microscope operating at 8 kV accelerating voltage to minimize irradiation damage. Each film sample was visualized in three perspectives: 1) the film surface; 2) the fractured film cross-section (0°) and 3) the fractured film cross-section at a 90° angle with respect to orientation #2 (90°). Pre-incubation film samples were directly sputter coated with a 5-10 nm layer of gold-palladium with a Polaron Instruments Sputter Coater E5100. Post-incubation samples were incubated at room temperature

for 24 hrs in 10 ml of 70% ethanol (w/v) with agitation. The ethanol was discarded and the samples were air-dried overnight. Samples were then frozen and lyophilized overnight to remove any residual moisture and then sputter coated.

B. Morphology of Film Samples:

Figures 19a-c are scanning electron photomicrographs of film sample #4 -- 100% polypropylene. Figures 19a-c illustrate that a water-insoluble polymer is typically a dense, homogenous morphology with substantially no porosity. The outer surface is shown in Figure 19a. Figure 19a shows an outer surface that is dense and displaying substantially no porosity. The cross-sectional view is shown in Figure 19b at a magnification of 200 times. Figure 19b shows plate-like domains of polymer that were revealed during brittle fracture of the film. Another cross-sectional view is shown in Figure 19c at a magnification of 1000 times. Figure 19c shows a dense, fibrillar morphology.

Figures 20a-c are scanning electron photomicrographs of film samples #5 -- about 88% polypropylene and 12% poly(ethylene glycol). Figures 20a-c illustrate that a two phase system consisting essentially of a water-insoluble polymer and hydrophilic agent has a heterogeneous morphology with dense fibrillar matrix interspersed with domains of lamellar structures, which is the poly(ethylene glycol). Figures 20a-c further show voids between lamellar fibrillar and fibrillar structures that are channels and are oriented in the same direction. The outer surface is shown in Figure 20a at a magnification of 1000 times. Figure 20a shows an outer surface that is dense and displaying substantially no porosity. The cross-sectional view is shown in Figure 20b at a magnification of 2,500 times. Figure 20b shows fibrillar domains of polymer coated with lamellar strands of poly(ethylene glycol). Figure 20c is a cross-sectional view of film sample #5 fractured at a perpendicular angle and at a magnification of 1,500 times. Figure 20c shows the fibrillar polypropylene matrix interspersed with solid, amorphous cylinder of poly(ethylene glycol).

Figures 21a-c are scanning electron photomicrographs of film sample #6 -- about 50% polypropylene and 50% molecular sieve. Figures 21a-c illustrate a typically homogeneous dense matrix and discrete molecular sieves can only occasionally be seen and are deeply embedded in the polymer despite the high loading of molecular sieves. Figure 21a shows the outer surface at a magnification of 1,000 times that is covered with long channels measuring 5-30 microns. The outline of the molecular sieves (1-10 microns) can be seen embedded beneath the surface of the

polymer. The cross-sectional view is shown in Figure 21b at a magnification of 200 times. Figure 21b shows plate-like domains of polymer and a grainy appearance due to the high loading of molecular sieves. Figure 21c is a cross-sectional view at a magnification 1,500 times and shows a dense morphology, substantially no porosity and many small particles embedded in the polymer.

Figures 22a-d are scanning electron photomicrographs of film samples #3 -- about 52% molecular sieve, about 34% polypropylene and about 12% poly(ethylene glycol). Figures 22a-d show a three phase system with a highly porous morphology. Figure 22a shows the outer surface at a magnification of 500 times that is covered with long channels, measuring 5-30 microns, and that is filled with numerous discrete molecular sieve particles. A cross-sectional view is shown in Figure 22b at a magnification of 350 times. Figure 22b shows a very porous morphology with long channels running in the fracture orientation. Figure 22c is a cross-sectional view in the perpendicular orientation at a magnification of 350 times and appears to show holes. Figure 22 is at higher magnifications -- 1,500 times. Figure 22d shows channels containing discrete molecular sieves as well as agglomerates of many sieves embedded in the poly(ethylene glycol). Consequently, based on Figure 22b, it is believed that the holes seen in Figures 22b and 22c are locations where the molecular sieve fell out during fracture preparation for SEM.

In conclusion, Examples 1, 2 and 3 further confirm the theory for the formation of interconnecting channels. Since, in one embodiment, the process begins at a temperature at which the hydrophilic agent is in molten form while the water-insoluble polymer is in solid form, it is believed that the third component (e.g. molecular sieve) is interacting with the liquid hydrophilic agent. Consequently, it is believed that, at this point, the interconnecting channels are formed because the hydrophilic agent flows easily and fills the gaps between the solid water-insoluble polymer and the molecular sieve components. As the process continues and the temperature increases, the water-insoluble polymer melts and thus, the composition becomes more uniform.

EXAMPLE 4

The purpose of the following example is to demonstrate the water absorption properties of the compositions of the present invention. Samples of film with similar processing conditions as film #1 were having about 50% (w/w) of molecular sieve [4 Angstrom], about 12% (w/w) poly(ethylene glycol) and about 38% (w/w) polypropylene and were evaluated for moisture adsorption of its total weight by using the following test method (a) one environmental chamber was

preset for 72°F and 10% relative humidity ("Rh") and another chamber was preset for 72°F and 20% Rh; (b) the dish was weighed and the weight recorded; (c) the scale was then tared to remove the weight of the dish from the balance; (d) the film was then added to the weighed dish; (e) the material was then weighed and the weight recorded; (f) the weigh dish with the sample was placed in the environmental chamber; (g) the sample was left in the chamber for the desired time; (h) after the desired time was reached, the dish with the sample was removed, re-weighed and the weight recorded; and (i) the percent moisture gained per gram of molecular sieve was calculated by $(\text{total weight gain of sample})/(\text{weight of molecular sieve in sample}) \times 100$. The results are presented in Figures 23a [10% RH] and 23b [20% Rh]. The maximum theoretical percent moisture gained per weight of a 4 Angstrom molecular sieve is about 24 to 25%. Figures 23a and 23b demonstrate that the high transmission rate (e.g., moisture absorption rate) of the present invention.

Monolithic compositions and their constituent compounds have been described herein. As previously stated, detailed embodiments of the present invention are disclosed herein; however, it is to be understood that the disclosed embodiments are merely exemplary of the invention that may be embodied in various forms. It will be appreciated that many modifications and other variations that will be appreciated by those skilled in the art are within the intended scope of this invention as claimed below without departing from the teachings, spirit and intended scope of the invention.

What is claimed is:

1. A monolithic composition formed by combining components comprising:
 - (a) a water-insoluble polymer;
 - (b) a hydrophilic agent wherein, during processing, is heated above its melting point; and
 - (c) an absorbing material.
2. A monolithic composition comprising:
 - (a) a water-insoluble polymer;
 - (b) a hydrophilic agent wherein, during processing, is heated above its melting point; and
 - (c) an absorbing material.
3. A monolithic composition formed by combining components comprising:
 - (a) a water-insoluble polymer;
 - (b) a hydrophilic agent wherein, during processing, is heated above its melting point; and
 - (c) an absorbing material,wherein the combination of components after mixing forms a composition consisting of at least three phases.
4. A monolithic composition comprising:
 - (a) a water-insoluble polymer;
 - (b) a hydrophilic agent wherein, during processing, is heated above its melting point; and
 - (c) an absorbing material,wherein the combination of components after mixing forms a composition consisting of at least three phases.
5. A monolithic composition formed by combining components comprising:
 - (a) a water-insoluble polymer;
 - (b) an organic hydrophilic agent; and
 - (c) an absorbing material

wherein the combination of components after mixing forms a composition consisting of at least three phases.

6. A monolithic composition formed by the following steps comprising:
 - (a) combining a water-insoluble polymer and an hydrophilic agent wherein the polymer and agent are not mutually soluble;
 - (b) mixing of the polymer and the agent;
 - (c) heating the polymer and agent mixture above the melting point of the agent;
 - (d) adding an absorbing material;
 - (e) mixing the components of step (d);
 - (f) cooling the composition.
7. The process of claim 1, wherein the water-insoluble polymer is selected from the group consisting of polyolefins, polycarbonates and polyamides.
8. The process of claim 4, wherein the water-insoluble polymer is selected from the group consisting of polyolefins, polycarbonates and polyamides.
9. The process of claim 1, wherein the hydrophilic agent is selected from the group consisting of polyglycols, poly(ethylene vinyl alcohols), glycerin and polyvinyl alcohol.
10. The process of claim 4, wherein the hydrophilic agent is selected from the group consisting of polyglycols, poly(ethylene vinyl alcohol), glyceria and polyvinyl alcohol.
11. The process of claim 1, wherein the shaped article is selected from the group consisting of sheets, films, pellets and beads.
12. The process of claim 4, wherein the shaped article is selected from the group consisting of sheets, films, pellets and beads.

FIG. 1

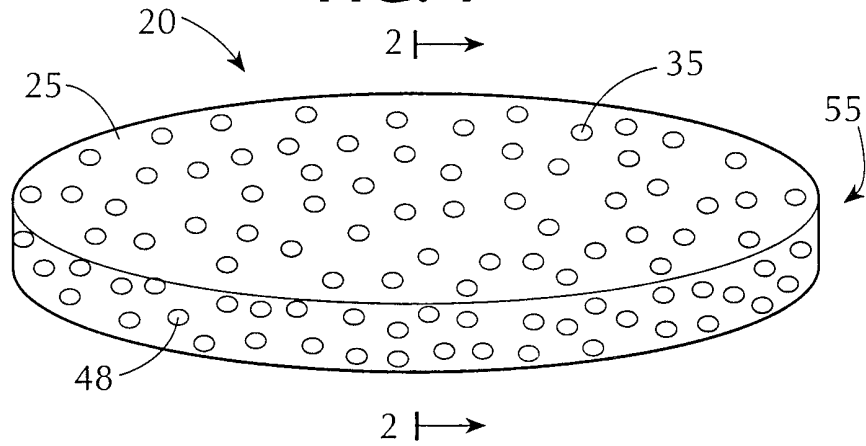

FIG. 2

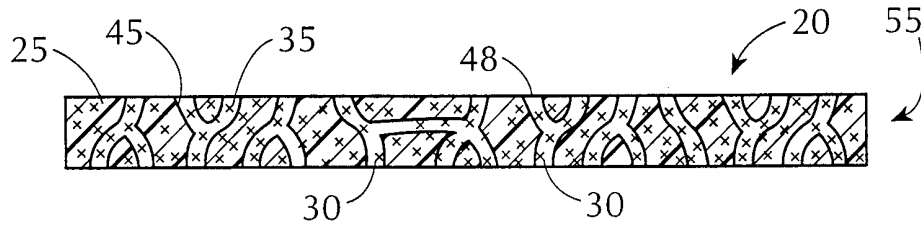

FIG. 3

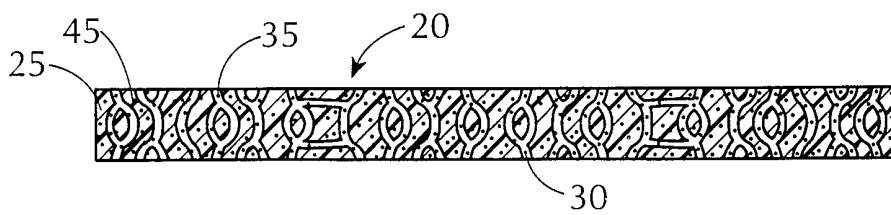

FIG. 4

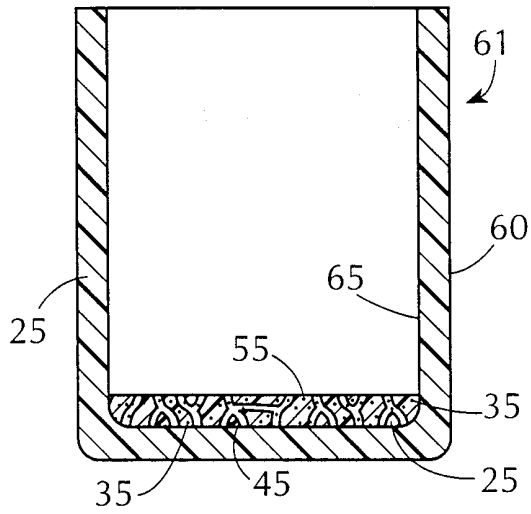

FIG. 5

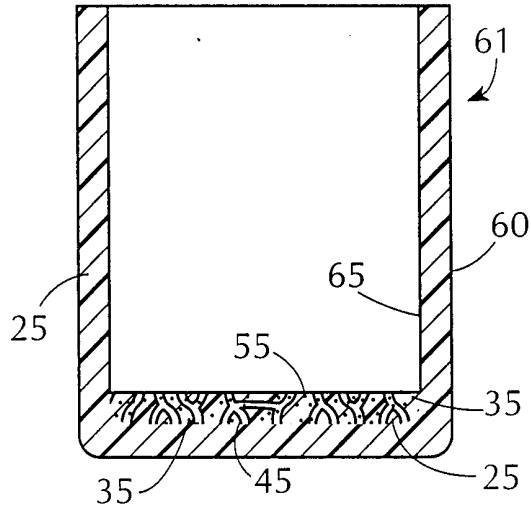

FIG. 6

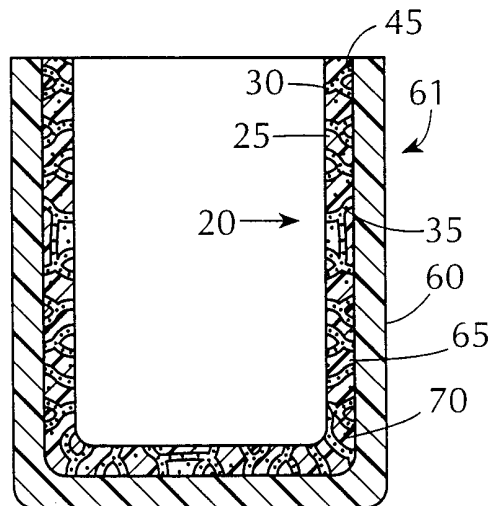

FIG. 7

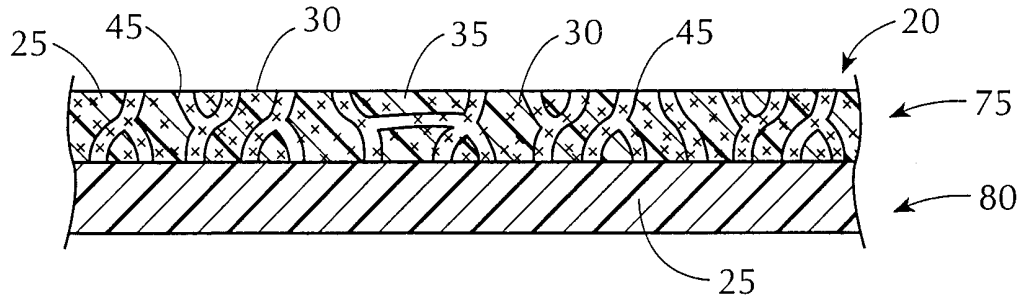
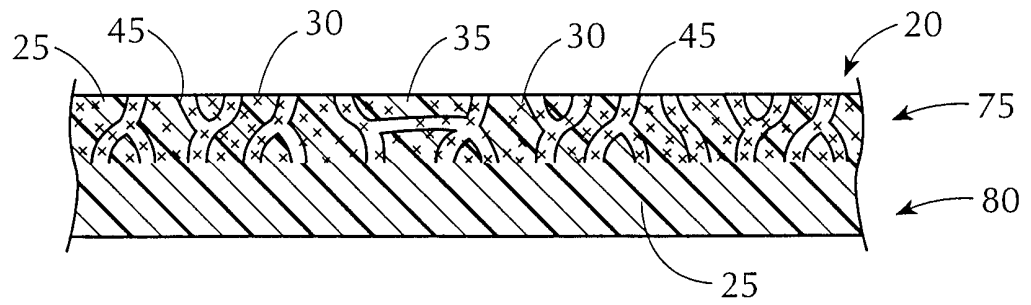

FIG. 8



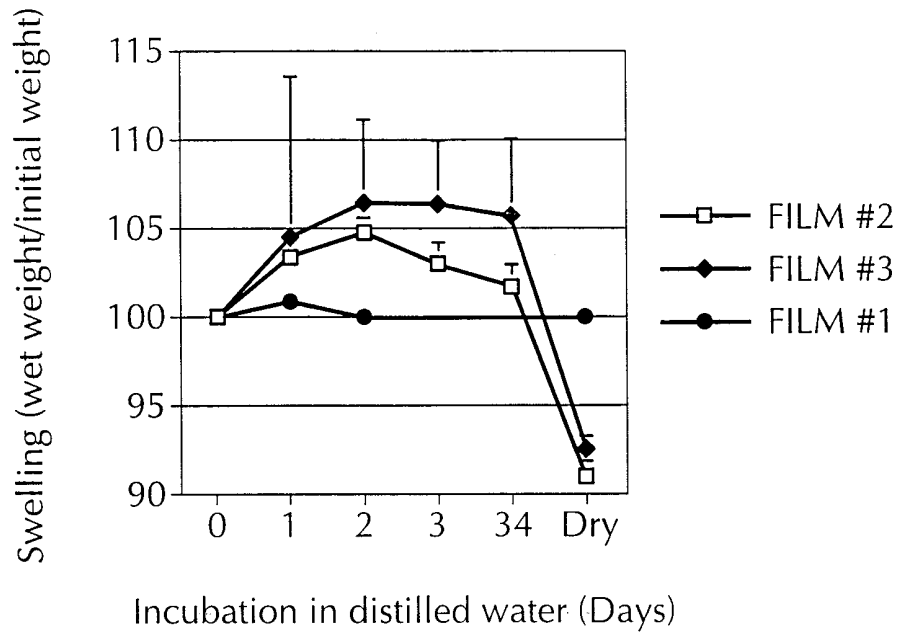

FIG. 9

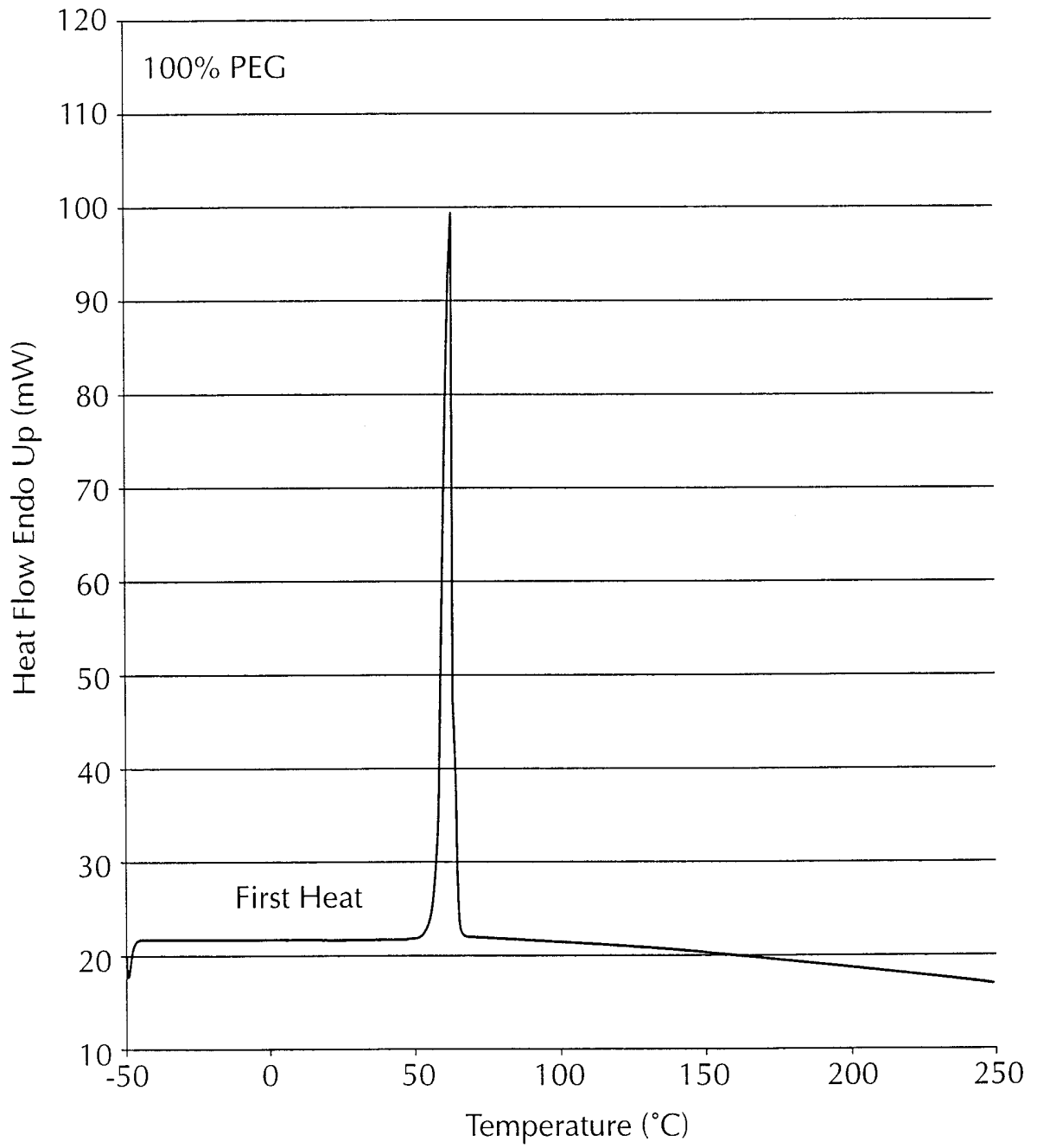

FIG. 10

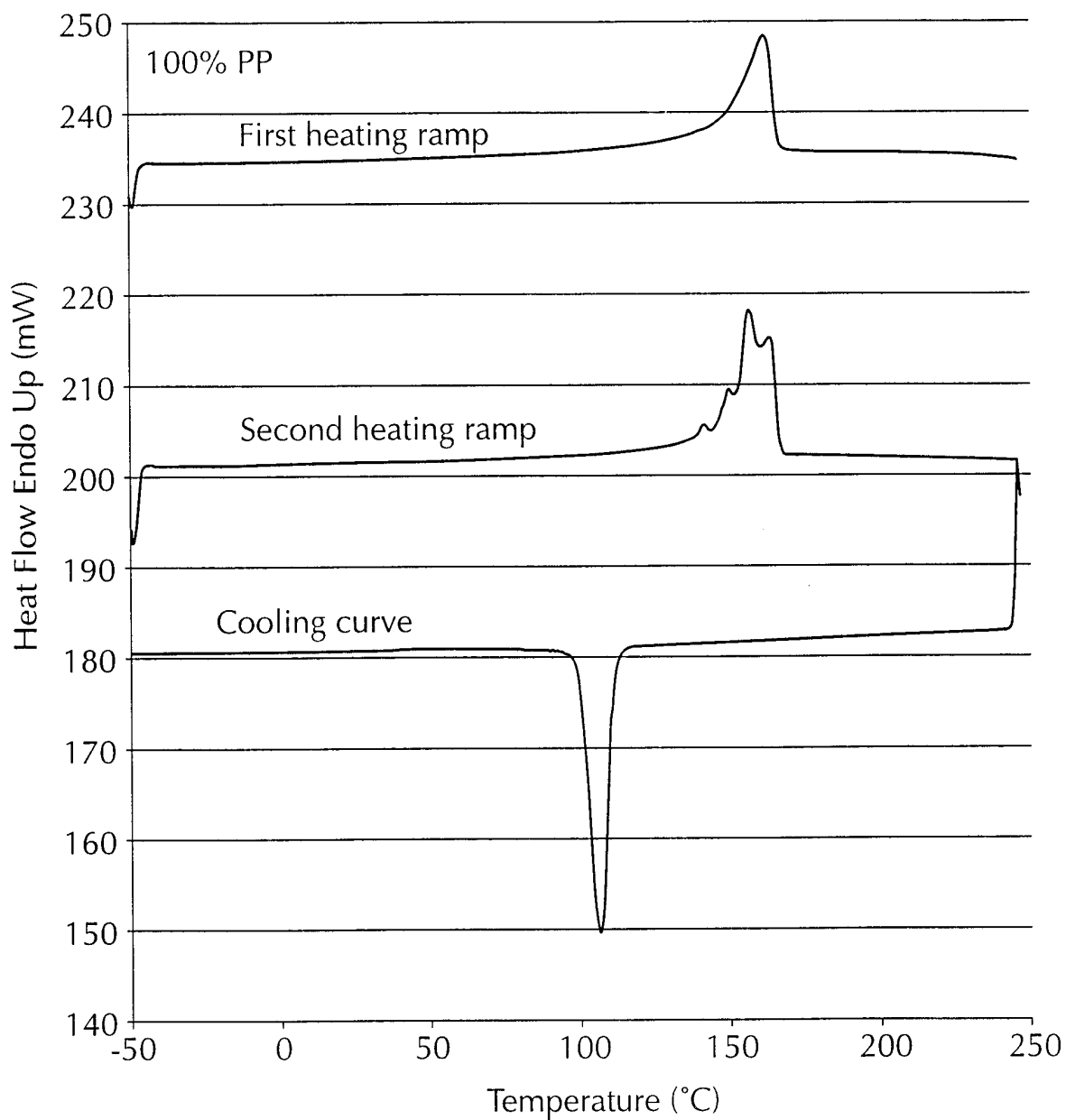

FIG. 11

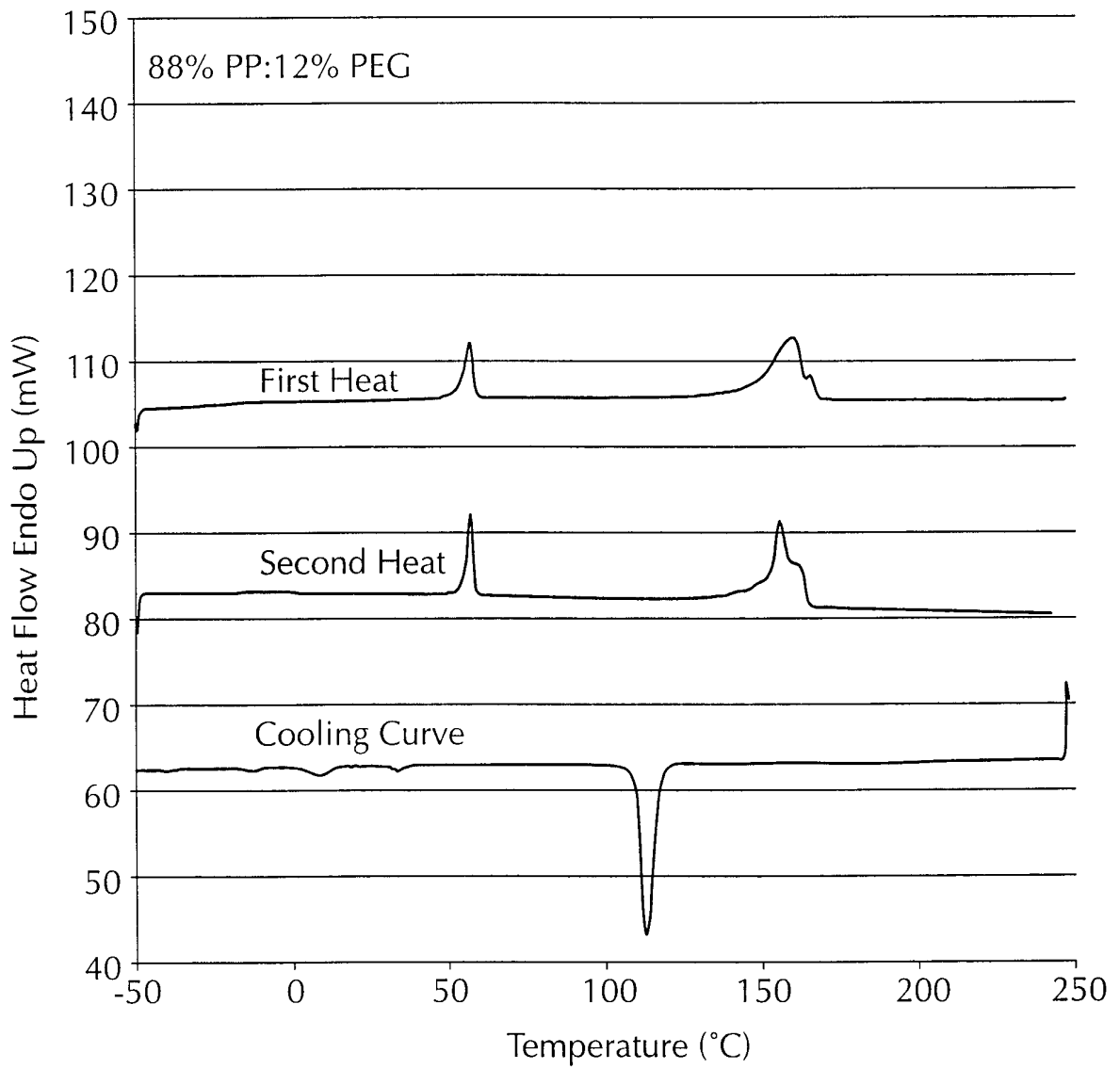

FIG. 12

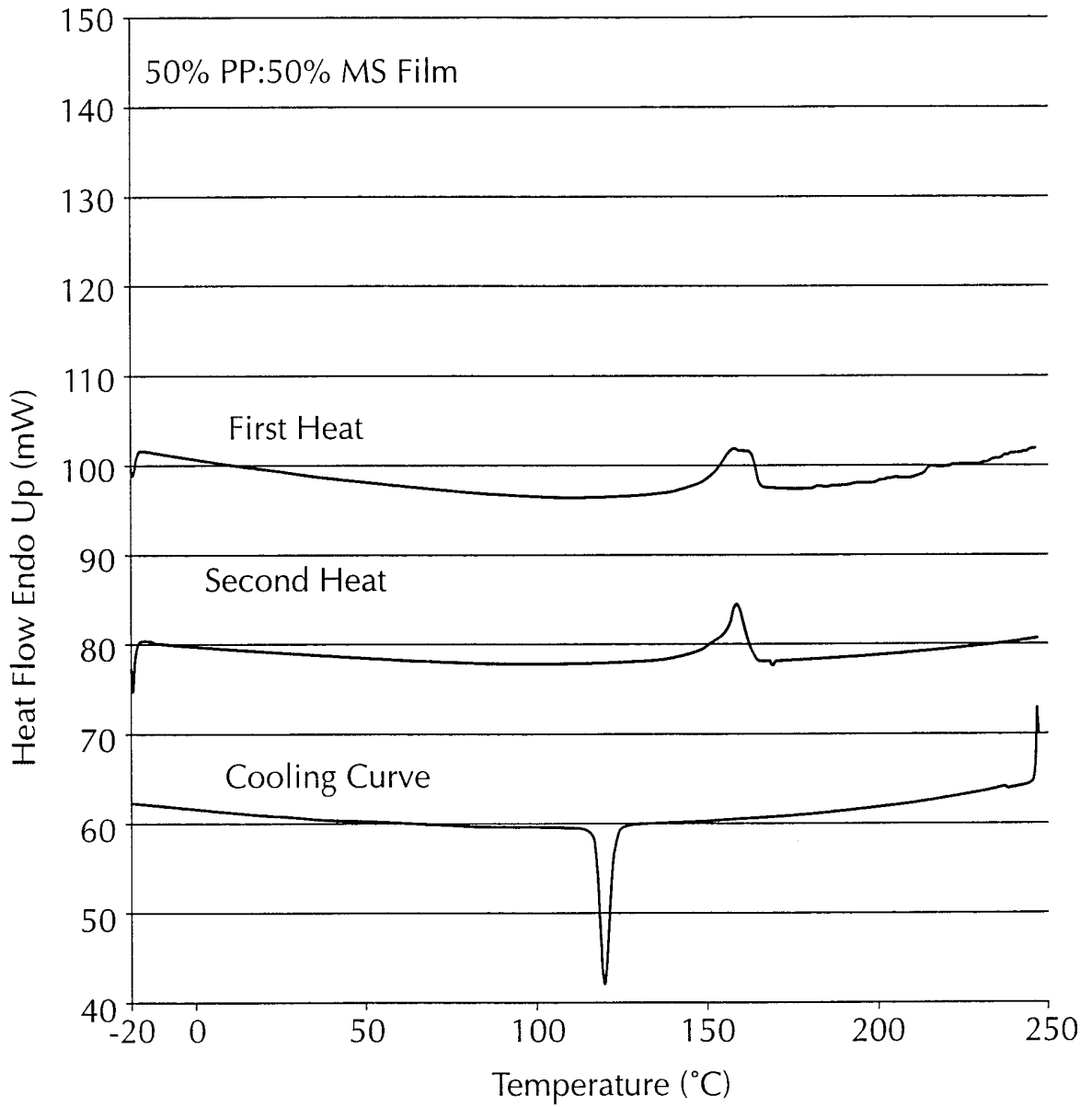

FIG. 13

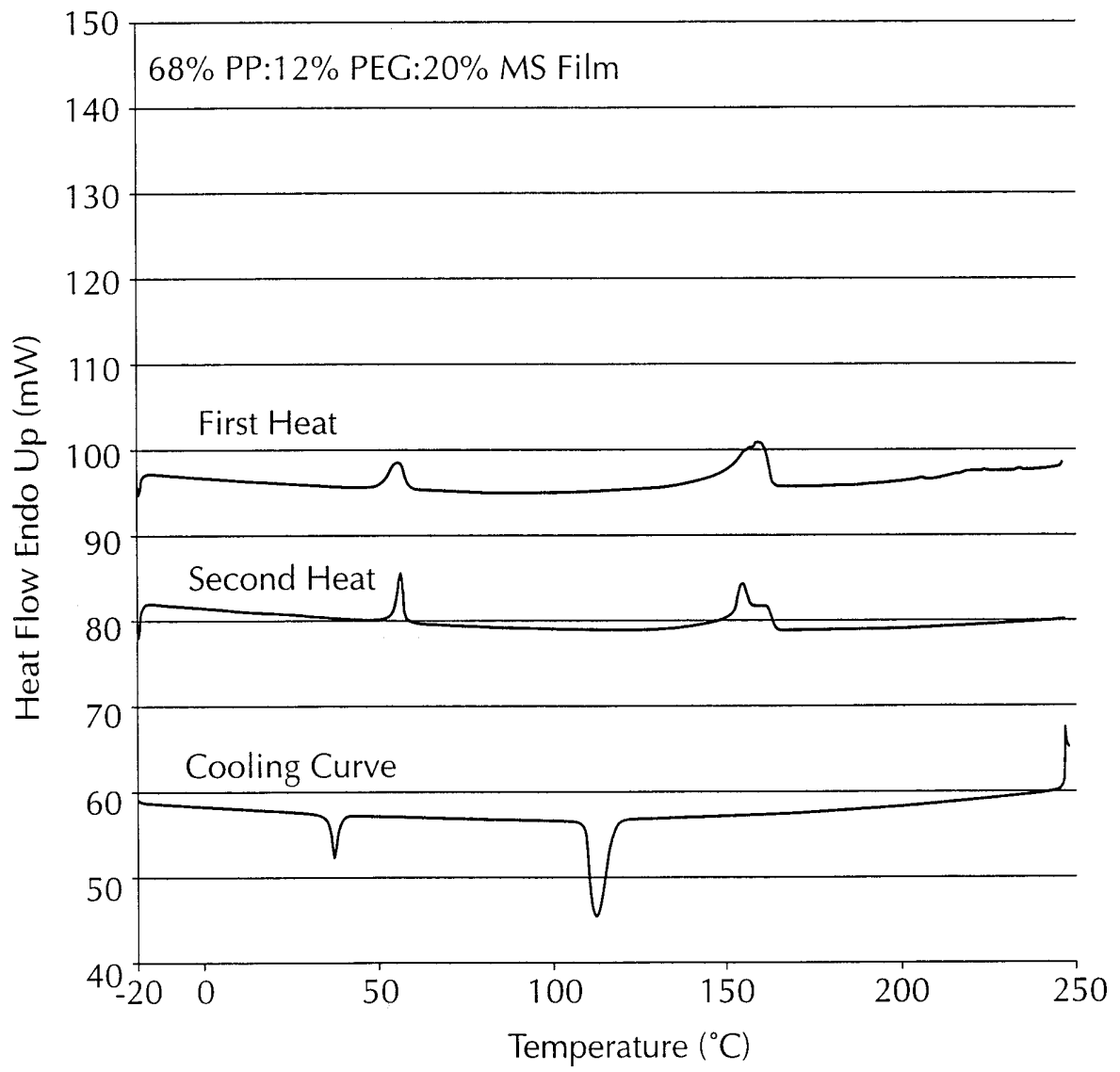

FIG. 14

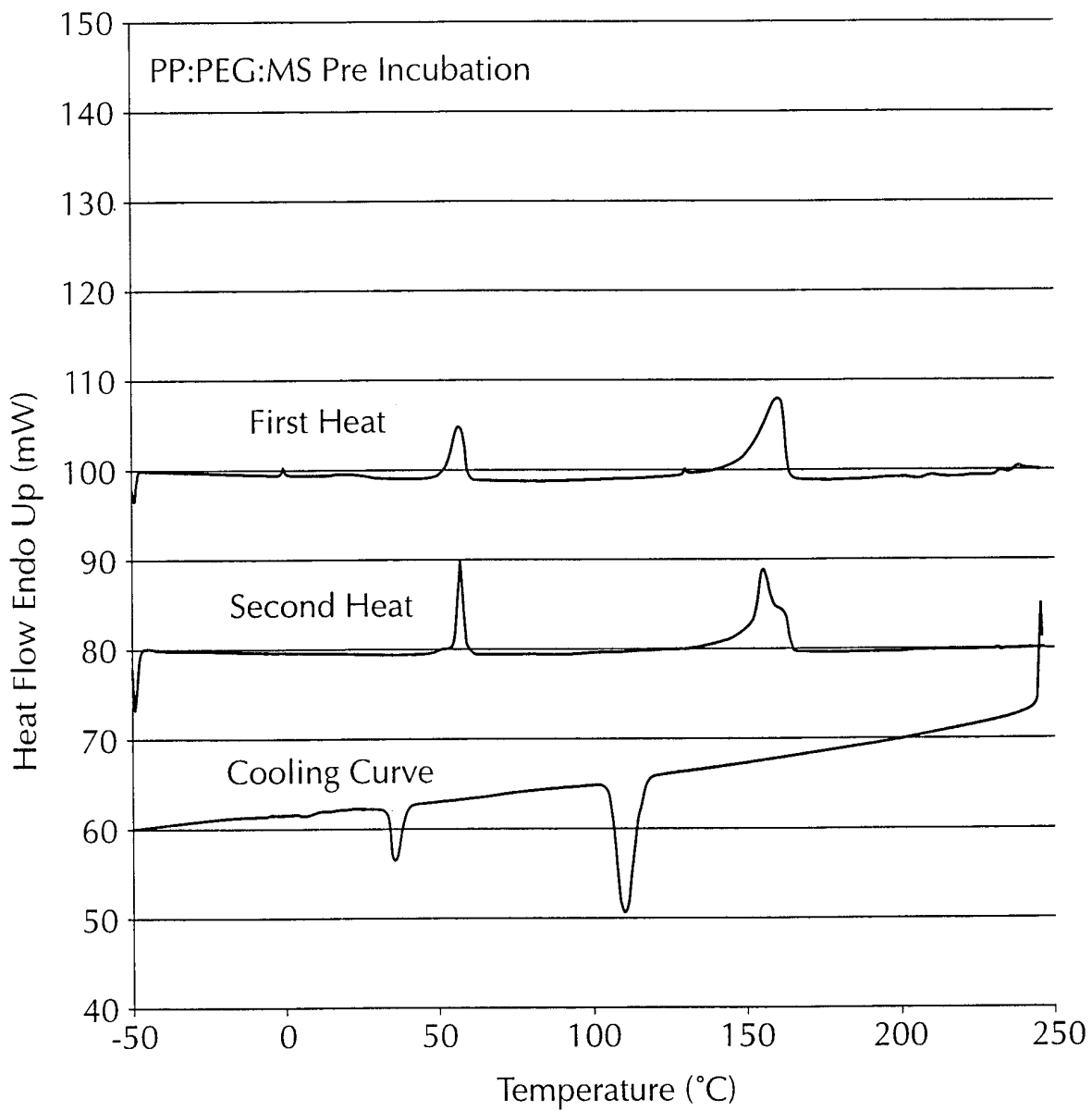

FIG. 15

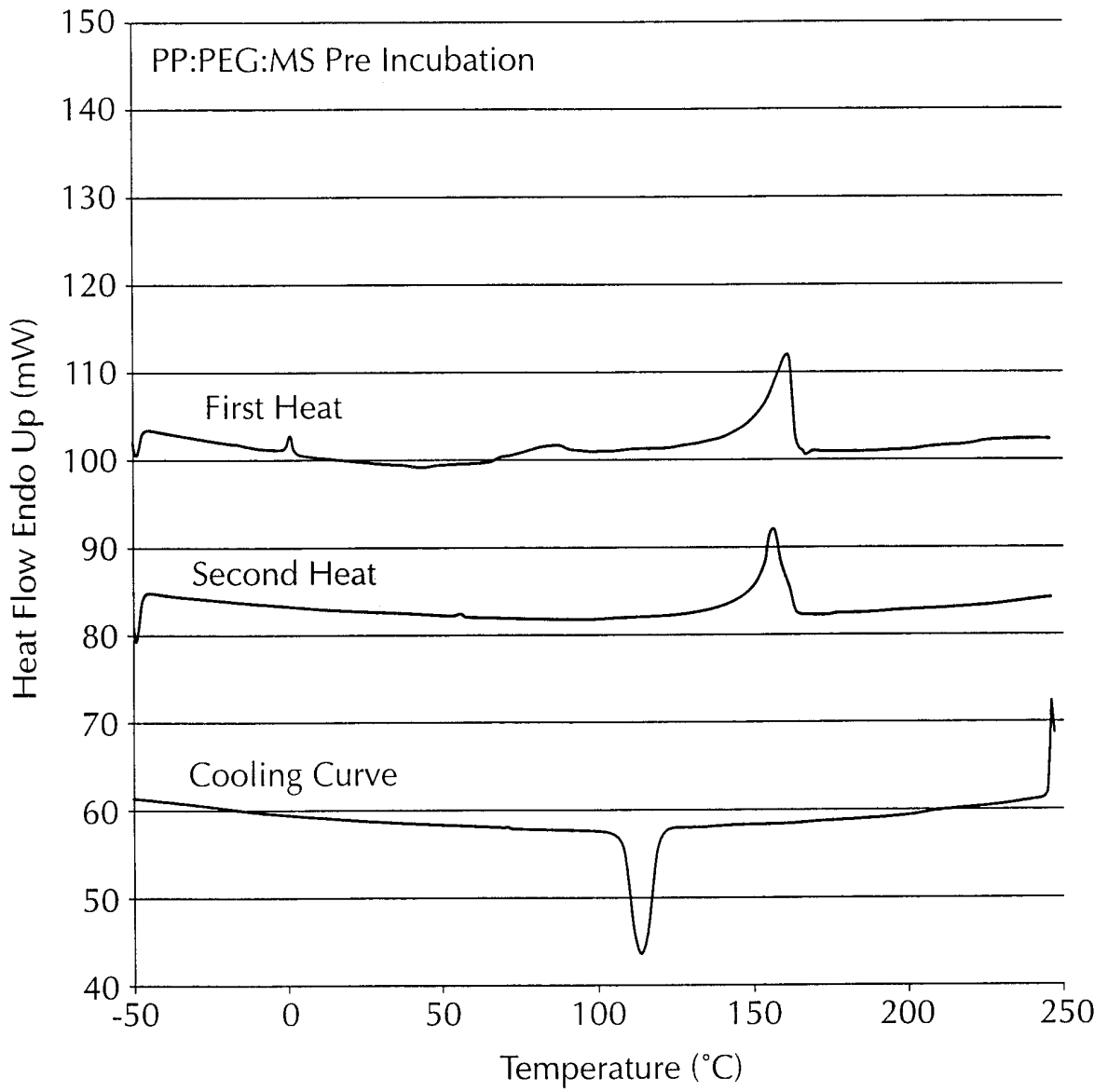

FIG. 16

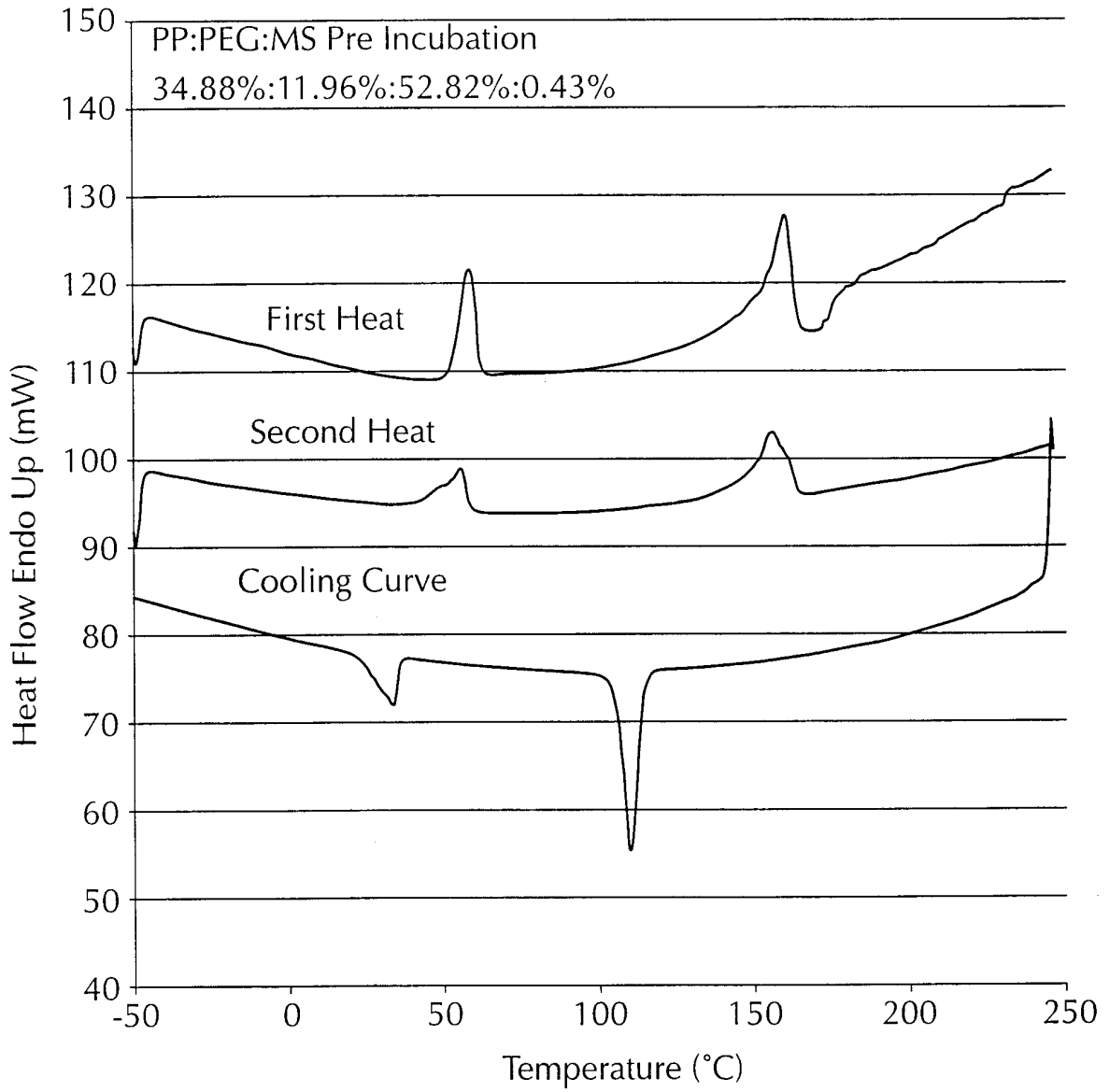

FIG. 17

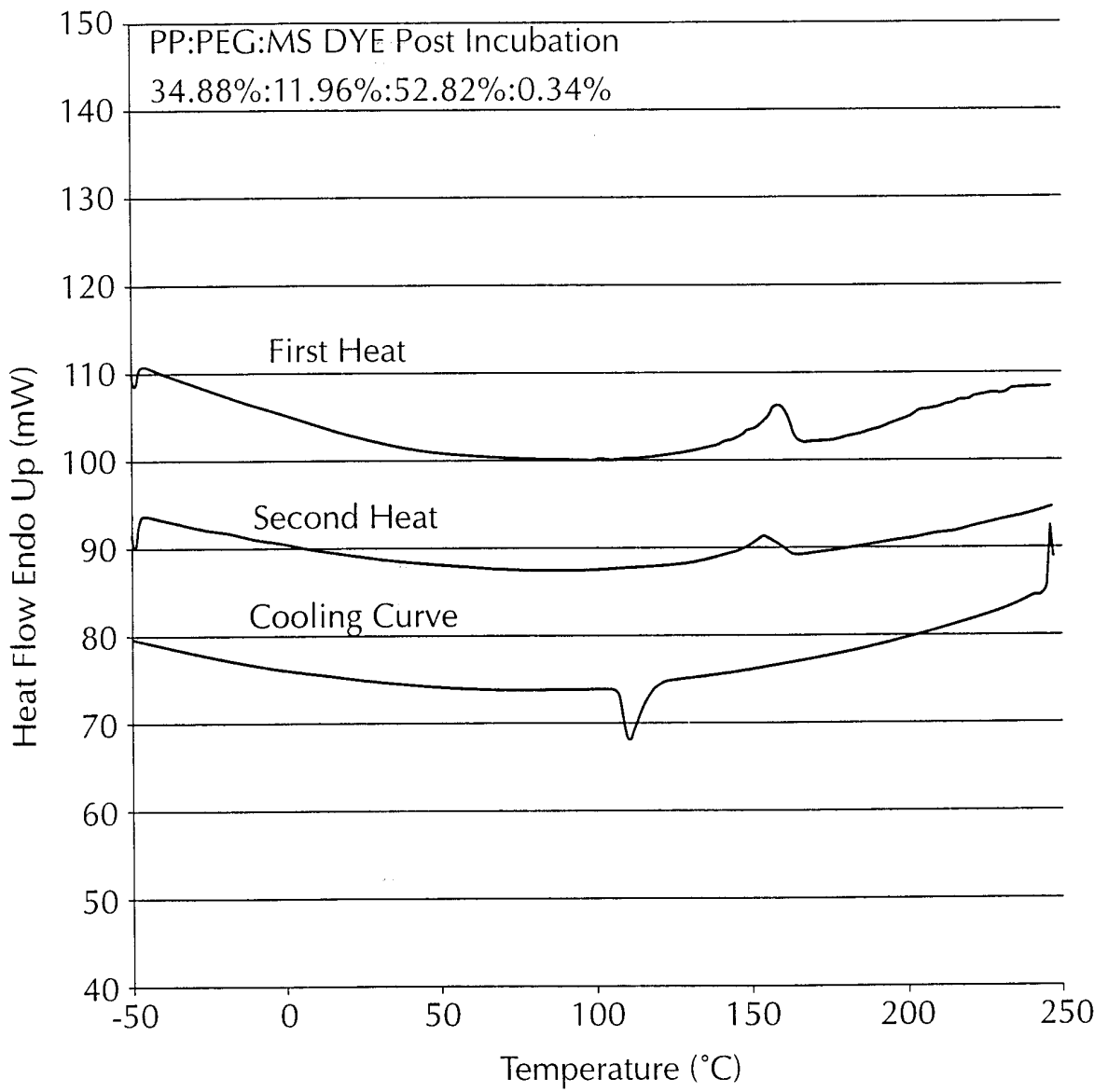

FIG. 18

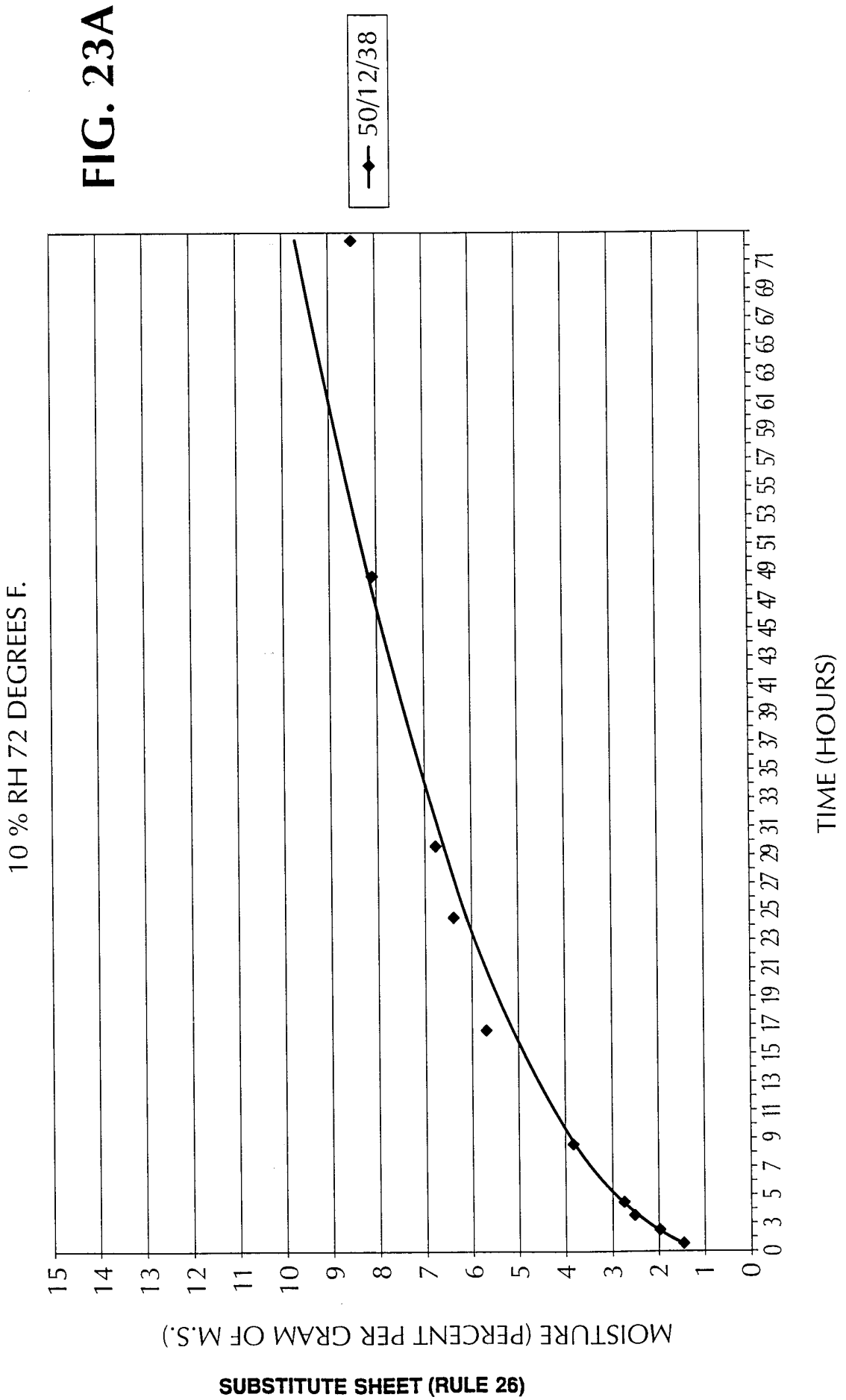
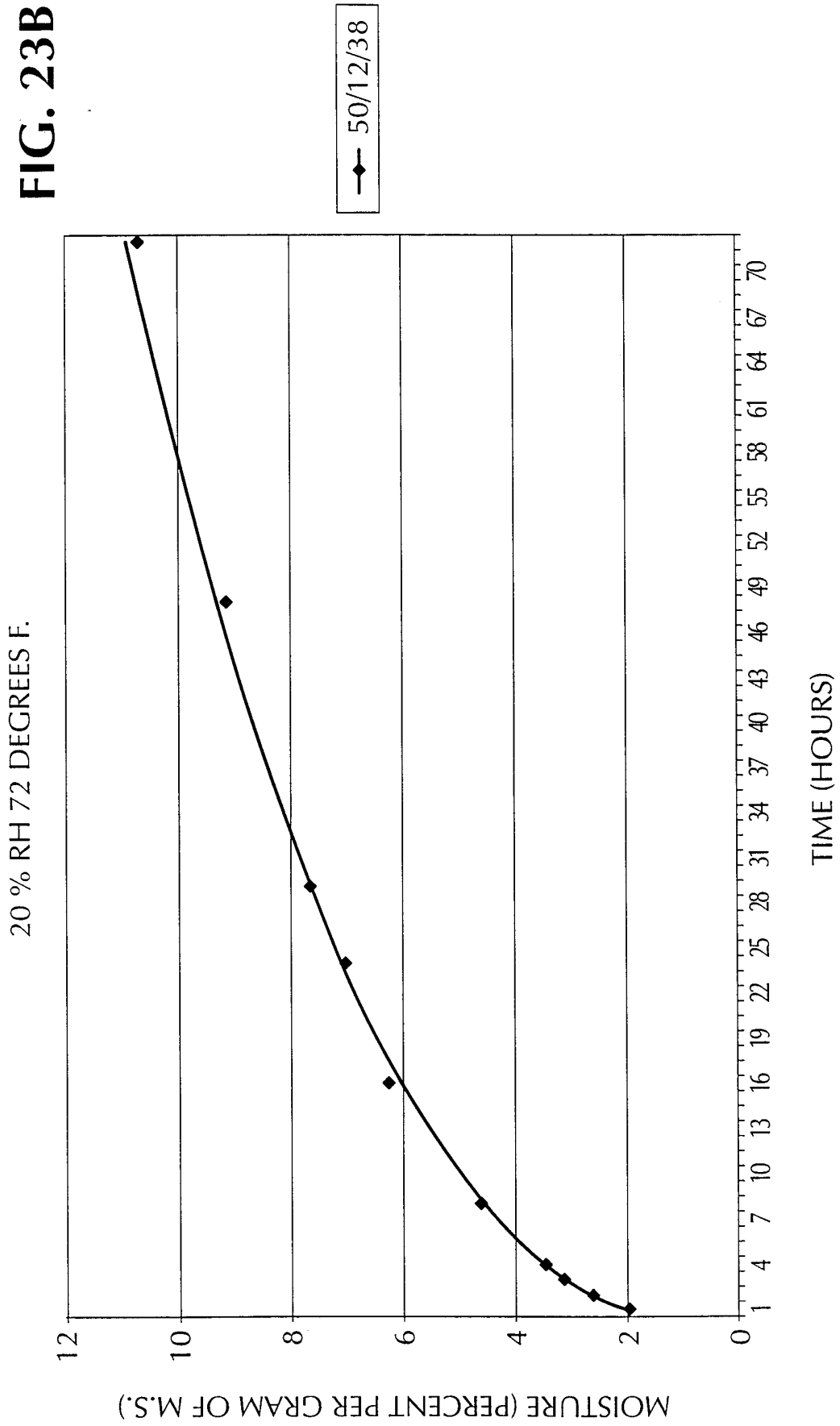

FIG. 23B



INTERNATIONAL SEARCH REPORT

International application No.
PCT/US99/21423

A. CLASSIFICATION OF SUBJECT MATTER

IPC(6) : C08J 9/00
US CL : 524/387; 521/50

According to International Patent Classification (IPC) or to both national classification and IPC

B. FIELDS SEARCHED

Minimum documentation searched (classification system followed by classification symbols)

U.S. : 524/387, 550; 521/50, 99, 122, 905

Documentation searched other than minimum documentation to the extent that such documents are included in the fields searched

Electronic data base consulted during the international search (name of data base and, where practicable, search terms used)

EAST: polyolefin, polycarbonate, polyamide, polyglycol, polyvinyl alcohol, glycerin, silica gel, clay, molecular sieve

C. DOCUMENTS CONSIDERED TO BE RELEVANT

Category*	Citation of document, with indication, where appropriate, of the relevant passages	Relevant to claim No.
Y	US 3,375,208 A (DUDDY) 26 March 1968, see entire document	1-12
A	US 3,931,067 A (GOLDBERG et al.) 6 January 1976, see entire document	1-12
A	US 4,284,671 A (CANCIO et al.) 18 August, 1981, see entire document	1-12

Further documents are listed in the continuation of Box C. See patent family annex.

* Special categories of cited documents:	*T* later document published after the international filing date or priority date and not in conflict with the application but cited to understand the principle or theory underlying the invention
A document defining the general state of the art which is not considered to be of particular relevance	*X* document of particular relevance; the claimed invention cannot be considered novel or cannot be considered to involve an inventive step when the document is taken alone
E earlier document published on or after the international filing date	*Y* document of particular relevance; the claimed invention cannot be considered to involve an inventive step when the document is combined with one or more other such documents, such combination being obvious to a person skilled in the art
L document which may throw doubts on priority claim(s) or which is cited to establish the publication date of another citation or other special reason (as specified)	* & * document member of the same patent family
O document referring to an oral disclosure, use, exhibition or other means	
P document published prior to the international filing date but later than the priority date claimed	

Date of the actual completion of the international search

05 DECEMBER 1999

Date of mailing of the international search report

02 FEB 2000

Name and mailing address of the ISA/US
Commissioner of Patents and Trademarks
Box PCT
Washington, D.C. 20231

Facsimile No. (703) 305-3230

Authorized officer

SUZANNE E. MASON

Telephone No. (703) 308-3829

DAT
DEBORAH THOMAS
PARALEGAL SPECIALIST