

No. 649,631.

Patented May 15, 1900.

V. E. DOREMUS.
BACK PEDALING BRAKE.

(Application filed Mar. 27, 1899.)

(No Model.)

2 Sheets—Sheet 1.

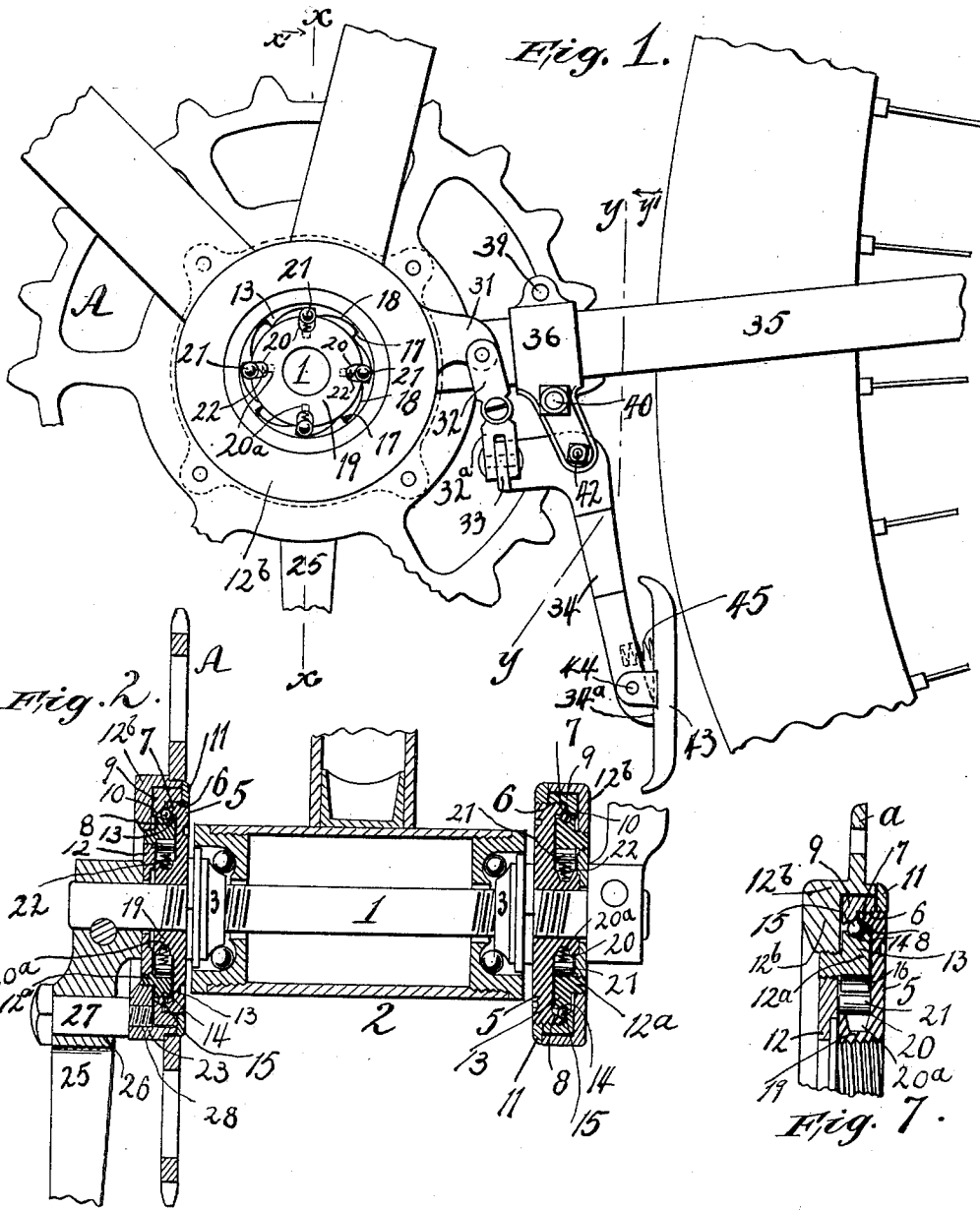

WITNESSES
C. W. Benjamin
M. S. MacLean

INVENTOR
Victor Emanuel Doremus
 BY
Carroll Deement & Co.
 ATTORNEYS

UNITED STATES PATENT OFFICE.

VICTOR EMANUEL DOREMUS, OF NEW YORK, N. Y., ASSIGNOR TO THE
DOREMUS BRAKE AND COASTER COMPANY, OF SAME PLACE.

BACK-PEDALING BRAKE.

SPECIFICATION forming part of Letters Patent No. 649,631, dated May 15, 1900.

Application filed March 27, 1899. Serial No. 710,532. (No model.)

To all whom it may concern:

Be it known that I, VICTOR EMANUEL DOREMUS, a citizen of the United States, and a resident of New York city, county of New York, and State of New York, have invented certain new and useful Improvements in Bicycle Brakes and Coasters, of which the following is a specification, reference being had to the accompanying drawings, forming a part thereof, in which similar letters and figures of reference indicate corresponding parts.

This invention relates to an improvement in bicycle-brakes of the type known as "back-pedaling" brakes, and has for its object the construction of a device of this character adapted to be used as a coaster permitting the driven wheel to run freely while the pedals are held stationary, to apply the brake by the action of back-pedaling, and to be locked so that the coaster and brake mechanism are rigidly connected with the driving-gear, as in the ordinary type of sprocket-and-chain gear.

The invention will be hereinafter fully described, and specifically set forth in the annexed claim.

In the accompanying drawings, forming part of this specification, Figure 1 is a side elevation of the device with the left crank and a portion of the casing removed. Fig. 2 is a cross-sectional view on the line $x x$ of Fig. 1 looking in the direction of the arrow x' . Fig. 3 is a cross-sectional view taken on the line $y y$ of Fig. 1 looking in the direction of the arrow y' . Fig. 4 is a side elevation of the coaster-disk with the crank attached thereto, said crank being partly broken away. Fig. 5 is an inside face view of the clutching device, which forms part of the driving-gear. Fig. 6 is an end elevation of a portion of the crank-hanger, partly broken away in cross-section; and Fig. 7 is a vertical sectional elevation of a part of the clutching and bearing mechanism shown on an enlarged scale.

In the application of my invention I employ a crank-shaft 1, revolvably mounted in the usual manner in the crank-hanger 2. At each end of the shaft, at a point immediately outside of the cone 3 and the crank-hanger bearing, a disk 5 is fixed to the shaft. This disk may be formed integrally with the cone 3 or may be attached to the shaft separately,

as preferred. The periphery of this disk is provided with a screw-thread 6 and with an outwardly-projecting annular ring 7, the inner periphery 8 of which is inclined and adapted to form one part of the ball-race of the coaster. An annular right-angular ring 9 is screwed upon the outer periphery of the disk 5, and the radial portion of this ring is provided with an inclined face 10 at its inner periphery adapted to act in conjunction with the inclined face 8 of the disk 5 and form an adjustable side for the ball-race of the coaster. A lock-nut 11 is threaded upon the outer periphery of the disk 5 to hold the ring 9 securely in position as adjusted.

Loosely mounted upon the shaft outside of the disk 5 is a shell which comprises a disk 12, a ring 12^a, and a right-angular ring 12^b, the ring 12^b being supplied upon its outer periphery with radially-extended lugs a for engagement with the driving-sprocket A, and the inner ring 12^a having threads upon its inner and outer peripheries for connecting the disk 12 with the ring 12^b. Forming an integral part of the ring 12^a is an enlarged ring 13, which is provided upon its outer periphery with a channel 14 for engagement with a series of balls 15, which are held between said ring 13 and the faces of the disk 5 and adjusting-ring 9, the whole forming a single ball-bearing in line with the strain of the chain and sprocket. The inner periphery of the ring 13 is provided with a series of pockets 16, having one radial shoulder 17 and one inclined shoulder 18.

A collar 19 is fixed upon each end of the shaft between the disk 5 and the shell. This collar may be brazed or otherwise fastened to the shaft independent of the disk 5 or may be formed integrally with said disk, as preferred and shown in the drawings. The collar 19 is provided with a series of radial recesses 20. Within these recesses are carried a series of pins or rollers 21, and each of these pins or rollers is normally forced outward radially by means of one of the springs 22, which engage recesses 20^a. When so forced outwardly, the pins or rollers normally lie partly in the pockets of the sprocket-ring and partly within the recesses of the collar, thereby locking the two together effectually

when the shaft is revolved in one direction. When the shaft is rotated in the opposite direction, however, the pins or rollers are carried to and up the inclined shoulder of the ring-pockets, and the ring is thereby unlocked, the springs holding the pins at all times in contact with the inner periphery of the ring.

When it is desired that the device be used with or without employing the coasting device, the shell carrying the sprocket is provided with an extension, preferably an annular outwardly-projecting ring 23, as best shown in Fig. 4; but, if desired, this projection may be reduced in size, as at dotted lines *b*, Fig. 4 of the drawings. The crank 25 is attached to the shaft in any approved manner and is provided with a hole 26, in which the screw 27 is adapted to be passed, this screw threading into a suitable hole 28 in the ring 23, thereby locking effectually the sprocket to the crank. When it is desired to use the coasting device, it is simply necessary to remove the screw from the crank, and when this is done a spring-cap 29 of any approved design may be substituted therefor, the cap being designed to exclude dust from the hole. A short screw-plug 30 may be threaded into the hole 28, adapted to fill the said hole and keep the dirt from clogging therein, said plug being flush with the outer surface of the ring 23, so that it will not interfere with the rotation of the sprocket past the boss of the crank. If preferred, the ring may be dispensed with and the boss be of sufficient size to hold the screw 27 securely to the sprocket.

The construction of the brake-locking mechanism is the same as that of the coaster, except that it is reversed and locks only during the rearward rotation of the shaft, while the coaster locks only during the forward rotation of the shaft. The outer shell of the brake-lock is provided with the spur 31, projecting rearwardly therefrom. To this spur is pivoted the link 32, which is in turn pivoted to the link 32^a, which is pivotally connected to the angular portion 33 of the brake-arm 34. The brake-arm 34 is pivoted to a downwardly-projecting yoke or hanger 36, which comprises two clamping-sections 37 and 38, which engage one of the chain-stays of the bicycle, the sections being held together by means of a screw

39 and a bolt 40, the said bolt having an extension 41 bearing upon the opposite chain-stay to prevent turning of the hanger upon its chain-stay. To prevent binding of the brake-arm 34 within the hanger, the lower ends of said hanger are kept apart by means of a collar 42^a, formed around the pin 42, which acts as a pivot for the said brake-arm. A brake-shoe 43 is connected to the lower end of the brake-arm, preferably by means of the pivot 44, but may be formed integrally therewith, if preferred. To limit the movement of said brake-shoe and prevent normal contact with the wheel-tire, a shoulder 34^a is formed upon the lower end of the brake-arm 34, and the shoe is maintained in engagement with the said shoulder by means of a spring 45.

In the preferred construction the ring 13 is supplied with a number of pockets 17 equaling double the number of ball-recesses contained in the collar 19. This relative arrangement is for the purpose of reducing lost motion when reversing the movement of the shaft.

Having thus described my invention, what I claim as new, and desire to secure by Letters Patent, is—

In a back-pedaling brake for bicycles, or similar vehicles, the combination of a shell having an arm extended therefrom and being loosely mounted upon the crank-shaft, and means for locking the shell to the shaft only during backward rotation of the said shaft, with a brake comprising a split collar and integrally-formed hangers clamped to one of the chain-stays of the bicycle-frame, a clamping-bolt therefor which has an extension bearing on the opposite chain-stay, a downwardly-extended arm pivotally attached to the said hanger and connected to a brake-shoe, a forwardly and upwardly extended arm and a link pivoted to the arm of the said shell, substantially as shown and described.

In testimony that I claim the foregoing as my invention I have signed my name, in the presence of two witnesses, this 20th day of March, 1899.

VICTOR EMANUEL DOREMUS.

Witnesses:

R. L. CLAUSON,
M. G. MACLEAN.