

CORRECTED VERSION

(19) World Intellectual Property Organization
International Bureau



(10) International Publication Number
WO 2014/000070 A9

(43) International Publication Date
3 January 2014 (03.01.2014)

- (51) International Patent Classification: *H02K 1/14* (2006.01) *H02K 15/02* (2006.01)
- (21) International Application Number: PCT/BR2013/000215
- (22) International Filing Date: 18 June 2013 (18.06.2013)
- (25) Filing Language: English
- (26) Publication Language: English
- (30) Priority Data: BR1020120162881 29 June 2012 (29.06.2012) BR
- (71) Applicant: **WHIRLPOOL S.A.** [BR/BR]; Avenida das Nações Unidas, nº 12.995, 32° andar, Brooklin Novo, São Paulo, SP, 04578-000 (BR).
- (72) Inventors: **FELDMANN, Alberto Bruno**; Rua Cabral, 392, Joinville, SC, 89221-570 (BR). **ESPÍNDOLA, Alejandro Amauri de**; Rua Henrique Miers, 203, Apto. 223, Joinville, SC, 89218-600 (BR). **LINK, Rodrigo**; Rua Alvarenga Peixoto, 148, Apto. 401, Joinville, SC, 89204-430 (BR).
- (74) Agent: **RODRIGUES, Carina S.**; Daniel Advogados, Rua Joaquim Floriano, 413, 13° andar, Itaim Bibi, São Paulo, SP, 04534-011 (BR).
- (81) Designated States (*unless otherwise indicated, for every kind of national protection available*): AE, AG, AL, AM, AO, AT, AU, AZ, BA, BB, BG, BH, BN, BR, BW, BY, BZ, CA, CH, CL, CN, CO, CR, CU, CZ, DE, DK, DM, DO, DZ, EC, EE, EG, ES, FI, GB, GD, GE, GH, GM, GT, HN, HR, HU, ID, IL, IN, IS, JP, KE, KG, KN, KP, KR, KZ, LA, LC, LK, LR, LS, LT, LU, LY, MA, MD, ME, MG, MK, MN, MW, MX, MY, MZ, NA, NG, NI, NO, NZ, OM, PA, PE, PG, PH, PL, PT, QA, RO, RS, RU, RW, SC, SD, SE, SG, SK, SL, SM, ST, SV, SY, TH, TJ, TM, TN, TR, TT, TZ, UA, UG, US, UZ, VC, VN, ZA, ZM, ZW.
- (84) Designated States (*unless otherwise indicated, for every kind of regional protection available*): ARIPO (BW, GH, GM, KE, LR, LS, MW, MZ, NA, RW, SD, SL, SZ, TZ, UG, ZM, ZW), Eurasian (AM, AZ, BY, KG, KZ, RU, TJ, TM), European (AL, AT, BE, BG, CH, CY, CZ, DE, DK, EE, ES, FI, FR, GB, GR, HR, HU, IE, IS, IT, LT, LU, LV, MC, MK, MT, NL, NO, PL, PT, RO, RS, SE, SI, SK, SM, TR), OAPI (BF, BJ, CF, CG, CI, CM, GA, GN, GQ, GW, KM, ML, MR, NE, SN, TD, TG).

[Continued on next page]

(54) Title: LAMINAR SEGMENT FOR ELECTRIC MOTOR SEGMENTED STATOR

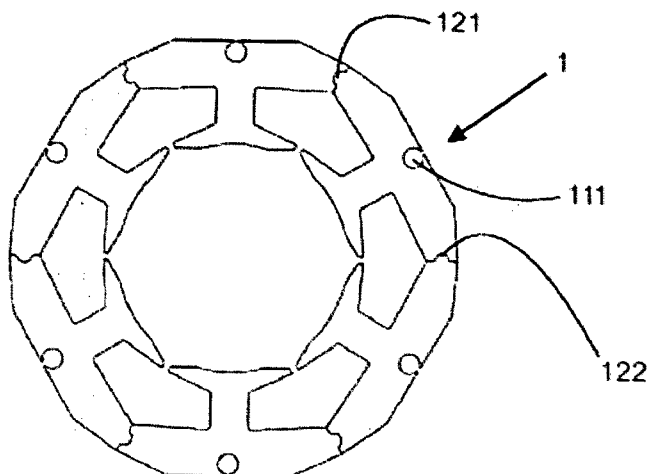

FIG. 2

(57) Abstract: The present invention refers to an electric motor with segmented stator and a fluid compressor provided with an electric motor with segmented stator. Segmented stator (E) of the electric motor is composed of segments (4), wherein each segment (4) is constituted by a plurality of laminar segments (1) comprised of at least an external segment (11) and at least a tooth (13).

WO 2014/000070 A9

Published:

— *with international search report (Art. 21(3))*

(48) Date of publication of this corrected version:

24 December 2014

(88) Date of publication of the international search report:
1 May 2014

(15) Information about Correction:
see Notice of 24 December 2014

"LAMINAR SEGMENT FOR ELECTRIC MOTOR SEGMENTED STATOR"

Field of the Invention

The present invention refers to the technology of electric motor and similar equipments.

The present invention generally relates to a laminar segment for electric motor segmented stator and, more particularly, to the geometry and/or format of said laminar segment for electric motor segmented stator.

Background of the Invention

It is already known by those skilled in the art electric motors which comprise machines capable of converting electric energy to mechanic energy.

Generally speaking, and according to specialized academic publications, electric motors comprise fixed inductive cores and mobile inductive cores, and have their main functional principle based on electromagnetic induction principles, where magnetic fields generated by the fixed inductive cores are capable of generating movement in the mobile inductive cores. In this sense, it is also known by those skilled in the art that the fixed inductive cores are disclosed in the stator while the mobile inductive cores are arranged in the rotor.

From the constructive point of view, an electric motor stator is essentially composed of a metal frame and a plurality of coils (electric conductors disposed in a manner surrounding a shaft), wherein said coils are disposed in alignment with the metal frame.

In this sense, and as known by those skilled in the art, a stator package of an electric motor can be obtained from a metal monoblock from a plurality of metal blades, or also from a plurality of metal blade segments. This latter type of stator is named segmented stator.

The main advantages of a segmented stator over a monoblock stator ou a laminar stator are particularly perceivable when analyzed from an industrial point of view. This mainly occurs due to raw material savings since laminar segments can be obtained from an essentially thin metal blade in stamping processes because blade formats allow for spaces between the segments to be reduced. Furthermore, with regard to the cases where a rotor core is not formed of blades, according to BR Patent Application PI0905651-3, material savings are increased. The second advantage provided by the use of laminar segments refers to improvement in winding process since access to the groove remains totally free, thereby enhancing the accuracy to guide a yarn around each coil winding, thereby making it possible to carry out the concentrate yarn winding process and, consequently, to add a higher number of turns and/or higher volume of coil material to one same groove area.

Examples of laminar segments as well as examples of segmented stators are disclosed in EP 1364442, JP 2020141942, US 7414347, US 7471025, US 7821175, and CN

201008100.

EP 1364442 and US 7414347 describe in a simplified form stator segments formed of multiple laminar segments. Each of said laminar segments has a contour analogous to a T-shape wherein a substantially horizontal portion further comprises a side recess and a side protrusion, both oppositely disposed to form self-coupling "male-female" members and specially intended to join the stator segments.

With regard to JP 2010141942 and US 7471025 describe examples of geometries of laminar segments. In addition, such documents also teach blade matrices, from which said laminar segments are removed (using stamping processes).

US 7821175 and CN 201008100 in turn disclose segmented stators formed by physical association of stator segments. In both documents, it is also common to see that physical association of stator segments provides for the use of external structures, such as, for example, ring-shaped structures.

Although the above-mentioned documents only illustrate examples of embodiments pertaining to the state of the art, it can be clearly noted that most of the currently existing segmented stators include fundamental aspects disclosed in such examples. From this observation the main drawbacks referring to these examples and, consequently, presented in most of currently existing segmented stators are easily verified.

The first drawback refers to a constructive point of view. As disclosed in JP 2010141942 and US 7471025, it is observed that the current blade matrices in function of the geometry of the laminar segments generate high amount of metal scrap. This is due to the fact that said geometry of the laminar segments aims at generating higher functional efficiency to the stator and not a smaller amount of scrap.

The second drawback refers to stator assembly and/or arrangement. US 7821175 and CN 201008100 teach that the stator assembly requires the use of external structures which add dimensions to said stator.

The present invention has been developed based on this scenario.

Objects of the invention

Hence, an object of the present invention is to provide a laminar segment for electric motor segmented stator having geometry capable of reducing the amount of scrap (raw material optimization) without impairing electric efficiency of said motor. Another object of the present invention is to provide a laminar segment for electric motor segmented stator that has the ability to use aluminum thread in the composition of its coil.

Summary of the Invention

These and other objects of the present invention are achieved by means of a laminar segment for electric motor segmented stator, which comprises at least an external segment and at least a perpendicular segment called tooth, in addition to containing two side

ends projected from each of the side ends of the external segment (that after joining said segments in the assembly is named crown), and two side ends projected from each of said lower ends of the tooth. Said side ends have right faces substantially parallel therebetween and left faces also substantially parallel therebetween. Preferably, one of said side ends further comprises a coupling projection while the other side end comprises a coupling recess.

In accordance with the principles and objects of the present invention, the right faces have an angular inclination complementary to the angular inclination of the left faces. It should be pointed out that, in accordance with the present invention, said electric motor having a segmented stator comprises electric coils made of aluminum.

Brief Description of Drawings

The present invention will be described in detail based on the figures listed below, wherein:

Fig. 1 illustrates a second laminar segment for the electric motor segmented stator in accordance with the present invention;

Fig. 2 illustrates laminar segments for the electric motor segmented stator in the blade matrix disposed at the blade matrix in accordance with the present invention; and

Figure 3 illustrates laminar segments for the segmented stator in the stator package itself.

Detailed Description of the Invention

As previously mentioned, one of the main objects of the present invention is to provide laminar segments (that in conjunction form segments for electric motor segmented stators) which can be obtained/made of an optimized amount of raw material (metal blades and/or sheets).

In this sense, and in accordance with the present invention, a laminar segment 1 that is depicted in Figure 1 in an amplified form is disclosed.

Said laminar segment 1 that has geometry essentially analogous to letter T is essentially constituted by an external segment 11 and a tooth 13, wherein said external segment 11 corresponds to the horizontal portion of the T-shaped geometry; and said tooth 13 corresponds to the vertical portion of said T-shaped geometry. Attention should be drawn to the fact that laminar segments having T-shaped geometry are widely known by those skilled in the art.

Nevertheless, and unlike the laminar segments pertaining to the current state of the art, the presently disclosed laminar segment 1 is shown to have two end sides 12 projected from each of the side ends of the external segment 11 and two side ends 14 projected from each of said lower side ends of tooth 13.

As can be seen from Fig. 1, it is essentially required that said side end 12 and said side end 14 of opposite sides of one same laminar segment 1 have substantially parallel

faces therebetween.

Additionally, as shown in Figure 2, and according to a second preferred embodiment of the laminar segment 1, an optimized geometry aiming at reducing raw material is obtained when said side ends 12 and side ends 14 have right faces (FD) substantially parallel therebetween, and when said side ends 12 and said side ends 14 comprise right faces (FE) substantially parallel therebetween.

It is then observed that, in accordance with the preferred embodiment of the laminar segment 1, the right faces FD have an angular inclination complementary to the angular inclination of the left faces FE, wherein the reverse is evidently true.

Such geometry permit to define in one same blade matrix 2 multiple laminar segments 1, which segments have their side ends 12 and 14 "resting" against one another. It is then verified that said laminar segments 1 (of one same blade matrix 2) can be "separated" from one another through linear cuts 21 (virtual lines). Generation of raw material scrap R in accordance with the laminar segment 1 is significantly smaller than the generation of scrap relative to laminar segments pertaining to the state of the art.

Preferably, in accordance with a now detailed preferred embodiment, the multiple laminar segments 1 are defined in one same blade matrix 2, and "separated" from each other by means of conventional stamping processes, which are usually carried out in presses.

Further, as illustrated in Fig. 1, it is observed that preferably each lamina segment 1 additionally comprises a circular face 15 that is defined at the lower end of its tooth 13. However, and in a further preferred form, it is further verified that the external segment 11 of the laminar segment 1 has also a centrally disposed through-hole 111.

Moreover, in an optional form, it should be cited that one of said side ends 12 (according to the attached figures, left side end 12) also comprises a coupling projection 121 whereas the other side end 12 (according to the attached figures, left right side end 12) also comprises a coupling recess 122. Coupling projections 121 and coupling recesses 122 assist segments 4 to be joined, as depicted in Figure 3.

Each segment 4 is composed of a plurality of laminar segments 1, all of them vertically aligned (or disposed) with one another.

Still in accordance with Fig. 3, it can be noted that said segments 4 in accordance with the present invention can be joined to one another to thereby define the structural portion of stator E.

One of the advantages presented by using segmented stators refers to the possibility of winding metal conductors 5 (electric coil) around multiple teeth 13 of the (duly joined) multiple laminar segments 1 before the final mounting of the stator E itself.

It should be pointed out that in accordance with the present invention segments 4 of the presently disclosed stator E preferably use metal conductors 5 made of aluminum.

Having described the preferred embodiment of the present invention, it should be understood that the scope thereof contemplates other possible variations, which are only limited by the contents of the appended claims, including possible equivalent means.

CLAIMS

1. Laminar segment for electric motor segmented stator, comprising at least an external segment (11) and at least a tooth (13), said laminar segment being characterized in that it especially comprises:

two side ends (12) projected from each of said side ends of the external segment (11);

two side ends (14) projected from each of said lower side ends of perpendicular segment (13);

the side ends (12) and side ends (14) comprise right faces (FD) substantially parallel therebetween; and

the side ends (12) and side ends (14) comprise left faces (FE) substantially parallel therebetween.

2. Laminar segment, in accordance with claim 1, characterized in that the right faces (FD) comprise an angular inclination complementary to the angular inclination of the left faces (FE).

3. Laminar segment, in accordance with claim 1, characterized in that each laminar segment (1) comprises a circular face (5) disposed between the side ends (14).

4. Laminar segment, in accordance with claim 1, characterized in that said external segment (11) further comprises a through-hole (111).

5. Laminar segment, in accordance with claim 1, characterized in that one of said side ends (12) further comprises a coupling projection (121).

6. Laminar segment, in accordance with claim 1, characterized in that one of said side ends (12) further comprises a coupling recess (122).

7. Laminar segment, in accordance with claim 1, characterized in that it comprises electric coils (5) made of aluminum.

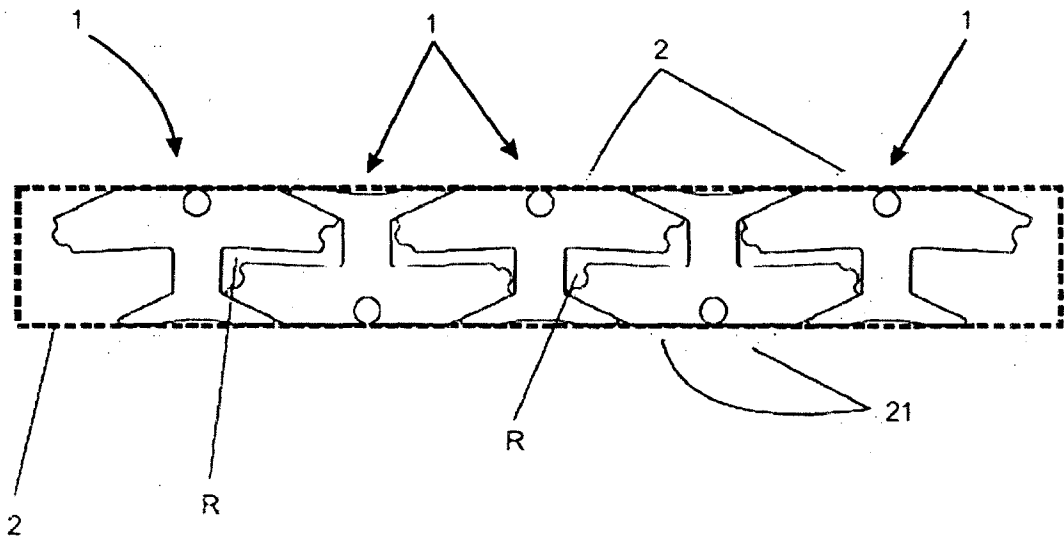
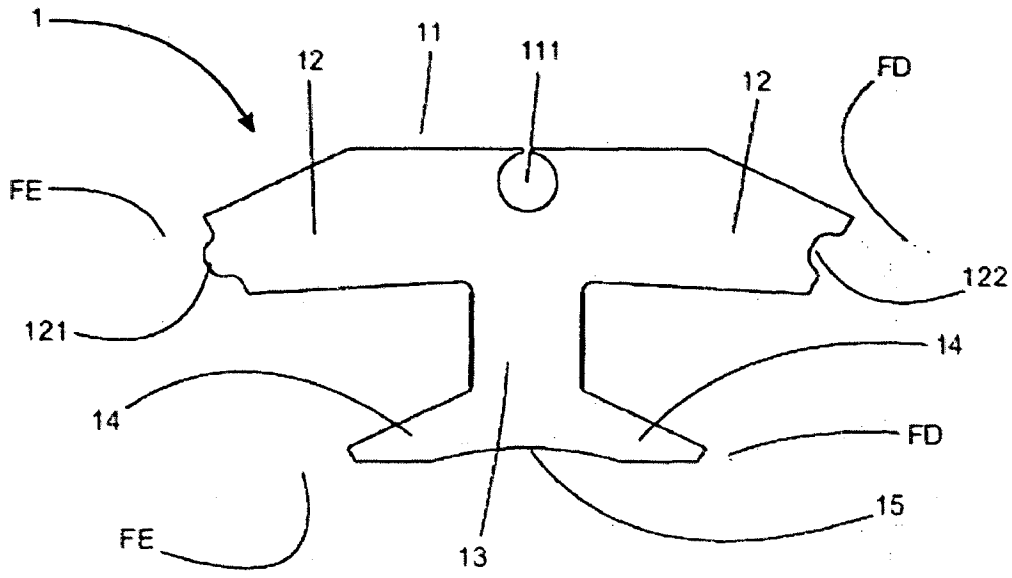

FIG. 1

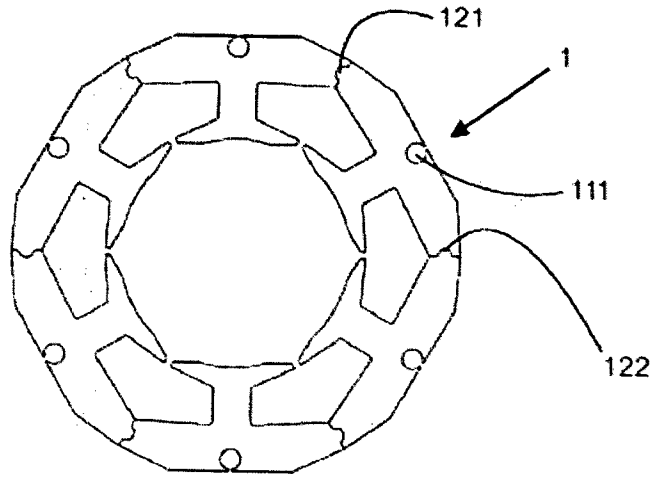

FIG. 2

INTERNATIONAL SEARCH REPORT

International application No
PCT/BR2013/000215

A. CLASSIFICATION OF SUBJECT MATTER
 INV. H02K1/14 H02K15/02
 ADD.
 According to International Patent Classification (IPC) or to both national classification and IPC

B. FIELDS SEARCHED
 Minimum documentation searched (classification system followed by classification symbols)
 H02K
 Documentation searched other than minimum documentation to the extent that such documents are included in the fields searched

Electronic data base consulted during the international search (name of data base and, where practicable, search terms used)
 EPO-Internal

| Category* | Citation of document, with indication, where appropriate, of the relevant passages | Relevant to claim No. |
|-----------|---|-----------------------|
| X | JP 2009 247169 A (FUJITSU GENERAL LTD) 22 October 2009 (2009-10-22) abstract; figures 1-6 ----- | 1-7 |
| X | JP 2009 254086 A (MITSUBISHI ELECTRIC CORP) 29 October 2009 (2009-10-29) abstract; figures 12,23,24,27 ----- | 1 |
| X | US 2004/201303 A1 (ZHANG DONGNING [JP] ET AL) 14 October 2004 (2004-10-14) figures 3,5,10 ----- | 1 |
| A | JP 2000 069693 A (MATSUSHITA ELECTRIC IND CO LTD) 3 March 2000 (2000-03-03) abstract; figures 1-3 ----- | 1-7 |
| A | DE 10 2008 057390 A1 (BOSCH GMBH ROBERT [DE]) 20 May 2010 (2010-05-20) figures 2-4,6 ----- | 1-7 |

Further documents are listed in the continuation of Box C.

See patent family annex.

* Special categories of cited documents :

| | |
|---|---|
| <p>"A" document defining the general state of the art which is not considered to be of particular relevance</p> <p>"E" earlier application or patent but published on or after the international filing date</p> <p>"L" document which may throw doubts on priority claim(s) or which is cited to establish the publication date of another citation or other special reason (as specified)</p> <p>"O" document referring to an oral disclosure, use, exhibition or other means</p> <p>"P" document published prior to the international filing date but later than the priority date claimed</p> | <p>"T" later document published after the international filing date or priority date and not in conflict with the application but cited to understand the principle or theory underlying the invention</p> <p>"X" document of particular relevance; the claimed invention cannot be considered novel or cannot be considered to involve an inventive step when the document is taken alone</p> <p>"Y" document of particular relevance; the claimed invention cannot be considered to involve an inventive step when the document is combined with one or more other such documents, such combination being obvious to a person skilled in the art</p> <p>"&" document member of the same patent family</p> |
|---|---|

| | |
|--|--|
| Date of the actual completion of the international search 11 March 2014 | Date of mailing of the international search report 19/03/2014 |
|--|--|

| | |
|--|---|
| Name and mailing address of the ISA/ European Patent Office, P.B. 5818 Patentlaan 2 NL - 2280 HV Rijswijk Tel. (+31-70) 340-2040, Fax: (+31-70) 340-3016 | Authorized officer Kanelis, Konstantin |
|--|---|

INTERNATIONAL SEARCH REPORT

Information on patent family members

International application No

PCT/BR2013/000215

| Patent document cited in search report | Publication date | Patent family member(s) | Publication date |
|--|------------------|--|--|
| JP 2009247169 A | 22-10-2009 | JP 4983695 B2 JP 2009247169 A | 25-07-2012 22-10-2009 |
| ----- | | | |
| JP 2009254086 A | 29-10-2009 | JP 4884418 B2 JP 2009254086 A | 29-02-2012 29-10-2009 |
| ----- | | | |
| US 2004201303 A1 | 14-10-2004 | CN 1521916 A JP 2004260985 A US 2004201303 A1 | 18-08-2004 16-09-2004 14-10-2004 |
| ----- | | | |
| JP 2000069693 A | 03-03-2000 | NONE | |
| ----- | | | |
| DE 102008057390 A1 | 20-05-2010 | CN 102224656 A DE 102008057390 A1 EP 2356734 A1 JP 2012509048 A WO 2010054824 A1 | 19-10-2011 20-05-2010 17-08-2011 12-04-2012 20-05-2010 |
| ----- | | | |