

No. 877,699.

PATENTED JAN. 28, 1908.

G. P. BLACKISTON.
VISE.

APPLICATION FILED JULY 23, 1907.

2 SHEETS—SHEET 1.

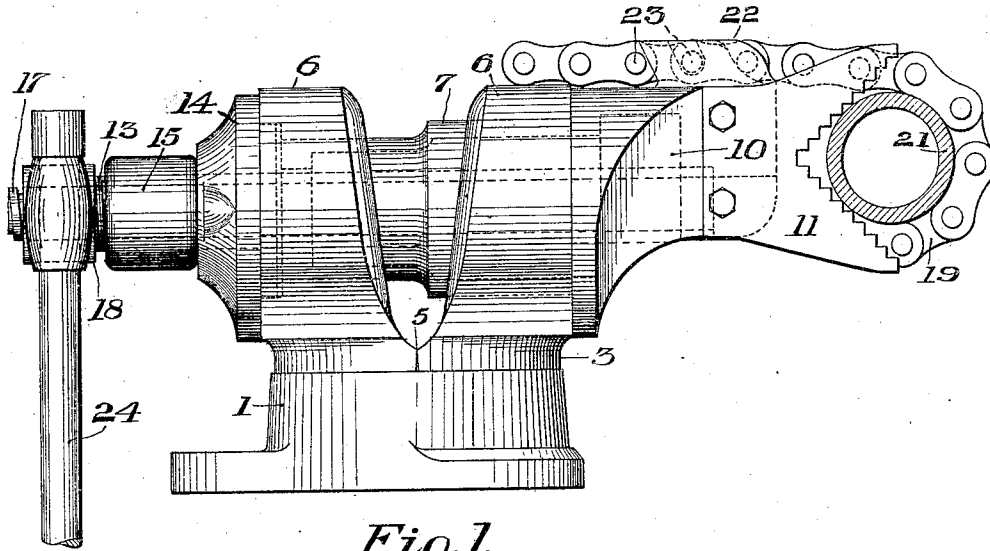

Fig. 1.

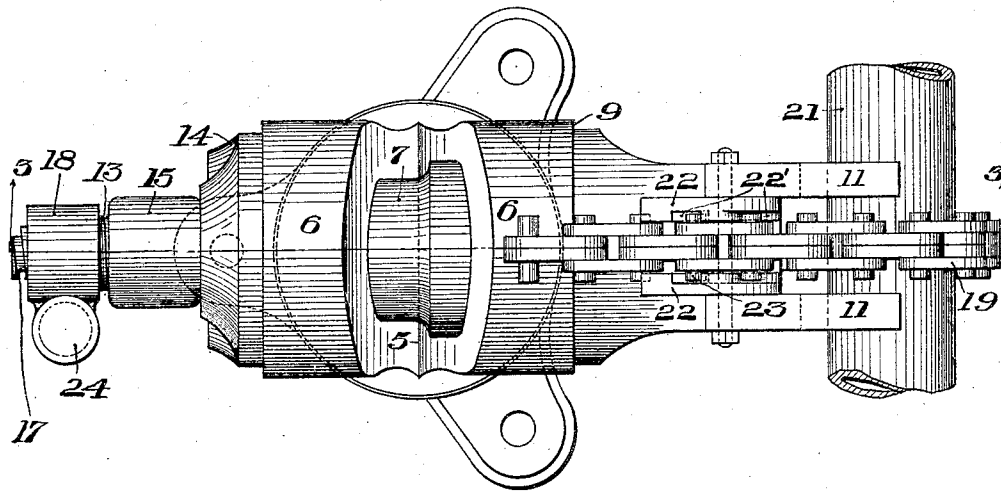

Fig. 2.

WITNESSES

Walter Samaras
O. L. Thompson

INVENTOR

George P. Blackiston
By *J. N. Cooke*
Attorney

No. 877,699.

PATENTED JAN. 28, 1908.

G. P. BLACKISTON.

WISE.

APPLICATION FILED JULY 23, 1907.

2 SHEETS—SHEET 2.

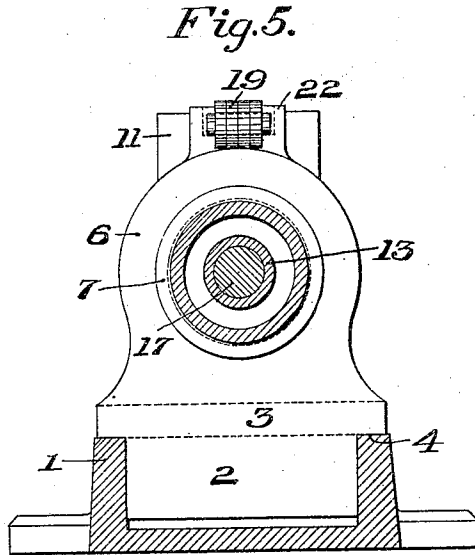
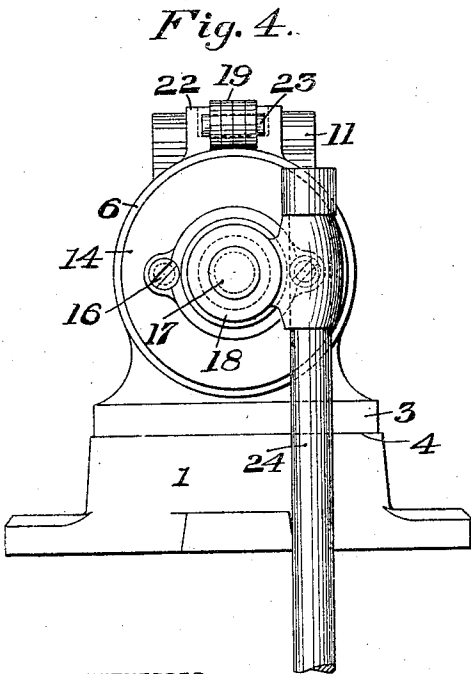
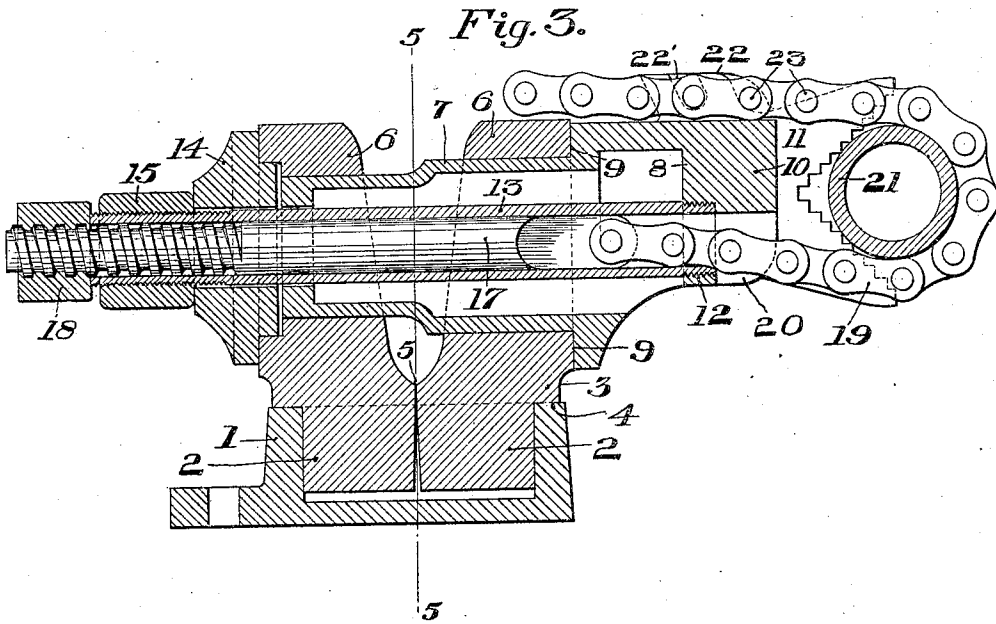

WITNESSES

Walter Samariss
O. L. Thompson

INVENTOR

George P. Blackiston
By J. N. Cooper
Attorney

UNITED STATES PATENT OFFICE.

GEORGE P. BLACKISTON, OF PITTSBURG, PENNSYLVANIA.

WISE.

No. 877,699.

Specification of Letters Patent.

Patented Jan. 28, 1908.

Application filed July 23, 1907. Serial No. 385,218.

To all whom it may concern:

Be it known that I, GEORGE P. BLACKISTON, a resident of Pittsburg, in the county of Allegheny and State of Pennsylvania, have invented a new and useful Improvement in Vises; and I do hereby declare the following to be a full, clear, and exact description thereof.

My invention relates to an improvement in a pipe vise whereby the jaws of a vise may be engaged and an article locked therein independently of the swivels, and the swivels may be engaged and locked without engaging the jaws of the vise, and the jaws or swivels may be disengaged or unlocked each independently of the other, the vise being preferably constructed and operated as hereinafter more fully described, reference being had to the accompanying drawings, in which:—

Figure 1 is a side elevation. Fig. 2 is a plan view. Fig. 3 is a sectional side elevation on line 3—3 of Fig. 2. Fig. 4 is a rear end elevation. Fig. 5 is a vertical section on line 5—5 of Fig. 3.

Like reference numerals in the specification refer to like parts in the drawings, in which 1 is a suitable bearing or support adapted to encircle the hub sections 2 of base 3 which is carried on the shoulder 4 of the said bearing or support 1. The hub sections 2 are faced to normally meet at 5, from which point they diverge sufficient to allow a slight rocking movement of the said sections, the upper portions of which form suitable bearings 6 for the cylindrical body 7 of the jaw-stock 8. On the body 7 is a shoulder 9 which is lodged against the portions 6 for the purpose of preventing any rear movement of the same beyond that point, and a solid head 10 on the sides of which the suitable steel vise jaws 11 are secured. In the solid head 10 and at the rear thereof is a tapped hole 12 (Fig. 3) in which one threaded end of the tube 13 is secured. The other end of said tube extends through the collar 14, in which it is supported, and carries a threaded sleeve 15, the collar 14 being held loosely in position by the screws 16 (Fig. 4).

Within the tube 13 is a screw-bar 17 having a nut 18 at one end thereof, to the other end of which a chain or chains 19 is fixedly secured, the said chain being carried through the opening at 20 in the jaw-stock 8 and open end in the tube 13, and around the pipe 21, as shown in Fig. 3, its other end being remov-

ably fastened in suitable grooves or slots 22' in the lugs 22 which are on the head 10, by means of pins 23 being engaged in the chain and suitable slots in the lugs 22. It will be observed that the sections of the hub 2 are sufficiently free in the cavity of the bearing 1 to allow a revoluble movement of the hub in a horizontal plane, and the cylindrical body 7 is revoluble in its bearings 6 so that a circular movement may be imparted to the jaws 11 of the vise, and the collar 14 is slightly movable on the screws 16.

The operation of the vise is as follows:— With the pipe 21 or other article placed in position in the jaws 11 of the vise, and the chain 19 having been drawn around said pipe and fastened at 22 as previously described, the nut 18 is then tightened or turned by means of a suitable handle 24 against the end of tube 13, thus drawing the screw-bar 17, and thereby putting extreme tension upon the chain 19 and binding the pipe practically immovably in the vise, while leaving the revoluble parts free to be operated at will. To lock the swivels, that is, the hub 2 and body 7 against rotation, the sleeve 15 is tightened on the tube 13 and against the collar 14, thereby drawing the solid head directly back and forcing the collar 14 forward against the bearings 6 rocking said bearings toward each other at that point, and opening the base sections below the meeting point 5 to friction, bind or lock them against the inner wall of the support or bearing 1. If then it is desired to operate the swivels for the purpose of bringing the vise and the article engaged therein to a more convenient position and angle, as is frequently necessary, the sleeve 15 may be loosened on the tube by turning said sleeve back from the position shown in Fig. 1, and toward the nut 18, immediately freeing the swivels without interfering with or loosening the lock on the pipe or other article in the vise which is a great saving of time and labor in that regard. Also, if it is desired to unlock the article in the vise-jaw without loosening the swivels. The same may be done by loosening the nut 18, the lock on the swivels remaining intact. The construction and arrangement of the locking mechanisms may be changed or modified in many respects without departing from the spirit of this invention.

Having described my invention, what I

60
65
70
75
80
85
90
100
105
110

claim as new and desire to secure by Letters Patent is:—

1. In a vise, the combination of locking swivel parts, a jaw, and means for locking an article in the jaw independently of the swivel parts.

2. In a vise, the combination of swivel parts, a jaw, means for locking the swivel parts against rotation, and separate mechanism for locking an article in the jaw.

3. In a vise, a suitable support, a base formed in two separate sections rotatably seated on said support, a jaw rotatable in the upper portions of said sections, mechanism for clamping said jaw, and means for operating the clamping mechanism independently of the rotatable parts of the vise.

4. A vise support having an annular seat, a base with a hub resting in said seat, said hub split centrally in two parts and having substantially flat meeting surfaces, in combination with a jaw having a tubular body rotatably supported in the upper portion of said base, mechanism for clamping an article in said jaw, and means for operating said clamping mechanism independently of the hub and body portions.

5. In a vise, the combination of swivel parts each at right angle to the other, a jaw, means for locking the swivel parts against rotation, and mechanism for locking an article in the jaw.

6. In a vise, the combination of swivel parts each at right angle to the other, a jaw,

means for locking the jaw, means for locking the swivel parts against rotation, and each of said locking means operating independently of the other.

7. A pipe vise comprising a support having a flanged seat, a two part base rotatably resting in said seat and provided with tubular bearings in their top portion, a jaw having a body engaged in said bearings, means for locking an article in the jaw independently of the rotatable base and body portion, and means for locking the rotatable base and body portion independently of the jaw.

8. A pipe vise comprising a support having a flanged seat, a two-part base rotatably resting in said seat and provided with tubular bearings in their top portion, a jaw having a body engaged in said bearings, mechanism adapted to lock each of the revoluble parts, comprising a tube connected to the jaw and supported by a cap at the other end thereof, and a sleeve operating on the tube and against said cap, a screw-bar within the tube and having a nut on one end thereof operating against the end of said tube, and a chain connected to the inner end of the screw-bar and to the jaw.

In testimony whereof, I, the said GEORGE P. BLACKISTON have hereunto set my hand.

GEORGE P. BLACKISTON.

Witnesses:

J. L. TREFALLER, Jr.,
O. L. THOMPSON.