



Europäisches Patentamt
European Patent Office
Office européen des brevets



(11) **EP 0 863 100 B1**

(12) **EUROPEAN PATENT SPECIFICATION**

(45) Date of publication and mention
of the grant of the patent:
30.05.2001 Bulletin 2001/22

(51) Int Cl.7: **B65H 29/46**, B65H 31/30

(21) Application number: **97103809.6**

(22) Date of filing: **07.03.1997**

(54) **Apparatus for the manufacture and stacking of layered cellulose products**

Vorrichtung zum Herstellen und Stapeln von mehrlagigen Zellstoffprodukten

Appareil pour la fabrication et l'empilage de produits cellulosiques multicouches

(84) Designated Contracting States:
**AT BE CH DE DK ES FI FR GB GR IE IT LI LU NL
PT SE**

(74) Representative: **Hübner, Gerd, Dipl.-Phys. et al
Rau, Schneck & Hübner
Patentanwälte
Königstrasse 2
90402 Nürnberg (DE)**

(43) Date of publication of application:
09.09.1998 Bulletin 1998/37

(73) Proprietor: **THE PROCTER & GAMBLE COMPANY
Cincinnati, Ohio 45202 (US)**

(56) References cited:
**EP-A- 0 611 720 DE-A- 19 508 248
FR-A- 2 250 630 GB-A- 794 448
US-A- 1 960 667 US-A- 2 403 394**

(72) Inventor: **Stary, Christof
90542 Eckental (DE)**

EP 0 863 100 B1

Note: Within nine months from the publication of the mention of the grant of the European patent, any person may give notice to the European Patent Office of opposition to the European patent granted. Notice of opposition shall be filed in a written reasoned statement. It shall not be deemed to have been filed until the opposition fee has been paid. (Art. 99(1) European Patent Convention).

Description

[0001] The invention relates to a device for the manufacture and stacking of layered cellulose products and in particular cotton pads as used for cosmetic purposes.

[0002] An apparatus for punching rounds or other shaped parts out of a fibrous material is known from DE-A-30 22 369, in which a punch cooperates with a die. A web of cotton or cotton wool is guided stepwise over the die. With each stepwise advance of the web, the punch performs a punching motion. The punched rounds are transported downwards through the punching die into a pipe passage, through which they are pushed successively. In a subsequent charging station as disclosed in DE-A-43 16 363, partial stacks are separated from the continuous stream of products to be stacked, the number of rounds in a partial stack corresponding to the desired number in a packing unit - for instance a flexible tubular bag.

[0003] The punching apparatus known from DE-A-30 22 369 has the drawback that the raw material web of cellulose or cotton must be stopped for each punching operation. Furthermore, punching is a comparatively rough way of material treatment, which is accompanied with some noise. Moreover, it is inherent in the system that the cutting edges of a punch are highly susceptible to wear.

[0004] As becomes obvious from the separating device according to DE-A-43 16 363, the requirements in terms of equipment are comparatively high in order for a corresponding number of pads to be separated from the continuous flow of punched rounds, then forming a partial stack which is the packing and selling unit. As seen from the prior art, a second web of semirigid plastic material was also guided in the punching machine, from which separating sheets were punched after a number of rounds corresponding to a selling unit had been punched, and were integrated into the stream of products to be stacked.

[0005] In this regard, the handling arrangement for layered cellulose products, in particular cotton pads, according to DE-A-195 08 248 means a certain improvement. This handling arrangement is provided with a temporary storage device which moves the successive cotton pads between a punching machine and a packing station. The temporary storage device has at least one pair of separate chambers for the serial take-up of the cellulose products discharged from the punching machine in a number corresponding to the packing unit and for transferring the cotton pads taken up as a package into a conveying cartridge. The pairs of chambers are to be coupled alternately with the outlet of the punching machine and, respectively, in a transfer station with the respective conveying cartridge.

[0006] With this handling arrangement, there is no continuous stream of products to be stacked, from which partial stacks have to be separated in complicated operation. Rather, a number of cotton pads precisely cor-

responding to the packing unit is supplied to the take-up chamber and transferred as a package to a packing station by means of the conveying cartridges.

[0007] A drawback of the known handling arrangement again resides in that the actual punching operation only takes place with a web moved stepwise. The drawbacks mentioned above apply here, too.

[0008] The closest prior art is US-A-1 960 667, which discloses an apparatus for the manufacture and stacking of layered cellulose products by the cellulose products being cut from a continuous web and by the cellulose products being transferred to a stacking and storing means, comprising:

- 5 - a rotary cutter unit for the continuous, serial cutting of the cellulose products from the continuous web,
- a conveyor belt arrangement, which continuously conveys the cellulose products deposited by the rotary cutter unit, and
- 10 - a transfer station, in which the cellulose products can be lifted off the continuously running conveyor belt arrangement by means of a lifting tappet and can be inserted successively into the stacking and storing means.

[0009] When a rotary cutter unit is used, there is no longer the stepwise advance of the prior art punching machines which limits the capacity. Furthermore, owing to their structure and operation, rotary cutter units are less susceptible to wear than the prior art punching machines, there being no blunt punching impact between punch and die in the case of cutting rolls. At most, rolling cutting contact takes place between the rotary cutting roll and the opposite roll.

[0010] In coordination with the cellulose products continuously produced, the conveyor belt arrangement then conveys the cellulose products likewise continuously with an intermediate step of conveying. Unproblematic access to the cellulose products conveyed is ensured by the use of a conveyor belt arrangement.

[0011] This access takes place in the transfer station mentioned, where the cellulose products can be lifted continuously off the conveyor belt arrangement by means of a lifting tappet. By its lifting motion, the lifting tappet removes the cellulose products from the conveyor belt, pushing them simultaneously into the stacking and storing means. This way of handling ensures that the cellulose products are fed into the stacking and storing means precisely in the number the packing unit is to have.

[0012] FR-A-2 250 630 discloses a device for continuously folding bags, in which the bags are conveyed on a conveyor with a defined number of parallel partial belts, e.g. seven belts. This conveyor is followed by a second conveyor with a smaller number of partial belts, e.g. three belts, to provide for the possibility to fold the bags around the narrower part at the second conveyor.

[0013] Based on the closest prior art of US-A-1 960

667, it is an object of the invention to specify an apparatus by means of which to attain improved production capacity, low susceptibility to wear and the possibility of suitably handling the cellulose products, in particular cotton pads, for subsequent packing. This object is achieved by the characterizing features of claim 1. Accordingly, for each row of cellulose products, the conveyor belt arrangement has two conveyor belts following each other and passing into each other. The first conveyor belt is contiguous to a rotary cutter unit and comprises three partial belts running side by side at a distance. The second conveyor belt comprises two partial belts running side by side at a distance and which, in an overlap portion, run in the spaced gap of the partial belts of the first conveyor belt for the transfer of the cellulose products from the first to the second conveyor belt. The width of the two partial belts of the second conveyor belt is less than the width of the central partial belt of the three partial belts of the first conveyor belt.

[0014] Preferred embodiments as well as further features, details and advantages of the invention will become apparent from the subclaims and the ensuing description in which an exemplary embodiment of the invention is explained, taken in conjunction with the drawings, in which

- Fig. 1 is a lateral view, partially diagrammatic, of an apparatus for the manufacture, transport and stacking of cotton pads,
- Fig. 2 is a highly diagrammatic plan view of the apparatus according to Fig. 1,
- Fig. 3 is a sectional plan view of the conveyor belt arrangement of the apparatus according to Fig. 1 in the vicinity of the transfer station,
- Fig. 4 is a vertical section, parallel to the cotton pads conveying direction, through the transfer station of the apparatus according to Fig. 1 with a lifting tappet and storage pipe, and
- Figs. 5 and 6 are detailed side views of the lifting tappet in the transfer station in the former's lowered and lifted position.

[0015] Reference is made to Figs. 1 and 2 for the explanation of the rough structure of an apparatus according to the invention for the manufacture and stacking of cotton pads 1. The apparatus is split up into a rotary cutter unit 2, a conveyor belt arrangement 3 and two transfer stations 4, 4'. The mentioned components are mounted on a frame-type machine table designated in its entirety by 5 and not needing further explanation.

[0016] The rotary cutter unit 2 serves for the continuous, serial cutting of cotton pads 1 from a continuous web 6 of appropriate cellucotton. The continuous web is fed from a storage roll (not shown) via corresponding guiding and compensating rolls, as is usual prior art. The rotary cutter unit 2 substantially consists of a lower rotary cutting roll 7 and an opposite roll 8 cooperating with the latter. Round cutting edges 9 are formed on the rotary cutting roll distributed over the length of the roll sleeve and its circumference, having the interlocked and staggered configuration shown on the left of Fig. 2. The rotary cutting roll and the opposite roll 7, 8 are set to each other in such a way that clear cutting of cotton pads 1 from the continuous web 6 takes place, with, however, the wear of the cutting edges being minimal. Cutting edge angles of approximately 15° are usual, the distance between the cutting edge 9 and the opposite roll 8 being 0.015 mm. This is conventional technology known from the manufacture of sanitary towels, diapers and the like.

[0017] In a manner likewise known, the rotary cutting roll 7 is provided with a vacuum fixing device which retains the cut cotton pads 1 on the rotary cutting roll 7 during the transfer between the place of cutting - i.e. the roll slit 11 - and the place of deposition on the conveyor belt arrangement 3. Customarily, openings are provided in the sleeve of the rotary cutting roll 7 within the closed cutting edges 9; the openings are in connection with a vacuum source. In this way the cotton pads 1 are sucked up and held in place.

[0018] As opposed to this, the web of waste 10, which remains between the rotary cutting roll and the opposite roll 8 after the place of cutting has been passed, is led away from the roll slit 11 in a straight conveying direction.

[0019] The conveyor belt arrangement extends in the conveying direction F tangentially to the lowest point of the rotary cutting roll 7 and comprises two conveyor belts 12, 13 which pass into each other and follow each other in this direction. The overlapped portion between these two conveyor belts is designated by 14. As seen in the diagrammatic illustration according to Fig. 2, the in each case first conveyor belt 12 for each row 15 of cotton pads 1 is formed by three partial belts 16.1, 16.2, 16.3 running side by side at a distance. Each of the successively produced cotton pads 1 is deposited by the rotary cutting roll 7 on these partial belts 16.1, 16.2, 16.3 by the mentioned vacuum openings, when passing the conveyor belt arrangement 3, being shortly actuated by overpressure within the closed cutting edges 9 so that the cotton pads 1 are virtually "blown off". The conveyor belts 12, 13 are provided with a vacuum fixing device, which will be described in detail below, so that the cotton pads 1 are reliably held thereon and conveyed in a smooth, troublefree condition.

[0020] As seen in Fig. 1, all the partial belts 16.1, 16.2, 16.3 are guided via deflection pulleys 17, 18 at the front and rear end of the conveyor belts 12, in the vicinity of

their lower strand 19 meandering via a compensating pulley 20 and a drive pulley 21. The latter is in connection with a drive motor 22 (roughly outlined) which drives the conveyor belts at a defined speed. By means of a piston-cylinder drive 24, the support structure for the conveyor belts 12 and their deflection pulleys 17, 18 can be pivoted downward, i.e. away from the rotary cutting roll 7.

[0021] As seen in Fig. 2, the conveyor belts 13 which follow the conveyor belts 12 consist of two partial belts 25.1, 25.2, these partial belts 25.1, 25.2, in the overlapped portion 14, running in the spaced gap 26.1, 26.2 between the associated partial belts 16.1 and 16.2 and 16.2 and 16.3, respectively, of the conveyor belts 12. This ensures an absolutely continuous transfer of the cotton pads 1 from the first conveyor belts 12 to the second conveyor belts 13. The width b of the two partial belts 25.1, 25.2 is less than the width B of the central partial belt 16.2 of the three partial belts 16.1, 16.2, 16.3 of the first conveyor belts 13. The distance a of the two outer edges 27 turned away from each other is selected to be clearly smaller than the diameter of the cotton pads 1. If, for instance, this distance a amounts to 70 to 75 % of the diameter D of the cotton pads, edge portions remain, which clearly stand out beyond the outer edges 27 and which are of importance for the handling of the cotton pads 1 in their course through the apparatus according to the invention.

[0022] As seen in Figs. 5 and 6, the partial belts 25.1, 25.2 - as well as the partial belts 16.1, 16.2, 16.3, which is however not shown in the drawing - are provided with openings 28 extending centrally and following each other in the conveying direction F and run on guide rails 29 into which the vacuum passages 30 are integrated. The latter communicate with the openings 28 on the one hand and are joined to a vacuum source on the other so that the cotton pads 1 are reliably and smoothly held on the partial belts 25, 16 by means of this vacuum holding device.

[0023] At their ends, the conveyor belts consisting of the partial belts 25 are likewise guided via deflection pulleys 31, 33, and in the vicinity of their lower strand 33 they are guided via a compensating pulley 34 and a drive pulley 35, as seen in Fig. 1. The deflection pulley 31 located in the overlapped portion 14 consists of individual disks, between which the respective lower strand 19 of the first conveyor belts 12 is guided. Further, connectors 36 disposed on the guide rails 29 are roughly outlined in Fig. 1, which are connected to a vacuum source (not shown in detail) via pressure hoses.

[0024] The specification now turns to the two transfer stations 4, 4', of which only the first transfer station 4 will be explained in detail. The second transfer station 4' is identical with the first.

[0025] As diagrammatically outlined in Fig. 2, in the transfer station 4, storage cartridges 37 are moved by a transporting equipment 38 at an acute angle W relative to the conveying direction F over the rows 15 of cotton

pads 1 approaching on the conveyor belt arrangement 3 in such a way that in each case a storage pipe 39 aligns in the vertical direction with the cotton pad 1 approaching in a row 15. The angle W corresponds to the angle taken by a continuous oblique row 40 by reason of the staggering V within the row 15. One of the storage pipes is shown in Figs. 1, 5 and 6.

[0026] In a position of vertical alignment with the storage pipes 39, lifting tappets 41 are located under the conveyor belts 13, of which only one is shown in Figs. 1, 4, 5 and 6 for reason of clarity. By way of bearing rods 42, the lifting tappets 41 are lodged in a corresponding guide 43 on the machine table 5 displaceably in the vertical direction. Drive takes place by way of a connecting rod 44, which is connected via eccentric levers 45 with a crank drive 46. The crank drive 46 is mechanically connected with the drive motor 48 of the rotary cutting roll 7 by way of an appropriate linkage 47. The coupling ensures a defined adjustable clock frequency of the lifting tappet 41 so that a lifting motion of the lifting tappet 41 is attained that is synchronous with the arriving cotton pads.

[0027] As seen in Figs. 3, 5 and 6, each lifting tappet 41 has three lifting props 49.1, 49.2 and 49.3 lying side by side at right angles to the conveying direction. In a horizontal section, the central lifting prop 49.1 is in the form of a flat cuboid, moving upward between the two partial belts 25.1, 25.2 of the conveyor belts 13, whereas the two lateral lifting props 49.2 and 49.3, which, in a horizontal section, are in the form of a flat segment of a circle, move upward laterally beyond these partial belts. The entire surface outlined by these lifting props 49 is slightly smaller than the surface of the cotton pads 1 so that the respective cotton pad is clearly lifted off the conveyor belts 13 by the lifting motion of the lifting tappet 41 and, as seen in Figs. 4 and 6, is pushed from below into the storage pipe 39 located above. During this lifting off the conveyor belts 13, the cotton pads 1 keep on moving continuously. The oscillatory motion of the lifting tappet 41 runs synchronous with the arriving cotton pads, it being returned into its lower position when the next cotton pad 1 arrives under the opening of the storage pipe 39. The lifting operation then starts again.

[0028] For the cotton pads 1 inserted from below into the respective storage pipe 39 not to fall out downward when the lifting tappet 41 is withdrawn, the lower edge 50 of each storage pipe 39 has a collar 51 directed inward and leaving an opening that is slightly smaller as compared to the surface of the cotton pads 1. The lightweight cotton pads rest on this collar.

[0029] For clearly adjusted stacking of the individual cotton pads 1 to take place, a stop 52 is provided directly behind each lifting tappet 41 in the conveying direction; it corresponds to the contour of the cotton pads 1 and is formed by three bent ribs 53.1, 53.2 and 53.3. Related to the conveying direction F , these ribs 53 are contiguous to the respective props 49 of the lifting tappet 41, but in the active position shown in Fig. 4, they project

upward over the conveyor belts 13. The ribs 53 form in common a contour in the shape of the arc of a circle, the interior radius of which corresponds to the exterior radius of the cotton pads 1. Consequently, the approaching cotton pads 1 are at least slightly decelerated when contacting the stop 52 and the lifting tappet 41 lifts the cotton pads 1 upward in a clearly defined position. This provides for impeccable stacking of the cotton pads 1 within the storage pipe 29.

[0030] As seen in Figs. 1 and 4, three ribs 53 of the stop 52 reside in a multipart foot 54 which is mounted on a vertically displaceable actuating rod 55. The latter is displaceable upward or downward by way of a drive lever 56 so that the stop 52 can be moved from the elevated position seen in Fig. 4 downward below the upper strand 57 of the conveyor belts 13.

[0031] As further outlined in Fig. 1, the fulcrum of the eccentric lever 45 can be lowered downward by means of an adjusting mechanism 58 so that the connecting rod 44 together with the lifting tappet 41 is displaced downward. As a result, the oscillatory motion of the lifting tappet 41 takes place in a portion where the lifting props 49 no longer project over the conveyor belts 13 and no longer reach into the corresponding storage pipe 39. As a result, arriving cotton pads may approach the second transfer station 4', uninfluenced by the first transfer station 4, which is the case when the storage pipes 39 of the storage cartridges 37 in the first transfer station 4 are filled with a desired number of cotton pads 1 for a packing unit. Then this storage cartridge 37 is discharged via the transporting equipment 38 and another storage cartridge 37 is positioned in the transfer station 4. During this time, a storage cartridge 37 is filled in the second transfer station 4.

[0032] By reference to Fig. 4, attention is drawn to some special measures regarding the storage pipe 39. For instance, the transporting equipment 38 for the storage cartridges 37 comprises upper and lower guiding and holding devices 59, 60. A guiding plate 61 is mounted on the lower guiding and holding device 60, preventing the cotton pads 1 from turning up in the vicinity of the transfer stations 4, 4'.

[0033] Furthermore, each storage pipe 39 in the transfer stations 4, 4' is closable to be comparatively pressure-sealed by means of a cover 62 that can be slipped on from above. Placing the cover 62 takes place by an independent piston-cylinder drive 63 on the upper guiding and holding device 59. Each cover 62 has a cover plate 64 which is connected with the piston rod 65 of the piston-cylinder drive 63. By means of an annular seal 66, the cover plate 64 rests on the upper edge of the storage pipe 39. Centrally on the cover plate 64, provision is made for a cylindrical displacer 68 which, in the closed position seen in Fig. 4, projects into the storage pipe 39 by a length which corresponds about to one third of the entire length of the storage pipe 39. It is the purpose of the cover 62, the seal 66 and the displacer 68 that, in particular in the case of an empty or hardly filled

storage pipe 39, back pressure will build up rapidly as soon as a cotton pad 1 is "shot" from below into the storage pipe 39 by means of the lifting tappet 41. If the storage pipe 39 were simply open, then the cotton pad 1 would whirl around uncontrolled within the volume of the storage pipe 39, as a result of which clean stacking would be impossible.

[0034] Summing up, attention must still be drawn to some general advantages of the apparatus according to the invention for the manufacture and stacking of layered cellulose products. For instance, owing to the utilization of a rotary cutting unit instead of a punching machine, the continuous cellulose web can be exploited to a higher degree, because the cutting edges of the rotary cutting roll are by far more filigree as compared with the edges of a punch and can be set more closely. As a result, the surface proportion of the leaving web of waste 10 can be reduced from 36 % in the case of prior art cotton-pad punching to 27 % in the case of an apparatus according to the invention. Further, output capacity can almost be doubled from 250 pads per minute to 440 pads per minute. Finally, rotary cutting is accompanied with substantially less noise than punching with a chamfered punch hitting on a 90° die edge. In this regard, the lifetime of a rotary cutting tool exceeds by far that of a punching tool, there being - as mentioned at the outset - no blunt impact of the cutting edges on the opposite roll in the case of rotary cutting.

Claims

1. Apparatus for the manufacture and stacking of layered cellulose products, in particular of cotton pads (1), by cellulose products (1) being cut out of a continuous web and by the cellulose products (1) being transferred to a stacking and storing means (39), comprising:

- a rotary cutter unit (2) for the continuous, serial cutting of cellulose products (1) from the continuous web (6),
- a conveyor belt arrangement (3), which continuously conveys the cellulose products (1) deposited by the rotary cutter unit (2), and
- a transfer station (4, 4'), in which the cellulose products (1) can be lifted off the continuously running conveyor belt arrangement (3) by means of a lifting tappet (41) and can be inserted successively into the stacking and storing means (39),

characterized in that for each row (15) of cellulose products (1), the conveyor belt arrangement (3) has two conveyor belts (12, 13) following each other and passing into each other, of which

- the first is contiguous to a rotary cutter unit (2)

- and comprises three partial belts (16) running side by side at a distance,
- the second comprises two partial belts (25) running side by side at a distance and which, in an overlapped portion (14), run in the spaced gap (26) of the partial belts (16) of the first conveyor belt (12), for the transfer of the cellulose products (1) from the first (12) to the second conveyor belt (13); and wherein
 - the width (b) of the two partial belts (25) of the second conveyor belt (13) is less than the width (B) of the central partial belt (16.2) of the three partial belts (16) of the first conveyor belt (12).
2. Apparatus according to claim 1, characterized in that the at least one lifting tappet (41) is coupled with the drive (48) of the rotary cutter unit (2) by way of a linkage (47).
 3. Apparatus according to claim 1 or 2, characterized in that each lifting tappet (41) has three lifting props (49), which are disposed side by side at right angles to the conveying direction (F) of the cellulose products (1) and which reach through between, and laterally beyond, the two partial belts (25) of the second conveyor belt (13) and lift the respective cellulose product (1) upward off the conveyor belt (13) and insert it from below into the stacking and storing means (39).
 4. Apparatus according to one of claims 1 to 3, characterized in that a stop corresponding to the contour of the cellulose product (1) is provided directly behind each lifting tappet (41) related to the conveying direction (F) of the cellulose products.
 5. Apparatus according to claim 4, characterized in that the stop (52) can be moved out of the conveying path of the cellulose products (1).
 6. Apparatus according to one of claims 1 to 5, characterized in that the stacking and storing means comprises at least one storage pipe (39), which is to be charged successively from below by the lifting tappet (41), and the upper end of which is closable by a removable cover (62).
 7. Apparatus according to claim 6, characterized in that a displacer (68) is mounted on the cover (62) and reaches into the storage volume of the stacking and storing means (39).
 8. An apparatus according to one of claims 1 to 7, characterized in that a multiplicity of cellulose products (1) is handled in rows (15) running side by side parallel to the conveying direction (F) and in that the stacking and storing means comprises storage pipes (39) corresponding to the number of rows.

9. Apparatus according to claim 8, characterized in that the stacking and storing means is a transportable unit (37) comprising the corresponding number of storage pipes (39).
10. Apparatus according to one of claims 1 to 9, characterized in that two transfer stations (4, 4') to be actuated alternately are provided on the conveyor belt arrangement (3), disposed one after the other in the conveying direction (F).
11. Apparatus according to one of claims 1 to 10, characterized in that a vacuum-actuated fixing device (30) for the cellulose products (1) is allocated to the partial belts (16, 25) of the conveyor belt arrangement (3).

Patentansprüche

1. Vorrichtung zur Herstellung und Stapelung lagenförmiger Zellstoffprodukte, insbesondere von Wattepaden (1), durch Ausschneiden von Zellstoffprodukten (1) aus einer Endlos-Bahn und Überführen der Zellstoffprodukte (1) in einen Stapelspeicher (39) mit:
 - einer Rotationsschneid-Einheit (2) zum kontinuierlichen, seriellen Ausschneiden der Zellstoffprodukte (1) aus der Endlosbahn (6),
 - einer Förderbaineinrichtung (3), die die von der Rotationsschneid-Einheit (2) abgelegten Zellstoffprodukte (1) kontinuierlich abtransportiert, und
 - einer Übergabestation (4, 4'), in der die Zellstoffprodukte (1) von der kontinuierlich laufenden Förderbaineinrichtung (3) mittels eines Hebestößels (41) abhebbar und sukzessive in den Stapelspeicher (39) einschiebbar sind,

dadurch gekennzeichnet, daß die Förderbaineinrichtung (3) für jede Reihe (15) von Zellstoffprodukten (1) zwei aufeinanderfolgende, ineinander übergehende Förderbänder (12, 13) aufweist, von denen

 - das erste an die Rotationsschneid-Einheit (2) anschließt und aus drei mit Abstand nebeneinanderlaufenden Teilbändern (16) besteht,
 - das zweite aus zwei mit Abstand nebeneinanderlaufenden Teilbändern (25) besteht, die in einem Überlappungsbereich (14) im Abstandspalt (26) der Teilbänder (16) des ersten Förderbandes (12) zur Übergabe der Zellstoffprodukte (1) vom ersten (12) zum zweiten Förderband (13) laufen, und wobei
 - die Breite (b) der beiden Teilbänder (25) des zweiten Förderbandes (13) kleiner als die Brei-

te (B) des zentralen Teilbandes (16.2) der drei Teilbänder (16) des ersten Förderbandes (12) ist.

2. Vorrichtung nach Anspruch 1, **dadurch gekennzeichnet, daß** der mindestens eine Hebestößel (41) über eine Getriebeeinrichtung (47) mit dem Antrieb (48) der Rotationsschneid-Einheit (2) gekoppelt ist.
3. Vorrichtung nach Anspruch 1 oder 2, **dadurch gekennzeichnet, daß** jeder Hebestößel (41) drei quer zur Förderrichtung (F) der Zellstoffprodukte (1) nebeneinander angeordnete Hebestempel (49) aufweist, die jeweils seitlich außerhalb und zwischen den beiden Teilbändern (25) des zweiten Förderbandes (13) durchgreifen und das jeweilige Zellstoffprodukt (1) nach oben vom Förderband (13) abheben und in den Stapelspeicher (39) von unten einschieben.
4. Vorrichtung nach einem der Ansprüche 1 bis 3, **dadurch gekennzeichnet, daß** bezogen auf die Förderrichtung (F) der Zellstoffprodukte unmittelbar nach jedem Hebestößel (41) ein der Kontur des Zellstoffproduktes (1) entsprechender Anschlag vorgesehen ist.
5. Vorrichtung nach Anspruch 4, **dadurch gekennzeichnet, daß** der Anschlag (52) aus dem Förderweg der Zellstoffprodukte (1) ausrückbar ist.
6. Vorrichtung nach einem der Ansprüche 1 bis 5, **dadurch gekennzeichnet, daß** der Stapelspeicher mindestens ein von unten durch den Hebestößel (41) sukzessive zu befüllendes Speicherrohr (39) aufweist, dessen oberes Ende durch einen abnehmbaren Deckel (62) verschließbar ist.
7. Vorrichtung nach Anspruch 6, **dadurch gekennzeichnet, daß** am Deckel (62) ein in das Speichervolumen des Stapelspeichers (39) hineinragender Verdrängerkörper (68) angebracht ist.
8. Vorrichtung nach einem der Ansprüche 1 bis 7, **dadurch gekennzeichnet, daß** eine Vielzahl von Zellstoffprodukten (1) in parallel zur Förderrichtung (F) nebeneinander verlaufenden Reihen (15) gehandhabt wird und der Stapelspeicher der Reihenanzahl entsprechende Speicherrohre (39) aufweist.
9. Vorrichtung nach Anspruch 8, **dadurch gekennzeichnet, daß** der Stapelspeicher als transportable Einheit (37) mit der entsprechenden Anzahl von Speicherrohren (39) ausgebildet ist.
10. Vorrichtung nach einem der Ansprüche 1 bis 9, **dadurch gekennzeichnet, daß** zwei abwechselnd

aktivierbare Übergabestationen (4, 4') an der Förderbandeinrichtung (3) in Förderrichtung (F) gesehen hintereinander vorgesehen sind.

- 5 11. Vorrichtung nach einem der Ansprüche 1 bis 10, **dadurch gekennzeichnet, daß** den Teilbändern (16, 25) der Förderbandeinrichtung (3) eine mit Unterdruck arbeitende Fixiereinrichtung (30) für die Zellstoffprodukte (1) zugeordnet ist.

10

Revendications

- 15 1. Appareil destiné à fabriquer et empiler des produits en cellulose multicouches, en particulier des tampons en coton (1), les produits en cellulose (1) étant découpés à partir d'une nappe continue et les produits en cellulose (1) étant transférés vers un moyen d'empilage et de stockage (39), comprenant:
 - 20 - une unité de découpage rotative (2) destinée à découper en série et en continu les produits en cellulose (1) à partir de la nappe continue (6),
 - 25 - un agencement de courroies de transport (3) qui transporte en continu les produits en cellulose (1) déposés par l'unité de découpage rotative (2), et
 - un poste de transfert (4, 4') dans lequel les produits en cellulose (1) peuvent être soulevés de l'agencement de courroies de transport (3) qui se déplace en continu, à l'aide d'un poussoir de soulèvement (41) et peuvent être introduits successivement dans le moyen d'empilage et de stockage (39), caractérisé en ce que pour chaque rangée (15) de produits en cellulose (1) l'agencement de courroies de transport (3) comporte deux courroies de transport (12, 13) qui se suivent et passent l'une dans l'autre, dont
 - 30 - la première est contiguë à l'unité de découpage rotative (2) et comprend trois courroies partielles (16) se déplaçant côte à côte à une certaine distance,
 - 35 - la deuxième comprend deux courroies partielles (25) se déplaçant côte à côte à une certaine distance et qui, dans une position de chevauchement (14), se déplacent dans l'intervalle espacé (26) des courroies partielles (16) de la première courroie de transport (12) afin de transférer les produits en cellulose (1) de la première courroie de transport (12) à la deuxième courroie de transport (13), et dans lequel
 - 40 - la largeur (b) des deux courroies partielles (25) de la deuxième courroie de transport (13) est inférieure à la largeur (B) de la courroie partielle centrale (16.2) des trois courroies partielles (16) de la première courroie de transport (12).

2. Appareil selon la revendication 1, caractérisé en ce qu'au moins un poussoir de soulèvement (41) est couplé au dispositif d'entraînement (48) de l'unité de découpage rotative (2) à l'aide d'une liaison (47).
3. Appareil selon la revendication 1 ou 2, caractérisé en ce que chaque poussoir de soulèvement (41) présente trois appuis de soulèvement (49) qui sont placés côte à côte à angles droits par rapport à la direction de transport (F) des produits en cellulose (1), et qui s'étendent transversalement entre les deux courroies partielles (25), et latéralement au-delà de celles-ci, de la deuxième courroie de transport (13), et soulèvent le produit en cellulose (1) respectif vers le haut à partir de la courroie de transport (13) et l'introduit de dessous dans le moyen d'empilage et de stockage (39).
4. Appareil selon l'une des revendications 1 à 3, caractérisé en ce qu'une butée correspondant au contour du produit en cellulose (1) est prévue directement derrière chaque poussoir de soulèvement (41) associé à la direction de transport (F) des produits en cellulose.
5. Appareil selon la revendication 4, caractérisé en ce que la butée (52) peut être déplacée en dehors du trajet de transport des produits en cellulose (1).
6. Appareil selon l'une des revendications 1 à 5, caractérisé en ce que le moyen d'empilage et de stockage comprend au moins un tuyau de stockage (39) qui doit être chargé successivement de dessous par le poussoir de soulèvement (41), et dont l'extrémité supérieure peut être fermée par un couvercle amovible (62).
7. Appareil selon la revendication 6, caractérisé en ce qu'un élément mobile (68) est monté sur le couvercle (62) et s'étend dans le volume de stockage du moyen d'empilage et de stockage (39).
8. Appareil selon l'une des revendications 1 à 7, caractérisé en ce que plusieurs produits en cellulose (1) sont traités dans les rangées (15) se déplaçant côte à côte parallèlement à la direction de transport (F), et en ce que le moyen d'empilage et de stockage comprend des tuyaux de stockage (39) correspondant au nombre de rangées.
9. Appareil selon la revendication 8, caractérisé en ce que le moyen d'empilage et de stockage est une unité transportable (37) comprenant le nombre correspondant de tuyaux de stockage (39).
10. Appareil selon l'une des revendications 1 à 9, caractérisé en ce que deux postes de transfert (4, 4') qui doivent être actionnés en alternance sont prévus sur l'agencement de courroies de transport (3), placés l'un après l'autre dans la direction de transport (F).
11. Appareil selon l'une des revendications 1 à 10, caractérisé en ce qu'un dispositif de fixation actionné sous vide (30) destiné aux produits en cellulose (1) est assigné aux courroies partielles (16, 25) de l'agencement de courroies de transport (3).

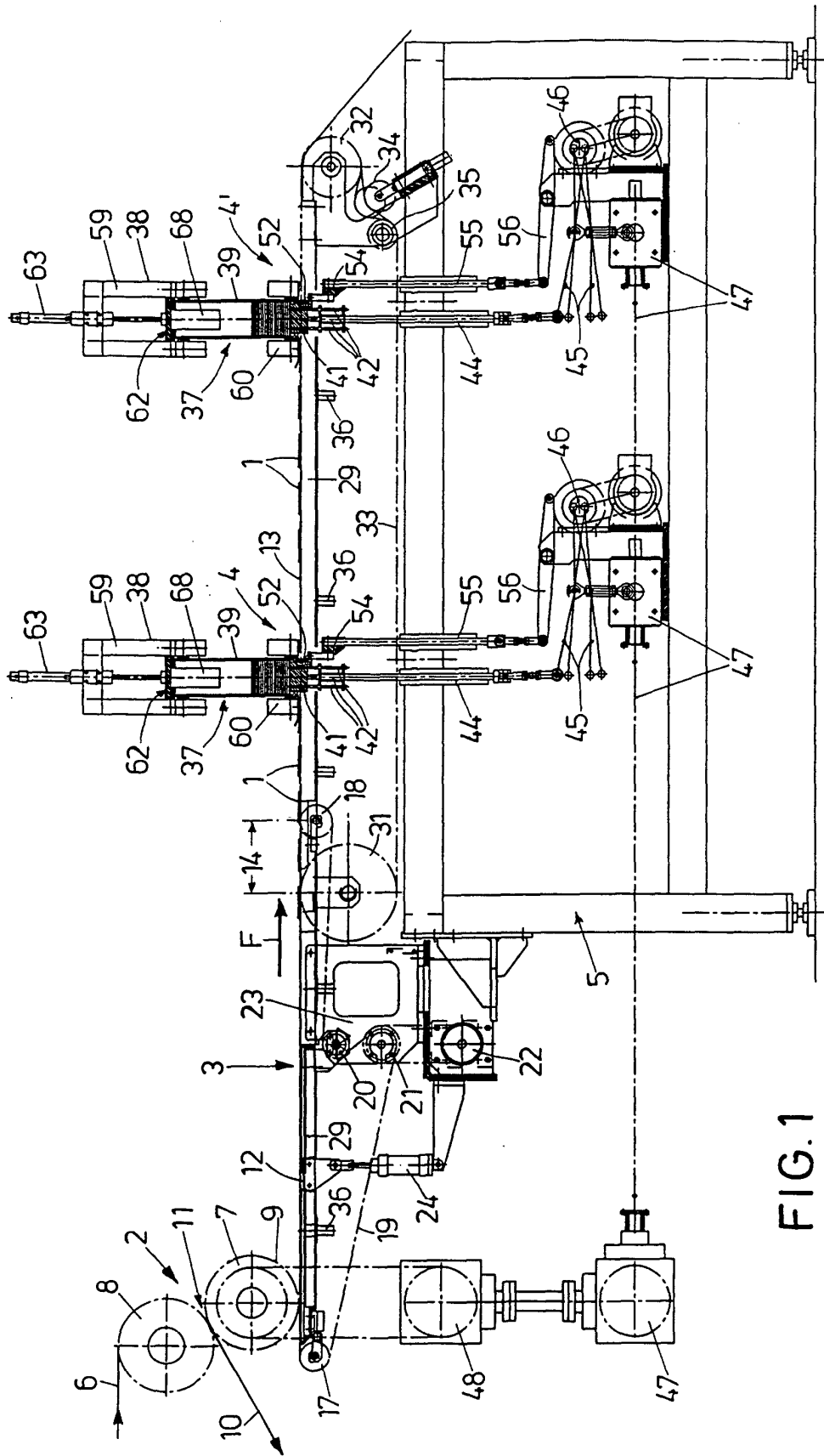
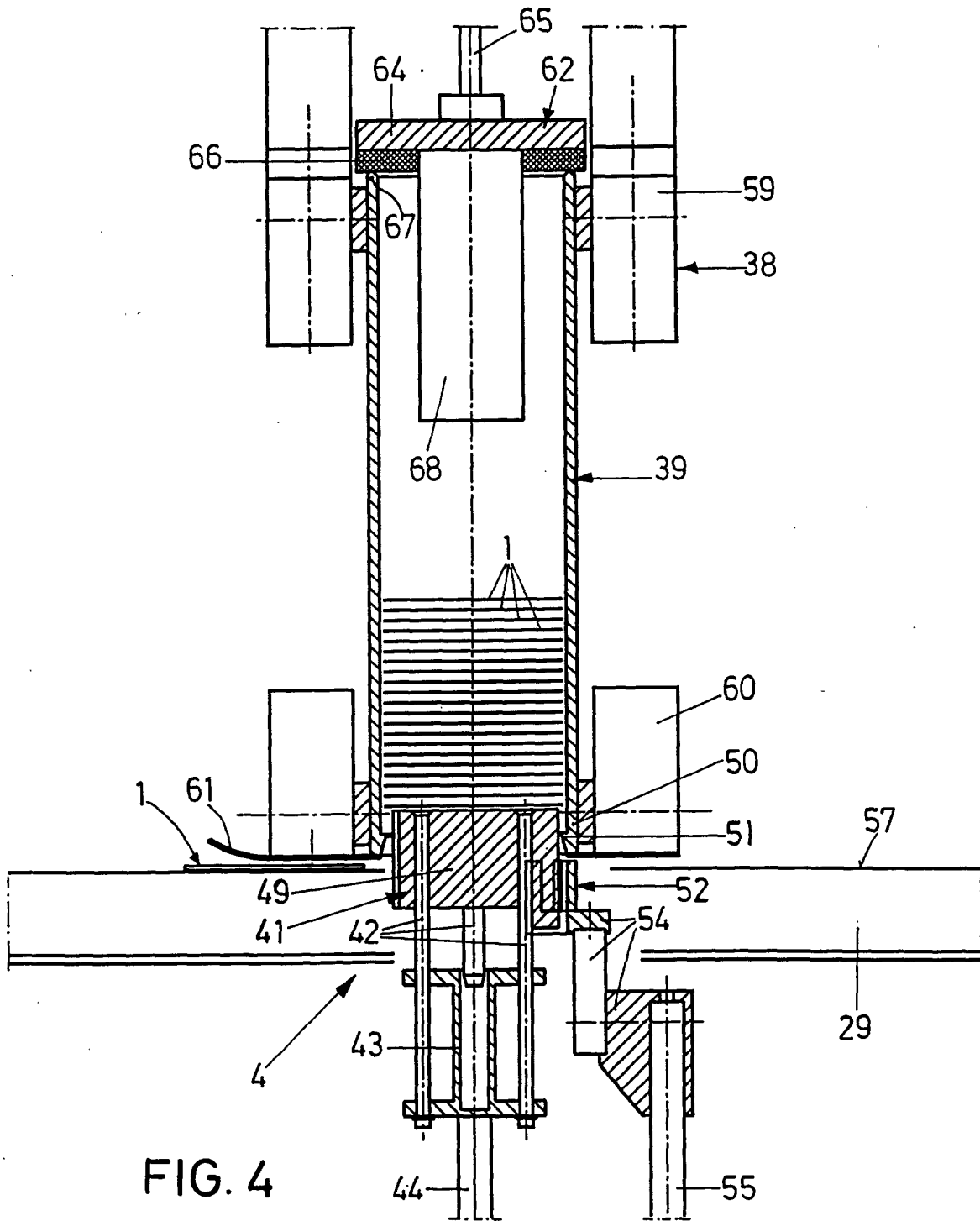

FIG. 1



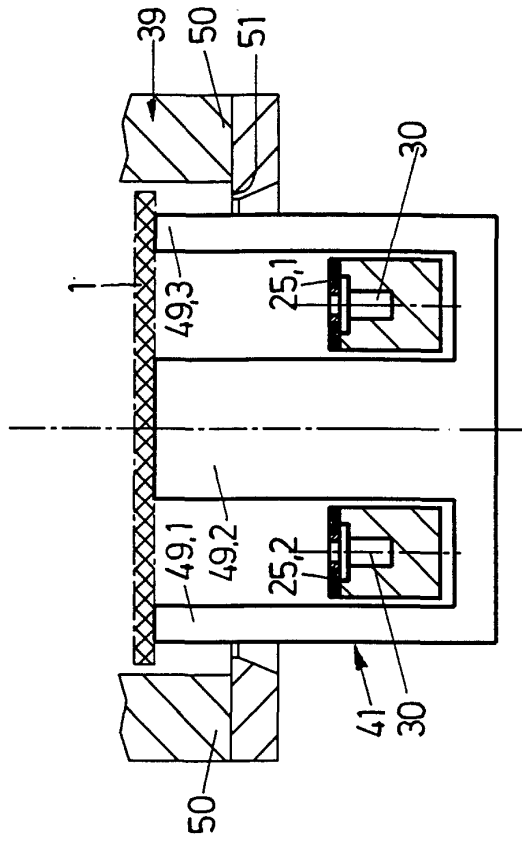

FIG. 6

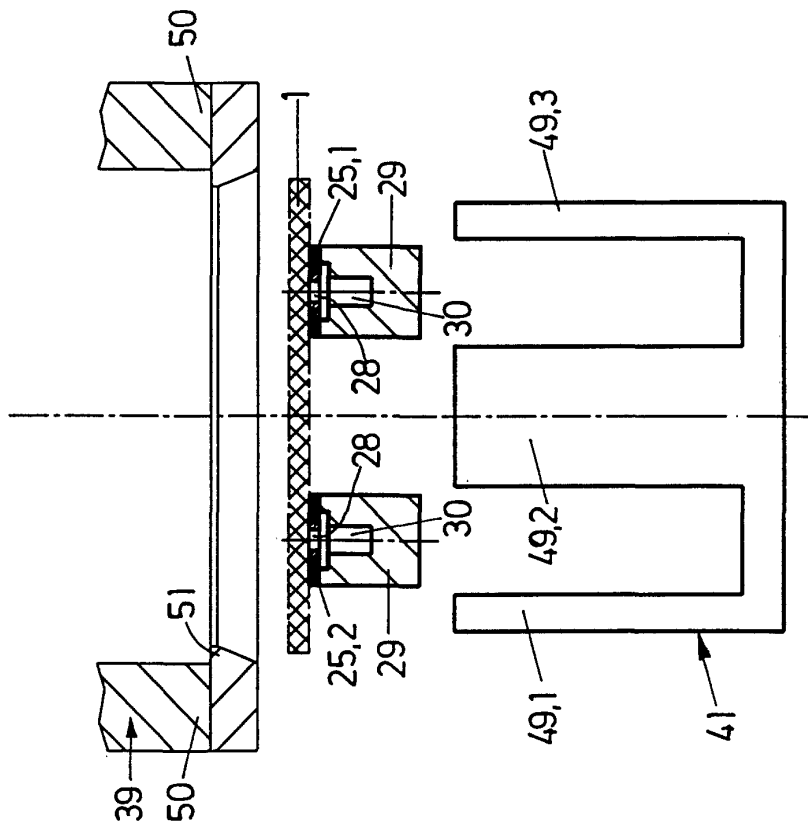

FIG. 5