

EUROPEAN PATENT SPECIFICATION

- ④ Date of publication of patent specification: **15.10.86** ⑤ Int. Cl.⁴: **B 30 B 9/30**
② Application number: **81850246.0**
⑦ Date of filing: **15.12.81**

⑤ A device for dry storage of garbage.

③ Priority: **22.12.80 SE 8009076**

④ Date of publication of application:
30.06.82 Bulletin 82/26

⑤ Publication of the grant of the patent:
15.10.86 Bulletin 86/42

⑧ Designated Contracting States:
AT BE CH DE FR GB IT LI LU NL SE

⑥ References cited:
US-A-3 041 852
US-A-3 206 946
US-A-3 514 969
US-A-3 650 120
US-A-3 702 544
US-A-3 881 408

⑦ Proprietor: **Lundberg, Lars, U:son**
Svedenborgsgatan 7
S-116 48 Stockholm (SE)

⑦ Inventor: **Lundberg, Lars, U:son**
Svedenborgsgatan 7
S-116 48 Stockholm (SE)

⑦ Representative: **Svanfeldt, Hans-Ake et al**
DR. LUDWIG BRANN PATENTBYRA AB Box 1344
Drottninggatan 7
S-751 43 Uppsala (SE)

Note: Within nine months from the publication of the mention of the grant of the European patent, any person may give notice to the European Patent Office of opposition to the European patent granted. Notice of opposition shall be filed in a written reasoned statement. It shall not be deemed to have been filed until the opposition fee has been paid. (Art. 99(1) European patent convention).

Description

Greater and greater hygienic demands are made on today's large-scale kitchens. Certain countries have a legislation which provides that, among other things, the kitchen garbage has to be stored in a refrigerating space. At present this demand is fulfilled by storing packeted garbage in separately constructed cold rooms which keep refrigerator temperature.

The disadvantages of such storage are many. Among other things, special new or additional cold rooms have to be constructed in connection with the kitchen. Another disadvantage is that before being introduced into the cold room the garbage is stored in containers, usually a plastic bag, at room temperature. Not until the container is filled is the garbage packeted or the plastic bag sealed, respectively, and carried to the cold room. The garbage stored at room temperature in this way sends out a disagreeable smell and/or infection.

In large-scale kitchens it is usual to use compacting devices by means of which the garbage is compacted in the garbage container before the latter is transported to the cold room. From US—A—3 650 120 and also from DE—A—200 89 73 it is known to freeze the garbage into blocks — after the addition of water to the garbage should the latter not contain sufficient amounts of water — which requires additional facilities for handling and transportation of the frozen blocks from the compacting and freezing devices to the garbage container. Moreover, the garbage container is maintained at refrigerator temperature (between minus 18° to minus 12°C).

The present invention aims at providing a device for dry storage of garbage under refrigerator temperature conditions avoiding the drawbacks of the known devices. For this purpose, a device for dry storage of garbage according to the preamble of claim 1 (see US—A—3 650 120) is characterised by a refrigerating appliance located in the cabinet in the top thereof for producing refrigerated air and means for supplying the refrigerated air to the garbage within the garbage container. The filled garbage container is transported away from the large-scale kitchen, possibly after a preferred intermediate storing in a conventional refrigerator.

The device according to the invention is sparing of energy and does not take more energy than an ordinary refrigerator as used in large-scale kitchens.

The invention will be explained in more detail below in connection with the attached drawings, in which Fig. 1 shows a front view of a compacting device provided with a device according to the present invention. Fig. 2 shows a longitudinal section of the device shown in Fig. 1, Fig. 3 shows a transverse section along the line III—III in Fig. 2, Fig. 4 shows an embodiment of air channels included in the device according to the invention, and Fig. 5 is a longitudinal section

similar to Fig. 2 of another embodiment of the device according to the invention.

Fig. 1 shows a compacting device which is provided with the device according to the present invention. The compacting device is in the shape of a cabinet, and in the front wall 1 of the cabinet there is a door 2 having a smaller door 3 tiltable outwards for throwing in garbage. At the side of the door 2 there is an operating panel 4 with operating means for controlling the operation of the device. With the door 2 open a garbage container 5, for example in the form of a conventional wheeled garbage car with tall lateral walls, can be moved into or taken out from, respectively, the cabinet. A conventional bag 6 shown in dashed lines is threaded over the brim of the garbage container 5. After moving the garbage container into position within the cabinet the door 2 is closed and garbage is put into the bag 6 through the throwing-in door 3.

Thus, within the cabinet there is a storage-space 7 which is defined by lateral walls 8, 9, a back wall 10, the front wall 1 and a top wall 11. All the walls are heat-insulated. If desired, a heat-insulated bottom wall not shown may also define the storage-space 7 at the bottom.

A compacting device for compacting the garbage in the bag of the garbage container includes a press plate 12 for pressing the garbage against the bottom of the garbage container. The press plate has an outer contour which substantially corresponds to the inner contour of the garbage container 5. Two feed screws 13, 14 are fixedly connected with the press plate 12 by a yoke 15 which is driven by the feed screws via nuts 16, 17 mounted in the yoke. The feed screws 13, 14 are rotated by a common motor 18 by means of a chain and chain wheel system 19. The feed screws 13 and 14 are mounted on the outside of the lateral walls 8, 9 and are each surrounded by a protecting wall 20 and 21, respectively. In Fig. 2 certain parts of the lateral walls have been broken away in the area around the upper portion of the yoke 15 to show the transmission of motion between the feed screws and the press plate 12.

Instead of the arrangement as shown including feed screws, a chain and chain wheel system and a motor for the up and down motion of the press plate 12 in the vertical direction, hydraulic and/or pneumatic systems may, for example, be used for the same purpose.

By operating a knob on the operating panel 4 the press plate 12 moves downwards and compresses the garbage against the bottom of the garbage container 5 and moves automatically up to its starting position. Additional garbage may then be filled into the garbage container 5 if the latter still is not quite filled.

The structure as described up to now is conventional.

According to the invention a refrigerating appliance is arranged at the top of the storage-space. The refrigerating appliance includes a conventional compressor which pumps a refrigerant in a closed circuit including a conventional re-

frigerating plate 22. The air which is adjacent to the refrigerating plate is cooled down and is caused to circulate in the storage-space 7 by means of a fan 23 as well as air channels 24, 25. The air channel 24 consists of a shaped metal sheet 26 running along the lateral wall 8 and extending from the top portion of the storage-space down to the area of the garbage container 5. The air channel 25 is constructed in a similar way and is arranged in the opposite lateral wall 9 of the storage-space. The fan 23 drives cold air down through the channel 24 and sucks up air through the channel 25. In this way the cold air will sweep the garbage as indicated by the arrows shown in the lower part of Fig. 2. Instead of arranging the air channels 24, 25 along opposite lateral walls the channels may be located adjacent each other in the way shown in Fig. 4. The channel supplying refrigerated air preferably extends further down into the storage-space 7 than the channel which sucks up air from the garbage container. By such an arrangement no appreciable supply of heat takes place down towards the garbage in the garbage container when the throwing-in door 3 is opened.

Instead of using one channel for supplying and another for removing air to and from, respectively, the area above the garbage, several channels may supply air to said area and several channels remove air therefrom. In Fig. 3 two additional channels 27, 28 have been drawn in dashed lines. Fig. 5 shows another embodiment of the invention where instead of, or as a complement to, the units 22 to 26 a refrigerating unit 29 is used which pumps a refrigerant in a cooling coil 30 which surrounds the garbage container 5. A supply pipe 31 leads down to the cooling coil 30 and a pipe 32 leads refrigerant away from the cooling coil 30 and returns it to the refrigerating unit 29.

In the embodiments described the refrigerating units are of such capacity that the storage-space 7 in connection with the garbage container 7 will have the character of a refrigerator, the temperature of which is about +5°C.

Claims

1. A device for dry storage of garbage under refrigerator temperature conditions in a cabinet (1, 8—11) which includes a compacting device (12—19) for compacting the garbage, a storage-space (7) for receiving a garbage container (5) and a throwing-in door (3) for the introduction of the garbage in the garbage container, the compacting device being located above the garbage container to compress the garbage therein, characterized by a refrigerating appliance (22; 29) located in the cabinet at the top thereof for producing refrigerated air and means for supplying the refrigerated air to the garbage within the garbage container.

2. A device in accordance with claim 1, characterized in that said means further to a fan (23) comprise air channels (24, 25, 27, 28) extending

along at least one lateral wall of the storage-space (7) from the refrigerating appliance (22) to the area of the garbage container (5), certain of said air channels carrying refrigerated air down towards the garbage container while the remaining channels are drawing air from the garbage container, the supply channels extending further down into the garbage container than the channels for removing the air from the garbage container.

Patentansprüche

1. Vorrichtung zum Trockenlagern von Abfall unter Kühlschrankbedingungen in einem Schrank (1, 8—11), welcher eine Kompaktiervorrichtung (12—19) zum Kompaktieren des Abfalles, einen Lagerraum (7) zum Aufnehmen eines Abfallbehälters (5) und eine Einwerftür (3) zum Einführen des Abfalls in den Abfallbehälter aufweist, wobei die Kompaktiervorrichtung oberhalb des Abfallbehälters zum Zusammenpressen des darin befindlichen Abfalls angeordnet ist, gekennzeichnet durch eine Kühleinrichtung (22, 29) im oberen Bereich innerhalb des Schrankes zum Erzeugen gekühlter Luft und durch Mittel zum Einführen der gekühlten Luft in den Abfall innerhalb des Abfallbehälters.

2. Vorrichtung gemäß Anspruch 1, dadurch gekennzeichnet, daß die Mittel außer einem Ventilator (23) Luftkanäle (24, 25, 27, 28) aufweisen, welche sich mindestens längs einer Seitenwand des Lagersaumes (7) von der Kühleinrichtung (22) aus bis in den Bereich des Abfallbehälters (5) erstrecken, wobei gewisse Luftkanäle die gekühlte Luft nach unten zum Abfallbehälter führen, während die übrigen Kanäle die Luft vom Abfallbehälter absaugen, wobei die Zuführungskanäle weiter hinunter in den Abfallbehälter reichen, als die Kanäle zum Absaugen der Luft vom Abfallbehälter.

Revendications

1. Dispositif pour le stockage à sec d'ordures ménagères, dans des conditions de température de réfrigérateur, dans une armoire (1, 8—11) qui comprend un dispositif de compactage (12—19) pour compacter les ordures, un espace de stockage (7) pour recevoir un conteneur d'ordures (5) et une porte de jetée (3) pour l'introduction des ordures dans le conteneur d'ordures, le dispositif de compactage étant placé au-dessus du conteneur d'ordures pour comprimer les ordures dans celui-ci, caractérisé en ce qu'il comprend un appareil de réfrigération (22; 29) placé à la partie supérieure de l'armoire, pour produire de l'air réfrigéré, et des moyens d'amenée de l'air réfrigéré vers les ordures à l'intérieur du conteneur d'ordures.

2. Dispositif suivant la revendication 1, caractérisé en ce que lesdits moyens, en plus d'un ventilateur (23), comprennent des canaux d'air (24, 25, 27, 28) qui s'étendent le long d'au moins une paroi latérale de l'espace de stockage (7), de

l'appareil de réfrigération (22) à la zone du conteneur d'ordures (5), certains de ces canaux d'air dirigeant l'air réfrigéré vers le bas, vers le conteneur d'ordures, tandis que les autres canaux

aspirent l'air du conteneur d'ordures, les canaux d'amenée se prolongeant plus loin vers le bas, dans le conteneur d'ordures, que les canaux d'évacuation de l'air du conteneur d'ordures.

5

10

15

20

25

30

35

40

45

50

55

60

65

4

Fig. 1

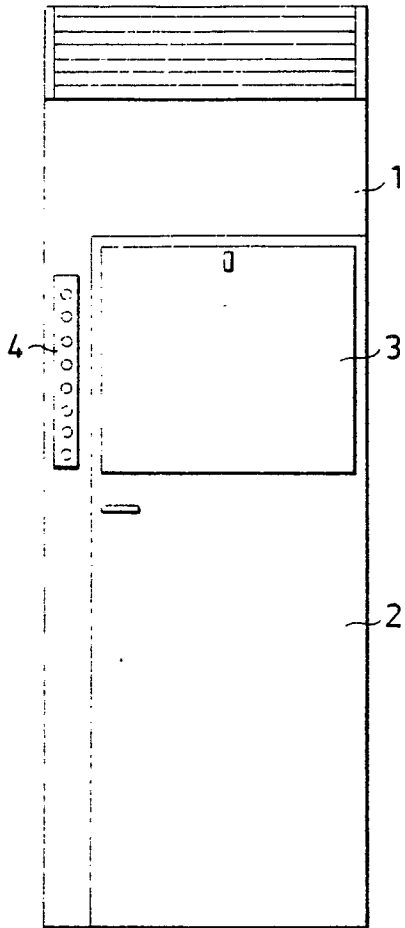

Fig. 2

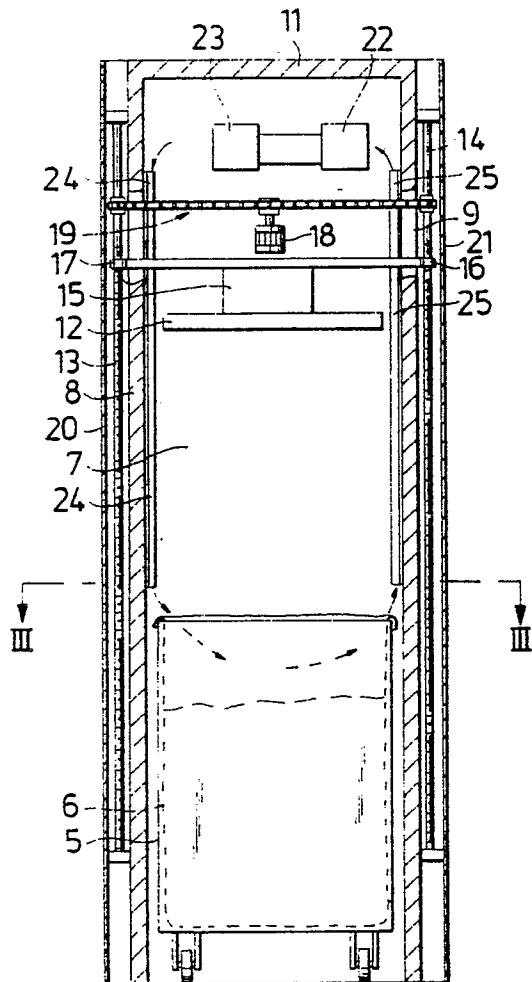

Fig. 3

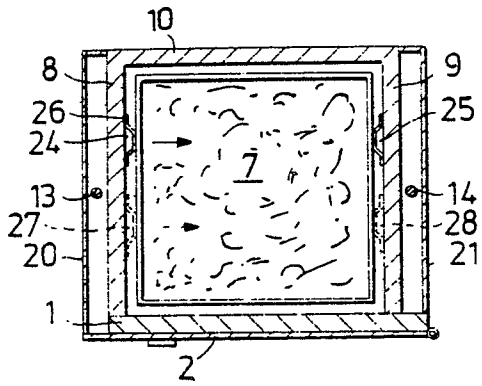

Fig. 4

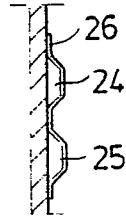

Fig. 5

