

T. SUZUKI.
VERTICAL BOILER.
APPLICATION FILED MAR. 3, 1905.

5 SHEETS—SHEET 1.

Fig. 1.

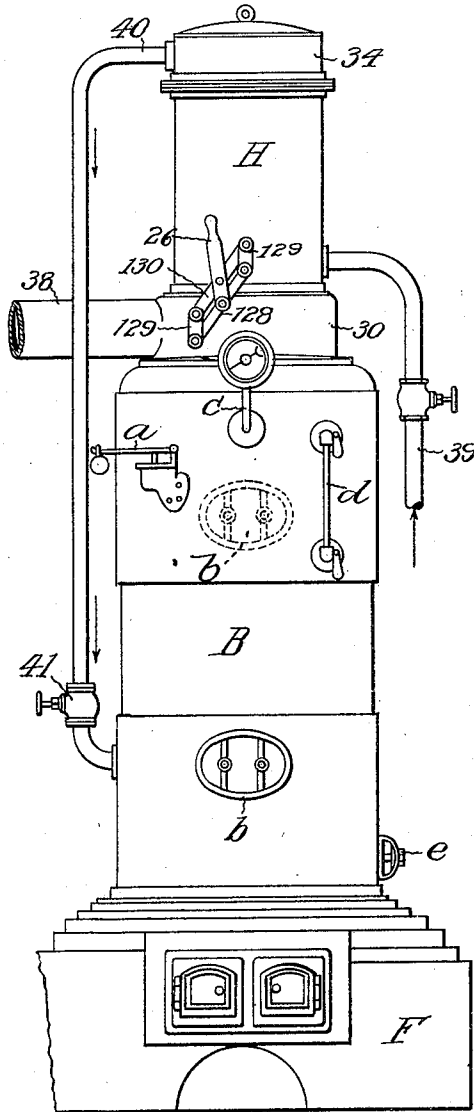
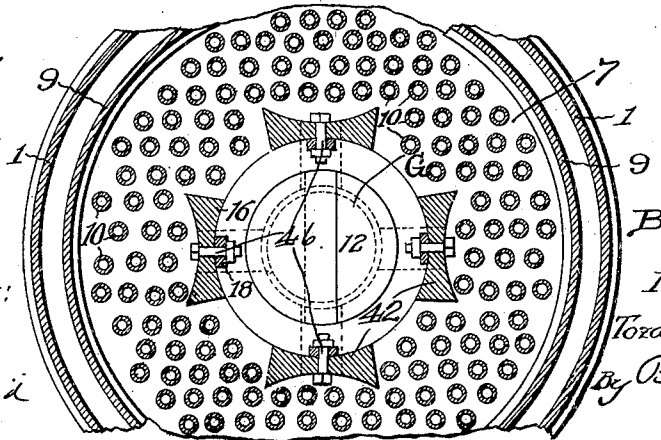

Fig. 3.



Witnesses:
t. Waldman
C. M. Crawford

Inventor:
Toraburo Suzuki
By B. Suzuki
Atty.

T. SUZUKI.
VERTICAL BOILER.
APPLICATION FILED MAR. 3, 1905.

Fig. 2.

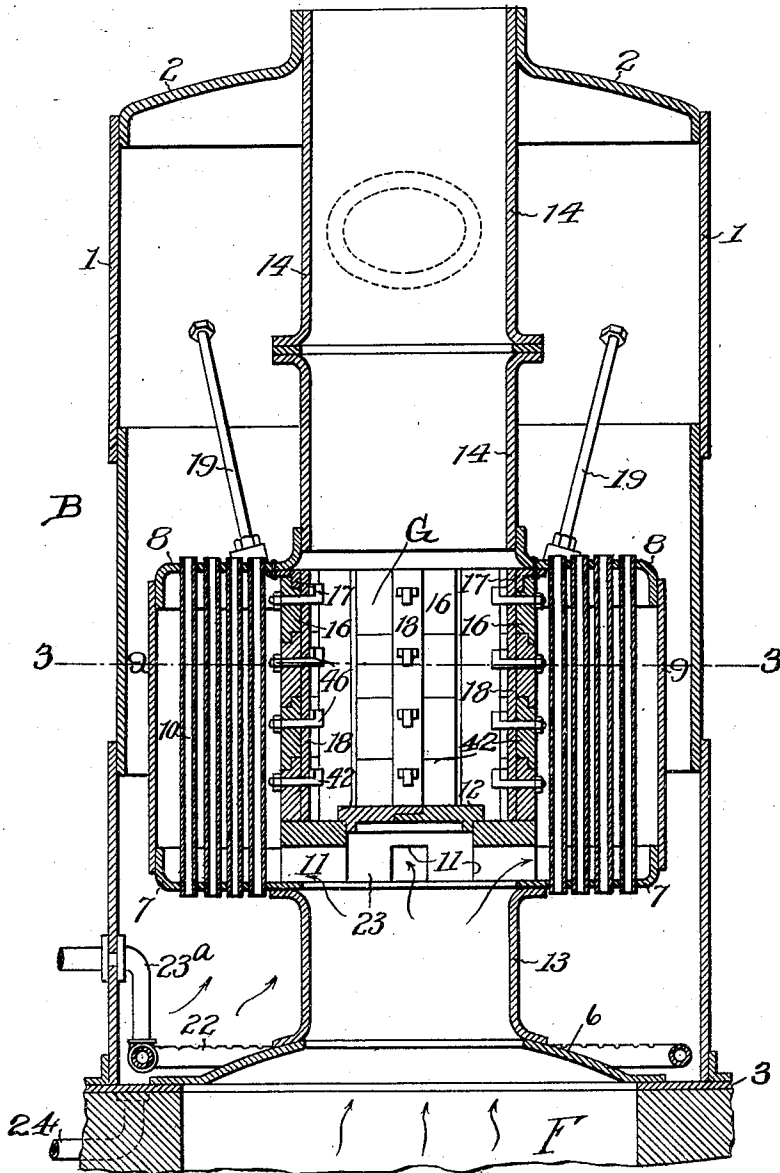

Witnesses:
L. Waldman
C. H. Crawford

Inventor:
Tozaburo Suzuki,
By B. Singer
Att'y.

T. SUZUKI.
VERTICAL BOILER.
APPLICATION FILED MAR. 3, 1905.

Fig. 4.

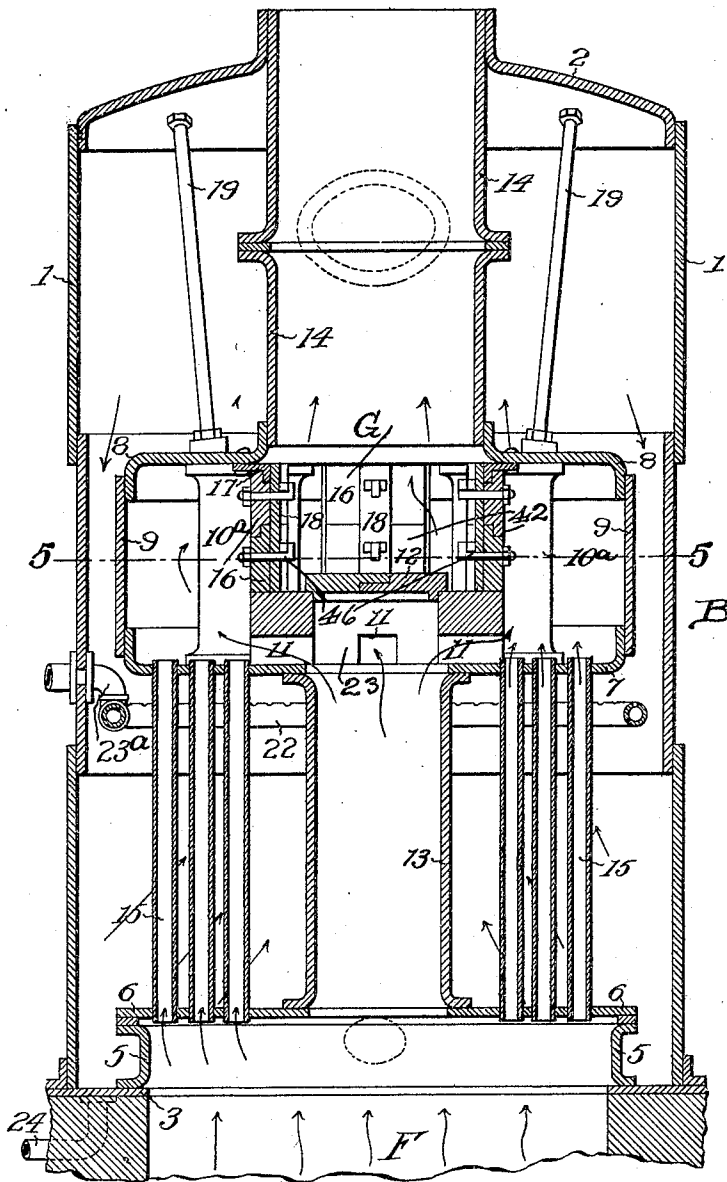

Witnesses:
L. Waldman
C. M. Crawford

Inventor:
Tszaburo Suzuki,
By B. Suzuki
Att'y.

T. SUZUKI.
VERTICAL BOILER.
APPLICATION FILED MAR. 3, 1905.

Fig. 5.

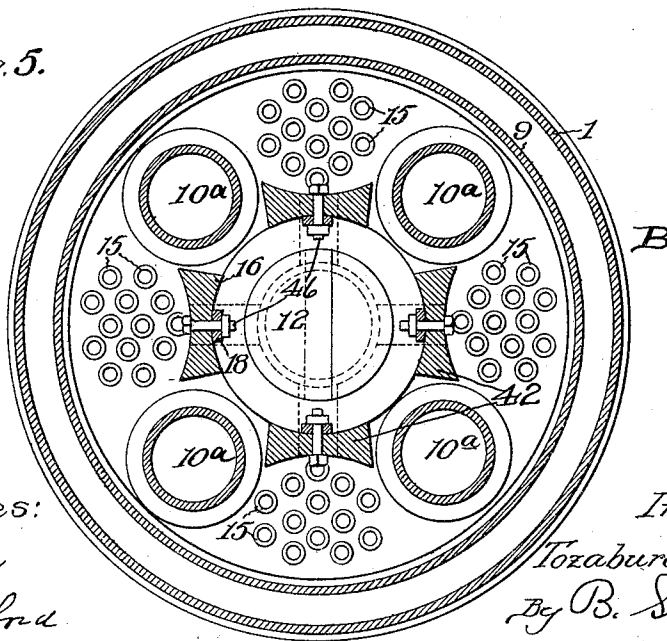

Witnesses:

L. Waldman

C. H. Crawford

Inventor:

Tozaburo Suzuki

By B. Singer

Att'y.

T. SUZUKI.
VERTICAL BOILER.
APPLICATION FILED MAR. 3, 1905.

Fig. 6.

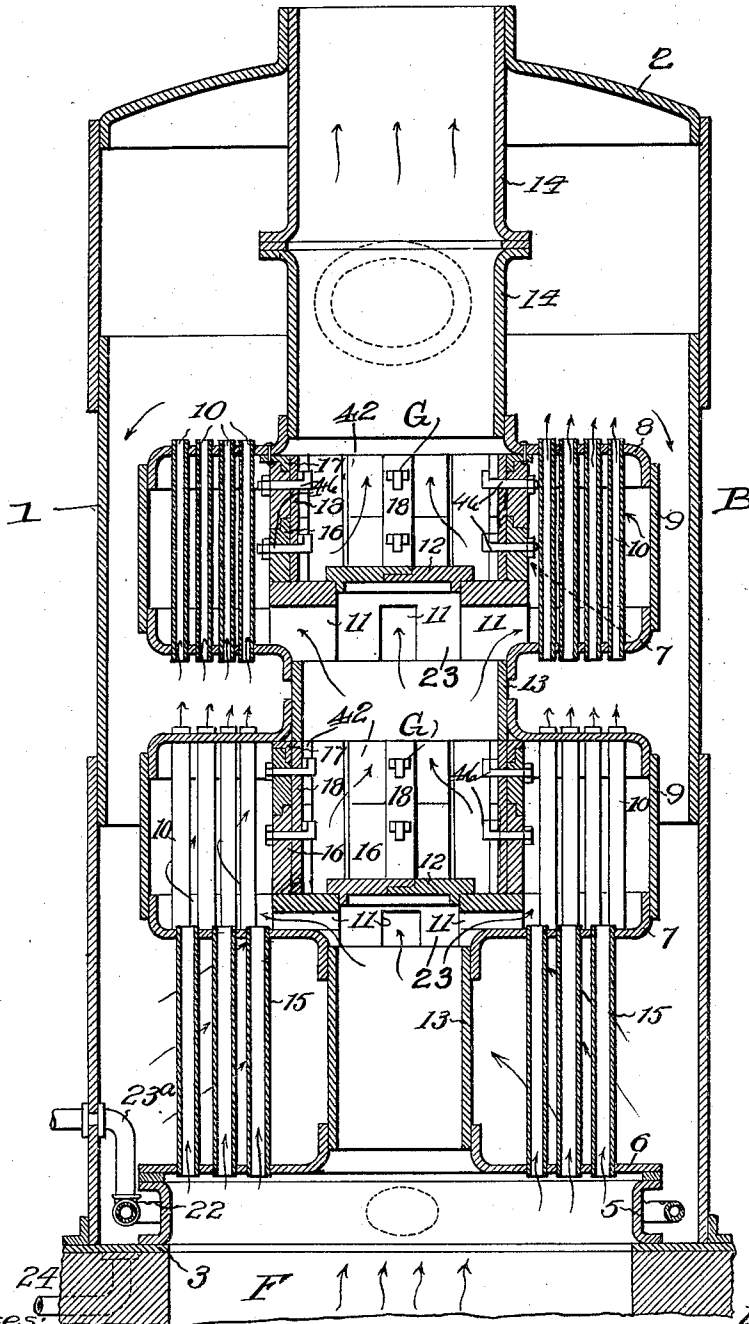

Witnesses:
 L. Waldman
 C. H. Crawford

Inventor:
 Tozaburo Suzuki,
 By B. Suzuki
 Atty.

UNITED STATES PATENT OFFICE.

TOZABURO SUZUKI, OF SUNAMURA, JAPAN.

VERTICAL BOILER.

SPECIFICATION forming part of Letters Patent No. 794,199, dated July 11, 1905.

Application filed March 3, 1905. Serial No. 248,320.

To all whom it may concern:

Be it known that I, TOZABURO SUZUKI, a subject of the Emperor of Japan, residing at No. 401 Jibeishinden, Sunamura, in the county of Minami-Katsushika, in the Province of Tokyo, Japan, have invented certain new and useful Improvements in Vertical Boilers, of which the following is a specification.

My invention relates to improvements in vertical boilers wherein the heat units of the products of combustion are expended on the contents of the boiler through the medium of one or more combustion-chambers, and is an improvement upon the invention disclosed in my application filed June 30, 1904, Serial No. 214,754.

My invention relates more particularly to certain features in the construction of the combustion-chambers, whereby the heat units of the products of combustion passing therethrough may be more fully and completely utilized.

My invention will be more fully described in connection with the accompanying drawings and will be more particularly set forth in the appended claims.

In the drawings, Figure 1 represents a front elevation of boiler embodying the main features of my invention, showing the same supported upon a furnace and also showing a superposed water-heater. Fig. 2 is a vertical section of the boiler shown in Fig. 1, illustrating a portion of the furnace. Fig. 3 is a horizontal section on line 3 3 of Fig. 2. Fig. 4 is a modified form of the boiler shown in Fig. 2. Fig. 5 is a horizontal section on line 5 5 of Fig. 4. Fig. 6 illustrates a further modification of the boiler.

Like characters of reference indicate similar parts throughout the different figures of the drawings.

My invention consists generally, as shown, of a furnace F and a superposed boiler B, provided with a feed-water heater H. The furnace is provided with feeding-doors and desirably discharges directly into the boiler. Said boiler B is provided with manholes b, safety-valve a, steam-gage C, and a water-

gage d. The products of combustion are directed from the furnace upwardly through the boiler and are delivered to the feed-water heater and led therefrom by a suitable outlet 38. Gates are provided with a suitable controlling device 26, whereby the products of combustion may be directed from the boiler to the outlet and whereby the feed-water heater will be thrown into and out of gear with the boiler. A valved feed-water pipe 39 connects directly with the feed-water heater and may communicate with any suitable source of supply. A pipe 40, controlled by a valve 41, leads from the feed-water heater to the boiler, connecting with an annular perforated feed-water pipe 22 therein. Blow-off pipes 24 are provided, whereby the accumulating scale may be carried off in the operation of cleaning the boiler.

I will now refer more particularly to Figs. 2 and 3 and to the special features of construction relating to the combustion-chamber. As herein shown, the boiler consists of an outer shell 1, provided with an imperforate upper wall 2 and a base-ring 3. The base-ring 3 is provided with a central opening equal to the discharge-opening of the furnace, the latter being preferably capped by an annular plate 6, provided with a central opening relatively reduced in size with respect to the discharge-opening of the furnace. The opening of said plate 6 registers with the main flue 13, which delivers at its upper end into a fire or combustion chamber. Said combustion-chamber consists generally of top and bottom closed walls 8 and 7, connected at their margins by an annular wall 9. To the upper end of said closed wall 8 is secured a smoke flue or trunk 14, by means of which the products of combustion are led outwardly through the boiler and delivered to the feed-water heater or direct to an outlet. The walls 7 and 8 are provided with centrally-disposed openings bringing the main flue 13 and smoke-trunk 14 into communication, the said combustion-chamber otherwise being closed to the boiler. Said combustion-chamber comprises a centrally-disposed flame-trunk G, which registers

with the main flue 13 and smoke-trunk 14 and which is closed and opened by means of a damper 12. In the preferred construction the outer wall 9 of the combustion-chamber is of relatively increased diameter with respect to the flame-trunk, and in order to more fully utilize the heat units of the products of combustion the outer portions of the combustion-chamber are provided with water-tubes 10, which permit circulation of water through said chamber. In order that the entire weight of the combustion-chamber may not be wholly thrown upon the main flue 13 and plate 6 and to provide a more rigid mounting for the same, I have shown inclined suspension-rods 19, secured at their opposite ends to the shell of the boiler 1 and the closed wall 8 of the fire-chamber. The flame-trunk is normally closed by a damper 12 to prevent the products of combustion from passing upwardly directly from the main flue to the smoke-trunk, and thereby securing greater efficiency. To this end I provide on the lower wall 7 of the combustion-chamber a flue structure 23, having a central bore on the margin of which the damper 12 is directly supported. Said flue structure is otherwise closed except for radial flues 11, which serve when the damper is closed to receive the products of combustion from the main flue 13 and direct them outwardly against and around the water-tubes 10. It will be understood, however, that because of the relatively restricted size of the bore of the flue structure 23 compared to the flue 13 and flame-trunk G the products of combustion will to a certain extent pass outwardly through the flues 11 when the damper is open; but such outward travel will be relatively limited.

Next, referring more particularly to the construction of the flame-trunk G, whereby access of the products of combustion from the outer portion of the combustion-chamber centrally toward the flame-trunk is permitted, the same in the preferred construction is composed of wall-sections 42, which, as shown, are separated throughout their length in order that the flow of the products of combustion from the outer portions of the chamber to the flame-trunk may not be impeded. It will, however, be obvious that the said flame-trunk may be partially closed in cases where a more restricted travel and a more general circulation of the products of combustion in and around the tubes 10 is desired. In the construction shown the lateral travel of the products of combustion causes a very general circulation about the vertically-disposed tubes 10, serving to encompass said tubes substantially throughout their length. In the preferred construction the separated wall-sections 42 consist of metallic strips 18, suspended from and connected with the upper wall 8 by short strips

of angle-irons 17. Said strips 18 desirably extend from the upper wall 8 downwardly to the flue structure 23 and in the preferred construction are four in number and are located at diametrically opposite points. Each of said strips 18 is flanked on its outer face with a fireproof coating, serving to protect them from direct contact with the products of combustion as they flow into the flame-trunk from the outer portion of the combustion-chamber. By reference to Fig. 2 it will be noted that the strips 18 will not be subjected to direct contact with the flame and heated vapors when the damper is open because of their outward position. Said protective fire-coating consists in the construction shown of a plurality of sections 16, interlocked with each other and supported upon the strips 18 by bolts 46. Said bolts are provided on their outer ends with nuts and on their inner ends with hooked ends adapted for engagement with strips 18.

The construction of the combustion-chamber secures a very general and complete circulation of the products of combustion around the water-tubes and a very complete expenditure of the heat units thereof, the products of combustion being forced to travel in a generally circuitous path without having its progress in any way restricted.

In Figs. 4 and 5 is shown a modified form wherein the annular feed-pipe 22 is located some distance above the main flue 5. In this construction the fire-chamber is not only connected with the main flue 5, leading from the furnace F, by a central flue 13, but also by combustion-tubes 15, which enter the combustion-chamber at points outside the flame-trunk. In this form of the device reliance will not be wholly placed upon the radial flues 11 in order to effect general distribution of products of combustion in the outer portion of the combustion-chamber. I also preferably supplant the fire-tubes 10 of my preferred form of construction with larger tubes 10^a, which possess special advantageous features for furnaces wherein water is used which contains accumulations of foreign matter, the larger tubes being less liable to clog. In this construction it will also be noted that by the addition of the combustion-tubes 15 a large amount of the heat units will be expended upon the contents of the boiler before the general combustion-chamber is reached. The same characters of reference otherwise designate similar parts throughout the figures illustrating this modification.

In Fig. 6 is shown a further modification of the boiler shown in Fig. 4 employing the combustion-tubes 15 and a pair of superposed combustion-chambers. The lower combustion-chamber in this construction is provided with groups of water-tubes 10, which are alternately disposed with respect to the groups

of combustion-tubes 15. In this form the annular perforated feed-pipe 22 is located adjacent the main flue 5.

While I have herein shown and described the specific forms of boilers embodying the main features of my invention, it will be understood that I do not wish to be limited to these precise constructions, as it will be readily seen that they may be materially altered without departing from the spirit of the invention; but

What I claim, and desire to secure by Letters Patent, is—

1. A boiler provided with a furnace, a main flue leading upwardly from said furnace into the boiler, a combustion-chamber within said boiler to which said main flue delivers, a smoke-trunk extending from said combustion-chamber through said boiler to a suitable outlet, said combustion-chamber having a central flame-trunk communicating with said smoke-trunk and main flue, a removable damper for said flame-trunk, radial flues located below said damper conveying the products of combustion laterally, said combustion-chamber having a plurality of water-tubes against which the products of combustion are directed, said flame-trunk being formed of separated walls, permitting the products of combustion to travel inwardly and deliver to the smoke-trunk.

2. A boiler provided with a furnace, a main flue leading upwardly from said furnace into the boiler, a combustion-chamber within said boiler to which said main flue delivers, a smoke-trunk extending from said combustion-chamber through said boiler to a suitable outlet, said combustion-chamber having a central flame-trunk communicating with said smoke-trunk and main flue, a removable damper for said flame-trunk, radial flues located below said damper conveying the products of combustion laterally, said combustion-chamber having a plurality of water-tubes against which the products of combustion are directed, said flame-trunk being formed of separated walls permitting the products of combustion to travel inwardly and deliver to the smoke-trunk when said damper is closed, and suspension-rods secured to said combustion-chamber and boiler and supporting said chamber in position therein.

3. A boiler provided with a furnace, a main flue leading upwardly from said furnace into the boiler, a combustion-chamber within said boiler to which said main flue delivers, a smoke-trunk extending from said combustion-chamber outwardly through said boiler to a suitable outlet, said combustion-chamber having a central flame-trunk communicating with said smoke-trunk and main flue, a removable damper for said flame-trunk, radial flues located below said damper conveying the products of combustion

laterally, said combustion-chamber having a plurality of water-tubes against which the products of combustion are directed, said flame-trunk being formed of separated walls permitting the products of combustion to travel inwardly and deliver to the smoke-trunk when said damper is closed, and an annular perforated feed-water pipe located adjacent said main flue.

4. A boiler provided with a furnace, a main flue leading upwardly from said furnace into the boiler, a combustion-chamber within said boiler to which said main flue delivers, a smoke-trunk extending from said combustion-chamber through said boiler to a suitable outlet, said combustion-chamber having a central flame-trunk communicating with said smoke-trunk and main flue, a removable damper for said flame-trunk, radial flues located below said damper conveying the products of combustion laterally beyond the flame-trunk, said combustion-chamber having a plurality of water-tubes against which the products of combustion are directed, said flame-trunk being formed of separated walls, permitting the products of combustion to travel inwardly and deliver to the smoke-trunk when said damper is closed, and feeding means for the boiler located adjacent said main flue.

5. A boiler provided with a furnace, a main flue leading upwardly from said furnace into the boiler, a combustion-chamber within said boiler to which said main flue delivers, a smoke-trunk extending from said combustion-chamber through said boiler to a suitable outlet, said combustion-chamber having a central flame-trunk communicating with said smoke-trunk and main flue, said combustion-chamber having top, bottom and side walls closed to the boiler, said flame-trunk being formed by a plurality of separated wall-sections suspended from said top wall and terminating a distance above said lower wall, a flue structure supported by said lower wall and engaging the separated wall-sections on their lower ends, said flue structure having laterally-directed flues and a central bore registering with the flame-trunk, and a damper for closing said central bore.

6. A boiler provided with a furnace, a main flue leading upwardly from said furnace into the boiler, a combustion-chamber within said boiler to which said main flue delivers, a smoke-trunk extending from said combustion-chamber outwardly through said boiler, said combustion-chamber having a central flame-trunk communicating with said smoke-trunk and main flue, said combustion-chamber having top, bottom and side walls closed to the boiler, said flame-trunk being formed by a plurality of separated wall-sections suspended from and supported by said top wall and terminating a dis-

- tance above said lower wall a flue structure supported by said lower wall and engaging the separated wall-sections on their lower ends, said flue structure having laterally-directed flues and a central bore registering with the flame-trunk, a damper for closing said bore, and a plurality of water-tubes against which the products of combustion discharged from said lateral flues are directed.
7. A boiler provided with a furnace, a main flue leading upwardly from said furnace into the boiler, a combustion-chamber within said boiler to which said main flue delivers, a smoke-trunk extending from said combustion-chamber outwardly through said boiler, said combustion-chamber having a central flame-trunk communicating with said smoke-trunk and main flue, said combustion-chamber having top, bottom and side walls closed to the boiler, said flame-trunk being formed by a plurality of separated wall-sections suspended from and supported by said top wall and terminating a distance above said lower wall and engaging the separated wall-sections on its upper face, said flue structure having laterally-directed flues and a central bore registering with the flame-trunk, a damper for closing said central bore, a plurality of water-tubes against which the products of combustion discharged from said lateral flues are directed, and suspension-rods secured to said upper closed wall and said boiler and supporting said combustion-chamber in position.
8. A boiler provided with a furnace, a main flue extending up within said boiler, a combustion-chamber to which said main flue delivers comprising upper, lower and side walls closed to the boiler, a smoke-trunk extending up within said boiler, said combustion-chamber having a flame-trunk communicating with said flue and smoke-trunk, said flame-trunk comprising a plurality of separated wall-sections composed of vertically-disposed strips suspended from the upper wall of said combustion-chamber, each of said strips being flanked with fireproof material on their outer sides, said combustion-chamber having a damper adapted to close communication between said flame-trunk and main flue, and having radial flues leading the products of combustion outwardly from said main flue.
9. A boiler provided with a furnace, a main flue extending up within said boiler, a combustion-chamber to which said main flue delivers comprising upper, lower and side walls closed to the boiler, a smoke-trunk extending up within said boiler, said combustion-chamber having a flame-trunk communicating with said flue and smoke-trunk, said flame-trunk comprising a plurality of separated wall-sections composed of vertically-disposed strips suspended from the upper wall of said combustion-chamber, each of
- said strips being flanked with fireproof material on their outer sides, said combustion-chamber having a damper adapted to close communication between said flame-trunk and main flue, and having radial flues leading the products of combustion outwardly from said main flue, and having radial flues leading the products of combustion outwardly from said main flue, said combustion-chamber having water-tubes open to the boiler and against which the products of combustion are directed from said radial flues.
10. A boiler provided with a furnace, a main flue extending up within said boiler, a combustion-chamber to which said main flue delivers comprising upper, lower and side walls closed to the boiler, a smoke-trunk extending up within said boiler, said combustion-chamber having a flame-trunk communicating with said flue and smoke-trunk said flame-trunk comprising a plurality of laterally-separated wall-sections composed of vertically-disposed strips suspended from the upper wall of said combustion-chamber, each of said strips being flanked on their outer sides with a plurality of sections of fireproof material, said sections interfitting and being clamped by bolts to said strips, said combustion-chamber having a damper adapted to close communication between said flame-trunk and main flue, and having radial flues leading the products of combustion outwardly from said main flue.
11. A boiler provided with a combustion-chamber, a central flame-trunk for said chamber, a plurality of water-tubes surrounding said trunk, a removable damper for said trunk, and a plurality of radial flues located below said damper whereby the products of combustion may be directed laterally against said tubes.
12. A boiler provided with a combustion-chamber, a central flame-trunk for said chamber formed of separated walls, a plurality of water-tubes surrounding said trunk, a damper for said flame-trunk, and a plurality of radial flues located below said damper whereby the products of combustion may be directed laterally against said tubes.
13. A boiler provided with a combustion-chamber, a central flame-trunk for said chamber formed of separated walls, each wall comprising a pendent strip of metal having an outer coating of fireproof material, a plurality of water-tubes surrounding said trunk, radial flues for said chamber, and a damper for said trunk serving to direct the products of combustion laterally through the flues against said tubes.
14. A boiler provided with a combustion-chamber, a central flame-trunk for said chamber formed of separated walls, each wall comprising a pendent strip of metal having an outer coating of fireproof material, a plurality of water-tubes for said chamber, and radial flues for carrying the products of combustion outwardly in said chamber.

15. A boiler provided with a combustion-chamber, a central flame-trunk for said chamber provided with openings, a plurality of water-tubes for said chamber, and radial
5 flues for carrying the products of combustion outwardly in said chamber.

16. A boiler provided with a combustion-chamber, a central flame-trunk for said chamber provided with openings, a plurality
10 of water-tubes for said chamber, radial flues

for carrying the products of combustion outwardly in said chamber, and means for closing the flame-trunk between said flues and openings.

In testimony whereof I affix my signature 15
in presence of two witnesses.

TOZABURO SUZUKI.

Witnesses:

UHACHI TSHIWARA,
GEUJI KURIBARA.