

(19)



(11)

**EP 4 017 217 B1**

(12)

**EUROPEAN PATENT SPECIFICATION**

(45) Date of publication and mention of the grant of the patent:  
**18.06.2025 Bulletin 2025/25**

(51) International Patent Classification (IPC):  
**H05B 6/64 (2006.01)**

(21) Application number: **20214693.2**

(52) Cooperative Patent Classification (CPC):  
**H05B 6/6408; H05B 6/6494**

(22) Date of filing: **16.12.2020**

**(54) COOKING ACCESSORY, DIELECTRIC COOKING APPLIANCE, AND KIT OF PARTS**

KOCHZUBEHÖR, DIELEKTRISCHES KOCHGERÄT UND TEILESATZ

ACCESSOIRE DE CUISSON, APPAREIL DE CUISSON DIÉLECTRIQUE ET KIT DE PIÈCES

(84) Designated Contracting States:  
**AL AT BE BG CH CY CZ DE DK EE ES FI FR GB GR HR HU IE IS IT LI LT LU LV MC MK MT NL NO PL PT RO RS SE SI SK SM TR**

• **RODRIGUEZ CEPEDA, Pablo**  
**91541 Rothenburg ob der Tauber (DE)**

(43) Date of publication of application:  
**22.06.2022 Bulletin 2022/25**

(74) Representative: **Electrolux Group Patents**  
**AB Electrolux**  
**Group Patents**  
**S:t Göransgatan 143**  
**105 45 Stockholm (SE)**

(73) Proprietor: **ELECTROLUX APPLIANCES**  
**AKTIEBOLAG**  
**105 45 Stockholm (SE)**

(56) References cited:  
**WO-A1-2016/192802 DE-A1- 102014 104 796**  
**US-A- 5 466 917 US-A1- 2002 000 438**

(72) Inventors:  
• **MAZZON, Claudio**  
**91541 Rothenburg (DE)**

**EP 4 017 217 B1**

Note: Within nine months of the publication of the mention of the grant of the European patent in the European Patent Bulletin, any person may give notice to the European Patent Office of opposition to that patent, in accordance with the Implementing Regulations. Notice of opposition shall not be deemed to have been filed until the opposition fee has been paid. (Art. 99(1) European Patent Convention).

## Description

**[0001]** The underlying invention is directed to a cooking accessory, a dielectric cooking appliance, and a kit of parts.

**[0002]** Document WO 2018/202376 A1 describes a microwavable tray comprising a plurality of microwavable susceptor blocks embedded in a substrate layer forming the tray. The susceptor blocks are provided for compensating uneven distribution of microwave energy inside the microwave cavity of a microwave appliance.

**[0003]** Document WO 90/15710 A1 describes a tray that may comprise different pre-defined compartments for placing food items therein. The tray comprises a baseplate with metal susceptor elements embedded in the baseplate. The susceptor elements are made by metallization and have gradations in resistivity and optical density to produce different amounts of heat in different areas of the tray.

**[0004]** Document EP 3 095 297 B1 describes a microwavable wire tray for a microwave oven, comprising a plurality of rods fixed to a circumferential frame. The rods are made of microwave absorbing material or comprise a bushing made of a microwave absorbing material. The wire tray comprises several groups of neighbouring rods with the rods or bushings of different groups are made of different material compositions such that different temperatures may be provided on the wire tray while being irradiated with microwaves.

**[0005]** Document US 5,466,917 A describes a sheet-like heat generation body for use in a microwave oven, which absorbs microwave and generates heat to irradiate food to be cooked. This heat generation body comprises a conductive film, which is made of a crystalline carbon as its principal component, and is formed on a sheet-like base material. The heat-generating body is prepared using a heat-resistant base material and an inorganic bonding agent applied to its surface. A heat-resistant base is coated with a mixture of a microwave-absorbing and heat-generating material as its principal component and an agent for hardening an inorganic bonding agent to be applied later. After the mixed agent is dried, it is impregnated with the inorganic bonding agent.

**[0006]** DE 10 2014 104 796 A1 describes a cooking accessory for a cooking appliance for heating a cooking product, in particular by contact. This cooking accessory is according to the preamble of claim 1. The cooking accessory has a heating section which can absorb microwave radiation and convert it into heat, the heating section is circular and has, in the frequency range used by a microwave source of the cooking appliance, only a resonant frequency with a resonant peak which has a half-value width of less than 40 MHz, in particular less than 20 MHz.

**[0007]** WO 2016/192802 A1 describes a baking tray for microwave ovens comprising a body, the body is made of a refractory material, has a support surface for a food product, and partially filled with a composite microwave

heatable material comprising a matrix of a refractory material and particles of a susceptor material dispersed within the matrix. The composite material is arranged in the body in a plurality of distinct circular blocks spread beneath the support surface parallel to it, with the amount of susceptor material in the blocks being variable.

**[0008]** In general, in dielectric cooking using electromagnetic radiation in the radio frequency or microwave frequency range, absorption of the radiation is an essential aspect with regard to food quality and heating or cooking efficiency. Albeit some of the above solutions provide some means for influencing radiation absorption in microwave heating, there seems to exist further need for alleviating and supporting users in obtaining improved cooking results in dielectric heating cooking of food or food items, in particular with regard to cooking complex meals or dishes.

**[0009]** It is therefore an object of the invention to provide a cooking accessory, a dielectric cooking appliance and a kit of parts that provides and supports a user in obtaining improved cooking results in dielectric heating or cooking of foodstuff, in particular with regard to different kind of foodstuff and/or different types of dishes. Further, a cooking accessory, a dielectric cooking appliance and a kit of parts shall be provided that allow for improved heating or cooking, in particular improved cooking results for different kinds of foodstuff and/or different types of dishes prepared simultaneously in a cooking cavity by dielectric heating or cooking. In particular, a cooking accessory, a dielectric cooking appliance and a kit of parts shall be provided that allow for improved cooking flexibility required for example for cooking or preparing complex dishes including different types or items of food.

**[0010]** This object is solved by the subject matter of each of the independent claims. Embodiments of the invention result from the dependent claims and the below description of exemplary embodiments.

**[0011]** According to an embodiment, a cooking accessory for high-frequency dielectric heating, in particular cooking, is provided.

**[0012]** The term high-frequency dielectric heating and/or cooking shall in particular mean that the heating and/or cooking is based on dielectric effects obtained by irradiating items with high frequency (HF) electromagnetic radiation (EMR), in short HF EMR. The HF EMR may be in the radio frequency (RF) or microwave frequency (MW) range.

**[0013]** The cooking accessory according to one embodiment is configured for placement in a dielectric heating cavity of a cooking appliance, and suitable for supporting one or more food items thereon while being irradiated with high-frequency electromagnetic radiation for heating the one or more food items in the heating cavity.

**[0014]** In this respect, the cooking accessory may be considered as a microwavable cooking accessory. However, the underlying invention is not restricted to

MW but is as well applicable to RF. The cooking appliance may for example be a microwave and/or radiofrequency oven of appliance, in particular an oven or appliance for domestic use, or an appliance, in particular a household appliance, configured for providing microwave and/or radiofrequency heating and/or cooking of foodstuff such as one or more food items.

**[0015]** A food item shall be understood as including one or more items of food. The items of food may be or comprise comestibles of any kind or composition suitable for being heated or cooked based on HF EMR as mentioned above.

**[0016]** The food item may be provided and placed on the cooking accessory, specifically on a 2D support area thereof, together with one or more parts of cookware as desired. The food item may be accommodated in or on the cookware, for example a plate, a dish, pot, glass, or similar. It is, however, also possible that the food item is positioned directly on the cooking accessory, i.e. the 2D support area thereof.

**[0017]** The cooking accessory comprises a susceptor arrangement with susceptor elements, in particular a plurality of susceptor elements, arranged to span a tiled 2D support area for the one or more food items. The number of susceptor elements may be 2, 3, 4 etc., i.e. an integer. The term "tiled" in particular shall mean, that the susceptor elements define a kind of tile, patch, or pad which, when arranged side-by-side, span a 2D (i.e. a two-dimensional) area or surface. In particular, the upper sides of the susceptor elements may span the 2D support area, wherein the term "upper" refers to the side where the food item is to be placed in ordinary use.

**[0018]** The 2D support area may be configured to receive and support the one or more food items, for example during heating and/or cooking, i.e. while being irradiated with the HF EMR in the cavity. In particular, the susceptor elements comprised by the susceptor arrangement may span the 2D support area, in particular surface, on which one or more food items can be placed while being irradiated with the HF EMR in the heating and/or cooking cavity.

**[0019]** The cooking accessory may for example be constructed or designed as a kind of tray. The cooking accessory may be adapted to accommodate the susceptor elements according to a predefined mutual orientation and mutual alignment to define, by this, a tiled arrangement spanning the tiled 2D support area. As mentioned, each of the susceptor elements may represent or define a tile, patch or pad defining a corresponding 2D portion of the 2D support area.

**[0020]** The 2D support area may form a contiguous planar area or layer defined by an upper face or upper side (a side facing upwards, in particular towards the food item, in ordinary use). In other examples, the 2D support area may be discontinuous, with the susceptor elements being mutually separated by (small) joints or gaps, in particular but not restricted to joint gaps.

**[0021]** In the susceptor arrangement, each susceptor

element has a pre-defined, in particular a selected pre-defined, dielectric absorption characteristic for the high-frequency electromagnetic radiation. The absorption characteristic may for example relate to the reflectivity or absorptivity of the susceptor element for the HF EMR. In particular, the term "absorption characteristic" as used herein shall refer to the absorptivity, the transmittivity, or the reflectivity.

**[0022]** As such, a susceptor element may have a substantially uniform absorption characteristic. The absorption characteristic may, however, also vary over the dimension of the susceptor element according to a pre-defined pattern. The absorption characteristic may for example be related to and measured based on the transmission or absorption coefficient or level.

**[0023]** It shall be noted that the absorption characteristic may be substantially constant across the susceptor element or may vary across the susceptor element in a pre-defined manner. As an example, the susceptor element may be made from a single material and form a substantially homogeneous body with substantially equal absorption characteristic across the susceptor element. In embodiments, the absorption characteristic may vary across the susceptor element. As an example, the absorption characteristic may vary in that the absorption or transmission coefficient or property is a function of the position on the susceptor element. For example, respective sections may comprise strips, circles, or circular rings. Further, the absorption characteristic may vary in that the absorption, transmission or reflection coefficient (absorptivity, transmittivity, reflectivity), is different for different frequencies or energies of the HF EMR. In particular, the absorption characteristic may be frequency-dependent for the HF EMR supplied by the oven, i.e. a HF EMR source configured for supplying the HF EMR into the cavity.

**[0024]** As such, one or more of the susceptor elements may include frequency-selective surfaces with the overall or alternatively the local absorption, transmission, or transmission coefficient is a function of frequency. In other examples, the susceptor element may comprise one or more resonant structures respectively selective for one or more particular HF EMR frequencies. Frequency selectivity may involve one or more minima or maxima of absorptivity, transmittivity, or reflectivity, or respective sections, over the range or a part of the HF EMR range provided by the HF EMR source.

**[0025]** The suggested cooking accessory has the advantage that, by selecting suitable susceptor elements to form the susceptor arrangement and 2D support area, the HF EMR may be applied in a selective manner, in particular in a locally selective. By this, food items placed together within the cavity may be heated or cooked differently, which is advantageous for cooking complex meals, for example.

**[0026]** The susceptor element may absorb the HF EMR and heat up such that heat can be transferred from the cooking accessory to the food item. Further, the

susceptor element may reflect a substantial amount of the HF EMR for absorption by the food item placed thereon. By this, the total amount of HF EMR absorbed in the food item may be influenced, in particular altered, specifically, increased. If the susceptor element is substantially transparent, the effect of the HF EMR substantially corresponds to ordinary HF EMR absorption in the food item.

**[0027]** In case that, according to an embodiment, the absorption characteristic varies or may be altered by a user by rearranging or exchanging one or more susceptor elements, more flexibility with regard to heating or cooking food in the cavity may be obtained. In particular, the cooking accessory provides a possibility that allows a user to heat foodstuff and food items purposefully differently, for example by placing the food items on different tiles respectively defined by a susceptor element of the cooking accessory having different absorption characteristics, respectively. The cooking accessory may therefore provide improvements with regard to purposeful non-uniform heating, which is advantageous for cooking complex dishes, such as a breakfast or similar, where different food items require different heat and cooking time, when placed all at once in the cavity.

**[0028]** As an example, a transparent susceptor element may be provided for food items that can be sufficiently heated by absorbing the HF EMR emitted into the cavity. Further, an absorptive or reflective susceptor element may be provided in order to guide additional heat or HF EMR to the food item or food product placed thereon. Other configurations and operational modes are possible.

**[0029]** In embodiments, a corresponding cooking appliance, specifically a HF EMR source thereof, may be configured for shifting or sweeping the frequency of the HF EMR emitted into the cavity. If, for example, a susceptor element absorbs or reflects in a frequency selective way, the (effective) heating power and heating time applied to the food item(s) placed on that susceptor element may be altered or adapted by adjusting or varying the frequency and/or radiation time of the HF EMR.

**[0030]** As can be seen, great flexibility with regard to purposefully heating food items under different heating or cooking conditions. This may be useful for supporting the user in cooking complex dishes comprising different food items respectively having a different cooking behaviour.

**[0031]** In embodiments, the susceptor arrangement may be configured or adapted for user-configuration, in particular user-modification. This may be obtained by providing the susceptor arrangement, in particular the susceptor elements, in a modular way with regard to mutual arrangement, rearrangement, and replacement. In particular, the susceptor elements may be provided such that a user is enabled to perform at least one of a rearrangement, an addition, a removal, and/or a replacement of one or more susceptor elements. If the user is provided with different susceptor elements, i.e. susceptor elements respectively having different absorption char-

acteristics, the user may configure the 2D heating area in a flexible way. In this regard, the susceptor arrangement, in particular the 2D support area, may comprise or include a surface composed or to be composed of different tiles or patches, where each tile or patch represents or is defined by a susceptor element. In this regard, the susceptor arrangement, in particular 2D support area, may be user-customizable, in particular with regard to the 2D form and/or the absorption characteristic. For example, a user may combine different susceptor elements having different absorption, transmission, or reflection characteristics, i.e. heating or cooking characteristics, to form the 2D support area. By this, the user is enabled to define the overall absorption characteristic, distribution, or pattern of the 2D support area by selecting and placing appropriate susceptor elements to form the 2D support area. Therefore, cooking complex dishes involving different types or kinds of food, respectively requiring different heat treatment, e.g. during cooking, is simplified.

**[0032]** In particular, the cooking accessory may allow for (ex)changing and/or rearranging one or more of the susceptor elements so as to enable changing or adapting the overall absorption/reflection characteristics of the cooking accessory, in particular of the 2D support area. Thus, the user may, dependent on the desired dish to heat or cook, compose the cooking accessory with regard to required heating characteristics and heating distribution for the food items of the dish. For example if the user wishes to heat a food item at a particular location within or with regard to the 2D support area of the cooking accessory, he can position suitable susceptor element(s) in a corresponding location. In particular, the cooking accessory is adapted such that it enables the user to place and mutually arrange the susceptor elements to obtain a desired absorption/reflection/transmission distribution over the 2D support area.

**[0033]** In this respect, the cooking accessory, in particular the 2D support area, may be configured such that the heating characteristic is user customizable or modifiable. User-customization or modification may be related to at least one of the number and mutual arrangement of two or more susceptor elements and the overall 2D shape of the 2D support area. Each susceptor element may have a particular dielectric absorption characteristic, in particular a heating characteristic, and may span a part of the 2D support area. As a note, the absorption characteristic is associated with a heating characteristic. For example, a high absorption coefficient or absorptivity leads to increased EMR power absorption and heat-up rates, in turn associated with the heating characteristic. The same applies to the reflectivity or transmittivity. Thus, the absorption characteristic of the 2D support area may be adapted or modified by applying and inserting susceptor elements having particular absorption characteristics, respectively. For example, the user may use and apply susceptor elements having the same absorption characteristic thereby enabling a 2D support area with unique absorption characteristic. Further, the cooking

accessory may enable the user to apply susceptor elements with different absorption characteristics, such as susceptor elements having a particular absorptivity or reflectivity, so that the 2D support area may be adapted to include different (tiled) sections, each having a specific absorption characteristic.

**[0034]** In embodiments, and as already indicated further above, the HF EMR may comprise at least one of radio frequency and microwave frequency radiation. The radio frequency (RF) may be selected from 1 MHz to 300 MHz, and the microwave frequency (MW) may be selected from 300 MHz to 300 GHz.

**[0035]** In embodiments, the HF EMR may be applied as being or being centered about a single frequency. In other embodiments, the HF EMR may be applied by sweeping the HF EMR over a pre-defined frequency range in the RF and/or MW range, for example. Sweeping or varying the HF EMR may for example be applied in case that the absorption characteristic of the one or more of the susceptor elements is frequency selective. Thus, by sweeping or varying the frequency and applying respective frequencies for pre-defined time periods, different sections of the 2D support area may be heated differently, respectively associated with the particular susceptor elements. This enables a locally selective heating or warming-up of food items, for example while preparing a complex dish, e.g. a breakfast comprising different foodstuff such as eggs, bacon, milk, water etc..

**[0036]** In embodiments, the pre-defined dielectric absorption characteristic of a susceptor element is defined by at least one of the absorptivity, reflectivity, or transmittivity of the susceptor element for the HF EMR used for heating or cooking. The absorptivity, reflectivity, or transmittivity may be defined by the material or material composition used for the susceptor element. The material may be a unique material or a material composition. In embodiments, the susceptor element may comprise a particular material distribution or arrangement of layers having particular absorption characteristics. As an example, a susceptor element may comprise a base layer, for example being substantially transparent to the HF EMR, and a plating or lamination applied to a surface of the susceptor element, the plating or lamination, e.g. a metallic material, may have a high absorption or reflection rate, and may in particular be frequency selective with regard to the HF EMR. In an example, the susceptor element may comprise or be implemented as a plate or plate-like configuration, e.g. made from a metal or metal composition. The plate or plate-like configuration may comprise a plurality of cutouts, e.g. having a cross-shape or any other suitable shape, thereby providing a frequency-selective absorption characteristic.

**[0037]** In embodiments, at least one susceptor element of the susceptor arrangement may comprise a high dielectric absorptivity or reflectivity in the range from 60% to 100%, or a moderate dielectric absorptivity or reflectivity in the range from 30% to 60%, or low dielectric absorptivity or reflectivity in the range from 0% to 30%.

In this regard, the absorption characteristic of the susceptor elements may correspond to an active, semi-active, and inactive susceptor element. By using or selecting such different susceptor elements, the heating characteristic of the 2D support area may be adapted to respective needs with regard to heating or cooking different foodstuff.

**[0038]** In embodiments, the cooking accessory may comprise a supporting base (or: support tray). The supporting base or tray may be substantially transparent for the HF EMR, at least transparent in a particular HF EMR range. The term substantially transparent may be related to an absorptivity of 0% to 30%, preferably of 0% to 15%, further preferably of 0% to 5%. By this, the absorption by the supporting base may be set such that the absorption of the HF EMR by the supporting base or tray may be negligible. This in turn means that the absorption characteristic of the cooking accessory is defined by the susceptor elements as such.

**[0039]** In embodiments, the supporting base may comprise at least one, in particular a plurality, of retainer sections, in particular sockets, each configured for retaining at least one, preferably a single, susceptor element. The retainer section may for example be implemented as a cutout, recess or depression in the supporting base, wherein the depression, recess, or cutout may be configured with regard to size such that a single or several susceptor elements may be inserted into the cutout, recess or depression. The supporting base may therefore provide a kind or frame for inserting susceptor elements.

**[0040]** The supporting base, in particular the retainer sections may be configured such that the susceptor elements may be placed or retained by the supporting base in a user-detachable, in particular a user-removable, user-exchangeable and/or user-interchangeable, way. By this, the user may adapt the absorption characteristic of the 2D support area by inserting respective susceptor elements having a desired absorption characteristic. In particular, in such an embodiment the absorption characteristic of the 2D support area may be considered as user-customizable.

**[0041]** The supporting base may be configured for allowing individual removal and/or replacement of one or more susceptor elements from the supporting base, in particular by a user.

**[0042]** The retainer section and susceptor elements may be configured as having a must-fit configuration in that the inner dimension of the retainer section fits with the outer dimension of the susceptor element or several susceptor elements arranged side-by-side in the retainer section, such as a cutout, depression, or socket. A retainer section may not only be implemented as a contour, but may comprise pins, projections, or other elements that are suitable for holding one or more susceptor elements according to a predefined orientation and (mutual) alignment.

**[0043]** The retainer section may be configured for re-

taining a susceptor element according to least one of a predefined position, a pre-defined (mutual) alignment, and a predefined orientation in the 2D support area.

**[0044]** In embodiments, the supporting base may comprise a plurality of cutouts, depressions, and/or sockets in a tiled arrangement, in particular in matrix-like array. Each depression, cutout, or socket may be configured for accommodating therein at least one susceptor element.

**[0045]** In embodiments, the susceptor elements may be implemented or designed as patches, pads or tiles configured for at least one of a modular and, at least in part, an interchangeable mutual assembly for spanning at least a section of the 2D support area. As an example, such tiles, patches or pads may be configured for fitting into a retainer section, in particular a depression, cutout, or socket, of the cooking accessory, in particular of the supporting base or tray.

**[0046]** In embodiments, the tiles, patches, or pads may have a rectangular shape, with a tile, patch, or pad surface suitable for spanning a section of the 2D support surface. In embodiments, the size of each tile, patch or pad surface may substantially correspond to an integral multiple of a given basic size. As an example, each of the tiles, patches or pads may have the same size. In alternatives, the tiles, patches, or pads may be shaped such that the ratio of their area size spanned in parallel the 2D support area is a positive integer.

**[0047]** In embodiments, at least some of the susceptor elements may comprise interlocking elements configured for establishing a mechanical interconnection with one or more complementary interlocking elements of one or more other susceptor elements and/or interlocking elements provided at a or the retainer section.

**[0048]** In embodiments, the interlocking elements may be provided at at least one peripheral section, in particular circumferential edge or side, of the susceptor element. The interlocking elements may comprise interlocking notches and bulges, such as jigsaw-puzzle type interlocking elements, for example.

**[0049]** In embodiments, at least one susceptor element may comprise at least one material or a combination of materials selected from the group comprising: ceramic, glass-ceramic, borosilicate glass, metal. The material may be selected according to the desired absorption requirements. For example, ceramic may have a comparatively high absorptivity. Glass-ceramic may have a moderate absorptivity. Borosilicate glass may be substantially transparent. Metal may have a high reflectivity. The mentioned properties may be dependent on the frequency of the HF EMR used or applied for heating or cooking.

**[0050]** Similar, the supporting base may be manufactured from one of these materials. In particular, the supporting base may be made of a transparent material, i.e. a material that is substantially transparent to the HF EMR, e.g. borosilicate glass or similar.

**[0051]** In embodiments, at least one susceptor ele-

ment may comprise a resonant dielectric topology, in particular at least one of a resonant dielectric 2D structure, such as a frequency selective surface, or a resonant dielectric 3D structure, such as a frequency selective grid. The grid may for example comprise a regular arrangement of susceptor sections respectively contributing to the overall absorption characteristic.

**[0052]** In embodiments, the resonant dielectric 2D or 3D structure may comprise at least one reflective section made of a reflective material, in particular metal, that is reflective for the HF EMR. The 2D or 3D structure may comprise at least one transparent section made of a transparent material that is substantially transparent for the HF EMR. The reflective section may be provided as a surface layered structure, such as a lamina, on one or more transparent tiles, in particular a base material. In embodiments, transparent section may be provided as or in connection with one or more cutouts in one or more reflective tiles or base materials. The tiles or base materials may be arranged on a substantially transparent substrate. In embodiments, the resonant dielectric 2D or 3D structure may comprise a composite structure including one or more reflective materials and/or one or more transparent materials, wherein at least one of the materials is provided in the form of a 2D or 3D grid or mesh. At least one of the materials may be provided as a filler for filling gaps provided in gaps of the 2D or 3D grid or structure.

**[0053]** In embodiments, the resonant dielectric 2D or 3D structure may comprise a plurality of reflective and/or transparent sections.

**[0054]** The reflective and/or transparent sections may be provided in a regular pattern. In particular, the sections may be provided in a matrix-pattern. In embodiments, the reflective and/or transparent sections, or absorptive sections, of a susceptor element may have the same 2D or 3D shape. As an example, the shape may be cross-shaped, include a regular arrangement of holes, circular holes or other geometric shapes. The structure may be provided as lamina and/or cutouts.

**[0055]** In embodiments according to the invention, a dielectric cooking appliance is provided. The appliance comprises a cavity and one or more heating elements for dielectrically heating one or more food items or object placed within the cavity by irradiating the cavity with HF EMR. The EMR preferably comprises a radio frequency and/or microwave frequency radiation. The appliance comprises a cooking accessory according to one of the embodiments described herein in connection with the invention. The cooking accessory is preferably configured for removable placement within the cavity for supporting at least one food item, object, or product thereon while being irradiated with the HF EMR.

**[0056]** In embodiments according to the invention, a kit of parts is provided. The kit of parts comprises a plurality of susceptor elements, in particular susceptor elements described in connection with the present invention. Each susceptor element may have a selected pre-defined di-

electric absorption characteristic for HF EMR in the radio frequency and/or microwave frequency range suitable for heating or cooking food. In connection with the kit of parts, the susceptor elements may be configured for assembling a susceptor arrangement of a cooking accessory according to one of the embodiments described in connection with one of the embodiments of the invention herein. In the kit of parts, the susceptor elements are configured such that, when assembled, the susceptor elements span the tiled 2D support area. The kit of parts may comprise more susceptor elements than is necessary for setting together a cooking accessory suitable for placement in a standard-sized cavity. The kit of parts may comprise several groups of one or more susceptor elements, each group being associated with a pre-defined absorptivity, reflectivity, or transmittivity.

**[0057]** In particular, the invention is directed to a use of corresponding tiles, patches or pads and elements, in particular susceptor elements, for making up or assembling a tiled 2D support area. The susceptor elements may be configured such that susceptor arrangements of different size may be assembled, or such that a susceptor arrangement with a standard 2D size comprising a pre-defined possible number of susceptor elements may be assembled. The standard size may be adapted to standard sizes and dimensions of conventional HF EMR cooking cavities. Each tile, patch or pad, in particular susceptor element, may be configured for use to span a section of the 2D heating surface, where the user may place the tiles, patches or pads in a user-specific manner and/or orientation.

**[0058]** In particular, the invention may be directed to a combination comprising a cooking accessory according to an embodiment of the invention described herein. The combination may comprise a plurality of susceptor elements, where each susceptor element may have a selected pre-defined dielectric absorption characteristic for the HF EMR in the radio frequency and/or microwave frequency range. The susceptor elements may be configured for use as a tile, patch, or pad suitable for forming a part or section of the tiled 2D support area, wherein the 2D support area spans a section of the areal heating surface. The susceptor elements may be configured for user-specific placement and/or orientation within the heating surface to form the 2D support area.

**[0059]** In embodiments, in particular related to the kit of parts, each susceptor element may comprise an identifier indicating a pre-defined dielectric absorption characteristic. The identifier may be representative for a pre-defined absorption characteristic. The identifier may comprise at least one of a color, a color code, a user or computer readable ID, a number, a text etc., representative for the pre-defined absorption characteristic of the susceptor element.

**[0060]** In the following, exemplary embodiments and exemplary aspects of the underlying invention will be described in connection with the annexed figures, in which:

- FIG. 1 shows an exemplary cooking accessory of a first embodiment;
- FIG. 2 shows a further embodiment of a cooking accessory;
- FIG. 3 shows different susceptor elements;
- FIG. 4 shows exemplary arrangements of susceptor elements;
- FIG. 5, 6 show exemplary embodiments of different susceptor elements having frequency-selective absorption characteristics;
- FIG. 7, 8 show exemplary arrangements of susceptor elements described in connection with FIG. 5 and FIG. 6;
- FIG. 9 shows a further exemplary embodiment of a cooking accessory;
- FIG. 10 shows a yet further exemplary embodiment of a cooking accessory; and
- FIG. 11 shows a dielectric cooking appliance.

**[0061]** FIG. 1 shows an exemplary cooking accessory 1 of a first embodiment. The cooking accessory 1 comprises in the present embodiment a supporting base 2, e.g. a tray. On the supporting base 2 there are arranged several susceptor elements 3. The susceptor elements 3 are placed on the supporting base 2 in a regular manner, in particular in a matrix-like arrangement having in the present case two rows and three columns. It shall be noted that the number and arrangement of the susceptor elements 3 may be different, and that the arrangement and number in FIG. 1 is merely illustrative. This applies also for the arrangement and numbers of susceptor elements of the embodiments shown and described in connection with the other figures.

**[0062]** The cooking accessory 1 is configured for HF EMR heating or cooking, wherein the cooking accessory 1 is dimensioned, sized, and configured such that it can be placed in a heating or cooking cavity of an appliance, e.g. a household appliance, which is configured for heating or cooking food by HF EMR.

**[0063]** The cooking accessory 1 is configured for supporting food items (not shown), wherein the food items may be placed on the susceptor elements 2 while being heated or cooked with HF EMR.

**[0064]** The susceptor elements 3 are provided in accordance with a particular susceptor arrangement, as mentioned a matrix-like arrangement. In this arrangement, the susceptor elements 3 span a tiled 2D support area as can be seen from FIG. 1. The 2D support area is for supporting the food items during heating or cooking, and is spanned by the upper surfaces of the susceptor

elements 3 positioned in the ordinary use orientation.

**[0065]** Each susceptor element 3 has a pre-defined dielectric absorption characteristic for the HF EMR. The HF EMR may be provided with a fixed frequency, or may be applied in a frequency sweep manner, in which the frequency of the HF EMR is swept or varied (in time) over a range of frequencies.

**[0066]** In particular, each susceptor element 3 may have a specific absorptivity, transmittivity, or reflectivity for the HF EMR. In the exemplary embodiment according to FIG. 1, there are three groups of susceptor elements 3, wherein the susceptor elements 3 in each group have the same absorption characteristic, and in which the susceptor elements 3 of different groups have different absorption characteristics.

**[0067]** In FIG. 1, a first group A of susceptor elements 3 has a high absorptivity, e.g. in the range from 60% to 100%. A second group B of susceptor elements 3 has a moderate to low absorptivity, e.g. in the range from 30% to 60%. A third group C of susceptor elements 3 is substantially transparent for the HF EMR.

**[0068]** The HF EMR may be EMR in the radio frequency range, e.g. from 1MHz to 300 MHz, or in the microwave frequency range, e.g. from 300 MHz to 300 GHz. The absorption characteristic of the susceptor elements 3 may be adapted for respective frequency ranges.

**[0069]** In the example of FIG. 1, the first group A of susceptor elements absorbs HF EMR to a substantial amount and thereby heats up. By this, the heating or cooking of a food item placed on these susceptor elements 3 is supported by the heat generated in the group A susceptor elements 3. In particular, the food item may, in addition to the absorption of the HF EMR in the food item as such, be heated from below by the susceptor element 3 to support heating or cooking. For example if the food item is pizza, the dough at the lower side, which may be less absorptive, may be heated by means of the heat generated by the group A susceptor elements 3.

**[0070]** The second group B of susceptor elements 3 absorbs HF EMR only to a moderate amount, meaning that the heating or cooking support provided by the heat absorbed in these susceptor elements 3 is lower. Group B susceptor elements 3 may be applied if heating or cooking support from below is required, but to a lower amount.

**[0071]** The third group C of susceptor elements 3 is substantially transparent to HF EMR. Such susceptor elements 3 may be provided if the food item as such shows sufficient absorptivity, e.g. with regard to uniform heating.

**[0072]** With the group A and group B susceptor elements 3, not only additional heat may be provided, but also a more uniform heating may be obtained.

**[0073]** FIG. 2 shows a further embodiment of a cooking accessory 1, where the susceptor arrangement of susceptor elements 3 is configured for user-configuration and modification. Whereas the susceptor elements 3 in the embodiment of FIG. 1 may be fixedly arranged on the

supporting base 2 (but of course need not), the susceptor elements 3 of the embodiment in FIG. 2 may be removed and rearranged on the supporting base 2 to form a 2D support area including susceptor elements 3 as needed.

5 In particular, the susceptor elements 3 are configured to enable at least one of a rearrangement, an addition, a removal, and/or a re-placement of one or more susceptor elements 3 by a user.

**[0074]** In FIG. 2, the susceptor elements 3 are illustrated in a position next to the supporting base 2, wherein dashed arrows indicate that the user may place these susceptor elements 3 on the supporting base 2 as required, where only some exemplary permutations and rearrangements are depicted by the arrows. The susceptor elements 3 are configured such that they can be freely placed on the supporting base 2.

**[0075]** The supporting base 2 is made from a material that is substantially transparent for the applied HF EMR. The function of the supporting base 2 is to hold the susceptor elements 3 such that they may be inserted into the cavity of the appliance all at once, in particular with the food items placed or placeable on the susceptor elements 3 respectively desired for heating or cooking. The supporting base 2 may for example have a size to fit into a cooking cavity having a standardized size.

**[0076]** FIG. 2 depicts merely six susceptor elements 3 of three different absorption groups. However, the cooking accessory may have or may be assembled with a different number of susceptor elements 3 in each group, in particular with regard to absorptivity, transmittivity, or reflectivity. Further, the number of groups may be different.

**[0077]** By this, the absorption characteristic of the tiled 2D support area, which in the end is defined by the susceptor elements 3, is modular and can be freely defined by the user within the possibilities given by the available susceptor elements 3 and the size of the supporting base 2.

**[0078]** In this connection, the supporting base 2 and the multiple of susceptor elements 3 may be considered as representing a kit of parts.

**[0079]** FIG. 3 exemplarily depicts that the dimensions of the susceptor elements 3 may be the same, while the absorptivity, transmittivity, or reflectivity of the susceptor elements 3 may be different. Depending on the material of the susceptor element 3, e.g. ceramic, glass-ceramic, borosilicate glass, or metal, or a combination thereof, the absorption characteristic, i.e. absorptivity, transmittivity, or reflectivity may be different.

50 **[0080]** FIG. 3, shows four different susceptor elements with a first one belonging to group A, e.g. made from ceramic, a second one belonging to group B, e.g. made from glass-ceramic, a third one belonging to group C, e.g. made from borosilicate glass, and a fourth one belonging to a fourth group D, having a particular reflectivity and being made for example, at least in part, from metal. These susceptor elements 3 are configured for placement on the supporting base 2. However, the susceptor

elements 3 may be placed or configured for placement within the cavity without the supporting base 2.

**[0081]** The susceptor elements 3 in FIG. 1 to 3 all have the same size. However, it is also possible that the size of the susceptor elements 3 varies, e.g. such that the dimensions of the susceptor elements 3, in particular with regard to the upper surface area thereof, is an integral multiple of a given basic size. The basic size may for example correspond to the size as shown in FIG. 3, or may be half the size of the susceptor elements 3, or may be twice the size etc..

**[0082]** By this, the user may configure the 2D support area in a granular manner according to respective needs for heating or cooking.

**[0083]** FIG. 4 shows exemplary arrangements of susceptor elements 3 on the supporting base 2, respectively involving different combinations and mutual arrangements of susceptor elements 3 selected from groups A to D. This again shows that the cooking accessory 1 as suggested herein allows great flexibility with regard to HF EMR heating and cooking, which is of advantage for cooking complex meals involving different types and kinds of food, e.g. a breakfast or others.

**[0084]** FIG. 5 and FIG. 6 show exemplary embodiments of different susceptor elements 3 having a frequency-selective absorption characteristic.

**[0085]** In FIG. 5, a susceptor element 3, shown on the left-hand side, is provided that is substantially transparent in a particular frequency range, while being reflective outside of this range. The absorption characteristic of the susceptor element 3 is illustrated in the diagram shown at the right-hand side, where the reflectivity R is shown in dependence of the frequency of the HF EMR. Specifically, the reflectivity-frequency curve R(f) of the susceptor element 3 has a window W1 where the reflectivity R has a minimum, whereas the reflectivity R outside of this window has a particular, high level of reflectivity R. In the frequency range f1, corresponding to this window W1, the susceptor element 3 is this substantially transparent for the HF EMR. In the frequency ranges to the left and right side of the frequency range f1, the susceptor element 3 shows high reflectivity R, with a maximum reflectivity R being provided in windows W2 and W3. The susceptor element 3 having a corresponding absorption characteristic with a reflectivity R varying according to the shown graph in FIG. 5 may for example be made from metal with cutouts 4, in the present case four cutouts 4 having a cross-shape, and being provided in a regular, matrix-like pattern. As a note, the shape of the cutouts 4 is only illustrative and may be different, e.g. circular, oval, rectangular etc..

**[0086]** By providing such a susceptor element 3 with a frequency dependent reflectivity R as shown in FIG. 5, the amount of HF EMR being reflected by the susceptor element 3 and finally absorbed by a food product placed on the susceptor element 3 may be varied by varying the frequency f of the HF EMR emitted into the cavity. By sweeping the frequency f, heating or cooking may be

adapted and varied according to respective needs. For example, by operating a HF EMR source or sources of the appliance in the window W1, normal absorption of the food product may contribute to heating or cooking. If the frequency f is shifted outside of the window W1, heating may be enhanced. Depending on the time period in which the HF EMR source remains in the windows W1 to W3, heating or cooking may be adapted. By this, cooking programs requiring varying heating may be conducted, for example.

**[0087]** In other embodiments, for example if different types of such susceptor elements 3 are used, for example according to groups A to C or other, locally selective heating may be provided, which is in turn advantageous for cooking complex dishes. As a note, by sweeping the frequency f the locally selective heating may be influenced depending on how fast the sweep occurs and on how long the HF EMR source is kept to emit in a particular one of the windows W1 to W3.

**[0088]** The cutouts 4 may be implemented as openings or may be filled, for example, with a material that is substantially transparent to HF EMR.

**[0089]** In FIG. 6, a susceptor element 3, shown at the left-hand side, is provided that has a high reflectivity R in a particular frequency range, while being substantially transparent outside of this range. The absorption characteristic of the susceptor element 3 is illustrated in the diagram shown in FIG. 6 at the right-hand side, where the reflectivity R is shown in dependence of the frequency f of the HF EMR. Specifically, the reflectivity-frequency curve R(f) of the susceptor element 3 has a window W4 where the reflectivity R has a maximum, whereas the reflectivity R outside of this window W4 is low. In the frequency range f2, corresponding to this window W4, the susceptor element 3 reflects a substantial amount of the HF EMR. In the frequency ranges according to windows W5 and W6 arranged to the left and right side of the frequency range f1 and window W4, the susceptor element 3 has a low reflectivity R and is substantially transparent for the HF EMR in these frequency ranges. The susceptor element 3 having a corresponding absorption characteristic with a reflectivity R varying according to the graph shown in FIG. 6 may for example comprise a substrate 5 that is substantially transparent for the HF EMR, with metallic elements 6, in the exemplary embodiment having a cross-shape, being laminated on the substrate, for example. In the present case, four metallic elements 6 are provided in a regular, matrix-like pattern. As a note, the shape of the metallic elements 6 is only illustrative and may be different, e.g. circular, rectangular etc..

**[0090]** By providing such a susceptor element 3 with a frequency dependent reflectivity as shown in FIG. 6, the amount of HF EMR being reflected by the susceptor element 3 and finally absorbed by a food product placed on the susceptor element 3 may be varied by varying the frequency f of the HF EMR emitted into the cavity. By sweeping the frequency f, heating or cooking may be adapted and varied according to respective needs. For

example, by operating the HF EMR source or sources of the appliance in the windows W5 and W6, normal absorption of the food product may contribute to heating or cooking. If the frequency  $f$  is shifted into window W4, heating may be enhanced by the increased reflectance R. Depending on the time period in which the HF EMR source remains in either of the windows, heating or cooking may be adapted. By this, cooking programs requiring varying heating may be conducted, for example. In other embodiments, for example if different types of such susceptor elements 3 are used, for example as described as beforehand (groups A to C or other), locally selective heating may be provided, which in turn is advantageous for cooking complex dishes. As a note, by sweeping the frequency  $f$  the locally selective heating may be influenced depending on how fast the sweep occurs, and on how long the HF EMR source remains in a particular one of the windows.

**[0091]** In addition, if the susceptor elements 3 as described in connection with FIG. 5 and FIG. 6 are used simultaneously, locally selective heating may be provided in that the susceptor element 3 of FIG. 5 is substantially transparent in frequency ranges where the susceptor element 3 of FIG. 6 has high reflectivity, and vice versa.

**[0092]** FIG. 7 and FIG. 8 show exemplary arrangements of susceptor elements 3 described in connection with FIG. 5 and FIG. 6 on a supporting base 2 together with diagrams showing frequency-dependent reflectivity curves  $R(f)$  associated with the susceptor arrangement.

**[0093]** In FIG. 7 susceptor elements 3 as described in connection with FIG. 5 are arranged on the supporting base, wherein the susceptor elements 3 differ from each other in the number and size of cutouts 4. The susceptor elements 3 are positioned on the supporting base 2 in a matrix-like arrangement, where each column includes the same type of susceptor element 3, whereas the susceptor element type varies between the columns.

**[0094]** By providing different numbers and sizes of cutouts, the  $R(f)$  curves of the susceptor elements 3, illustrated by different line-types, have different minima in the reflectivity R. For example, the susceptor elements 3 of the left column have a minimum reflectivity R at a first frequency  $f_{M1}$ , which is lower than the second frequency  $f_{M2}$  of the minimum reflectivity R of the susceptor elements 3 of the middle column, which is lower than the third frequency  $f_{M3}$  of the minimum reflectivity R of the susceptor elements 3 of the right column. By this, sweeping the HF EMR over the frequency range including the first to third frequencies  $f_{M1}$  to  $f_{M3}$ , locally selective heating and cooking can be provided for food items located in a particular column (left, middle, right) of the 2D support area spanned by the susceptor elements 3. Further, the speed of change and/or the length of stay in a particular frequency range may affect the heating or cooking in that different zones (left, middle, or right column) may purposefully be heated according to respective needs.

**[0095]** FIG. 8 shows a further illustrative embodiment

with different susceptor elements 3 described in connection with FIG. 5 and FIG. 6 being arranged on the supporting base 2. In the susceptor arrangement of FIG. 8, the left and right column of susceptor elements 3 include susceptor elements 3 described and shown in connection with FIG. 5. The middle column comprises susceptor elements 3 shown and described in connection with FIG. 6.

**[0096]** As may be seen from the  $R(f)$  curves shown in FIG. 8, the susceptor elements 3 of the right and left column have a minimum reflectivity R at frequency  $f_{M4}$  (dashed  $R(f)$  curve), while the susceptor elements 3 of the middle column have a maximum reflectivity R at this frequency  $f_{M4}$  (dash-dotted  $R(f)$  curve). By this arrangement, supplying HF EMR in the region of the frequency  $f_{M4}$ , the susceptor elements 3 of the left and right column are substantially transparent, while the susceptor element 3 of the middle columns has a high reflectivity R. On the other hand, if HF EMR is supplied outside of the frequency region comprising the frequency  $f_{M1}$ , the susceptor elements 3 of the middle column are substantially transparent, while the susceptor elements 3 of the right and left column show high reflectivity R. Again, by selecting and applying a suitable frequency  $f$ , in particular by frequency sweeping, the different zones, i.e. columns, of the 2D support area spanned by the susceptor elements 3 may be heated differently. In the particular embodiment, the reflectivity R of the left and right column on the one hand, and the reflectivity R of the middle column on the other hand are opposed to each other, thereby enabling locally selective heating or cooking, in particular with regard to the amount of HF EMR subjected to the food items placed in these regions.

**[0097]** It is noted that FIG. 7 and 8 represent exemplary embodiments showing that the cooking accessory as suggested herein is suitable and effective for locally selective heating or cooking. Further, these exemplary embodiments show that the user has great flexibility in adapting the absorption characteristic, in particular absorptivity, transmittivity, or reflectivity, of the 2D support area spanned by the susceptor elements 3.

**[0098]** FIG. 9 shows a further exemplary embodiment of a cooking accessory 1. In this embodiment, the susceptor elements 3 comprise interlocking elements 7 configured for establishing a mechanical interconnection with one or more complementary interlocking elements 7 of one or more other susceptor elements 3. The interlocking elements 7 are, in the given example, provided at at least one peripheral section of the susceptor element 3. Further, the interlocking elements 7 are implemented as notches 8 and bulges 9, such as jigsaw-puzzle type interlocking elements. The susceptor elements 3 shown in FIG. 9 may be implemented with regard to the absorption characteristic in accordance with one of the embodiments described above.

**[0099]** In the present example, the susceptor elements 3 may be interconnected by the interlocking elements 7 to form an interconnected susceptor arrangement of sus-

ceptor elements 3 mutually fixed to each other to provide a combination of susceptor elements 3 that is handleable as a single piece. The interconnection elements 7 enable a user to modify the types of susceptor elements 3 used, and also enable a user to modify the overall size and particular configuration of the susceptor arrangement. In particular, such interlocking elements 7 provide great flexibility for the user to set up the cooking accessory 1 in a modular way.

**[0100]** FIG. 10 shows a yet further exemplary embodiment of a cooking accessory 1. The cooking accessory 1 of FIG. 10 resembles the one shown in FIG. 1 and 2. In the embodiment of FIG. 10, the supporting base 2 comprises a plurality of retainer sections 10, in particular sockets in the form of recesses, provided in the supporting base 2. Each retainer section 10 is configured for accommodating and retaining a susceptor element 3 in a user-detachable, user-removable, user-exchangeable, and/or user-interchangeable, way. The retainer section 10 as shown is configured for retaining the susceptor elements 3 in a matrix-like pattern with a predefined position, a predefined alignment, and a predefined orientation. The susceptor elements 3 shown in FIG. 10 correspond to those described in connection with FIG. 5 and FIG. 6, which shall only be illustrative. Other susceptor elements, for example selected from any of groups A to D may be provided and used. The retainer sections 10 are advantageous for supporting the user in placing the susceptor elements 3 in the cavity according to a preferred arrangement. Locally selective heating is possible in a similar way as described further above by using different kind and combinations of susceptor elements 3.

**[0101]** In the examples described above, the susceptor elements 3 are implemented as patches, pads or tiles that are configured for at least one of a modular and, at least in part, an interchangeable mutual assembly for spanning at least a section of the 2D support area provided by the cooking accessory 1 for supporting food products or food items thereon for being heated in the cavity.

**[0102]** In the examples, the susceptor elements 3, e.g. tiles, patches or pads, have a rectangular shape, with an upper surface spanning a section of the 2D support surface. The size of the susceptor elements 3 in the given examples is the same. However, the shape and size may be different. In particular, the size of the surfaces ay correspond to an integral multiple of a given basic size.

**[0103]** The material of the supporting base 2 is preferably substantially transparent for the HF EMR, and the materials of the susceptor elements 3 is preferably selected as described further above. Suitable materials are for example, in descending order of absorptivity: ceramic, glass-ceramic, borosilicate glass, metal.

**[0104]** A susceptor element 3 may comprise a resonant dielectric topology, such as for example described in connection with FIG. 5 and FIG. 6, in particular at least one of a resonant dielectric 2D structure, such as a frequency selective surface (FIG. 6), or a resonant dielectric 3D structure, such as a frequency selective grid

(FIG. 6).

**[0105]** It shall be noted that the exemplary embodiments described in connection with the reflectivity R and the explanations given in connection with these embodiments, in particular in connection with the susceptor elements 3, apply mutatis mutandis for the absorptivity. In particular, the absorption characteristic, in particular a frequency-dependent absorption characteristic, may relate to the absorptivity of reflectivity depending on the material used. For example, a susceptor element 3 made from a ceramic material may have a comparatively high absorptivity and may therefore be described based on the absorptivity, whereas a susceptor element made from metal or comprising metal elements or metal components may be described based on the reflectivity rather than absorptivity (see examples given above).

**[0106]** FIG. 10 shows a dielectric cooking appliance 11 comprising a cavity 12 and one or more HF EMR heating elements 13, such as antennas and others, for dielectrically heating a food object (not shown) placed within the cavity 12 by irradiating the cavity 12 with HF EMR, such as radio frequency or microwave frequency radiation. A cooking accessory 1 is placed in the cavity 12. The cooking accessory 1 is designed according to the cooking accessories 1 described further above including a supporting base 2 (which may also be omitted) with a plurality of susceptor elements 3, which may be implemented as described in the embodiments above. The cooking accessory 1 is dimensioned for placement within the cavity 12 for supporting at least one food product thereon while being irradiated with the HF EMR.

**[0107]** The appliance 11 may comprise a control unit 14 that is configured for operating the HF EMR heating elements 13 with a fixed frequency or a variably frequency, e.g. by sweeping or switching between frequencies. By this, locally selective heating may be provided according to the absorption characteristic of the susceptor elements 3, the susceptor elements 3 spanning the 2D support area for accommodating one of more food items, and selected and purposively placed on the supporting base 2 by a user to obtain a particular absorption characteristic. The placement and mutual arrangement, as well as the information for a user which susceptor element 3 he may use, may be provided to the user in a user manual and/or in a recipe for cooking food (items) or a dish.

**[0108]** The embodiments and exemplary examples described above show that the suggested cooking accessory is suitable for solving the underlying problem. In particular, the cooking accessory is suitable for supporting the user in cooking food, in particular in connection with complex dishes, requiring, as the case may be, respectively different heating or cooking conditions. By providing the user with the possibility to combine the susceptor elements 3 in a flexible and modular way, the user is provided with a solution for locally selective heating, which he may implement in a comparatively simple manner, without requiring in depth knowledge

of HF EMR.

**[0109]** The cooking accessory 1 as described above may be provided as a kit of parts comprising a plurality of susceptor elements 3, each susceptor element 3 having a selected pre-defined dielectric absorption characteristic for HF EMR in the radio frequency and/or microwave frequency range suitable for cooking food. The susceptor elements 3 in this kit of parts are configured for assembling a susceptor arrangement and 2D support area according to a cooking accessory as described above, in which the assembled susceptor elements 3 span the tiled 2D support area for supporting food items thereon while being irradiated with the HF EMR.

**[0110]** In order to facilitate the assembly of a susceptor assembly that is suitable for a particular use case, each susceptor element 3 of a particular group (e.g. A to D), class or type may comprise or provided with an identifier, such as a specific color, color code, an user or computer-readable ID, a number, plain text or similar, indicating a pre-defined dielectric absorption characteristic of the susceptor element 3.

**[0111]** If the appliance 11 comprises, for example, a functionality, in particular in connection with a sweep functionality, for determining the reflectivity and/or absorptivity and/or transmittivity of items placed within the cavity 12, the appliance 11 may be configured for determining the absorption characteristic of the cooking accessory 1 placed within the cavity 12, such as a local absorption profile, for example when the cooking accessory is placed within the cavity without other items, such as food items, and a corresponding function is started or activated.

**[0112]** Further, if the appliance 11 comprises or is associated with a display device, the appliance 11 may be configured for displaying the absorption characteristic, in particular the local distribution of the absorption characteristic, of the cooking accessory 1 placed in the cavity 12. By this, the appliance 11 may provide support to the user for example with regard to correct assembly and arrangement of the susceptor elements 3.

**[0113]** Further, the appliance may be configured for providing a list of food items that may be placed in a particular location within the cavity 12 based on the determined absorption characteristic. This may support the user when he is about to cook a complex meal involving different types of food respectively requiring different heating or cooking.

**[0114]** In embodiments, the appliance may suggest distribution or arrangement of susceptor elements 3 that is suitable for heating or cooking food items of for example a dish, based e.g. on a recipe stored on the appliance. By this further user support for heating or cooking food items or complex dishes may be provided.

#### List of reference numerals

**[0115]**

1	cooking accessory	
2	supporting base	
3	susceptor element	
4	cutout	
5	5	substrate
6	metallic element	
7	interlocking element	
8	notch	
9	bulge	
10	10	retainer section
11	dielectric cooking appliance	
12	cavity	
13	heating element	
14	control unit	
15	A	first group of susceptor elements
	B	second group of susceptor elements
	C	third group of susceptor elements
	D	fourth group of susceptor elements
20	R	reflectivity
	f	frequency
	$f_M$	frequency of minimum or maximum reflectivity
	W	windows

#### 25 Claims

1. A cooking accessory (1) for high-frequency dielectric heating, configured for placement in a dielectric heating cavity (12) of a cooking appliance (11) and suitable for supporting one or more food items thereon while being irradiated with high-frequency electromagnetic radiation for heating the one or more food items in the heating cavity (12), the cooking accessory (1) comprising susceptor arrangement (2-3; 3) with susceptor elements (3), each susceptor element (3) having a pre-defined dielectric absorption characteristic (R) for the high-frequency electromagnetic radiation, **characterised in that** the susceptor elements are arranged to span a tiled 2D support area for the one or more food items.
2. The cooking accessory (1) according to claim 1, the susceptor arrangement (2-3; 3) being adapted for user-configuration and modification enabling least one of a rearrangement, an addition, a removal and/or a replacement of one or more susceptor elements (3) by a user.
3. The cooking accessory (1) according to claim 1 or 2, the high-frequency electromagnetic radiation comprising at least one of radio frequency and microwave frequency radiation, the radio frequency preferably selected from 1 MHz to 300 MHz, and the microwave frequency preferably selected from 300 MHz to 300 GHz.
4. The cooking accessory (1) according to any of claims 1 to 3, the pre-defined dielectric absorption charac-

- teristic of a susceptor element (3) being defined by at least one of the absorptivity, reflectivity (R), or transmittivity of the susceptor element (3) for the high-frequency electromagnetic radiation used for heating.
- 5
- 10
- 15
- 20
- 25
- 30
- 35
- 40
- 45
- 50
- 55
- (8, 9) of one or more other susceptor elements (3) and/or interlocking elements (8,9) provided at or in the retainer section (10), wherein the interlocking elements (8, 9) are preferably provided at at least one peripheral section of the susceptor element (3), and optionally comprise interlocking notches (8) and bulges (9), such as jigsaw-puzzle type interlocking elements.
11. The cooking accessory (1) according to any of claims 1 to 10, at least one susceptor element (3) comprising at least one material or a combination of materials selected from the group comprising: ceramic, glass-ceramic, borosilicate glass, metal.
12. The cooking accessory (1) according to any of claim 1 to 11, at least one susceptor element (3) comprising a resonant dielectric topology, in particular at least one of a resonant dielectric 2D structure, such as a frequency selective surface, or a resonant dielectric 3D structure, such as a frequency selective grid.
13. The cooking accessory (1) according to claim 12, the resonant dielectric 2D or 3D structure comprising at least one reflective section made from a reflective material, in particular metal, that is reflective for the high-frequency electromagnetic radiation, and/or at least one transparent section (4, 5) made from a transparent material that is substantially transparent for the high-frequency electromagnetic radiation, wherein the reflective section (6) is provided as a surface layered structure, such as a lamina, on one or more transparent tiles, or wherein the transparent section is provided as or in connection with one or more cutouts (4) in one or more reflective tiles, the tiles optionally being arranged on a substantially transparent substrate.
14. The cooking accessory (1) according to claim 12 or 13, the resonant dielectric 2D or 3D structure comprising a plurality of reflective and/or transparent sections, wherein the reflective and/or transparent sections are provided in a regular pattern, in particular a matrix-pattern, the reflective and/or transparent sections of a susceptor element (3) preferably having the same 2D or 3D shape.
15. Dielectric cooking appliance (11) comprising a cavity (12) and one or more heating elements (13) for dielectrically heating one or more food item placed within the cavity (12) by irradiating the cavity (12) with high-frequency electromagnetic radiation, such as radio frequency or microwave frequency radiation, and a cooking accessory (1) according to at least one of claims 1 to 14 preferably configured for removable placement within the cavity (12) for supporting at least one food item thereon while being irradiated
1. The cooking accessory (1) according to claim 4, wherein at least one susceptor element (3) of the susceptor arrangement (2-3; 3) comprises a high dielectric absorptivity or reflectivity (R) in the range from 60% to 100%, or a moderate dielectric absorptivity or reflectivity (R) in the range from 30% to 60%, or low dielectric absorptivity or reflectivity (R) in the range from 0% to 30%.
2. The cooking accessory (1) according to any of claims 1 to 5 comprising a supporting base (2) that is, preferably, substantially transparent for the high-frequency electromagnetic radiation, the supporting base (2) optionally comprising at least one, in particular a plurality, of retainer sections (10), in particular sockets, each configured for retaining at least one, preferably a single, susceptor element (3) in a user-detachable, in particular a user-removable, user-exchangeable and/or user-interchangeable, way, the retainer section (10) preferably configured for retaining a susceptor element (3) according to least one of a predefined position, a pre-defined alignment and a pre-defined orientation with regard to the 2D support area.
3. The cooking accessory (1) according to claim 6, the supporting base (2) comprising a plurality of depressions (10) and/or sockets in a tiled arrangement, in particular in matrix-like array, each depression (10) or socket configured for accommodating therein at least one susceptor element (3).
4. The cooking accessory (1) according to any of claims 1 to 7, wherein the susceptor elements (3) are implemented as patches, pads or tiles configured for at least one of a modular and, at least in part, an interchangeable mutual assembly for spanning at least a section of the 2D support area.
5. The cooking accessory (1) according to claim 8, wherein the tiles, patches or pads have a rectangular shape, with a tile, patch or pad surface suitable for spanning a section of the 2D support surface, wherein, preferably, the size of each tile, patch or pad surface substantially corresponds to an integral multiple of a given basic size.
6. The cooking accessory (1) according to any of claims 1 to 9, at least some of the susceptor elements (3) comprising interlocking elements (8, 9) configured for establishing a mechanical interconnection with one or more complementary interlocking elements

with the high-frequency electromagnetic radiation.

16. A kit of parts (2-3; 3) comprising a plurality of susceptor elements (3), each susceptor element (3) having a selected pre-defined dielectric absorption characteristic (R) for high-frequency electromagnetic radiation in the radio frequency and/or microwave frequency range suitable for heating or cooking food, wherein the susceptor elements (3) are configured for assembling a susceptor arrangement (2-3, 3) of a cooking accessory (1) according to any of claims 1 to 14 in which the assembled susceptor elements (3) span the tiled 2D support area.
17. The kit of parts (2-3; 3) of claim 16, each susceptor element (3) comprising an identifier indicating a pre-defined dielectric absorption characteristic (R).

### Patentansprüche

1. Garzubehör (1) zum hochfrequenten dielektrischen Erwärmen, das zum Platzieren in einem dielektrischen Heizhohlraum (12) eines Gargeräts (11) konfiguriert ist und zum Tragen eines oder mehrerer Lebensmittelartikel darauf geeignet ist, während es mit hochfrequenter elektromagnetischer Strahlung zum Erwärmen des einen oder der mehreren Lebensmittelartikel in dem Heizhohlraum (12) bestrahlt wird, wobei das Garzubehör (1) eine Suszeptoranordnung (2-3; 3) mit Suszeptorelementen (3) umfasst, wobei jedes Suszeptorelement (3) eine vordefinierte dielektrische Absorptionscharakteristik (R) für die hochfrequente elektromagnetische Strahlung aufweist, **dadurch gekennzeichnet, dass** die Suszeptorelemente so angeordnet sind, dass sie einen 2D-Trägerkachelbereich für das eine oder die mehreren Lebensmittel überspannen.
2. Garzubehör (1) nach Anspruch 1, wobei die Suszeptoranordnung (2-3; 3) zur Benutzerkonfiguration und -modifikation eingerichtet ist, die mindestens eines einer Neuordnung, einer Hinzufügung, einer Entfernung und/oder eines Austauschs eines oder mehrerer Suszeptorelemente (3) durch einen Benutzer ermöglichen.
3. Garzubehör (1) nach Anspruch 1 oder 2, wobei die hochfrequente elektromagnetische Strahlung mindestens eine einer Funkfrequenz- und einer Mikrowellenfrequenzstrahlung umfasst, wobei die Funkfrequenz vorzugsweise zwischen 1 MHz und 300 MHz ausgewählt ist und die Mikrowellenfrequenz vorzugsweise zwischen 300 MHz und 300 GHz ausgewählt ist.
4. Garzubehör (1) nach einem der Ansprüche 1 bis 3, wobei die vordefinierte dielektrische Absorptions-

charakteristik eines Suszeptorelements (3) durch mindestens eines des Absorptionsvermögens, des Reflexionsvermögens (R) oder des Transmissionsvermögens des Suszeptorelements (3) für die zum Erwärmen verwendete hochfrequente elektromagnetische Strahlung definiert ist.

5. Garzubehör (1) nach Anspruch 4, wobei mindestens ein Suszeptorelement (3) der Suszeptoranordnung (2-3; 3) ein hohes dielektrisches Absorptionsvermögen oder Reflexionsvermögen (R) im Bereich von 60 % bis 100 % oder ein mittelgradiges dielektrisches Absorptionsvermögen oder Reflexionsvermögen (R) im Bereich von 30 % bis 60 % oder ein niedriges dielektrisches Absorptionsvermögen oder Reflexionsvermögen (R) im Bereich von 0 % bis 30 % umfasst.
6. Garzubehör (1) nach einem der Ansprüche 1 bis 5, umfassend eine Trägerbasis (2), die vorzugsweise für die hochfrequente elektromagnetische Strahlung im Wesentlichen transparent ist, wobei die Trägerbasis (2) optional mindestens einen, insbesondere mehrere, Halteabschnitte (10), insbesondere Sockel, umfasst, die jeweils zum Halten mindestens eines, vorzugsweise eines einzelnen, Suszeptorelements (3) in einer vom Benutzer abnehmbaren, insbesondere vom Benutzer entfernbaren, vom Benutzer austauschbaren und/oder vom Benutzer austauschbaren Weise konfiguriert sind, wobei der Halteabschnitt (10) vorzugsweise zum Halten eines Suszeptorelements (3) gemäß mindestens einer einer vordefinierten Position, einer vordefinierten Ausrichtung und einer vordefinierten Orientierung in Bezug auf den 2D-Trägerbereich konfiguriert ist.
7. Garzubehör (1) nach Anspruch 6, wobei die Trägerbasis (2) mehrere Vertiefungen (10) und/oder Sockel in einer Kachelanordnung, insbesondere in einer matrixartigen Anordnung, umfasst, wobei jede Vertiefung (10) oder jeder Sockel dazu konfiguriert ist, darin mindestens ein Suszeptorelement (3) aufzunehmen.
8. Garzubehör (1) nach einem der Ansprüche 1 bis 7, wobei die Suszeptorelemente (3) als Patches, Pads oder Kacheln implementiert sind, die für mindestens eine einer modularen und einer zumindest teilweise gegeneinander austauschbaren Baugruppe zum Überspannen mindestens eines Abschnitts des 2D-Trägerbereichs konfiguriert sind.
9. Garzubehör (1) nach Anspruch 8, wobei die Kacheln, Patches oder Pads eine rechteckige Form aufweisen, wobei eine Kachel-, Patch- oder Padfläche zum Überspannen eines Abschnitts der 2D-Trägerfläche geeignet ist, wobei vorzugsweise die Größe jeder Kachel-, Patch- oder Padfläche im We-

sentlichen einem ganzzahligen Vielfachen eines gegebenen Nennmaßes entspricht.

10. Garzubehör (1) nach einem der Ansprüche 1 bis 9, wobei zumindest einige der Suszeptorelemente (3) Verriegelungselemente (8, 9) umfassen, die zum Herstellen einer mechanischen Verbindung mit einem oder mehreren komplementären Verriegelungselementen (8, 9) eines oder mehrerer anderer Suszeptorelemente (3) und/oder Verriegelungselementen (8, 9), die an oder in dem Halteabschnitt (10) bereitgestellt sind, konfiguriert sind, wobei die Verriegelungselemente (8, 9) vorzugsweise an mindestens einem Umfangsabschnitt des Suszeptorelements (3) bereitgestellt sind und optional Verriegelungskerbene (8) und -ausbuchtungen (9) aufweisen, wie beispielsweise puzzleartige Verriegelungselemente.
11. Garzubehör (1) nach einem der Ansprüche 1 bis 10, wobei mindestens ein Suszeptorelement (3) mindestens ein Material oder eine Kombination von Materialien umfasst, die aus der Gruppe ausgewählt sind, die Folgendes umfasst: Keramik, Glaskeramik, Borosilikatglas, Metall.
12. Garzubehör (1) nach einem der Ansprüche 1 bis 11, wobei mindestens ein Suszeptorelement (3) eine resonante dielektrische Topologie, insbesondere mindestens eines einer resonanten dielektrischen 2D-Struktur, wie etwa einer frequenzselektiven Oberfläche, oder einer resonanten dielektrischen 3D-Struktur, wie etwa eines frequenzselektiven Gitters, umfasst.
13. Garzubehör (1) nach Anspruch 12, wobei die resonante dielektrische 2D- oder 3D-Struktur mindestens einen reflektierenden Abschnitt, der aus einem reflektierenden Material, insbesondere Metall, hergestellt ist, das für die hochfrequente elektromagnetische Strahlung reflektierend ist, und/oder mindestens einen transparenten Abschnitt (4, 5), der aus einem transparenten Material hergestellt ist, das für die hochfrequente elektromagnetische Strahlung im Wesentlichen transparent ist, umfasst, wobei der reflektierende Abschnitt (6) als eine Oberflächenschichtstruktur, wie etwa ein Laminat, auf einer oder mehreren transparenten Kacheln bereitgestellt ist, oder wobei der transparente Abschnitt als oder in Verbindung mit einem oder mehreren Ausschnitten (4) in einer oder mehreren reflektierenden Kacheln bereitgestellt ist, wobei die Kacheln optional auf einem im Wesentlichen transparenten Substrat angeordnet sind.
14. Garzubehör (1) nach Anspruch 12 oder 13, wobei die resonante dielektrische 2D- oder 3D-Struktur mehrere reflektierende und/oder transparente Abschnitte

umfasst, wobei die reflektierenden und/oder transparenten Abschnitte in einem regelmäßigen Muster, insbesondere einem Matrixmuster, bereitgestellt sind, wobei die reflektierenden und/oder transparenten Abschnitte eines Suszeptorelements (3) vorzugsweise die gleiche 2D- oder 3D-Form aufweisen.

15. Dielektrisches Gargerät (11), umfassend einen Hohlraum (12) und ein oder mehrere Heizelemente (13) zum dielektrischen Erwärmen eines oder mehrerer innerhalb des Hohlraums (12) platzierter Lebensmittelartikel durch Bestrahlen des Hohlraums (12) mit hochfrequenter elektromagnetischer Strahlung, wie etwa Funkfrequenz- oder Mikrowellenfrequenzstrahlung, und ein Garzubehör (1) nach mindestens einem der Ansprüche 1 bis 14, das vorzugsweise zum entfernbaren Platzieren innerhalb des Hohlraums (12) zum Tragen mindestens eines Lebensmittelartikels darauf, während es mit der hochfrequenten elektromagnetischen Strahlung bestrahlt wird, konfiguriert ist.
16. Teilesatz (2-3; 3), umfassend mehrere Suszeptorelemente (3), wobei jedes Suszeptorelement (3) eine ausgewählte vordefinierte dielektrische Absorptionscharakteristik (R) für hochfrequente elektromagnetische Strahlung in dem Funkfrequenz- und/oder Mikrowellenfrequenzbereich aufweist, die zum Erwärmen oder Garen von Lebensmitteln geeignet ist, wobei die Suszeptorelemente (3) zum Zusammenbauen einer Suszeptoranordnung (2-3, 3) eines Garzubehörs (1) nach einem der Ansprüche 1 bis 14 konfiguriert sind, wobei die zusammengebauten Suszeptorelemente (3) den 2D-Trägerkachelbereich überspannen.
17. Teilesatz (2-3; 3) nach Anspruch 16, wobei jedes Suszeptorelement (3) eine Kennung umfasst, die eine vordefinierte dielektrische Absorptionscharakteristik (R) angibt.

## Revendications

1. Accessoire de cuisson (1) pour un chauffage diélectrique haute fréquence, conçu pour être placé dans une cavité de chauffage diélectrique (12) d'un appareil de cuisson (11) et conçu pour supporter un ou plusieurs produits alimentaires tout en étant irradié par des rayonnements électromagnétiques haute fréquence pour chauffer le ou les produits alimentaires dans la cavité de chauffage (12), l'accessoire de cuisson (1) comprenant un agencement de suscepteur (2-3 ; 3) doté d'éléments suscepteurs (3), chaque élément suscepteur (3) ayant une première caractéristique d'absorption diélectrique (R) prédéfinie pour les rayonnements électromagnétiques

- haute fréquence, **caractérisé en ce que** les éléments suscepteurs sont disposés pour s'étendre sur une surface de support en plaques en 2D pour le ou les produits alimentaires.
2. Accessoire de cuisson (1) selon la revendication 1, l'agencement de suscepteur (2-3 ; 3) étant conçu pour une configuration et une modification par un utilisateur permettant un réagencement et/ou un ajout et/ou un retrait et/ou un remplacement d'un ou plusieurs éléments suscepteurs (3) par un utilisateur.
  3. Accessoire de cuisson (1) selon la revendication 1 ou 2, les rayonnements électromagnétiques comprenant au moins l'un d'un rayonnement radiofréquence et d'un rayonnement hyperfréquence, la radiofréquence étant de préférence sélectionnée entre 1 MHz et 300 MHz, et l'hyperfréquence étant de préférence sélectionnée entre 300 MHz et 300 GHz.
  4. Accessoire de cuisson (1) selon l'une quelconque des revendications 1 à 3, la caractéristique d'absorption diélectrique prédéfinie d'un élément suscepteur (3) étant définie par au moins l'une d'une absorptivité, d'une réflectivité (R) ou d'une transmittivité de l'élément suscepteur (3) pour les rayonnements électromagnétiques haute fréquence utilisés pour le chauffage.
  5. Accessoire de cuisson (1) selon la revendication 4, dans lequel au moins un élément suscepteur (3) de l'agencement de suscepteur (2-3 ; 3) comprend une absorptivité ou une réflectivité (R) diélectrique élevée dans la plage comprise entre 60 % et 100 %, ou une absorptivité ou une réflectivité (R) diélectrique modérée dans la plage comprise entre 30 % et 60 %, ou une absorptivité ou une réflectivité (R) diélectrique faible dans la plage comprise entre 0 % et 30 %.
  6. Accessoire de cuisson (1) selon l'une quelconque des revendications 1 à 5, comprenant une base de support (2) qui est de préférence sensiblement transparente aux rayonnements électromagnétiques haute fréquence, la base de support (2) comprenant facultativement au moins une, en particulier une pluralité de, sections de retenue (10), en particulier des socles, chacune configurée pour retenir au moins un, de préférence un seul, élément suscepteur (3) de manière détachable par un utilisateur, en particulier, de manière à pouvoir être retirée, échangée et/ou interchangeée par un utilisateur, la section de retenue (10) étant de préférence conçue pour retenir un élément suscepteur (3) selon au moins l'un d'une position prédéfinie, d'un alignement prédéfini et d'une orientation prédéfinie par rapport à la surface de support en 2D.
  7. Accessoire de cuisson (1) selon la revendication 6, la base de support (2) comprenant une pluralité de creux (10) et/ou de socles agencés en plaques, en particulier en un réseau de type matrice, chaque creux (10) ou socle étant conçu pour recevoir en son sein au moins un élément suscepteur (3).
  8. Accessoire de cuisson (1) selon l'une quelconque des revendications 1 à 7, dans lequel les éléments suscepteurs (3) sont mis en place en tant que carrés, disques ou plaques conçus pour au moins l'un d'un ensemble modulaire et, au moins en partie, d'un ensemble mutuel interchangeable pour s'étendre sur au moins une section de la surface de support en 2D.
  9. Accessoire de cuisson (1) selon la revendication 8, dans lequel les plaques, carrés ou disques ont une forme rectangulaire, une surface de la plaque, du carré ou du disque étant conçue pour s'étendre sur une section de la surface de support en 2D, dans lequel de préférence, la taille de chaque plaque, carré ou disque correspond sensiblement à un multiple entier d'une taille de base donnée.
  10. Accessoire de cuisson (1) selon l'une quelconque des revendications 1 à 9, au moins certains des éléments suscepteurs (3) comprenant des éléments de verrouillage (8, 9) conçus pour établir une interconnexion mécanique avec un ou plusieurs éléments de verrouillage (8, 9) complémentaires d'un ou plusieurs autres éléments suscepteurs (3) et/ou des éléments de verrouillage (8, 9) placés sur ou dans la section de retenue (10), dans lequel les éléments de verrouillage (8, 9) sont de préférence placés sur au moins une section périphérique de l'élément suscepteur (3), et comprennent facultativement des encoches (8) et des renflements (9) de verrouillage, par exemple des éléments de verrouillage de type casse-tête.
  11. Accessoire de cuisson (1) selon l'une quelconque des revendications 1 à 10, au moins un élément suscepteur (3) comprenant au moins un matériau ou une combinaison de matériaux sélectionnés parmi le groupe comprenant : la céramique, la vitrocéramique, le verre borosilicate, le métal.
  12. Accessoire de cuisson (1) selon l'une quelconque des revendications 1 à 11, au moins un élément suscepteur (3) comprenant une topologie diélectrique résonante, en particulier au moins l'une d'une structure diélectrique résonante en 2D, telle qu'une surface de sélection de fréquence, ou d'une structure diélectrique résonante en 3D, telle qu'une grille de sélection de surface.

13. Accessoire de cuisson (1) selon la revendication 12, la structure en 2D ou 3D diélectrique résonante comprenant au moins une section réflectrice constituée d'un matériau réflecteur, en particulier un métal, qui réfléchit les rayonnements électromagnétiques haute fréquence, et/ou au moins une section transparente (4, 5) constituée d'un matériau transparent qui est sensiblement transparent aux rayonnements électromagnétiques haute fréquence, dans lequel la section réflectrice (6) est fournie sous forme de structure en couche de surface, telle qu'une lame, sur une ou plusieurs plaques transparentes, ou dans lequel la section transparente est fournie sous forme de ou en liaison avec une ou plusieurs découpes (4) dans une ou plusieurs plaques réflectrices, les plaques étant facultativement disposées sur un substrat sensiblement transparent. 5  
10  
15
14. Accessoire de cuisson (1) selon la revendication 12 ou 13, la structure en 2D ou en 3D diélectrique résonante comprenant une pluralité de sections réflectrices et/ou transparentes, dans lequel les sections réflectrices et/ou transparentes sont placées en un motif régulier, en particulier un motif en matrice, les sections réflectrices et/ou transparentes d'un élément susceptible (3) ayant de préférence la même forme en 2D ou en 3D. 20  
25
15. Appareil de cuisson diélectrique (11) comprenant une cavité (12) et un ou plusieurs éléments chauffants (13) pour un chauffage diélectrique d'un ou plusieurs produits alimentaires placés à l'intérieur de la cavité (12) par irradiation de la cavité (12) par des rayonnements électromagnétiques haute fréquence, tels que des rayonnements radiofréquence ou hyperfréquence, et un accessoire de cuisson (1) selon l'une quelconque des revendications 1 à 14 de préférence conçu pour un placement amovible à l'intérieur de la cavité (12) pour supporter au moins un produit alimentaire tout en étant irradié par les rayonnements électromagnétiques haute fréquence. 30  
35  
40
16. Kit de pièces (2-3 ; 3) comprenant une pluralité d'éléments susceptibles (3), chaque élément susceptible (3) ayant une caractéristique d'absorption diélectrique (R) prédéfinie sélectionnée pour les rayonnements électromagnétiques haute fréquence dans la plage de radiofréquences et/ou d'hyperfréquences adaptée au chauffage ou à la cuisson d'aliments, dans lequel les éléments susceptibles (3) sont conçus pour assembler un agencement de susceptible (2-3 ; 3) d'un accessoire de cuisson (1) selon l'une quelconque des revendications 1 à 14 dans lequel les éléments susceptibles (3) assemblés s'étendent sur la surface de support en plaques en 2D. 45  
50  
55
17. Kit de pièces (2-3 ; 3) selon la revendication 16, chaque élément susceptible (3) comprenant un identifiant indiquant une caractéristique d'absorption diélectrique (R) prédéfinie.

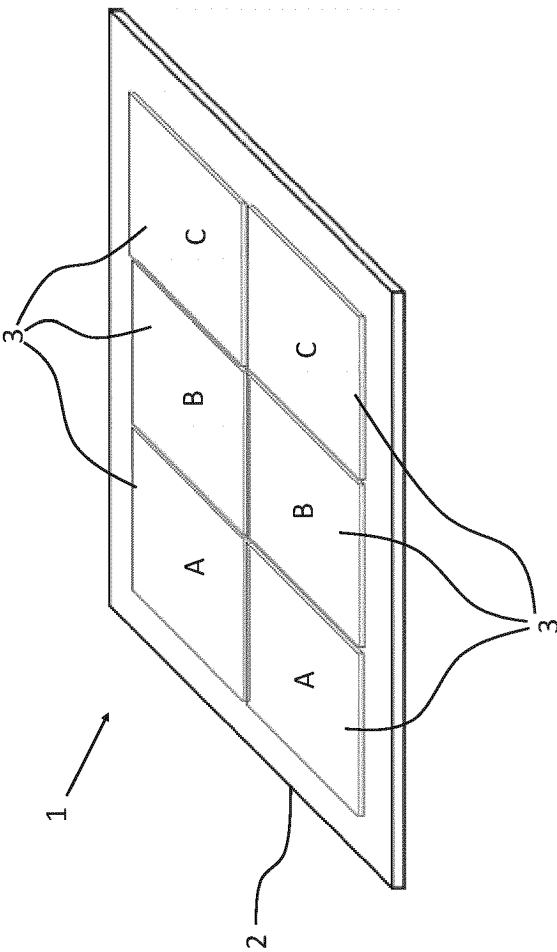

FIG. 1

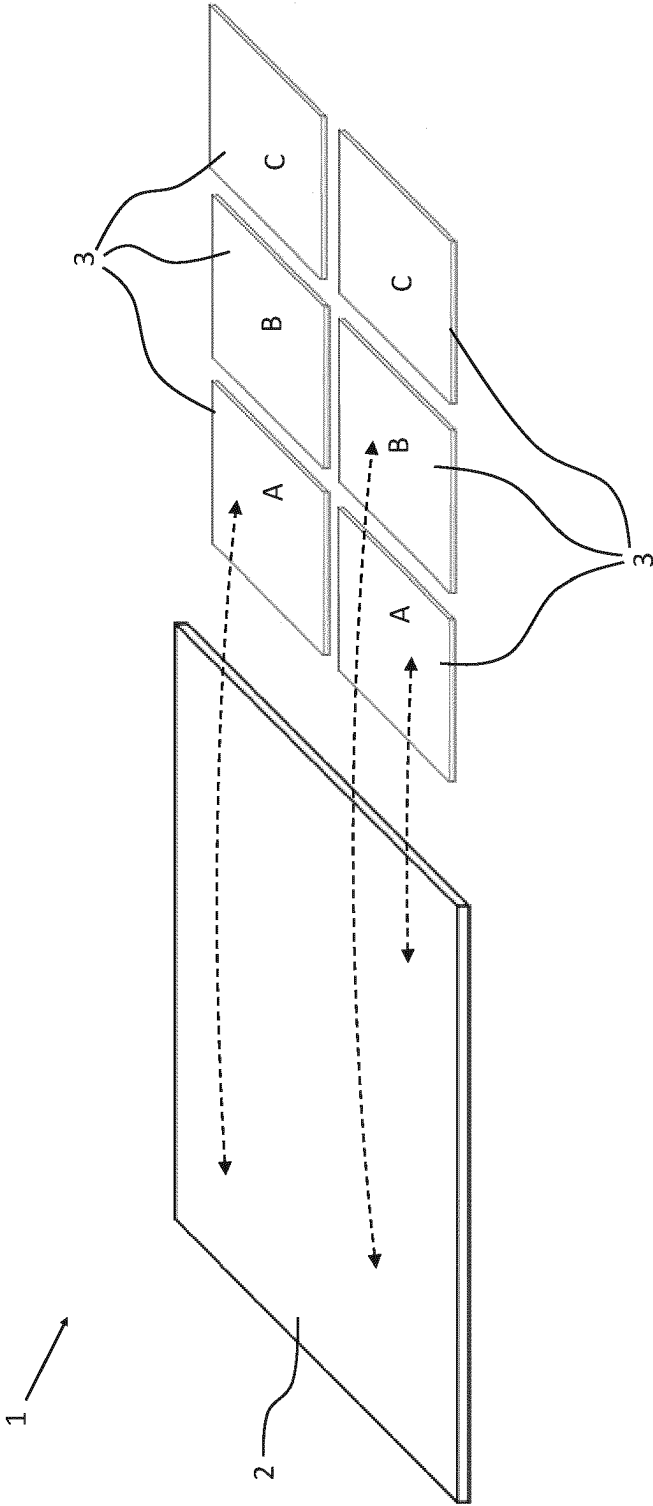

FIG. 2

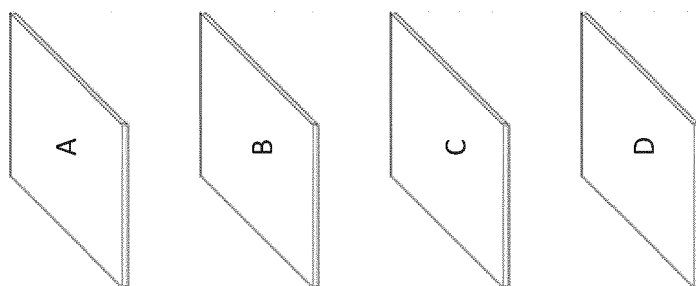

FIG. 3

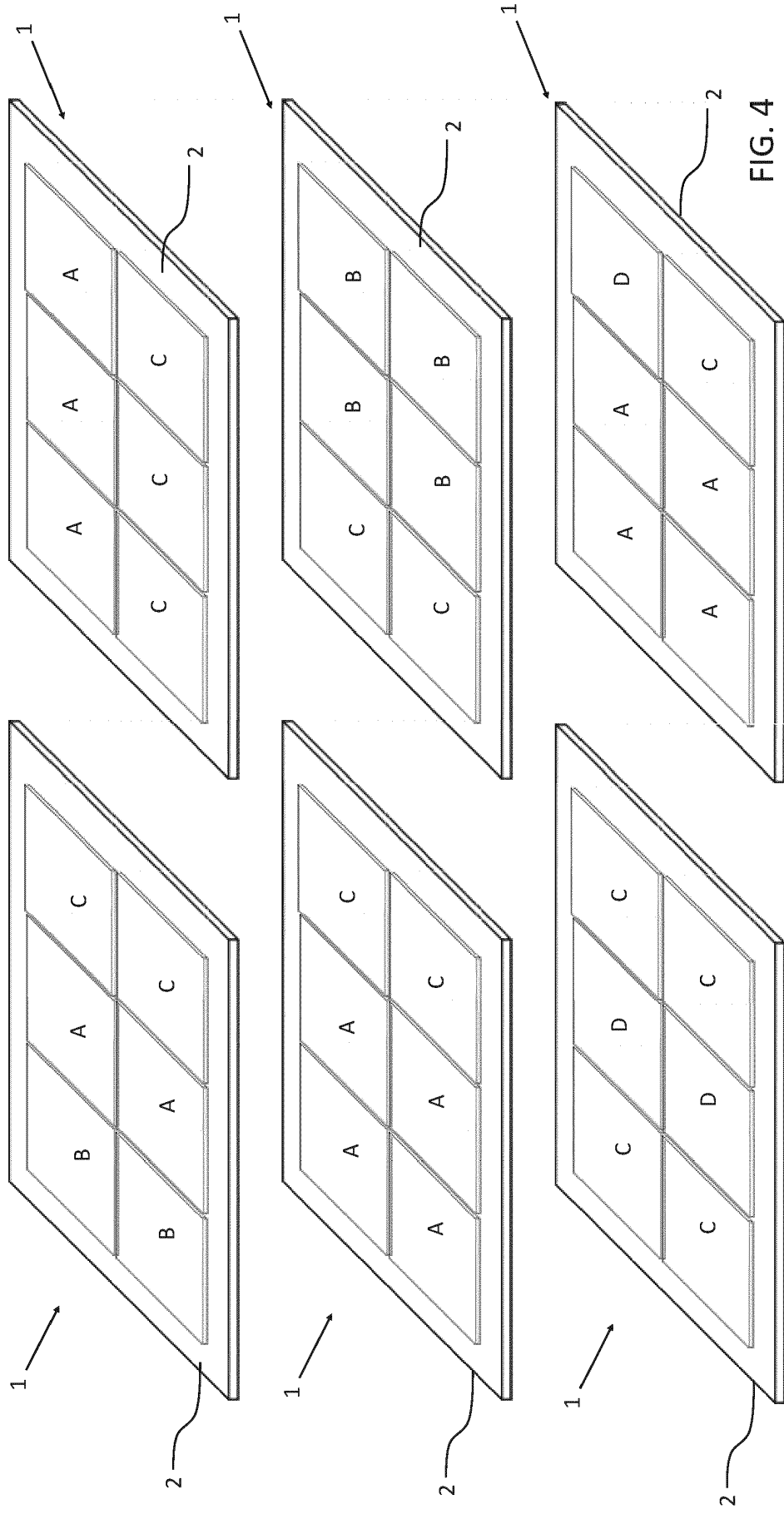

FIG. 4

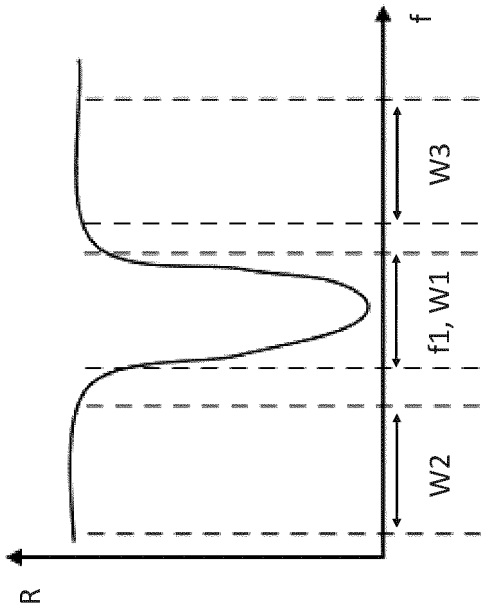

FIG. 5

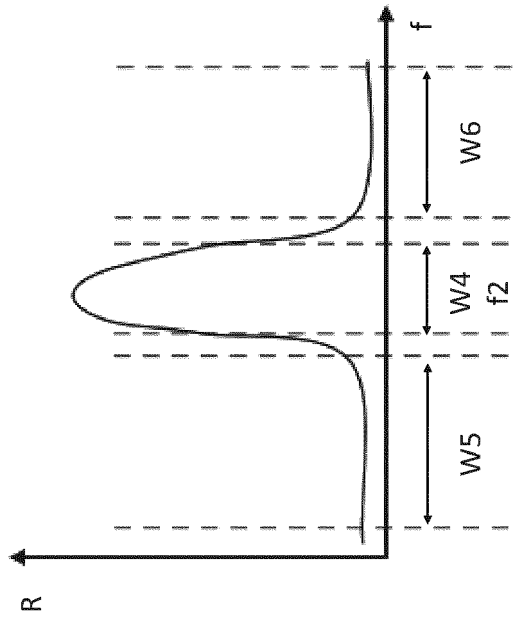
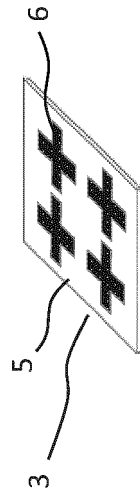

FIG. 6



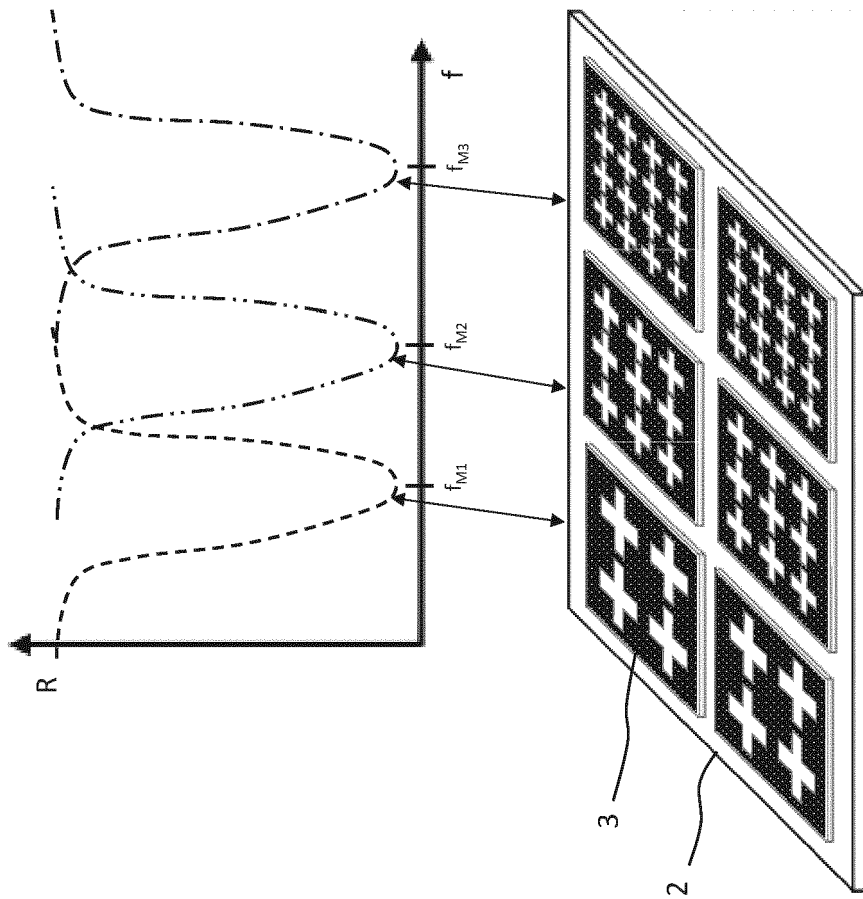

FIG. 7

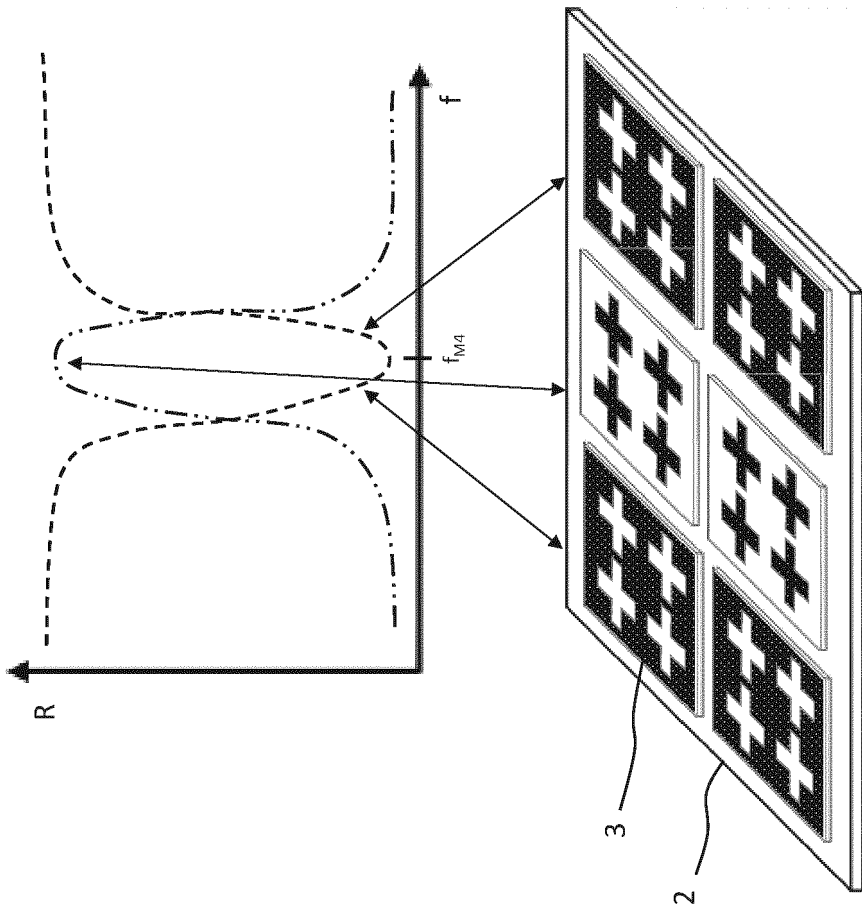

FIG. 8

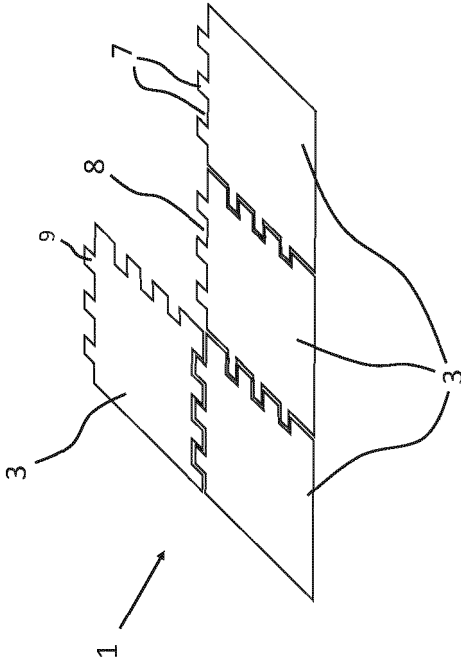
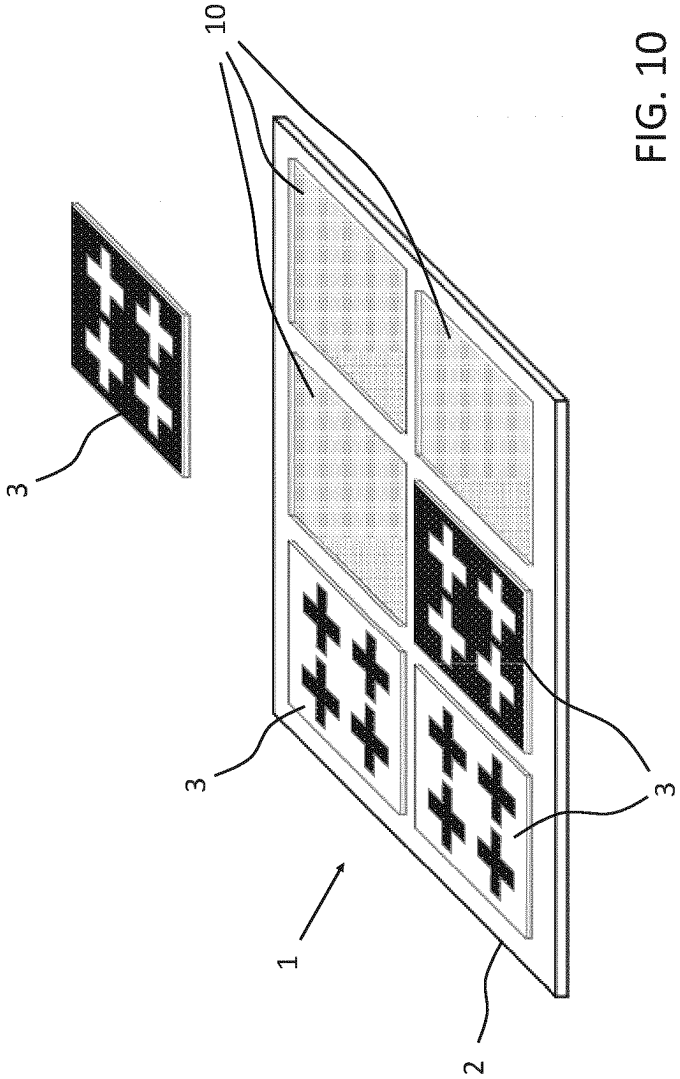

FIG. 9



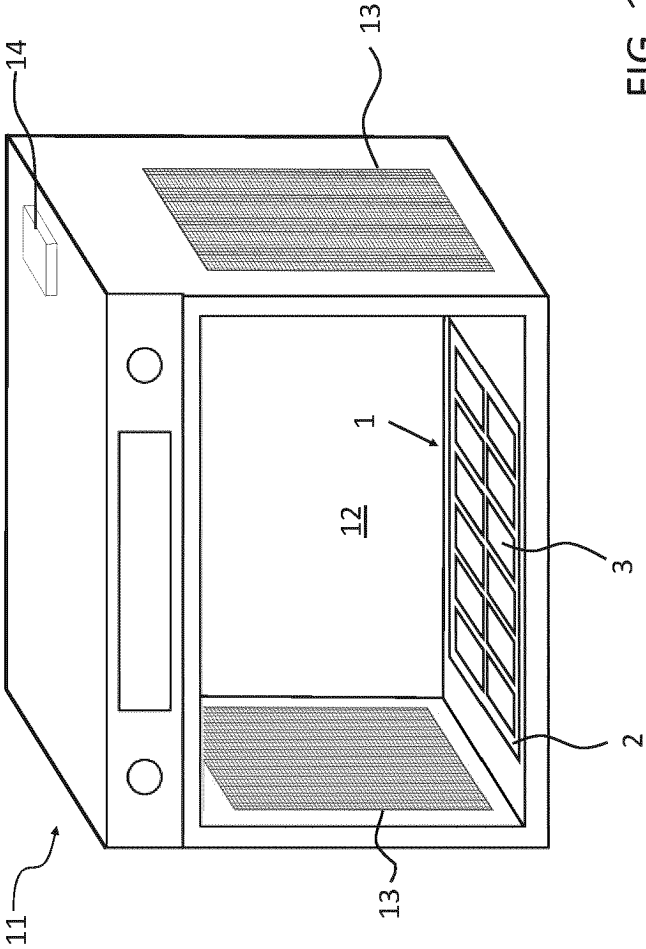

FIG. 11

**REFERENCES CITED IN THE DESCRIPTION**

*This list of references cited by the applicant is for the reader's convenience only. It does not form part of the European patent document. Even though great care has been taken in compiling the references, errors or omissions cannot be excluded and the EPO disclaims all liability in this regard.*

**Patent documents cited in the description**

- WO 2018202376 A1 [0002]
- WO 9015710 A1 [0003]
- EP 3095297 B1 [0004]
- US 5466917 A [0005]
- DE 102014104796 A1 [0006]
- WO 2016192802 A1 [0007]