



US 20150226299A1

(19) **United States**

(12) **Patent Application Publication**
Cooper et al.

(10) **Pub. No.: US 2015/0226299 A1**

(43) **Pub. Date: Aug. 13, 2015**

(54) **BALL TYPE CVT/IVT INCLUDING PLANETARY GEAR SETS**

Publication Classification

(71) Applicant: **Dana Limited**, Maumee, OH (US)

(51) **Int. Cl.**
F16H 37/08 (2006.01)
F16H 15/52 (2006.01)

(72) Inventors: **Kenneth E. Cooper**, Toledo, OH (US);
Timothy J. Morscheck, Portage, MI (US);
Andrew W. Phillips, Rochester, MI (US)

(52) **U.S. Cl.**
CPC *F16H 37/0853* (2013.01); *F16H 15/52* (2013.01); *F16H 2037/0873* (2013.01)

(21) Appl. No.: **14/425,842**

(57) **ABSTRACT**

(22) PCT Filed: **Sep. 3, 2013**

(86) PCT No.: **PCT/US13/57838**

§ 371 (c)(1),

(2) Date: **Mar. 4, 2015**

Disclosed herein are power transmissions having one or more operational modes, for example, a continuously variable transmission (CVT) mode, an infinitely variable transmission (IVT) mode, and an WT/CVT mode, that can be selected for by engaging different clutches and brakes. Disclosed herein are power transmissions comprising a power input shaft, one or more planetary gear sets, a variator (such as a CVT), and one or more clutches and brakes. In some embodiments, a first brake selects an WT mode, a second brake selects a CVT mode, and a third brake selects an WT/CVT mode.

Related U.S. Application Data

(60) Provisional application No. 61/697,912, filed on Sep. 7, 2012, provisional application No. 61/783,853, filed on Mar. 14, 2013.

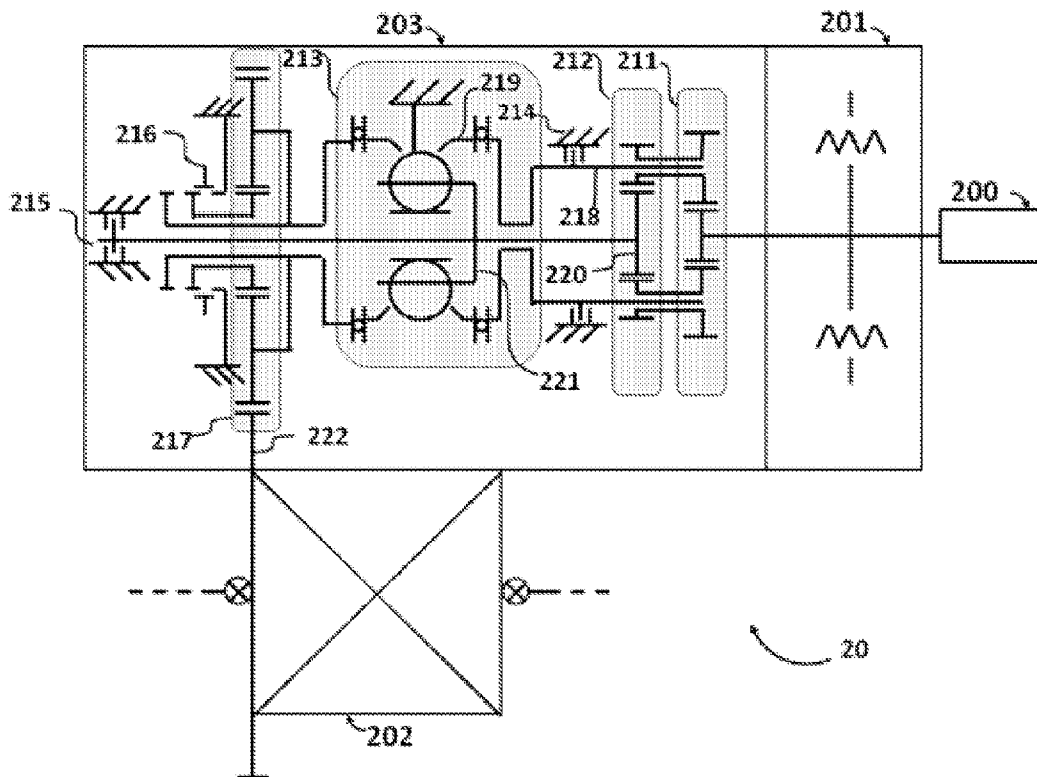

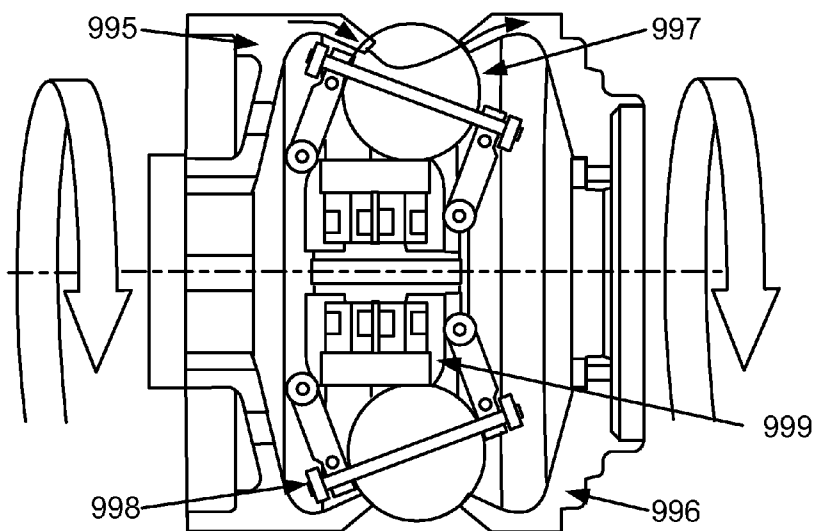

FIG. 1

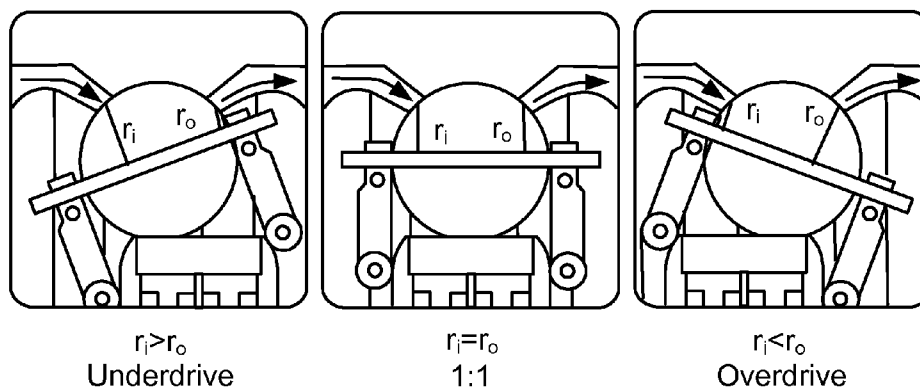

FIG. 2

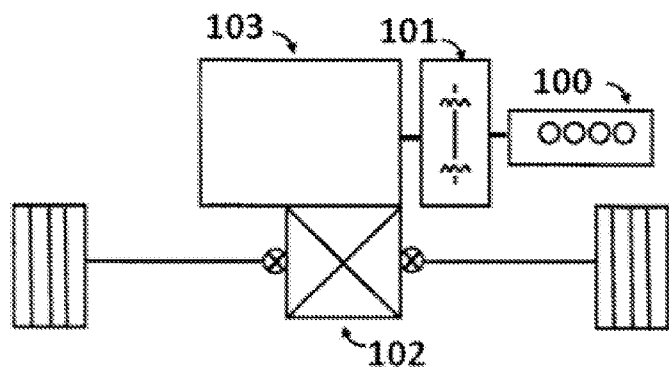

FIG. 3

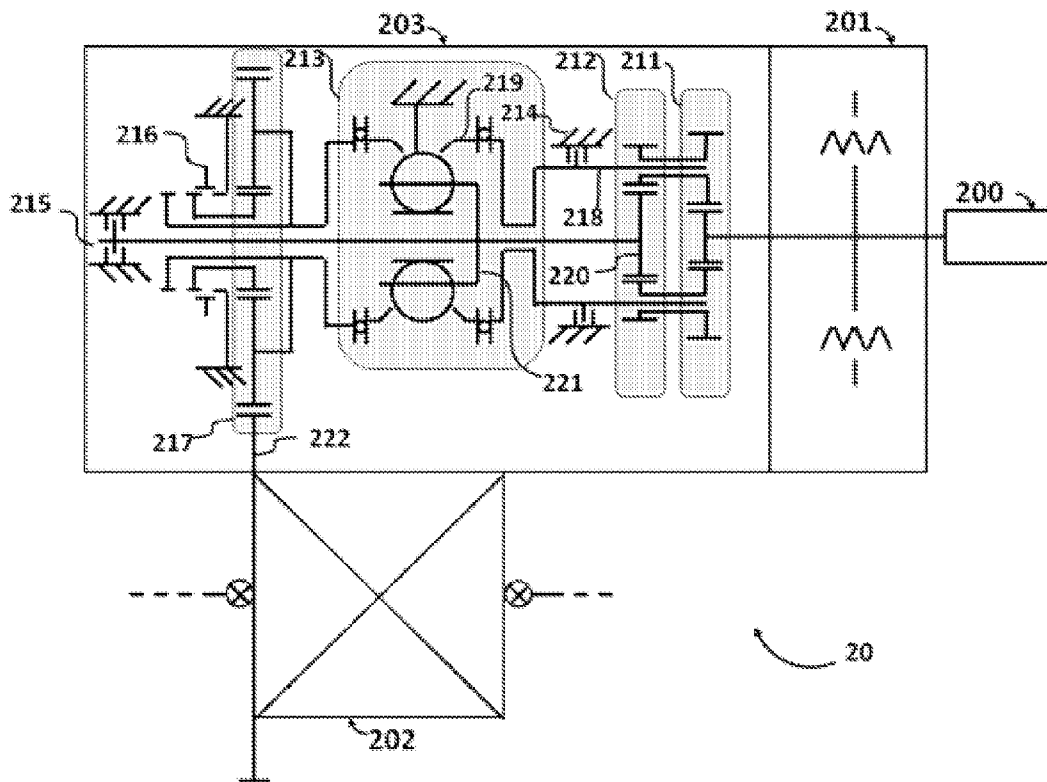

FIG. 4

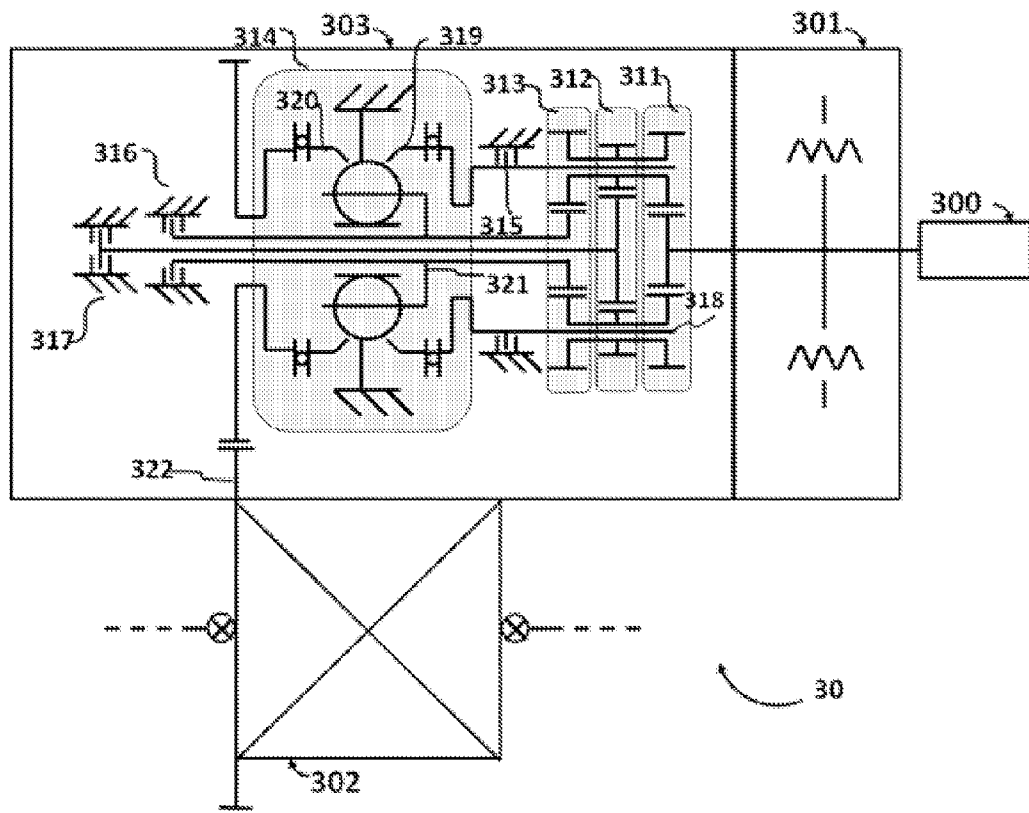

FIG. 5

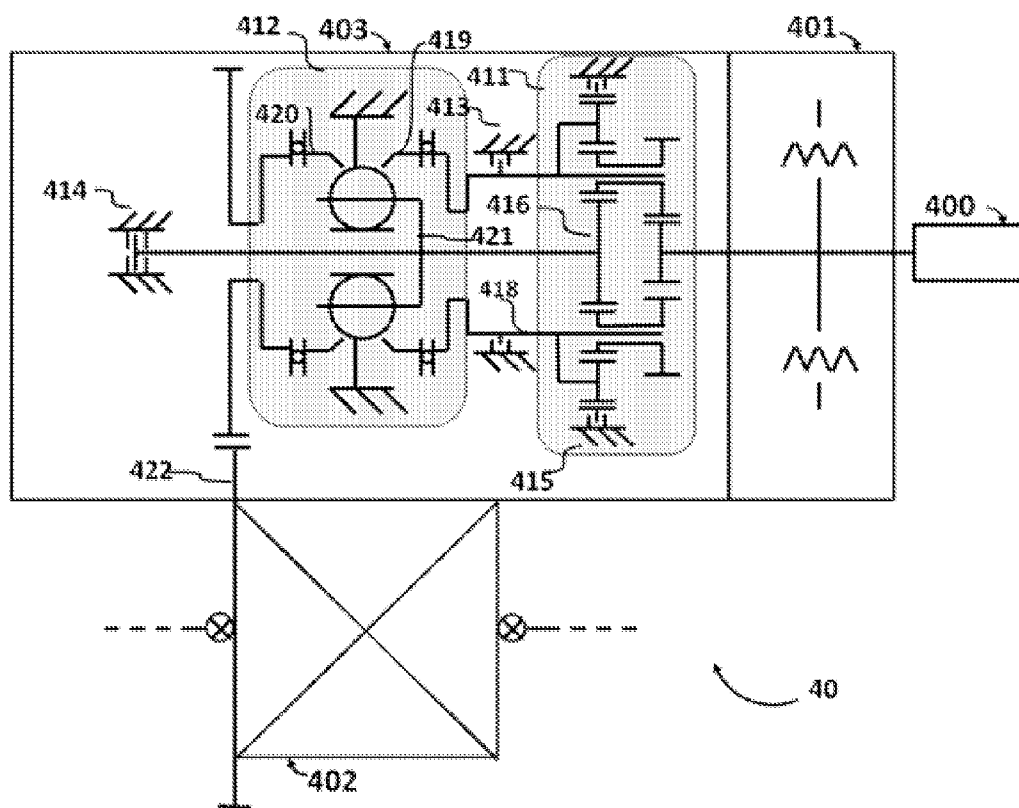

FIG. 6

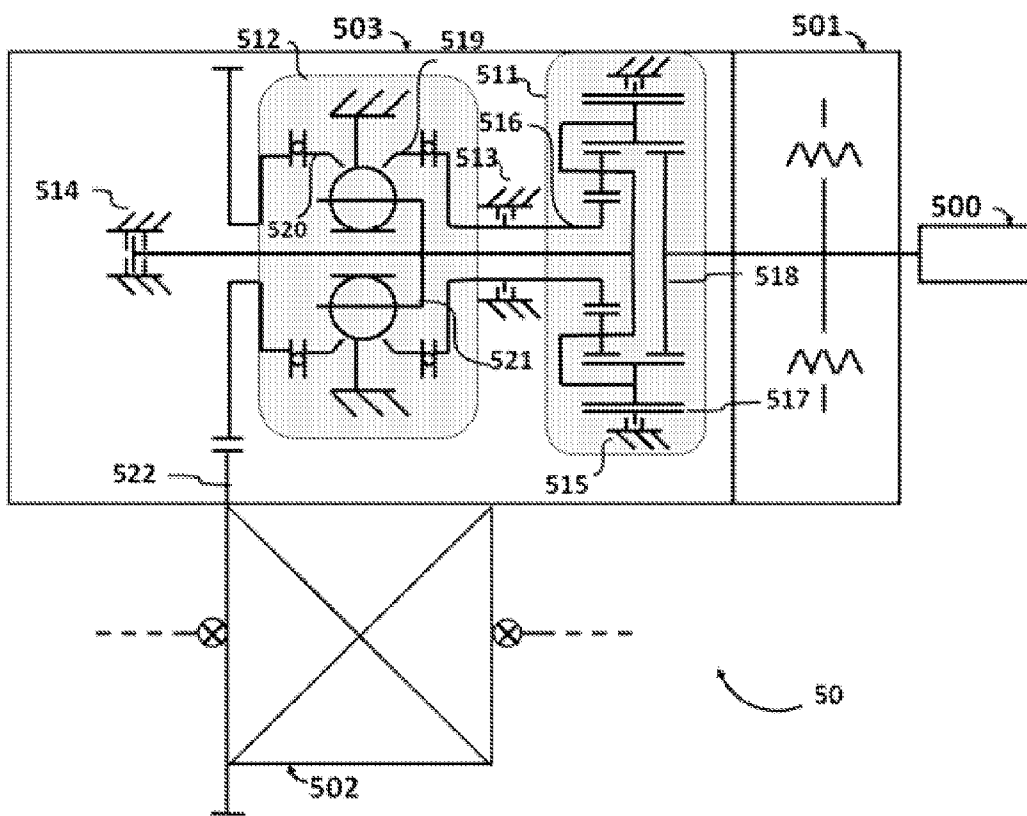

FIG. 7

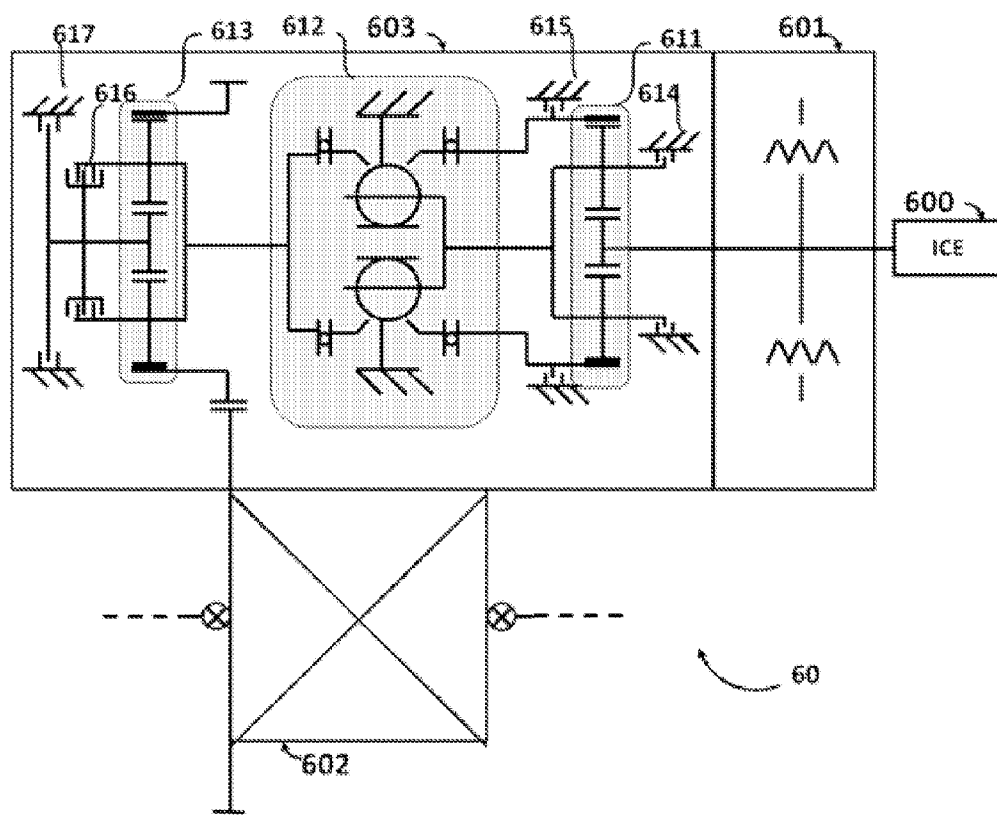

FIG. 8

BALL TYPE CVT/IVT INCLUDING PLANETARY GEAR SETS

CROSS-REFERENCE

[0001] This application claims the benefit of U.S. Provisional Application No. 61/697,912, filed Sep. 7, 2012 and U.S. Provisional Application No. 61/783,853, filed Mar. 14, 2013, which applications are incorporated herein by reference.

BACKGROUND OF THE INVENTION

[0002] Automatic and manual transmissions are commonly used on automobile vehicles. Such transmissions have become more and more complicated since the engine speed has to be adjusted to limit the consumption and the emissions of the vehicle. The finer control of the engine speed in usual transmissions can typically only be accomplished by adding gears and increasing the overall complexity and cost. As a result, 6-speed manual transmissions have become as frequent as 8 or 9 speed automatic transmissions.

SUMMARY OF THE INVENTION

[0003] Systems, devices, and methods are provided for transmitting power in a smoother and more efficient manner, preferably with less or smaller components. In some embodiments, power transmissions disclosed herein have one or more operational modes, e.g., a continuously variable transmission (CVT) mode, an infinitely variable transmission (IVT) mode, and an IVT/CVT mode. In some embodiments, the operational modes are selected for by engaging different clutches and/or brakes.

[0004] Described herein, in certain embodiments, is an apparatus for power transmission. In some embodiments, the power transmission apparatus comprises a power input shaft, one or more planetary gear sets, a variator, and one or more clutches and brakes (also called brake clutches). In some embodiments, a first planetary gear set is mechanically coupled to the power input shaft. In some embodiments, the variator is mechanically coupled to the some of the planetary gear sets. In some embodiments, the one or more clutches and brakes are to be used for switching among a plurality of operational modes of the power transmission apparatus.

[0005] In some embodiments, the components of the power transmission have various configurations and comprise a variety of different types of parts. In some embodiments, the one or more clutches and brakes are configured to be selectively engaged or released to switch between the modes of the power transmission apparatus. In some embodiments, the gear set comprises a ravigneaux-like gear set, a dual sun planetary gear set, or a three sun planetary gear set. In some embodiments, the variator is coupled to a sun, a ring or a planet carrier of the planetary gear set. In some embodiments, the variator comprises a continuously variable transmission (CVT), such as a traction type, also known as ball-type CVT. In some embodiments, the power transmission further comprises a first and second ball ramp disposed on either side of the variator for providing a clamping force for torque transfer. In some embodiments, the power input shaft is coupled to a damper and the output of an internal combustion engine.

[0006] In some embodiments, the one or more clutches and brakes comprises a first clutch or brake for selecting an infinitely variable transmission (IVT) mode of the power transmission apparatus. In some embodiments, the first clutch or

brake is configured to couple to an output of a planet gear of the gear set. In some embodiments, the one or more clutches or brakes comprises a second clutch or brake for selecting a continuously variable transmission (CVT) mode of the power transmission apparatus. In some embodiments, the second clutch or brake is configured to couple to an output of a sun gear of the gear set. In some embodiments, the one or more clutches or brake comprises a third clutch or brake for selecting an infinitely and continuously variable transmission (IVT/CVT) mode of the power transmission apparatus. In some embodiments, the third clutch or brake is configured to couple to a ring gear or a sun of the gear set. In some embodiments, the one or more clutches comprises an overdrive clutch or brake for affecting a speed increase. In some embodiments, the one or more clutches comprise a direct drive clutch.

[0007] In some embodiments, the power transmission apparatus further comprises a power output mechanically coupled to the variator. In some embodiments, the power output comprises a power output ring for transmitting power from the variator to a differential box. In some embodiments, the power output comprises a power output shaft. In some embodiments, the power transmission further comprises an output gear set mechanically coupled to the power output shaft for transmitting power from the variator to a differential box.

INCORPORATION BY REFERENCE

[0008] All publications, patents, and patent applications mentioned in this specification are herein incorporated by reference to the same extent as if each individual publication, patent, or patent application was specifically and individually indicated to be incorporated by reference.

BRIEF DESCRIPTION OF THE DRAWINGS

[0009] The novel features of the invention are set forth with particularity in the appended claims. A better understanding of the features and advantages of the present invention will be obtained by reference to the following detailed description that sets forth illustrative embodiments, in which the principles of the invention are utilized, and the accompanying drawings of which:

[0010] FIG. 1 is a cutaway view of a currently known and used continuously variable transmission (CVT);

[0011] FIG. 2 is a magnified cutaway view of a ball and ring of the CVP of FIG. 1;

[0012] FIG. 3 is a block diagram of a transmission based on CVP of FIG. 1 as used in a motor vehicle transmission;

[0013] FIG. 4 is a block diagram of a multi-mode transmission according to an embodiment of the present disclosure;

[0014] FIG. 5 is a block diagram of a multi-mode transmission according to another embodiment of the present disclosure;

[0015] FIG. 6 is a block diagram of a multi-mode transmission according to yet another embodiment of the present disclosure; and

[0016] FIG. 7 is a block diagram of a multi-mode transmission according to a further embodiment of the present disclosure

[0017] FIG. 8 is a block diagram of a multi-mode transmission according to a further embodiment of the present disclosure

DETAILED DESCRIPTION OF THE INVENTION

[0018] Automatic and manual transmissions commonly used on automobile vehicles are Continuously Variable Transmissions or CVTs. Such CVTs include many types, such as belts with variable pulleys, toroidal, and conical. The principle of a CVT is that it enables the engine to run at its most efficient rotation speed by changing steplessly the transmission ratio in function of the speed of the vehicle. If needed, for example, when accelerating, the CVT can also shift to a ratio providing more power. A CVT can change the ratio from the minimum to the maximum ratio without any interruption of the power transmission, at the opposite of usual transmissions which require an interruption of the power transmission by disengaging to shift of ratio. A specific use of CVTs is the Infinite Variable Transmission or IVT. Where the CVT is limited at positive speed ratios, the IVT configuration can perform a neutral gear and even reverse steplessly. A CVT can be used as an IVT in some driveline configurations.

[0019] Described herein are driveline configurations based on a ball type CVT, also known as CVP (Constant Variable Planetary), for which patents were applied for by Fallbrook Technologies, Inc. under the references US20040616399P and AU2011224083A1. This CVT is composed of a certain number of balls, depending on the application, two discs with a conical surface contact with the balls, as input and output, and an idler as shown in FIG. 1. This CVT is composed of a certain number of balls, depending on the application, two discs with a conical surface contact with the balls, as input **995** and output **996**, and an idler **999** as shown in FIG. 1. The balls **997** are mounted on axles **998**, themselves held in a cage or carrier allowing changing the ratio by tilting the ball's axles. Other types of ball CVTs also exist, including the Milner Continuous Variable Transmission (MCMVT) (MCMVT).

[0020] The working principle is shown on FIG. 2. The CVP itself works with a traction fluid. The lubricant between the ball and the conical rings acts as a solid at high pressure, transferring the power from the input ring, through the balls, to the output ring. By tilting the ball's axis, the ratio can be changed between input and output. When the axis is horizontal the ratio is one, when the axis is tilted the distance between the axis and the contact point change, modifying the overall ratio. All the ball's axes are tilted at the same time with a mechanism included in the cage.

[0021] In an automobile, the CVT is used to replace a traditional transmission and is located between the engine **100** and the differential **102** as shown on FIG. 3. In some instances, a torsional damper **101** is introduced between the engine **100** and the CVT **103** to avoid transferring torque peaks and vibrations that could seriously damage the CVT. In some configurations, this damper is coupled with a clutch for the starting function.

[0022] In some instances, the continuously variable transmission (CVT) is less than ideal. Power ratios may not be the most effective and efficient, power transmission may be frequently interrupted, and the transmissions may involve the use of bulky and heavy parts. Therefore, improved continuously variable transmissions (CVT) overcoming at least some of these problems are desired.

[0023] Systems, devices, and methods are provided for transmitting power in a smoother and more efficient manner. In some embodiments, this is accomplished with fewer or smaller components. In some embodiments, power transmissions disclosed herein have one or more operational modes,

e.g., a continuously variable transmission (CVT) mode, an infinitely variable transmission (IVT) mode, and an IVT/CVT mode, that are selected for by engaging different clutches or brakes. In some embodiments, the apparatus allows for mode shifting between the continuously variable (CVT) mode and infinitely variable (IVT) mode with a minimum number of clutches and brakes.

[0024] Concept 1c/

[0025] In an automobile **20**, the CVT **203** is used to replace a traditional transmission and is located between the engine **200** and the differential **202**. In some instances, a torsional damper **201** is introduced between the engine **200** and planetary gears **211** and **212** as shown on FIG. 4. Configuration 1c/ (FIG. 4) uses a dual sun planetary **211** and **212** before going to the variator **213**. In the dual sun planetary, the planets of first plane of gears planetary **211** of second plane of gears planetary **212** are made of a single piece. In some embodiments, the variator output is linked to an additional planetary **217**. In some embodiments, this planetary is locked to turn with a 1:1 ratio by applying the clutch **216** to lock its sun and planet carrier together. In some embodiments, a speed increase is achieved by having more spread by applying the overdrive clutch **216** to lock the sun of the planetary to the ground. In some embodiments, the ring of this planetary is then linked to the final drive **222** and differential **202**. In some embodiments, the second ring of the variator is linked to the planet carrier of the third planetary. In some embodiments, the configuration comprises two brakes, one for IVT mode **214** and one for CVT mode **215**. In some embodiments, the central part of that configuration comprises the variator described above. In some embodiments, a ball ramp on each side of the variator provides the clamping force necessary to transfer the torque.

[0026] In some embodiments, the carrier **218** of the dual sun planetary is linked to the variator input ring **219**. In some embodiments, the carrier **218** of the dual sun planetary is connected to the housing in IVT mode by applying the IVT clutch **214**. In some embodiments, the sun of the second planetary **220** is linked to the carrier of the variator **221**. In some embodiments, the sun of the second planetary **220** is connected to the housing in CVT mode by applying the CVT clutch **215**. In some embodiments, the overall ratio is typically the product of the dual sun planetary ratio, the variator ratio, the output planetary **217** ratio and the final drive ratio **222**. In some embodiments, standstill, very low vehicle speeds and reverse is achieved by the IVT mode of the variator.

[0027] In some embodiments, the transition between the two modes (CVT and IVT) is simply done by releasing one brake and closing the other. Furthermore, the clutch **216** of the output planetary might be used to select a ratio 1:1 in the output planetary **217** or an overdrive ratio. The transition between these two additional ratios is simply done by changing the parts engaged by the clutch **216**. In some embodiments, this device is able to change continuously its ratio to provide the best ratio achievable for the engine in function of the objectives of consumption or power. In certain instances, in a manual or automatic transmission, only some predetermined and discrete ratios are available and an interruption of the power transmission is needed to shift the ratio. In certain instances, the only interruption of power in this device is to change modes. Other advantages include, but are not limited to: a small final drive (in one step, not needing a countershaft) and cost effectiveness of the system. In some embodiments,

spread is higher than traditional gearboxes by adding the third planetary, which improves global efficiency of the vehicle. In some embodiments, the apparatus allows for mode shifting between the continuously variable (CVT) mode and infinitely variable (IVT) mode with a minimum number of brakes.

[0028] Concept 1d/

[0029] In an automobile **30**, the CVT **303** is used to replace a traditional transmission and is located between the engine **300** and the differential **302**. In some instances, a torsional damper **301** is introduced between the engine **300** and planetary gears **311**, **312** and **313** as shown on FIG. 5. Configuration 1d/ (FIG. 5) uses a three sun planetary ((**311**), (**312**), and (**313**)) before going to the variator (**314**). In the three sun planetary, the planets of first plane of gears (planetary (**311**)) of second plane of gears (planetary (**312**)) and third plane of gears (planetary (**313**)) are made of a single piece. In some embodiments, the variator output ring (**320**) is then linked to the final drive (**322**) and differential. In some embodiments, the configuration comprises three brake clutches, one for IVT mode (**315**); one for CVT mode (**316**) and one for an IVT/CVT mode (**317**) where the variator input ring (**319**) and the variator carrier (**321**) are both driven. In some embodiments, the central part of this configuration is the variator described above. In some embodiments, a ball ramp on each side of the variator provides the clamping force necessary to transfer the torque.

[0030] In some embodiments, the carrier (**318**) of the three sun planetary is linked to the variator input ring (**319**). In some embodiments, the carrier (**318**) is connected to the housing in IVT mode by applying a brake (**315**). In some embodiments, the sun of the third planetary (**313**) is linked to the carrier of the variator (**321**). In some embodiments, the sun of the third planetary (**313**) is connected to the housing in CVT mode by applying brake (**316**). In some embodiments, in IVT/CVT mode, the sun of the second planetary is connected to the housing by applying brake (**317**), thus letting the variator input ring (**319**) and variator carrier (**321**) be both driven. In some embodiments, this IVT/CVT mode lies in-between the IVT mode and the CVT mode concerning speeds. In some embodiments, the overall ratio is the product of the three sun planetary ratio, the variator ratio and the final drive ratio. In some embodiments, standstill, very low vehicle speeds and reverse are typically achieved by the IVT mode of the variator.

[0031] In some embodiments, the transition between the three modes is simply done by engaging one brake and releasing the others. In some embodiments, this device is able to change continuously its ratio to provide the best ratio achievable for the engine in function of the objectives of consumption or power. In a manual or automatic transmission. In certain instances, in a manual or automatic transmission, only some predetermined and discrete ratios are available and an interruption of the power transmission is needed to shift the ratio. In some embodiments, the only interruption of power in this device is to change modes. In some embodiments, another advantage is that spread is higher than traditional gearboxes by having those three modes, which can improve global efficiency of the vehicle. In some embodiments, the apparatus allows for mode shifting between the continuously variable (CVT) mode, infinitely variable (IVT) mode and the combined IVT/CVT mode with a minimum number of brakes.

[0032] Concept 1 e/

[0033] In an automobile **40**, the CVT **403** is used to replace a traditional transmission and is located between the engine **400** and the differential **402**. In some instances, a torsional damper **401** is introduced between the engine **400** and rav-

igneaux-like planetary **411** as shown on FIG. 6. Configuration 1e/ (FIG. 6) uses a ravigneaux-like planetary (**411**) before going to the variator (**412**). In the Ravigneaux-like planetary, the planets of first plane of gears and of second plane of gears are made of a single piece. In some embodiments, the variator output ring (**420**) is then linked to the final drive (**422**) and differential. In some embodiments, the configuration comprises three brake clutches, one for IVT mode (**413**); one for CVT mode (**414**), and one for an IVT/CVT mode (**415**) where the variator input ring (**419**) and the variator carrier (**421**) are both driven. In some embodiments, the central part of that configuration is the variator described above. In some embodiments, a ball ramp on each side of the variator provides the clamping force necessary to transfer the torque.

[0034] In some embodiments, the carrier (**418**) of the ravigneaux-like planetary is linked to the variator input ring (**419**). In some embodiments, the carrier (**418**) is connected to the housing in IVT mode by applying brake (**413**). In some embodiments, the sun (**416**) of the second plane of gear of the Ravigneaux planetary (**411**) is linked to the carrier of the variator (**421**). In some embodiments, the sun (**416**) is connected to the housing in CVT mode by applying brake (**414**). In some embodiments, in IVT/CVT mode, the ring of the planetary system (**411**) is connected to the housing by applying brake (**415**), thus letting the variator input ring (**419**) and variator carrier (**421**) be both driven. In some embodiments, this IVT/CVT mode lies in-between the IVT mode and the CVT mode concerning speeds. In some embodiments, the overall ratio is the product of the ravigneaux-like planetary ratio, the variator ratio and the final drive ratio. In some embodiments, standstill, very low vehicle speeds and reverse are achieved by the IVT mode of the variator.

[0035] In some embodiments, the transition between the three modes is simply done by engaging one clutch and releasing the other. In some embodiments, this device is able to change continuously its ratio to provide the best ratio achievable for the engine in function of the objectives of consumption or power. In certain instances, in a manual or automatic transmission, only some predetermined and discrete ratios are available and an interruption of the power transmission is needed to shift the ratio. In some embodiments, the only interruption of power in this device is to change modes. In some embodiments, another advantage is that spread is higher than traditional gearboxes by having those three modes, which improves efficiency. In some embodiments, another advantage is that the ravigneaux-like planetary is a compact system. In some embodiments, the apparatus allows for mode shifting between the continuously variable (CVT) mode, infinitely variable (IVT) and the combined IVT/CVT mode with a minimum number of brakes.

[0036] Concept 1f/

[0037] In an automobile **50**, the CVT **503** is used to replace a traditional transmission and is located between the engine **500** and the differential **502**. In some instances, a torsional damper **501** is introduced between the engine **500** and ravigneaux-like planetary **511** as shown on FIG. 7. Configuration 1f/ (FIG. 7) uses a ravigneaux-like planetary (**511**) before going to the variator (**512**). In some embodiments, the variator output ring (**520**) is then linked to the final drive (**522**) and differential. In some embodiments, the configuration comprises three brake clutches, one for IVT mode (**513**); one for CVT mode (**514**), and one for an IVT/CVT mode (**515**) where the variator input ring (**519**) and the variator carrier (**521**) are both driven. In some embodiments, the central part of that

configuration is the variator described above. In some embodiments, a ball ramp on each side of the variator provides the clamping force necessary to transfer the torque.

[0038] In some embodiments, the output (516) sun of the ravigneaux-like planetary (511) is linked to the variator input ring (519). In some embodiments, the output (516) sun is connected to the housing in IVT mode by applying brake (513). In some embodiments, the carrier (518) of that system (511) is then linked to the carrier of the variator. In some embodiments, the carrier (518) is connected to the housing in CVT mode by applying brake (514). In some embodiments, in IVT/CVT mode, the ring (517) of the planetary system (511) is connected to the housing by applying brake (515), thus letting the variator input ring (519) and variator carrier (521) be both driven. In some embodiments, this IVT/CVT mode lies in-between the IVT mode and the CVT mode concerning speeds. In some embodiments, the overall ratio is the product of the ravigneaux-like planetary ratio, the variator ratio and the final drive ratio. In some embodiments, standstill, very low vehicle speeds and reverse are achieved by the IVT mode of the variator.

[0039] In some embodiments, the transition between the three modes is simply done by engaging one brake and releasing the others. In some embodiments, this device is able to change continuously its ratio to provide the best ratio achievable for the engine in function of the objectives of consumption or power. In certain instances, in a manual or automatic transmission, only some predetermined and discrete ratios are available and an interruption of the power transmission is needed to shift the ratio. In some embodiments, the only interruption of power in this device is to change modes. In some embodiments, another advantage is that spread is higher than traditional gearboxes by having those three modes, which improves efficiency. In some embodiments, another advantage is that the ravigneaux-like planetary is a compact system. In some embodiments, the apparatus allows for mode shifting between the continuously variable (CVT) mode, infinitely variable (IVT) and the combined IVT/CVT mode with a minimum number of brakes.

[0040] Concept 1g/

[0041] In an automobile 60, the CVT 603 is used to replace a traditional transmission and is located between the engine 600 and the differential 602. In some instances, a torsional damper 601 is introduced between the engine 600 and a planetary gear 611 as shown on FIG. 8. Configuration 1g/ (FIG. 8) uses a planetary gear set (611) before going to the variator (612). In some embodiments, the variator output is linked to an additional planetary (613). In some embodiments, this planetary (613) is locked to turn with a 1:1 ratio by applying the clutch (616) to lock its sun and planet carrier together. In some embodiments, a speed increase is achieved by having more spread by applying the overdrive brake (617) to lock the sun of the planetary to the ground. In some embodiments, the ring of this planetary is then linked to the final drive and differential. In some embodiments, the second ring of the variator is linked to the planet carrier of the third planetary. In some embodiments, the configuration comprises three brakes, one for IVT mode (615) and one for CVT mode (614) and one for applying an overdrive ratio (617). In some embodiments, the configuration comprises a clutch (616) to bypass the overdrive planetary (613) by putting it in a 1:1 ratio. In some embodiments, the central part of that configuration comprises the variator described above. In some

embodiments, a ball ramp on each side of the variator provides the clamping force necessary to transfer the torque.

[0042] In some embodiments, the ring of the input planetary is linked to the variator input ring. In some embodiments, the ring of the input planetary is connected to the housing in IVT mode by applying the IVT brake (615). In some embodiments, the carrier of the input planetary is connected to the housing in CVT mode by applying the CVT brake (614). In some embodiments, the carrier of the input planetary is linked to the carrier of the variator. In some embodiments, the overall ratio is typically the product of the input planetary ratio, the variator ratio, the output planetary (613) ratio and the final drive ratio. In some embodiments, standstill, very low vehicle speeds and reverse is achieved by the IVT mode of the variator.

[0043] In some embodiments, the transition between the two modes (CVT and IVT) is simply done by releasing one brake and closing the other. Furthermore, the clutch (616) of the output planetary might be used to select a ratio 1:1 in the output planetary. And the Overdrive brake might be selected to provide an overdrive ratio. At any moment only one of these overdrive brake and direct drive clutch has to be engaged. The transition between these two additional ratios is simply done by releasing one and engaging the other. In some embodiments, this device is able to change continuously its ratio to provide the best ratio achievable for the engine in function of the objectives of consumption or power. In certain instances, in a manual or automatic transmission, only some predetermined and discrete ratios are available and an interruption of the power transmission is needed to shift the ratio. In certain instances, the only interruption of power in this device is to change modes. Other advantages include, but are not limited to: a small final drive (in one step, not needing a countershaft) and cost effectiveness of the system. In some embodiments, spread is higher than traditional gearboxes by adding the third planetary, which improves global efficiency of the vehicle. In some embodiments, the apparatus allows for mode shifting between the continuously variable (CVT) mode and infinitely variable (IVT) mode with a minimum number of brakes.

[0044] Embodiments of the variable transmission described herein or that would be obvious to one of skill in the art upon reading the disclosure herein are contemplated for use in a variety of vehicle drivelines. For non-limiting example, the variable transmissions disclosed herein may be used in bicycles, mopeds, scooters, motorcycles, automobiles, electric automobiles, trucks, sport utility vehicles (SUV's), lawn mowers, tractors, harvesters, agricultural machinery, all-terrain vehicles (ATV's), jet skis, personal watercraft vehicles, airplanes, trains, helicopters, buses, forklifts, golf carts, motorships, steam powered ships, submarines, space craft, or other vehicles that employ a transmission.

[0045] While the figures and description herein are directed to ball-type variators (CVTs), alternate embodiments are contemplated another version of a variator (CVT), such as a Variable-diameter pulley (VDP) or Reeves drive, a toroidal or roller-based CVT (Extroid CVT), a Magnetic CVT or mCVT, Ratcheting CVT, Hydrostatic CVTs, Naudic Incremental CVT (iCVT), Cone CVTs, Radial roller CVT, Planetary CVT, or any other version CVT.

[0046] While preferred embodiments of the present invention have been shown and described herein, it will be obvious to those skilled in the art that such embodiments are provided

by way of example only. Numerous variations, changes, and substitutions will now occur to those skilled in the art without departing from the invention. It should be understood that various alternatives to the embodiments of the invention described herein may be employed in practicing the invention. It is intended that the following claims define the scope of the invention and that methods and structures within the scope of these claims and their equivalents be covered thereby.

What is claimed is:

1-29. (canceled)

30. An apparatus for power transmission comprising:

a power input shaft;

a planetary gear set mechanically coupled to the power input shaft;

a variator mechanically coupled to the gear set; and

three brakes for switching among a plurality of operational modes of the power transmission apparatus.

31. The power transmission apparatus of claim **30**, wherein a planetary gear set is coupled to the output of the variator and to the final reduction.

32. The power transmission apparatus of claim **30**, wherein the three brakes are configured to be selectively engaged or released to switch among the modes of the power transmission apparatus.

33. The power transmission apparatus of claim **30**, wherein the variator is coupled to a planet of the planetary gear set.

34. The power transmission apparatus of claim **32**, wherein the first brake engages said IVT mode, said second brake engages said CVT mode and the third brake is for applying an overdrive ratio.

* * * * *