

J. H. NELLIS.
DICE THROWER.

No. 524,265.

Patented Aug. 7, 1894.

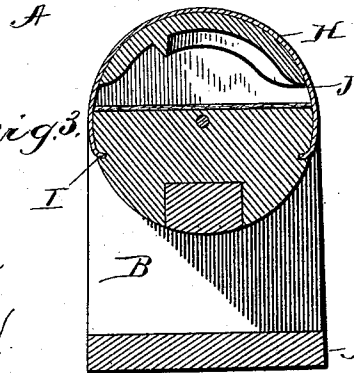
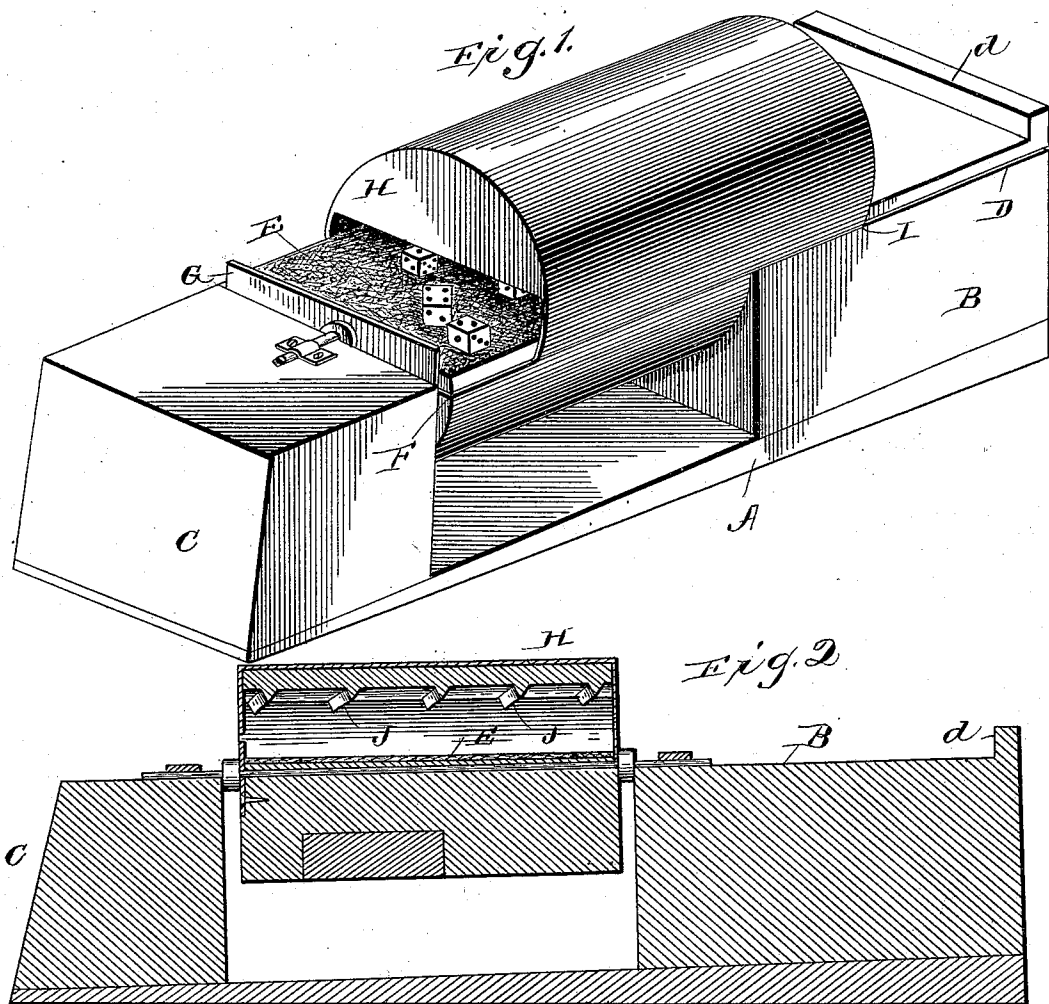

witnesses
J. M. Fowler Jr
Poland A. Fitzgerald,

Inventor
J. H. Nellis

By *Lehmann, Patterson & Herold*
 Attorneys

J. H. NELLIS.
DICE THROWER.

No. 524,265.

Patented Aug. 7, 1894.

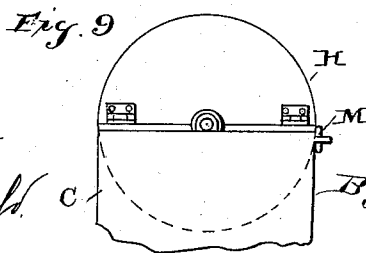
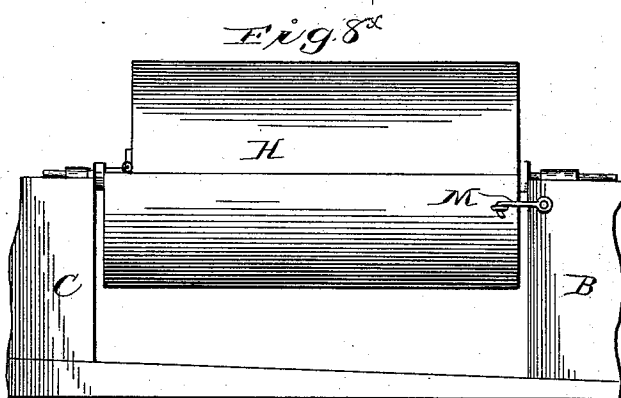
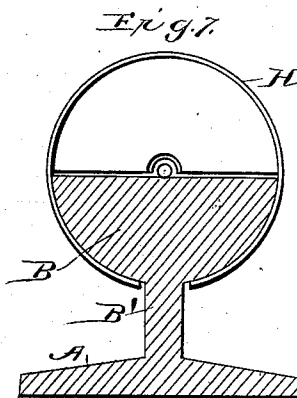
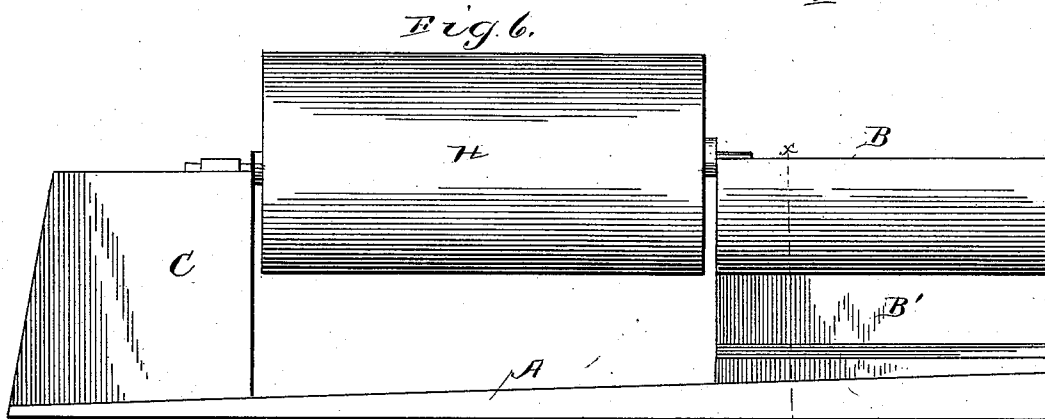
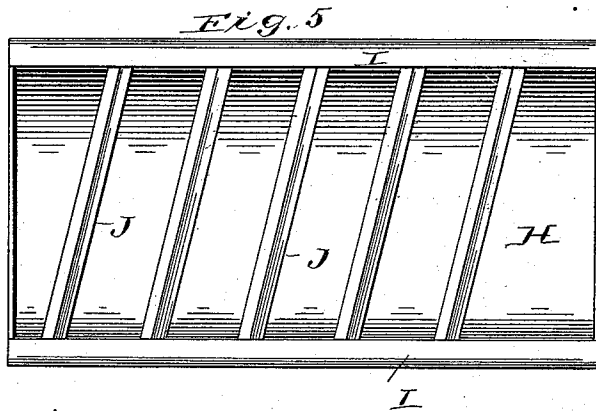
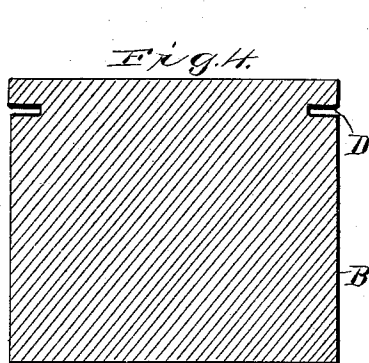

witnesses
J. M. Fowler Jr
Roland C. Fitzgerald

Inventor
J. H. Nellis
 By *Lehmann Patterson & Washit*
 Attorneys.

UNITED STATES PATENT OFFICE.

JACOB H. NELLIS, OF CANAJOHARIE, NEW YORK.

DICE-THROWER.

SPECIFICATION forming part of Letters Patent No. 524,265, dated August 7, 1894.

Application filed July 19, 1893. Serial No. 480,938. (No model.)

To all whom it may concern:

Be it known that I, JACOB H. NELLIS, of Canajoharie, in the county of Montgomery and State of New York, have invented certain new and useful Improvements in Dice-Throwers; and I do hereby declare the following to be a full, clear, and exact description of the invention, such as will enable others skilled in the art to which it pertains to make and use it, reference being had to the accompanying drawings, which form part of this specification.

My invention relates to an improvement in dice throwers, and it consists in certain novel features of construction hereinafter fully described and especially referred to in the claims.

The object of my invention is to provide an improved device for effectually throwing and mixing dice in a quiet and effective manner, and also to provide such a mixing device or thrower as will preclude the use of loaded dice.

Referring to the accompanying drawings: Figure 1, is a perspective view of my improved dice thrower. Fig. 2, is a longitudinal sectional view of the same, the cup being closed over its revoluble base. Fig. 3, is a cross sectional view of the thrower. Fig. 4, is a similar view of the base portion upon which the cup slides when open. Fig. 5, is a bottom plan view of the cup. Figs. 6 and 8, are side elevations of throwers of modified forms. Fig. 7, is a cross sectional view on line $x-x$, of Fig. 6. Fig. 9 is an end view of Fig. 8.

A designates an inclined support and resting upon its higher end is the base portion B, and at its opposite end the corresponding portion C. The opposite sides of base B are grooved longitudinally near their top edges as shown at D.

E is a semi-cylindrical and revoluble mixing table journaled between base portions B and C, and which is also grooved upon its opposite sides as shown at F, which grooves are in line with grooves D when the mixing table is in its normal position. The lower end of the table is provided with the projecting strip G, for the purpose of preventing the dice from escaping at that point and also for holding the dice cup presently to be explained from longitudinal movement.

H is the semi-circular thrower or cup having its edges turned inward, as at I, which edges move in grooves D and F, so that the said cup may be adjusted, so as to completely cover the mixing table, or it may be pushed back over base portion B, and yet retain a sufficient hold on the mixing table to prevent the same from turning while in this position.

The interior of the cup is preferably formed with irregular serrations as shown at J in order to more effectually turn and mix the dice. The said cup as well as the table, is padded so that the device is practically noiseless in its operation. The lower end of the cup strikes the ledge G, and is thus held from moving off that end of the table.

In operation the dice are placed upon the table and the cup adjusted thereover, so that they cannot be thrown off and then the same is revolved several times, during which operation the dice are most effectually mixed or turned, the operation being entirely mechanical. The cup is then moved back as before described, and the dice exposed to view and the result of the throwing ascertained. The thrower is preferably made inclined, as here shown, so as to work the dice downward toward the lower end of the mixer and thus counteract the tendency to scatter all over the table when the device is being brought to a standstill.

In the construction illustrated in Fig. 6, base B is reduced to form a narrow neck B', while the cup almost encircles the mixing table, the distance between its longitudinal edges being only such as to enable it to pass upon neck B', as will be readily understood.

In the modification shown in Fig. 8, the cup which may be of any preferred construction, is hinged to the mixing table at one end, while its opposite end may be bound down thereto in any preferred manner while in operation. In this construction I provide a catch M extending from base portion B, for the purpose of engaging the movable table and holding it from vibrating while the dice are being inspected, and in fact at all times when the dice are not in actual operation.

Dice throwers constructed as herein shown and described accomplish the desired end by means of an operation nearly mechanical, and

which at the same time precludes the use of loaded dice, as they would not readily turn about in the mixer and would therefore be easily detected.

5 Having thus fully described my invention, what I claim, and desire to secure by Letters Patent, is—

10 1. An improved dice thrower comprising a support, a movable table, and a cover therefor adapted to be moved into engagement with the support, thus holding the table in a fixed position and exhibiting a portion of the table surface, substantially as shown and described.

15 2. An improved dice thrower comprising a support, a movable table in line therewith, and a cover for the table adapted to be moved longitudinally so as to engage both the table and support, thus holding the former in a fixed position and exhibiting a portion of its surface, substantially as shown and described.

20 3. An improved dice thrower comprising a support, a table extending at an incline therefrom and a cover for the table adapted to move backward on the support, thus holding

the table in a fixed position and exhibiting a portion of its surface to which the dice have worked owing to the incline of the table, substantially as shown and described.

4. An improved dice thrower comprising a 30 base grooved longitudinally upon its opposite sides, a revoluble mixing table, longitudinal grooves thereon which are normally in line with the grooves of the base, and a mixing cup forming a cover for the table which is 35 adapted to be guided in its longitudinal movement by said grooves, substantially as shown and described.

5. An improved dice thrower comprising a table revoluble on a longitudinal axis, and a 40 cover for the table having transverse ridges on its interior for the purpose, substantially as specified.

In testimony whereof I affix my signature in presence of two witnesses.

JACOB H. NELLIS.

Witnesses:

N. S. BRUMLEY,
J. H. COOK.