

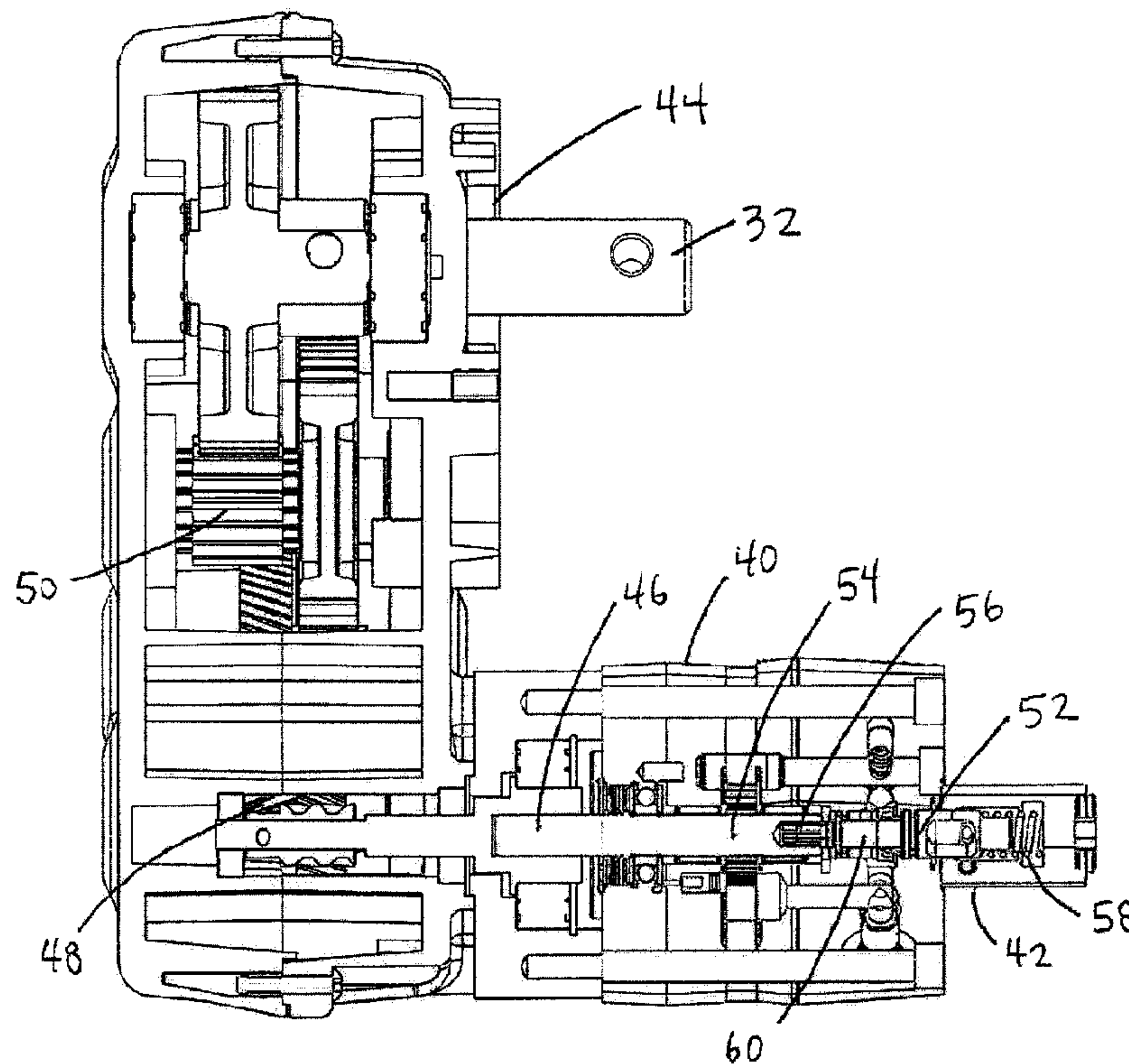

(22) **Date de dépôt/Filing Date:** 2012/01/16  
 (41) **Mise à la disp. pub./Open to Public Insp.:** 2012/07/17  
 (45) **Date de délivrance/Issue Date:** 2019/09/17  
 (30) **Priorité/Priority:** 2011/01/17 (US13/007,819)

(51) **Cl.Int./Int.Cl.** *B60P 7/04* (2006.01),  
*B60J 7/08* (2006.01), *B61D 39/00* (2006.01)  
 (72) **Inventeur/Inventor:**  
SEARFOSS, TIMOTHY K., US  
 (73) **Propriétaire/Owner:**  
ROLL-RITE, LLC, US  
 (74) **Agent:** KERR & NADEAU

(54) **Titre :** ENSEMBLE MOTEUR DE FREIN A COMMANDE HYDRAULIQUE POUR SYSTEME DE RECOUVREMENT D'UN CAMION  
 (54) **Title:** HYDRAULIC BRAKE MOTOR ASSEMBLY FOR TRUCK COVER SYSTEM



(57) **Abrégé/Abstract:**

A hydraulic brake gear motor with a brake mechanism to operate a roll tarp for use with an open top container of a trailer or rail car. A motor-driven rollable cover is attached to and wrappable about a reel to selectively cover contents of the container. The hydraulic driven gear motor operates with a brake mechanism to lock and hold a position of the motor. A secondary brake mechanism may include a hydraulic piston that selectively engages a holding brake with a hex connector. An efficient transmission having rolling gears can be operated by the hydraulic motor with the brake mechanism. The motor and brake mechanism are preferably hydraulically operated with an existing system of the trailer or rail car.

135912-00023

Abstract

A hydraulic brake gear motor with a brake mechanism to operate a roll tarp for use with an open top container of a trailer or rail car. A motor-driven rollable cover is attached to and wrappable about a reel to selectively cover contents of the container. The hydraulic driven gear motor operates with a brake mechanism to lock and hold a position of the motor. A secondary brake mechanism may include a hydraulic piston that selectively engages a holding brake with a hex connector. An efficient transmission having rolling gears can be operated by the hydraulic motor with the brake mechanism. The motor and brake mechanism are preferably hydraulically operated with an existing system of the trailer or rail car.

Hydraulic Brake Motor Assembly for Truck Cover System

Field of the Disclosure

**[0001]** This disclosure relates to a hydraulic driven gear motor with a secondary holding device, such as for tarp systems for trailers or railcars. More specifically, the disclosure relates to a hydraulic brake motor used with a transmission having high efficiency gears that are not self-braking.

Background

**[0002]** Trucks and cabs pull trailers that often have tarp systems. Similarly, rail cars may have open top container cars for which tarp systems may be used. Tarps are well known for covering contents of a container of the trailers and railcars during transport. Roll tarps often include a tarp attached on an axle, reel or roller and to a side of a container. Tarp systems are automated to cover trailers while transporting contents of the container. But size limitations, weight limits, efficiency, and output of motor and transmission must be maximized for tarp systems.

**[0003]** Apparatus have been devised for covering a truck load. Some such apparatus include an electric motor for selectively winding a flexible cover. U.S. Pat. No. 5,031,955 provides a truck cover that may be motor-operated from the cab of a truck to extend the cover from a winding assembly proximate the front of the truck bed and forward the rear of the truck bed. It discloses a direct drive spool winding system with an automatic self-brake feature with the 90 degree relationship of the worm gear with respect to the drive bolt threads.

**[0004]** Automated systems that cover the truck bed from side to side are known. For instance, U.S. Pat. No. 5,328,228 shows a cover for truck bed and cargo. Similarly, U.S. Pat. No. 5,924,758 shows a roll assist mechanism for tarp systems. U.S. Pat. No. 6,206,449 shows a side-to-side truck cover system including a pair of arms, each of which includes a base and an extension.

**[0005]** Later Roll-Rite patents protect other aspects of a motor and knuckle arm assembly to unroll to open and to roll to close the tarp to cover the contents of a container of a truck or trailer.

**[0006]** U.S. Patent Nos. 7,726,720 and 6,916,060 show a motor 30 mounted on the distal end

of the extension 18. A rotatable reel 32 extends from the motor 30, and that is operatively connected to one end of the cover 12 so as to function as a take-up spool. The motor 30 is preferably provided with a brake, which allows, among other things, for the apparatus 10 to remain in the stowed or uncovered position. When the brake is released, the base 14 swings toward a side of the trailer or truck bed. The motor 30 may be powered, from within or without the cab of the truck, to facilitate operation. Further details of one embodiment of the motor are taught by U.S. Pat. No. 5,829,819. In this way, the cover 12 is pulled off of the reel 32 and extended over the trailer or truck bed. The motor 30 can be reversed to drive the reel 32 and retract the cover 12 against the tension force of the springs to uncover the load bed.

**[0007]** Patent 5,829,819 discloses a direct-drive actuator assembly that actuates a tarp spool for a truck bed tarp system. The direct-drive actuator assembly includes a transmission housing adapted for mounting to the tarp housing. An output shaft extends from the transmission housing for driving the tarp spool. An input shaft is also positioned at least partially within the transmission housing. An electric motor is operatively connected to the input shaft for actuating the tarp spool. The spur gear arrangement is not self-braking so a brake arrangement is used with the DC motor. A brake, such as a spring-loaded, power release type, is operatively connected to the electric motor for automatically braking the motor when the electric motor is turned off. A cover is provided for enclosing the stacked brake and electric motor against the transmission housing.

**[0008]** Automatic motor-operated solutions for tarp operation are known in the art. Electric motors are used with worm gears for roll tarp systems. In typical powered tarp systems, an electric motor may be used in conjunction with worm gears, which can be self-braking. Worm gears are inefficient. Patent 5,829,819 discloses a series of rotatable transmission spur gears in a system with a secondary brake.

**[0009]** Trucks and trailers often have hydraulic systems to operate hydraulic components or other systems of the truck or trailer. Hydraulic systems have not been integrated with motors for roll tarp systems.

**[00010]** A higher efficiency, enhanced powered system in a compact, lightweight package is desirable.

135912-00023

Summary

- [00011]** The present disclosure provides hydraulic driven gear motors with a secondary holding device. This system is well suited for a roll tarp system with a motor and transmission combination enhanced for certain uses, but may include some conventional components, such as a knuckle arm assembly, to help operate the tarp system.
- [00012]** Both electric and hydraulic driven gear motors need to have a holding device, such as a brake mechanism, with high efficiency spur gears in the transmission. Currently, drives may have worm gears, which are self-braking so an ordinary motor would run them. Using high efficiency gears, such as spur gears, can get more power output without making them extremely large, heavy, and expensive. The spur gear system does not require bleeding of oil or extensive efforts to enhance lubricity. A good worm gear set (such as with teeth cut on an angle to connect non-parallel shafts) may be 30% efficient, compared to a spur gear set (as a toothed wheel with radial teeth parallel to the axis) at 99% efficiency. The spur gear set is not self braking, so a holding device to lock and hold the motor position is required. The system thus needs a secondary brake or stop.
- [00013]** The independent brake mechanism allows the transmission system to use spur gears. The disclosed system is not limited by the type of brake mechanism. A mechanical holding device is preferred, such as a hexagon mechanical brake in a receiver with a hex connector that can lock and hold the motor position. The holding device mechanism can also preferably be hydraulic.
- [00014]** The disclosed system substitutes a hydraulic brake gear motor for an existing electric motor. The hydraulic brake motor can operate using existing hydraulics of the truck or trailer etc. The hydraulic system of the truck or trailer can effectively operate the hydraulic motor and a brake mechanism. With a small size, the hydraulic brake motor is adapted to be used with an efficient transmission, such as spur gear systems, with suitable characteristics for a roll tarp.
- [00015]** The combination of the hydraulic brake motor and the transmission provides a high efficiency, higher output power in a small, light package. The system is compact and light, but is also highly efficient with enhanced power output.

Brief Description of the Drawings

**[00016]** The above-mentioned and other features of this disclosure and the manner of obtaining them will become more apparent, and the disclosure itself will be best understood by reference to the following descriptions of systems taken in conjunction with the accompanying figures, which are given as non-limiting examples only, in which:

Figure 1A shows a prior art system from U.S. Patent 6,916,060;

Figure 1B shows a truck with a roll tarp system;

Figure 2 shows a perspective view of a transmission housing, an output to reel, a motor and a brake mechanism;

Figure 3 shows a partial cut-away view of a hydraulic motor with a brake mechanism with a transmission for operating a tarp; and

Figure 4 shows a motor with a different transmission.

**[00017]** The exemplifications set out herein illustrate embodiments of the disclosure that are not to be construed as limiting the scope of the disclosure in any manner. Additional features of the present disclosure will become apparent to those skilled in the art upon consideration of the following detailed description of illustrative embodiments exemplifying the best mode of carrying out the disclosure as presently perceived.

Detailed Description

**[00018]** While the present disclosure may be susceptible to embodiments in different forms, the figures show, and herein described in detail, embodiments with the understanding that the present descriptions are to be considered exemplifications of the principles of the disclosure and are not intended to be exhaustive or to limit the disclosure to the details of construction and the arrangements of components set forth in the following description or shown in the figures.

**[00019]** Figure 1A shows a conventional truck 10 with a prior art tarp system with an arm assembly comprising a base 14, an intermediate segment 16 and an extension 18 for a flexible tarp or cover of a truck. The tarp as shown should be wound or wrapped on a reel 32 in an uncovered position. The base 14 is mounted to the truck 10 at a base plate 20 proximate a top of a cab 22 of the truck 10. A motor 30 is mounted on the distal end of the extension 18. A rotatable reel 32 extends from the motor 30, and is operatively connected to one end of the

cover so as to function as a take-up spool. The other end of the cover can be fixed at one or more points along a line below the top of one side of the truck 10. The prior art motor 30 is preferably provided with a brake that allows, among other things, for the apparatus to remain in the uncovered position shown in Figure 1A. When the brake is released, the base 14 swings toward the right side of the truck bed until it engages the stop 26. The motor 30 may be powered, from within or out of the cab of the truck 10, to facilitate this operation. This is one example of a side-to-side tarp system compatible with the present enhancements.

**[00020]** This system is well suited for a roll tarp system with an improved motor and transmission combination of a rollable cover for use with an open top container of a trailer or rail car.

**[00021]** Figure 1B shows a truck 10 with a tarp system with a motor 40 of the present invention. The presently disclosed motor 40 is a hydraulic motor with a separate brake mechanism 42 that collectively operate with a different transmission 44 used with a reel 32 (or similar axle shaft for a tarp) as part of a tarp system. The system is designed to brake, lock and hold the position of the motor 40 when not operating. A hydraulic driven gear motor 40 is preferably mounted on a distal end of an arm assembly 19 for a side-to-side tarp system or a headboard of a container.

#### Motor

**[00022]** The hydraulic motor 40 may have a drive shaft 46 as input to the transmission 44. A motor-driven shaft 46 may extend from the motor 40 into the transmission 44. The hydraulic motor 40 drives the shaft 46 for driving transmission gears 48 and 50 and the output shaft 32 for moving, such as rolling, a cover, such as a tarp. The hydraulic motor 40 may weigh less than ten pounds, and preferably less than four pounds including the brake mechanism 42.

**[00023]** A hydraulic brake gear motor does not require electric power. The hydraulic brake motor 40 can operate using existing hydraulics of the truck or trailer etc. The hydraulic system of the truck or trailer can operate the hydraulic motor 40 and brake mechanism 42.

**[00024]** The hydraulic motor 40 needs to have a brake mechanism 42 in conjunction with high efficiency gears 48 and 50, such as spur gears (including helical gears), in the transmission 44. Not being self-braking, an ordinary motor would not properly run the transmission 44 so a secondary brake mechanism 42 is required to lock and hold the motor position.

**[00025]** With a small size, the hydraulic motor 40 is adapted to be used with an enhanced

transmission 44, such as spur gear systems, with suitable characteristics for a roll tarp. The transmission 44 uses high efficiency gears, such as spur gears, to get more power output without making the gears extremely large, heavy, and expensive.

Brake Mechanism

- [00026]** Not being self-braking, the brake mechanism 42 is used in conjunction with the hydraulic motor 40 for automatic braking to lock and hold a position of the motor 40.
- [00027]** A preferred brake mechanism 42 is a mechanical holding brake, such as shown with a hexagon mechanical brake 52 in a receiver 54 with a hex connector 56 that can lock and hold the motor position. As such, a hex connector 56 can mechanically lock and hold the motor position and the corresponding gears. i.e. 48 and 50, and thus the reel 32 operating a roll cover. The hex connector 56 secures in a receiver 54, such as a recess as a female hex, to prevent rotation of the drive shaft 46. Further, a resilient spring 58 can be applied on the brake 52 as a spring-applied brake that may be overcome with a hydraulic piston 60.
- [00028]** The brake mechanism 42 may include a hydraulic piston 60 that selectively engages a holding brake 52 with a hex connector 56 that mechanically cooperates with a receiver 54 in the drive shaft 46 to lock and hold the position of the hydraulic driven gear motor 40.
- [00029]** The brake mechanism 42 can be a spring-applied, hydraulic-released brake to facilitate automatic locking of the hydraulic motor 40. The brake mechanism 42 can also preferably be hydraulically operated in conjunction with the hydraulic motor 40.
- [00030]** The hydraulics can be used to operate the hydraulic motor 40 and can simultaneously disengage a hydraulic piston 60 to disengage a holding brake. The preferred brake 52 automatically brakes the hydraulic motor 40 when the hydraulics are not operating the motor 40.
- [00031]** When the hydraulic motor 40 is not energized, the spring 58 causes the hex connector 56 to engage the drive shaft 46 to lock the drive shaft from rotating. When the hydraulic motor 40 is engaged, the hydraulic piston 60 is also engaged keeping the hex connector 56 disassociated with the drive shaft 46 by overcoming the spring force.
- [00032]** In operation, the motor 40 stops when a control valve is closed, which stops the motor 40, and then the engaging parts, such as 54 and 56, engage. A male hex connector 56 slides into a receiver 54, such as female hex, thus preventing the motor from turning until the male hex connector 56 is disengaged.

**[00033]** The system is not limited by the type of brake mechanism. U.S. Patent 5,829,819 discloses a friction brake with a friction disc to lock a hub and accordingly preventing rotation of a drive shaft. This could be an alternative to a mechanical lock and hold brake.

Transmission

**[00034]** The hydraulic motor 40 is used in conjunction with rolling gears 50, preferably a spur gear set. The drive shaft 46 rotatably drives transmission gears 50. A spur gear has a cylinder or disk with the teeth projecting radially with the edge of the teeth straight and aligned parallel to the axis of rotation. These gears can be meshed together when they are fitted to parallel axles. Tooth contact is primarily rolling with sliding occurring during engagement and disengagement. This may be 99% efficient.

**[00035]** The multiple gears allow the size and weight of the transmission to be minimized. For example, the transmission in Figure 3 has eight gears and the transmission in Figure 4 has six gears in a confined space.

**[00036]** The output shaft 32 may extend from the transmission to directly drive a reel, axle or roller to operate a roll tarp.

**[00037]** An enhanced motor, brake mechanism, and transmission combination can be used in conjunction with a variety of container covers and side-to-side knuckle arm assemblies, such as on a front side of the reel 32 with a roller or reel as a means to actuate a roll tarp. The arm assembly can allow the cover to be wound upon the reel 32 that moves in an opening direction or in reverse to unwind to close the tarp. Several prior art systems are described, including a front-to-back system, that may use a spur gear system.

**[00038]** A substitution of a hydraulic brake motor and enhanced transmission does not affect other aspects of the existing tarp structures. The hydraulic driven gear motor with a brake mechanism can be interchanged with electric motors. The size and weight are another benefit of the enhanced motor, brake mechanism, and transmission combination.

**[00039]** This disclosure has been described as having exemplary embodiments and is intended to cover any variations, uses, or adaptations using its general principles. It is envisioned that those skilled in the art may devise various modifications and equivalents without departing from the spirit and scope of the disclosure as recited in the following claims. Further, this disclosure is intended to cover such variations from the present disclosure as come within the known or customary practice within the art to which it pertains.

135912-00023

Claims

What is claimed is:

1. Intended for use with an open top container of a trailer or rail car, a tarp system with a cover movable between an opened position and a closed position, wherein the cover is attached to and wrappable about a reel, the tarp system comprising:
  - a rollable cover adapted to cover contents of the container;
  - a moveable arm operably attached to a portion of the container;
  - a hydraulic driven gear motor with a hydraulically-operated brake mechanism to lock and hold a position of the motor, the hydraulically-operated brake mechanism is a mechanical lock and hold brake including a hydraulic piston; and
  - a transmission having a rolling gear set rotated by the motor and with an output for driving the reel to operate the cover;wherein a hydraulic system of the trailer or rail car operates the hydraulic driven gear motor and the hydraulically-operated brake mechanism.
2. The tarp system of claim 1 wherein the hydraulic driven gear motor is mounted on a distal end of an arm assembly including the moveable arm.
3. The tarp system of claim 1 wherein the rolling gear set includes a spur gear.
4. The tarp system of claim 1 wherein the brake mechanism includes the hydraulic piston that selectively engages the hold brake with a hex connector that mechanically cooperates with a receiver in a drive shaft to lock and hold the position of the hydraulic driven gear motor.
5. Intended for use with an open top container of a trailer or rail car, a tarp system with a cover movable between an opened position and a closed position, wherein the cover is attached to and wrappable about a reel, the tarp system comprising:
  - a rollable cover adapted to cover contents of the container;

a hydraulic driven gear motor with a hydraulically-operated brake mechanism to lock and hold a position of the motor;

the hydraulically-operated brake mechanism is a mechanical lock and hold brake including a hydraulic piston that selectively engages the hold brake with a hex connector that mechanically cooperates with a receiver to lock and hold the hydraulic driven gear motor; and

a transmission having a gear set rotated by the motor and with an output for driving the reel to operate the cover;

wherein a hydraulic system of the trailer or rail car operates the hydraulic driven gear motor and the hydraulically-operated brake mechanism.

6. The tarp system of claim 5 wherein the gear set includes spur gears.

7. The tarp system of claim 5 wherein the motor and brake mechanism weigh less than four pounds.

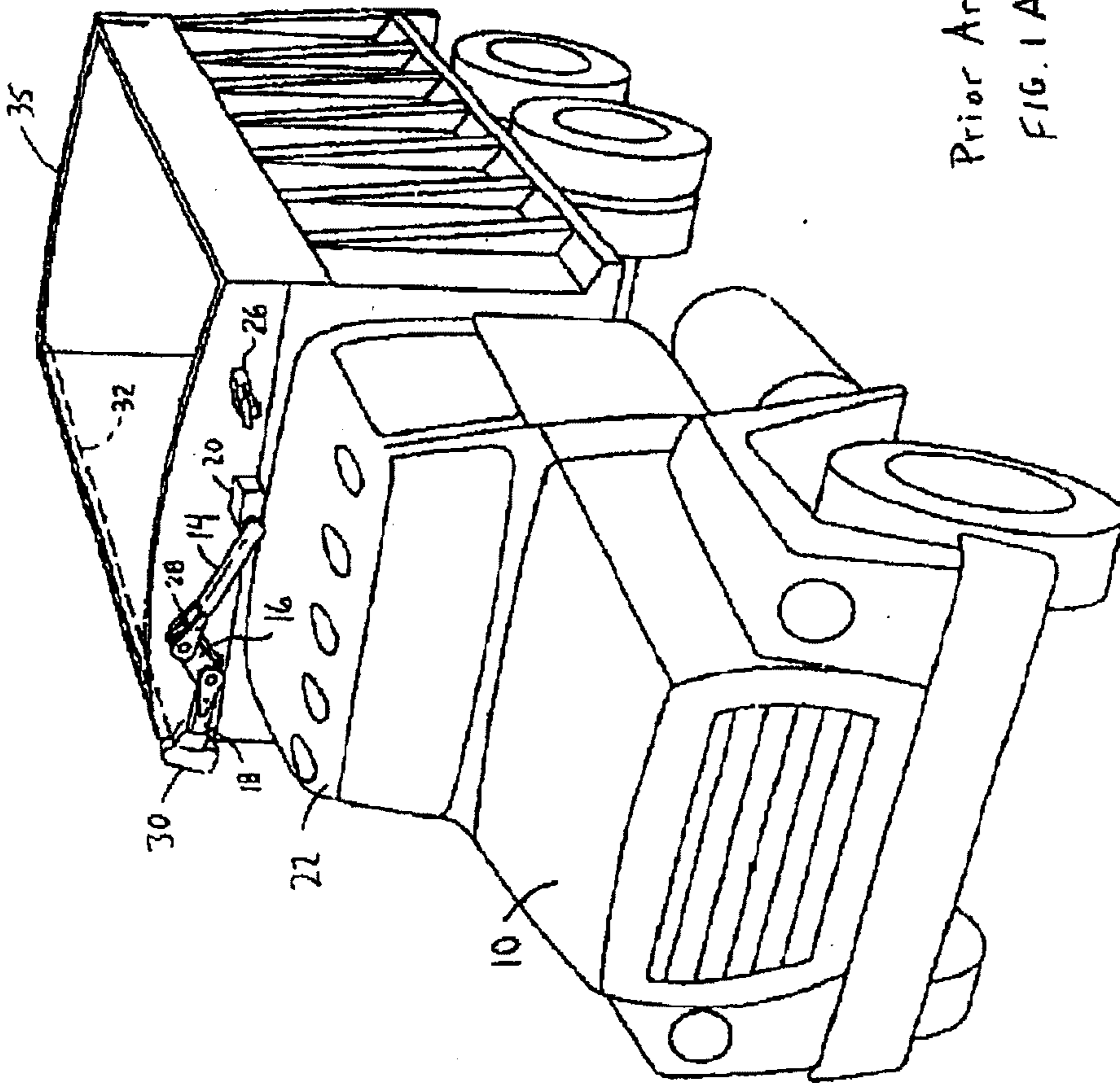

Prior Art  
FIG. 1A

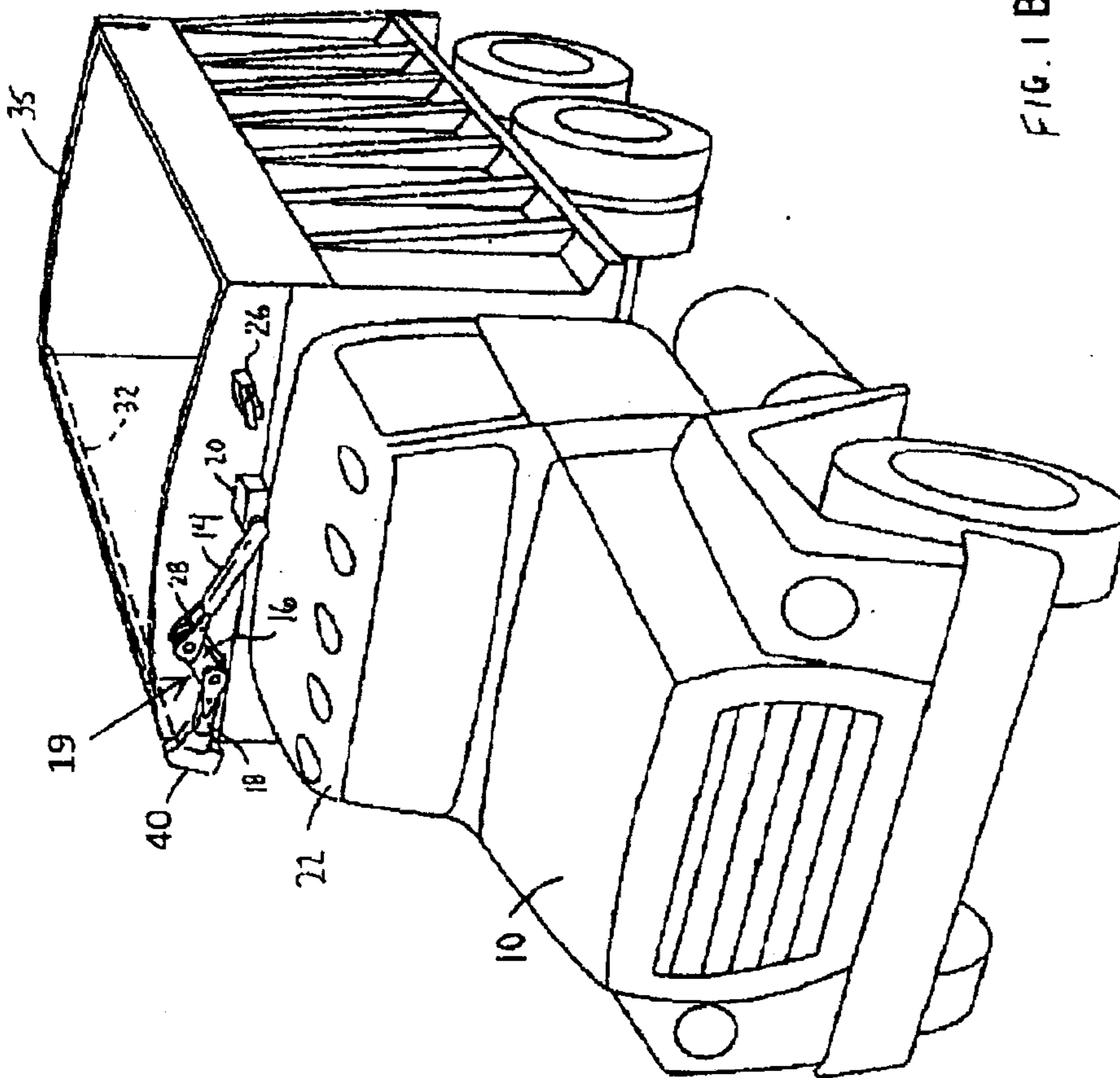

FIG. 1 B

REPLACEMENT SHEET

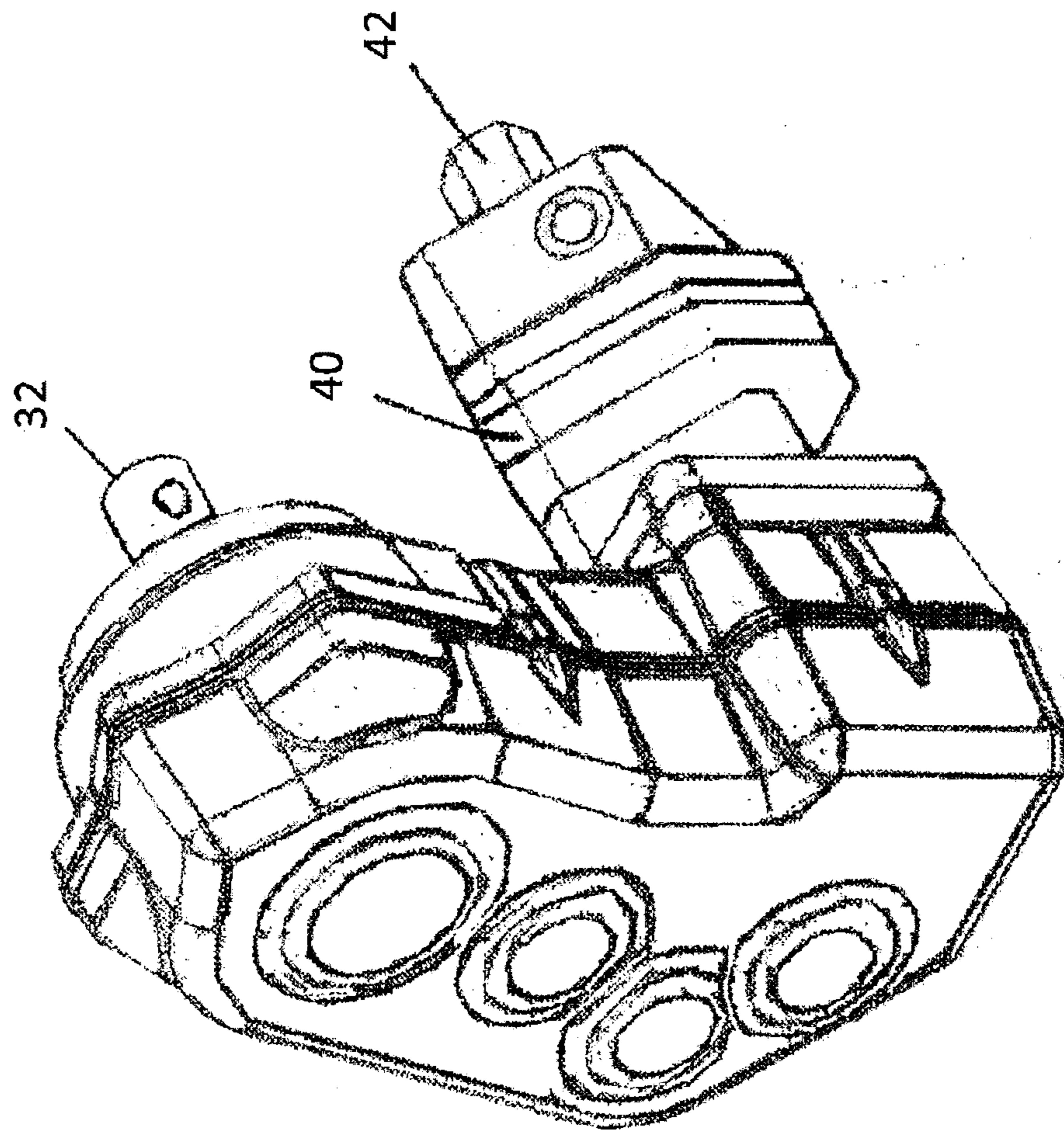

Fig. 2

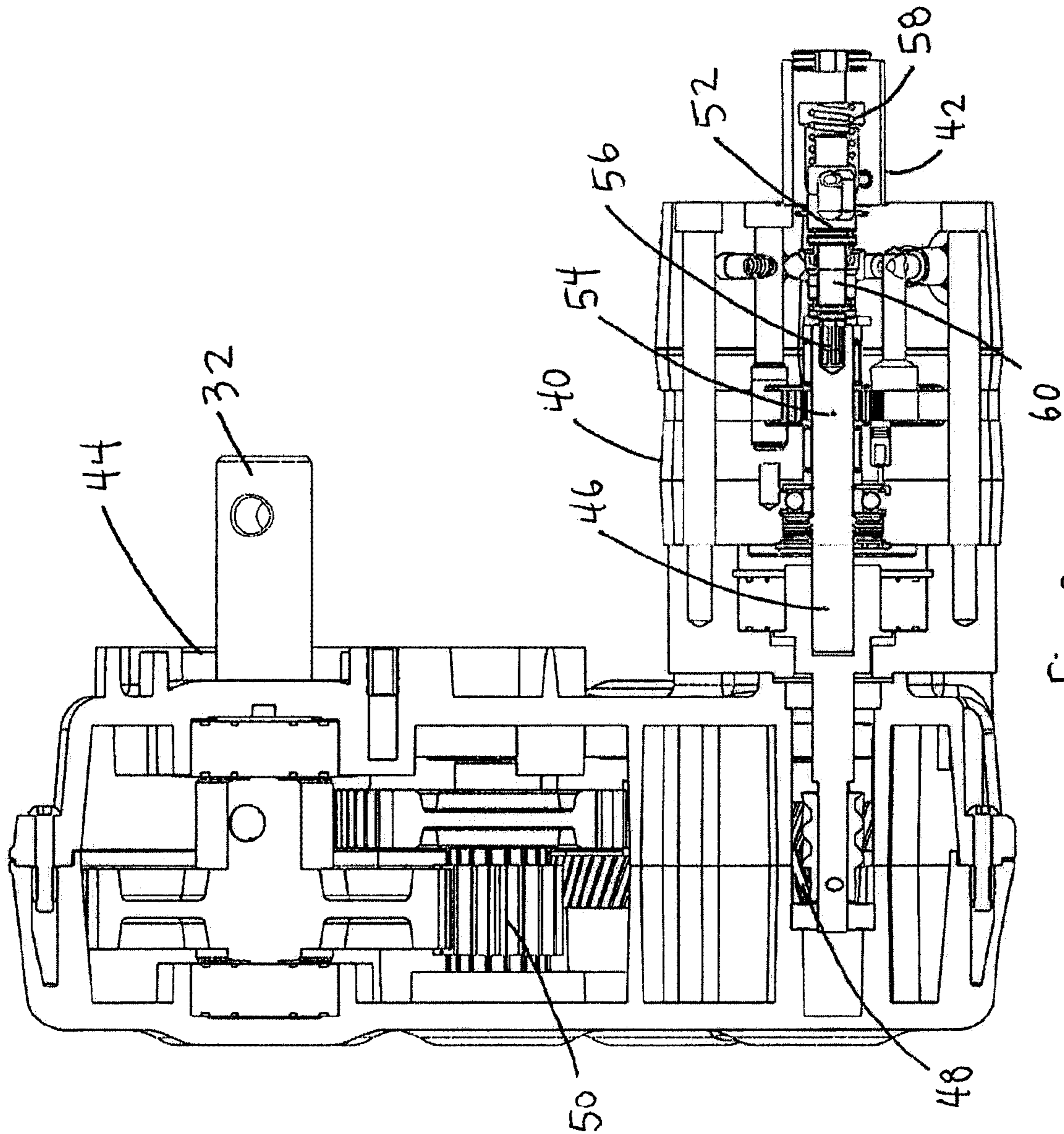

Fig. 3

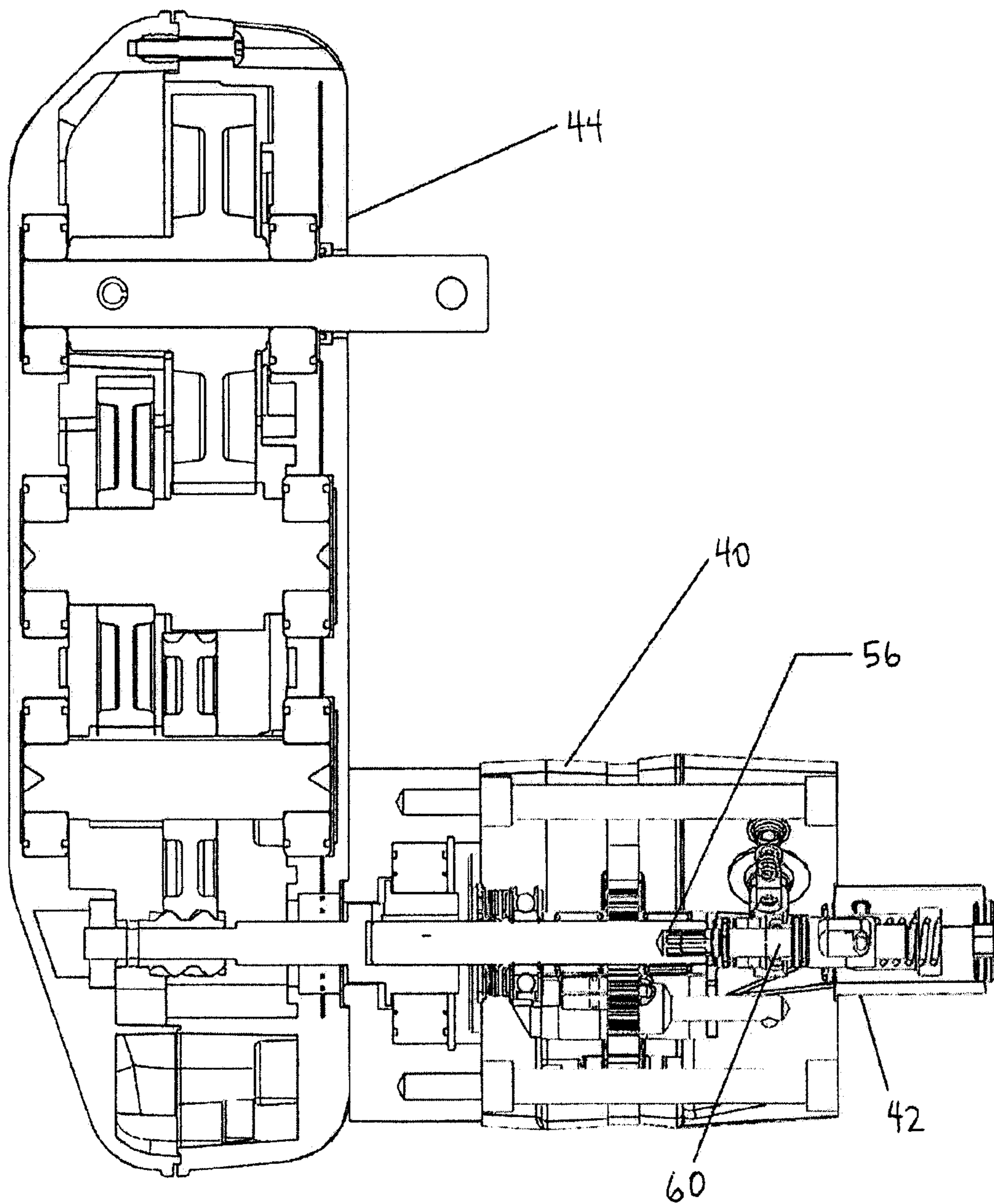

Fig. 4  
4/4

