

(19) World Intellectual Property
Organization
International Bureau



(43) International Publication Date
24 February 2005 (24.02.2005)

PCT

(10) International Publication Number
WO 2005/016765 A2

- (51) International Patent Classification⁷: **B65D**
- (21) International Application Number:
PCT/US2004/025779
- (22) International Filing Date: 10 August 2004 (10.08.2004)
- (25) Filing Language: English
- (26) Publication Language: English
- (30) Priority Data:
10/640,900 14 August 2003 (14.08.2003) US
- (71) Applicant (for all designated States except US): **EVER-THERE CARRIERS, LLC** [US/US]; 509 Greenbriar Drive, North Augusta, South Carolina 29860 (US).
- (72) Inventors; and
- (75) Inventors/Applicants (for US only): **THREET, Stephen W.** [US/US]; 509 Greenbriar Drive, North Augusta, South Carolina 29860 (US). **MASON, JR., Jack, T.** [US/US]; 3144 A Bath-Patterson Road, Hephzibah, South Carolina 30815 (US).
- (74) Agent: **DORITY & MANNING, P.A.**; P.O. Box 1449, Greenville, South Carolina 29602 (US).
- (81) Designated States (unless otherwise indicated, for every kind of national protection available): AE, AG, AL, AM, AT, AU, AZ, BA, BB, BG, BR, BW, BY, BZ, CA, CH, CN, CO, CR, CU, CZ, DE, DK, DM, DZ, EC, EE, EG, ES, FI, GB, GD, GE, GH, GM, HR, HU, ID, IL, IN, IS, JP, KE, KG, KP, KR, KZ, LC, LK, LR, LS, LT, LU, LV, MA, MD, MG, MK, MN, MW, MX, MZ, NA, NI, NO, NZ, OM, PG, PH, PL, PT, RO, RU, SC, SD, SE, SG, SK, SL, SY, TJ, TM, TN, TR, TT, TZ, UA, UG, US, UZ, VC, VN, YU, ZA, ZM, ZW.
- (84) Designated States (unless otherwise indicated, for every kind of regional protection available): ARIPO (BW, GH, GM, KE, LS, MW, MZ, NA, SD, SL, SZ, TZ, UG, ZM, ZW), Eurasian (AM, AZ, BY, KG, KZ, MD, RU, TJ, TM), European (AT, BE, BG, CH, CY, CZ, DE, DK, EE, ES, FI, FR, GB, GR, HU, IE, IT, LU, MC, NL, PL, PT, RO, SE, SI, SK, TR), OAPI (BF, BJ, CF, CG, CI, CM, GA, GN, GQ, GW, ML, MR, NE, SN, TD, TG).
- Declaration under Rule 4.17:**
— of inventorship (Rule 4.17(iv)) for US only
- Published:**
— without international search report and to be republished upon receipt of that report
- For two-letter codes and other abbreviations, refer to the "Guidance Notes on Codes and Abbreviations" appearing at the beginning of each regular issue of the PCT Gazette.*



WO 2005/016765 A2

(54) Title: APPARATUS FOR CARRYING CARGO

(57) Abstract: The present invention discloses and claims an apparatus for attaching to a vehicle for carrying cargo. The apparatus includes a base and at least one wing having retracted and extended positions. The apparatus occupies a smaller volume when the wing is retracted than when the wing is extended.

APPARATUS FOR CARRYING CARGO

Background of the Invention

[0001] It is known in the art to attach a platform to a vehicle for increasing the carrying capacity of the vehicle. The platform generally consists of a rectangular surface that attaches to a trailer or receiver hitch on the vehicle. In this manner, the platform undesirably extends the length of the vehicle. However, the benefit of carrying additional cargo external to the vehicle generally outweighs the detriment of lengthening the vehicle.

[0002] When additional carrying capacity is not needed, it is desirable to store the platform in a convenient, readily accessible location. One solution, as shown in U.S. Patents 4,744,590; 6,382,486; and 6,513,690, is to fold the platform toward the vehicle and leave the platform attached to the vehicle in this folded position. Although this solution ensures that the platform is readily accessible, the platform still adds some length to the vehicle. In addition, the folded platform may be aesthetically undesirable or it may interfere with the vehicle's trunk or tailgate operation.

[0003] Another solution is to remove the platform from the vehicle and store the platform until needed. Although this solution restores the vehicle to its original length, the platform is generally too bulky to store inside the vehicle, and storing the platform separate from the vehicle limits the accessibility of the platform.

[0004] Therefore, the need exists for a cargo carrier that can increase the carrying capacity for a vehicle and that can also be conveniently stored with the vehicle when not in use.

Summary of the Invention

[0005] Objects and advantages of the invention are set forth below in the following description, or may be obvious from the description, or may be learned through practice of the invention.

[0006] In one embodiment of the invention, an apparatus for attaching to a vehicle for carrying cargo includes a base, a mounting sleeve for attaching the apparatus to the

vehicle, and a wing moveably connected to the base. The wing has extended and retracted positions so that the wing is substantially coplanar with the base in the extended position and transverse to the base in the retracted position. Furthermore, the apparatus occupies a smaller volume when the wing is in the retracted position than when the wing is in the extended position.

[0007] In other embodiments of the invention, the apparatus may include more than one wing moveably connected to the base. One or more of the wings may include an inner section moveably attached to an outer section so that the inner section resides within the outer section in the retracted position. Alternately, the outer section may reside in the inner section in the retracted position. The apparatus may further include a locking mechanism for locking one of the wings in the retracted position.

[0008] Those of ordinary skill in the art will better appreciate the features and aspects of such embodiments, and others, upon review of the specification.

Brief Description of the Drawings

[0009] A full and enabling disclosure of the present invention, including the best mode thereof to one skilled in the art, is set forth more particularly in the remainder of the specification, including reference to the accompanying figures, in which: ...

[0010] Figure 1 is a perspective view of an embodiment of the present invention;

[0011] Figure 2 is a close-up perspective view of the embodiment depicted in Figure 1;

[0012] Figure 3 is a perspective view of the embodiment depicted in Figure 1 as partially folded;

[0013] Figure 4 is a perspective view of the embodiment depicted in Figure 1 as fully folded; and

[0014] Figure 5 is a perspective view of an alternate embodiment of the present invention as partially folded.

Detailed Description of Preferred Embodiments

[0015] Reference will now be made in detail to present embodiments of the invention, one or more examples of which are illustrated in the accompanying drawings.

Each example is provided by way of explanation of the invention, not limitation of the invention. In fact, it will be apparent to those skilled in the art that modifications and variations can be made in the present invention without departing from the scope or spirit thereof. For instance, features illustrated or described as part of one embodiment may be used on another embodiment to yield a still further embodiment. Thus, it is intended that the present invention covers such modifications and variations as come within the scope of the appended claims and their equivalents.

[0016] The present invention relates to a collapsible cargo carrier that attaches to a vehicle to increase the carrying capacity of the vehicle. When not in use, the carrier folds up for convenient detachment and storage within the vehicle.

[0017] As shown in Figure 1, the carrier 10 generally includes a base 20, a mounting sleeve 30, and one or more wing assemblies 40. The base 20 provides a sturdy foundation to which the other components may attach. The base 20 is typically a flat, solid structure, as shown in Figure 1, or it may include perforations to reduce its weight. The base 20 may be made of metal, plastic, fiberglass, or a combination thereof, depending on the particular uses and needs. The base may include one or more raised sides 22 to further define the carrier 10 and provide additional attachment points.

[0018] The mounting sleeve 30 fixedly attaches to the base 20 and provides a means for attaching the carrier 10 to a vehicle. As shown in Figure 1, the mounting sleeve 30 may be a square collar 32 with an aperture 34 suited to mate with a drawbar 36 from a conventional receiver hitch. The mounting sleeve 30 receives the drawbar 36, and a clevis pin, cotter pin, bolt, or other suitable structure (not shown) fits through a hole 38 in the mounting sleeve 30 and drawbar 36 to secure the mounting sleeve 30 to the drawbar 36. In other embodiments, the mounting sleeve 30 may be a clamp, vice grip, or other structure more suitable for securely engaging the carrier 10 to a ball-type trailer hitch.

[0019] The wing assemblies 40 moveably connect to the base 20 and provide the remainder of the surface area for carrying cargo. Figure 1 illustrates one embodiment of a carrier 10 with symmetric, multi-sectional wing assemblies 40 on opposing sides of the carrier's longitudinal axis, although other orientations are within the scope of the present invention. Moreover, although Figure 1 depicts an embodiment with each wing assembly 40 having an inner section 41 and an outer section 42, it should be understood by one of ordinary

skill in the art that wing assemblies 40 having fewer or more sections are within the scope of the present invention.

[0020] Each wing assembly 40 includes an expanded metal surface 44, vertical siding 46, and horizontal support bars 48. The expanded metal surface 44 extends between the vertical siding 46 and provides the horizontal surface area for carrying cargo. The use of expanded metal reduces the weight of the wing assembly 40; however, it should be understood by one of ordinary skill in the art that a solid sheet of material is an equivalent substitute within the scope of the present invention.

[0021] The vertical siding 46 defines the perimeter and provides additional structural support for the wing assemblies 40. The vertical siding 46 may include a slideable attachment 50 and/or a locking mechanism, as shown in more detail in Figure 2. The slideable attachment 50 allows relative movement between two parts, such as between the wing assembly 40 and the base 20 or between inner 41 and outer 42 sections of the wing assembly 40. The slideable attachment 50 may use rivets, bolts, hinges, slides, or other suitable substitutes. In alternate embodiments, the slideable attachment 50 may be located on other parts of the wing assembly 40, such as the underside of the expanded metal surface 44 and/or horizontal support bars 48.

[0022] The locking mechanism secures the wing assembly 40 in a desired position. Although various suitable mechanisms are known to one of ordinary skill in the art and within the scope of the present invention, one such mechanism is a spring button 60 depicted in Figures 1, 2, and 3. As shown, the spring button 60 attaches to the vertical siding 46 at one end 62 and has a button (not shown) at the other end 64. The button fits into a detent 66 in the vertical siding 46 to lock the wing assembly 40 into retracted or extended positions.

[0023] The horizontal support bars 48 extend between the vertical siding 46 and provide structural support for the expanded metal surface 44. In one embodiment, the horizontal support bars 48 attach to the vertical siding 46 using rivets, bolts, tack welds, or similar suitable methods. The expanded metal surface 44 then attaches to the horizontal support bars 48 in similar fashion. In another embodiment, the vertical siding 46 includes a support flange 49, and the horizontal support bars 48 attach to the support flange 49. The expanded metal surface 44 in turn attaches to the horizontal support bars 48 and/or the vertical siding 46. It should be understood by one of ordinary skill in the art that alternate

embodiments within the scope of the present invention may employ other methods for securing the expanded metal surface **44**, vertical siding **46**, and horizontal support bars **48**.

[0024] Figures 1, 3, and 4 illustrate one embodiment of the present invention in various positions. In Figure 1, the carrier **10** is fully extended, as it would be when installed on a vehicle. To fully retract one wing assembly **40**, as depicted in Figure 3, the outer section **42** of the wing assembly **40** folds into the inner section **41**. The spring button **60** is then depressed to unlock the wing assembly **40**, and the entire wing assembly **40** rotates roughly perpendicular to the base **20** until the spring button **60** locks the wing assembly **40** in a fully retracted position. Figure 4 depicts the carrier **10** in a fully retracted position, as it would be when installing or removing the carrier **10** on a vehicle or when the carrier **10** is in storage.

[0025] Figure 4 depicts an additional feature present in some embodiments of the present invention. As shown, the wing assemblies **40** may further include a U-shaped structure **70** attached to the horizontal support bars **48**, or other suitable structure on the wing assembly **40**. When the wing assembly **40** is in the folded position, the U-shaped structure **70** serves as a convenient handle for moving the carrier **10**. In the extended position, the U-shaped structure **70** is beneath the expanded metal surface **42** and provides additional support for the wing assembly **40**.

[0026] Figure 5 depicts an alternate embodiment of the present invention with a modified wing assembly **80**. The modified wing assembly **80** includes an extension slide **82** mounted on the vertical siding **46** for slideably connecting the inner **41** and outer **42** sections. The extension slide **82** includes a ball bearing or nylon roller **84** that rides in a track **86** between the inner **41** and outer **42** sections, although other types of extension slides are known to one of ordinary skill in the art and within the scope of the present invention. In the modified wing assembly **80**, the outer section **42** slides on the extension slide **80** toward or away from the base **20** to reach a retracted or extended position, respectively. In this manner, the carrier has retracted and extended positions, as before. In addition, the carrier also has intermediate positions in which the modified wing assemblies **80** are rotated to be coplanar with the base **20** while one or both of the outer sections **42** remains retracted within its associated inner section **41**.

[0027] It should be appreciated by those skilled in the art that modifications and variations can be made to the embodiments of the invention set forth herein without departing

from the scope and spirit of the invention as set forth in the appended claims and their equivalents.

WHAT IS CLAIMED IS:

1. An apparatus for attaching to a vehicle for carrying cargo comprising:
 - a. a base;
 - b. a mounting sleeve proximate to said base for attaching said base to the vehicle;
 - c. a first wing moveably connected to said base;
 - 5 d. a second wing moveably connected to said base and opposite said first wing;
 - e. said first and second wings each having an extended and a retracted position;
 - f. wherein said first and second wings are substantially coplanar with said base in said extended position; and
 - 10 g. wherein said first and second wings are transverse to said base in said retracted position.
2. The apparatus of claim 1, wherein said apparatus occupies a smaller volume when at least one of said first and second wings is in said retracted position than when both of said first and second wings are in said extended position.
3. The apparatus of claim 1, wherein said first and second wings each comprise
 - a. an inner section proximate to said base and
 - b. an outer section moveably attached to said inner section and separated from said base by said inner section in said extended position.
4. The apparatus of claim 3, wherein for at least one of said first and second wings, said outer section resides within said inner section in said retracted position.
5. The apparatus of claim 3, wherein for at least one of said first and second wings, said inner section resides within said outer section in said retracted position.
6. The apparatus of claim 3, wherein at least one of said first and second wings further includes a hinge for moveably attaching said inner section to said outer section.
7. The apparatus of claim 1, wherein said base includes a locking mechanism for locking

at least one of said first and second wings in said retracted position.

8. An apparatus for attaching to a vehicle for carrying cargo comprising:
 - a. a base;
 - b. a mounting sleeve proximate to said base for attaching said base to the vehicle;
 - c. a first wing moveably connected to said base;
 - 5 d. a second wing moveably connected to said base and opposite said first wing; and
 - e. wherein each of said first and second wings has an extended and a retracted position.
9. The apparatus of claim 8, wherein said first and second wings are substantially coplanar with said base in said extended position.
10. The apparatus of claim 8, wherein said first and second wings are transverse to said base in said retracted position.
11. The apparatus of claim 8, wherein said apparatus occupies a smaller volume when at least one of said first and second wings is in said retracted position than when both of said first and second wings are in said extended position.
12. The apparatus of claim 8, wherein said first and second wings each comprise
 - a. an inner section proximate to said base and
 - b. an outer section moveably attached to said inner section and separated from said base by said inner section in said extended position.
13. The apparatus of claim 12, wherein for at least one of said first and second wings, said outer section resides within said inner section in said retracted position.
14. The apparatus of claim 12, wherein for at least one of said first and second wings, said inner section resides within said outer section in said retracted position.

15. The apparatus of claim 12, wherein at least one of said first and second wings further includes a hinge for moveably attaching said inner section to said outer section.
16. The apparatus of claim 8, wherein said base includes a locking mechanism for locking at least one of said first and second wings in said retracted position.
17. An apparatus for attaching to a vehicle for carrying cargo comprising:
 - a. a base;
 - b. a mounting sleeve proximate to said base for attaching said base to the vehicle;
 - c. a first wing moveably connected to said base and having an extended and a retracted position; and
 - d. wherein said apparatus occupies a smaller volume when said first wing is in said retracted position than when said first wing is in said extended position.
18. The apparatus of claim 17, wherein said first wing is transverse to said base in said retracted position.
19. The apparatus of claim 17, wherein said apparatus occupies a smaller volume when said first wing is in said retracted position than when said first wing is in said extended position.
20. The apparatus of claim 17, further including a second wing moveably connected to said base and opposite said first wing.

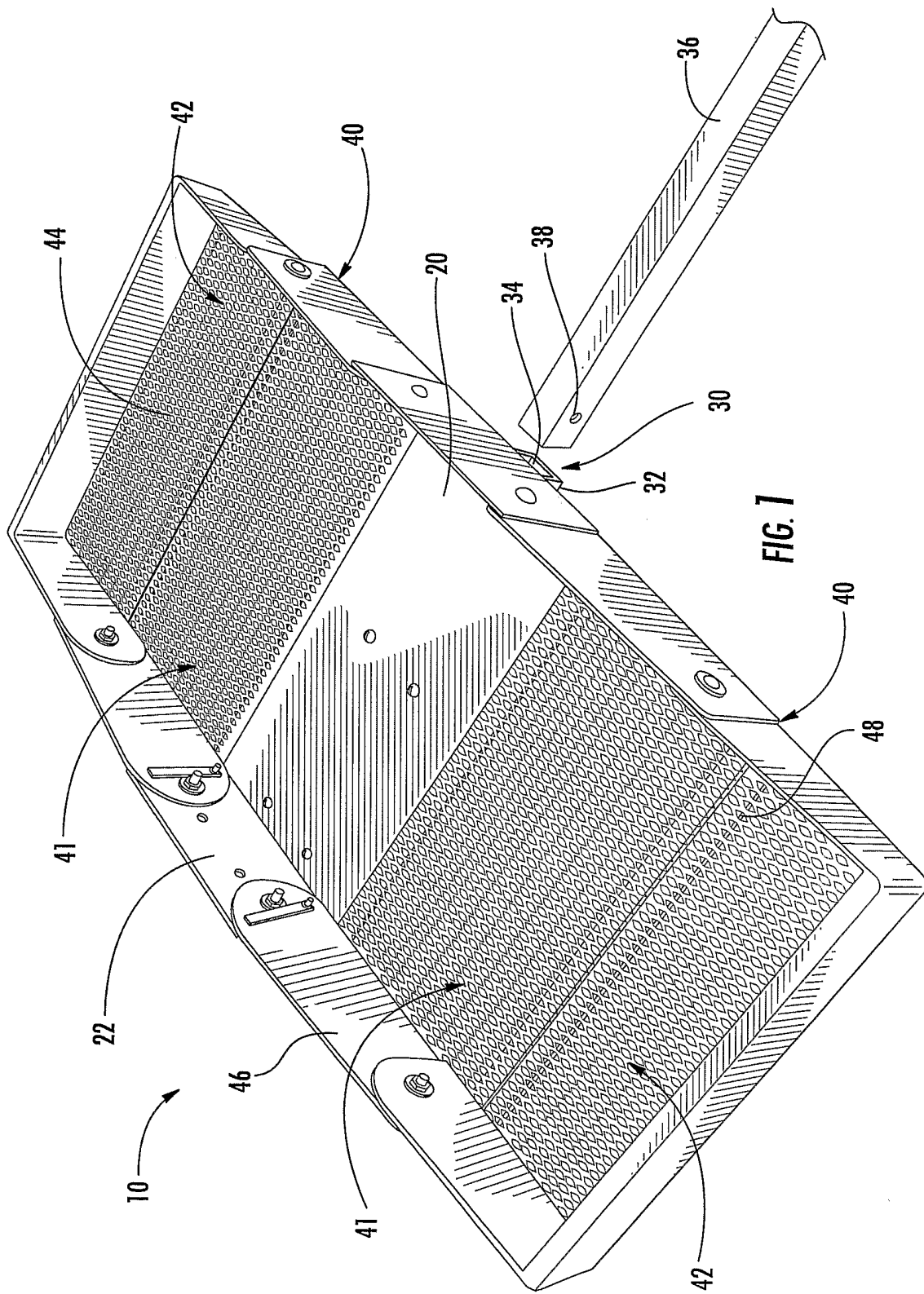

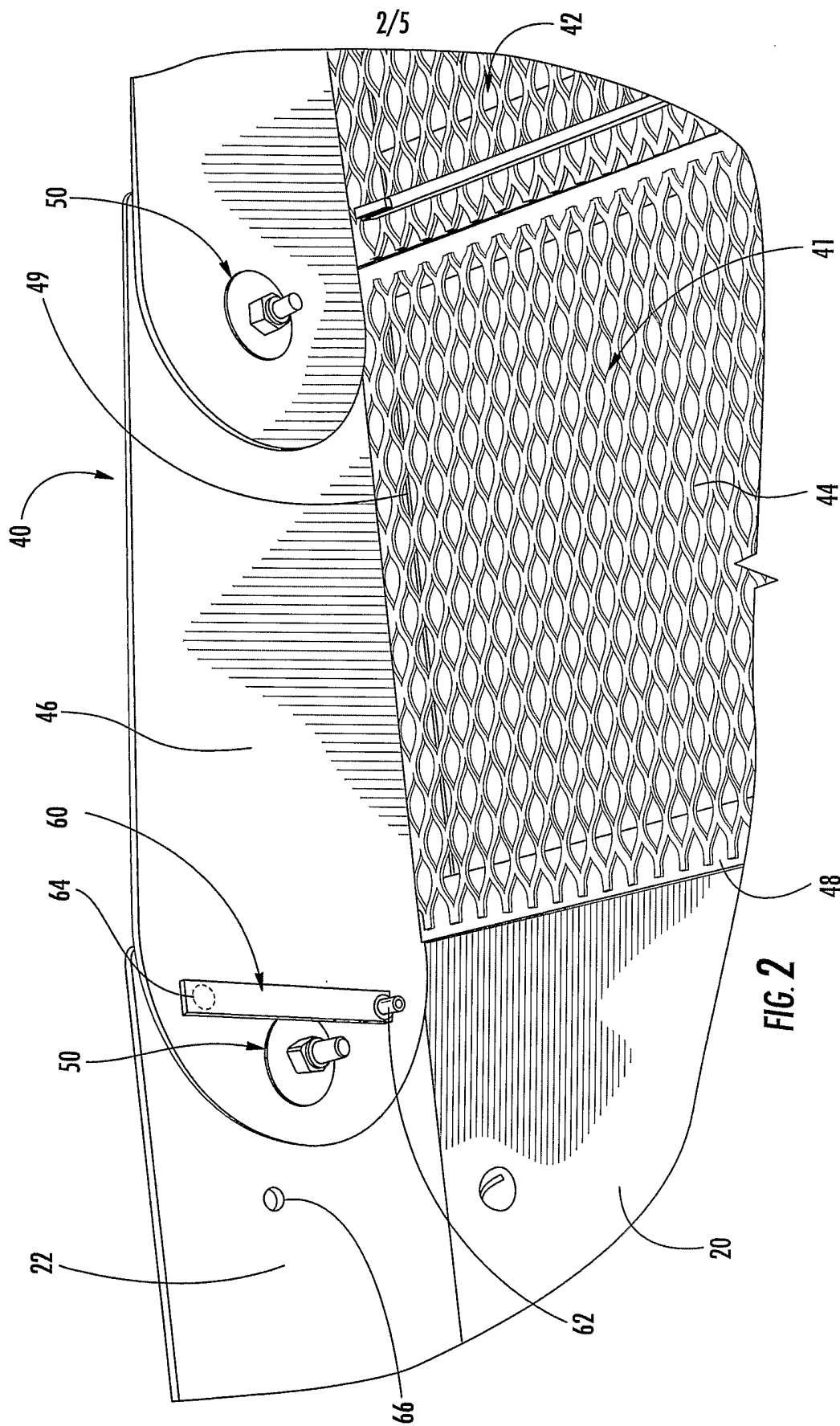

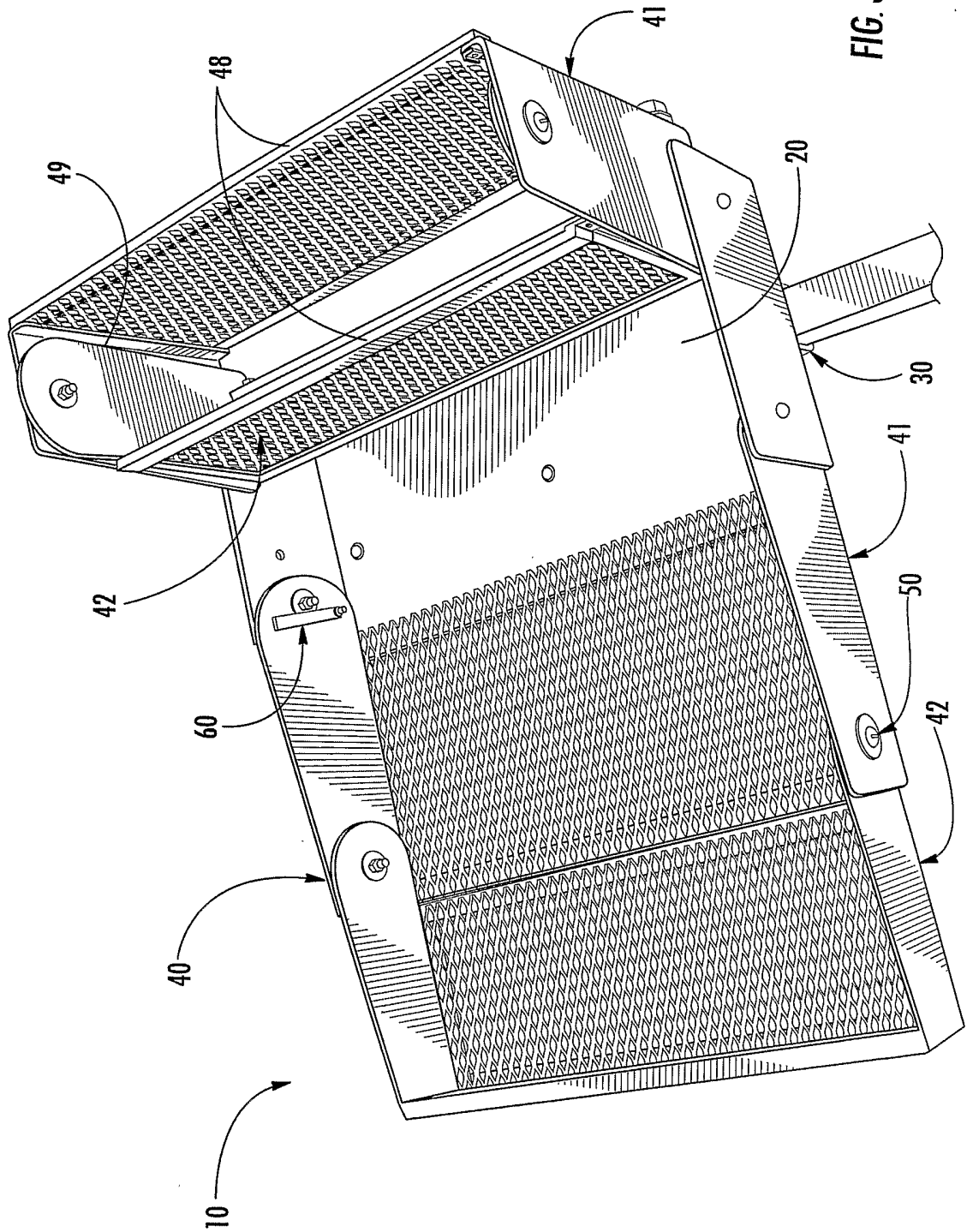

FIG. 3

4/5

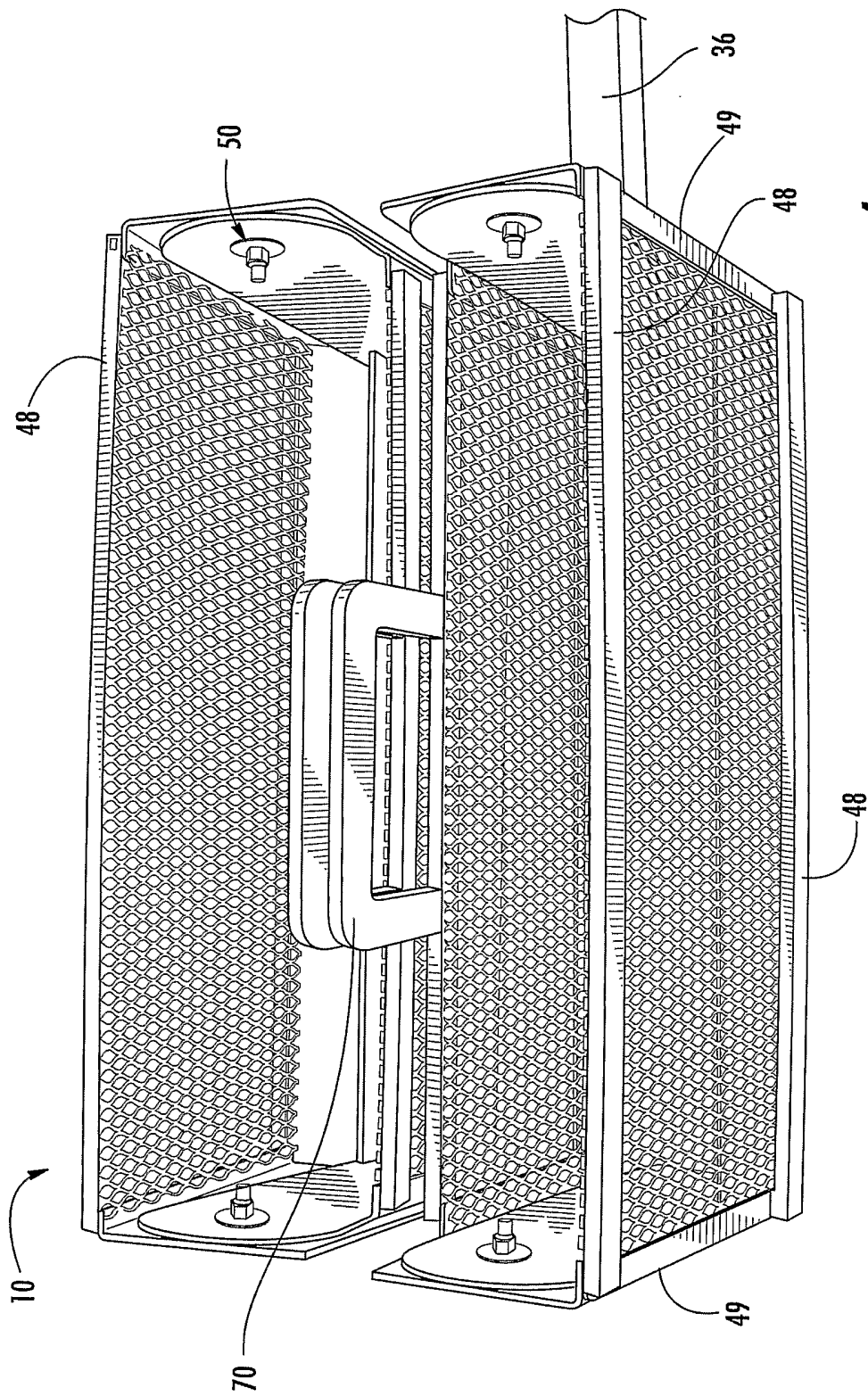

FIG. 4

