

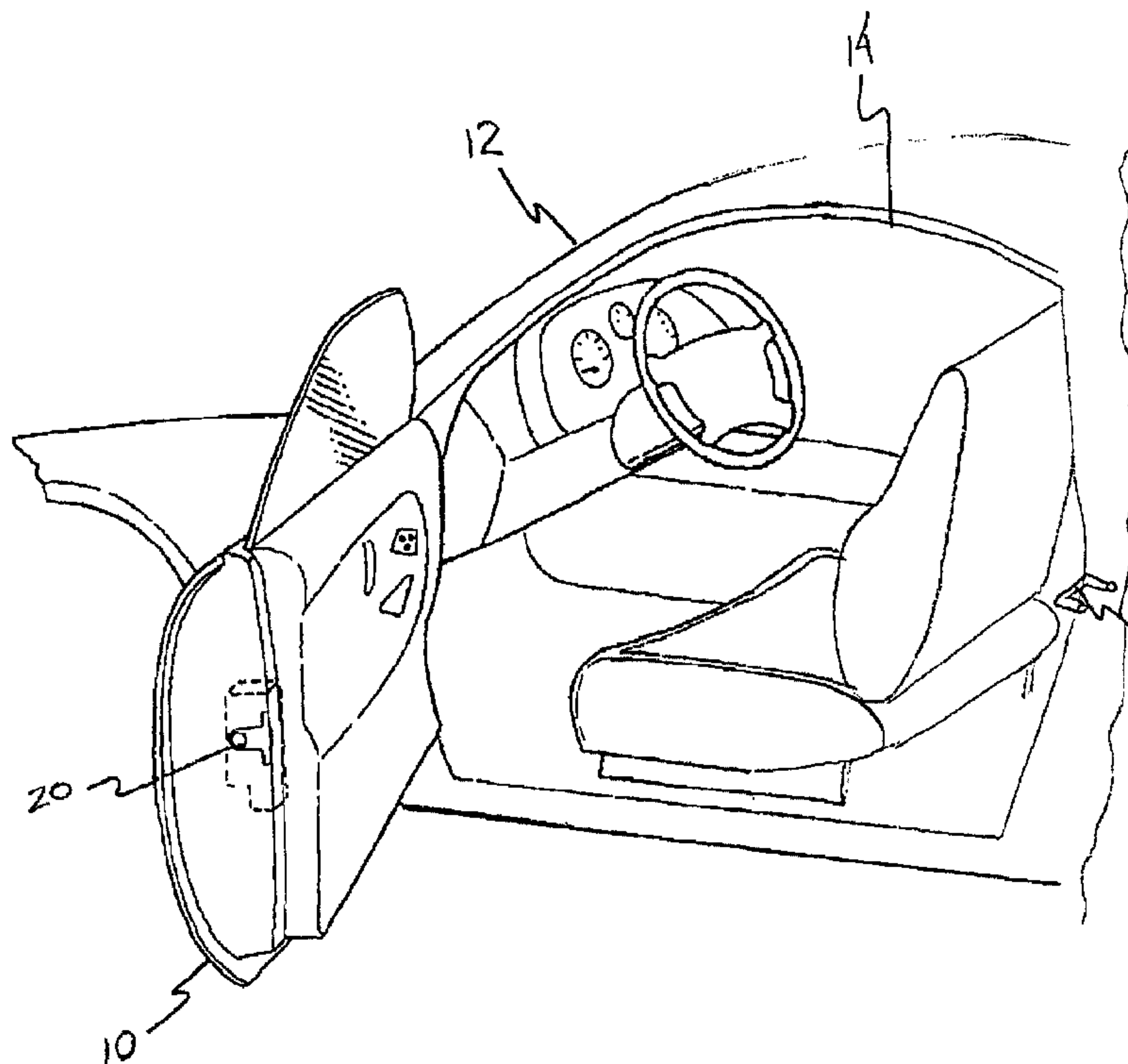

(22) Date de dépôt/Filing Date: 2002/09/05
(41) Mise à la disp. pub./Open to Public Insp.: 2004/01/26
(30) Priorité/Priority: 2002/07/26 (60/398,978) US

(51) Cl.Int.⁷/Int.Cl.⁷ E05B 65/20
(71) Demandeur/Applicant:
INTIER AUTOMOTIVE CLOSURES INC., CA
(72) Inventeurs/Inventors:
TAIT, ROBERT, US;
PEREVERZE, JAMES, US;
LOSCHIAVO, JAMES, US
(74) Agent: IMAI, JEFFREY T.

(54) Titre : LOQUET A INERTIE POUR DISPOSITIF DE VERROUILLAGE DE VEHICULE
(54) Title: INERTIA CATCH FOR A VEHICLE LATCH



(57) **Abrégé/Abstract:**

A latch mechanism for selectively latching a door to an automotive vehicle. The latch mechanism includes a latch hook movable between locked and unlocked positions relative to a striker bar fixedly secured to the vehicle. A release lever is operatively coupled between the latch hook and the latch mechanism for selectively actuating the latch hook between the locked and unlocked positions. An inertia lever is engagable with the release lever to prevent movement of the latch hook between the unlocked and locked positions. The inertia lever is movably coupled to the latch mechanism for movement in and out of engagement with the release lever in response to a threshold acceleration of the vehicle. A slot is formed in the release lever presenting sides engagable with the inertia lever to automatically move the inertia lever in response to movement of the release lever to prevent seizing of the inertia lever within the latch mechanism due to lack of use.

ABSTRACT

A latch mechanism for selectively latching a door to an automotive vehicle. The latch mechanism includes a latch hook movable between locked and unlocked positions relative to a striker bar fixedly secured to the vehicle. A release lever is operatively coupled between the latch hook and the latch mechanism for selectively actuating the latch hook between the locked and unlocked positions. An inertia lever is engagable with the release lever to prevent movement of the latch hook between the unlocked and locked positions. The inertia lever is movably coupled to the latch mechanism for movement in and out of engagement with the release lever in response to a threshold acceleration of the vehicle. A slot is formed in the release lever presenting sides engagable with the inertia lever to automatically move the inertia lever in response to movement of the release lever to prevent seizing of the inertia lever within the latch mechanism due to lack of use.

VEHICLE DOOR LATCH WITH INERTIA CATCH MECHANISM

BACKGROUND OF THE INVENTION

5 1. Field of the Invention

The invention relates to a latch for selectively locking a door of an automotive vehicle, and more particularly, a lateral inertia lever for preventing the release of the latch in the event of a lateral vehicle impact.

10 2. Description of the Prior Art

Automotive vehicles include hinged doors for allowing and closing access to passenger or cargo compartments within the vehicle. Typically, a latch mechanism is coupled between the door and the vehicle for releasably locking the door in a closed position with the vehicle. A release mechanism is typically coupled to the latch mechanism for
15 selectively locking and unlocking the latch mechanism. It remains desirable to provide a mechanism for preventing the latch mechanism from unlocking during a side impact upon the vehicle.

SUMMARY OF THE INVENTION

20 According to one aspect of the invention, a latch mechanism is provided for selectively latching a door to an automotive vehicle. The latch mechanism includes a latch hook movable between locked and unlocked positions. A release lever is operatively coupled to the latch hook for selectively moving the latch hook between the locked and unlocked
25 positions. The latch mechanism includes an inertia lever engagable with the release lever to prevent movement of the latch hook between the locked and unlocked positions. The inertia lever is movably supported within the latch mechanism for moving in and out of engagement with the release lever in response to a side impact upon the vehicle.

BRIEF DESCRIPTION OF THE DRAWINGS

30

Advantages of the present invention will be readily appreciated as the same becomes better understood by reference to the following detailed description when considered in connection with the accompanying drawings wherein:

Figure 1 is a partial perspective view of an automotive vehicle incorporating a latch mechanism according to one embodiment of the invention;

Figure 2 is a partially exploded perspective view of the latch mechanism;

Figure 2a is a perspective view of a release lever in the latch mechanism; and

5 Figure 3 is a perspective view of the latch mechanism.

DETAILED DESCRIPTION OF THE PREFERRED EMBODIMENT

Referring to the figures, Figure 1 illustrates a door 10 for an automotive vehicle 12 incorporating a latch 20 mechanism according to one embodiment of the invention. The door 10 is hinged to the vehicle 12 for pivotal movement between a closed position nested within an opening 14 in the vehicle and opened position to allow access into the vehicle 12 through the opening 14. The latch mechanism 20 is fixedly mounted to the door 10 for releasably locking the door 10 in the closed position.

15 Referring to Figures 1-3, the latch mechanism 20 includes a latch hook 22 lockably engagable with a striker bar 24 fixedly secured to the vehicle 12. The latch hook 22 is movable between a locked position lockingly engaged with the striker bar 24 and an unlocked position disengaged with the striker bar 24 to allow movement of the door 12 between the closed and opened positions. The latch hook 22 is biased toward the locked position by a biasing member (not shown) of any suitable variety, such as a clock spring extending between the latch mechanism 20 and the latch hook 22. A release lever 30 is pivotally mounted to a mounting bracket 31 in the latch mechanism 20 and operatively coupled to the latch hook 22 for moving the latch hook 22 between the locked and unlocked positions in response to clockwise and counterclockwise movement of the release lever 30, as viewed in
20 Figures 2 and 3. A detailed description of the structure and function of such a latch mechanism 20 is disclosed in applicant's United States Patent 6,328,333 B1 issued on December 11, 2001, which is incorporated herein by reference in its entirety.

The release lever 30 includes a proximal end 32 pivotally coupled to the mounting bracket 31 by a pivot pin 33 and an opposite distal end 34 extending outwardly from the latch
30 mechanism 20. The release lever 30 includes opposite upper and lower edges 36, 38 extending longitudinally between the proximal and distal ends 32, 34. A raised abutment surface 40 is formed along a portion of the lower edge 38 adjacent the distal end 34. A relief slot 42 is cut or formed in the lower edge 38 between the proximal end 32 and the abutment surface 40. The slot 42 extends between opposing first and second sides 44, 46. The first

side 44 of the slot 42 and the lower edge 38 intersect to present a generally raised abutment tip 48.

The latch mechanism 20 includes an inertia lever 50 extending between opposite proximal and distal ends 52, 54. The distal end 54 is defined by a bent tab 58 engagable with either the abutment surface 40 or the slot 42 in the release lever 30. The proximal end 52 of the inertia lever 50 is pivotally coupled to the mounting bracket 31 by a pivot pin 56 for moving the tab 58 between engagement with the abutment surface 40 or the slot 42. A biasing member 60 extends between the inertia lever 50 and the latch mechanism 20 for biasing the inertia lever 50 in a counterclockwise direction, as viewed in the figures, towards engagement with a stop 62 formed in the mounting bracket 31. With the inertia lever 50 abutting the stop 62, the tab 58 is presented for moving in and out of the slot 42 to allow counterclockwise and clockwise movement of the release lever 30 about the pivot pin 33 for actuating the latch hook 22 between the unlocked and locked positions, respectively. The first side 44 of the slot 42 and the tip 48 engage the tab 58 to lightly toggle the inertia lever 50 in and out of contact with the stop 62 during clockwise and counterclockwise rotation of the release lever 30.

A weight 70 is fixedly secured to the inertia lever 50 between the proximal and distal ends 52, 54 by any suitable means, such as welding or bolting. The weight 70 has a predetermined mass and is secured to the inertia lever 50 at a predetermined distance from the pivot pin 56 to cause clockwise rotation of the inertia lever 50 against the bias of the biasing member 60 beyond a threshold lateral acceleration of the vehicle generally associated with a side impact upon the vehicle.

In operation, under normal vehicle operating conditions, the release lever 30 is rotated counterclockwise and clockwise for actuating the latch hook 22 between the unlocked and locked positions, respectively. The biasing member 60 continuously biases the inertia lever 50 against the stop 62. The first side 44 and the tip 48 engage the tab 58 to move the inertia lever 50 in and slightly out of contact with the stop 62 during clockwise and counterclockwise rotation of the release lever 30 to prevent the lever 50 from binding on the pivot pin 56.

In the event of a side impact of the vehicle 12 or similar sudden acceleration, the weight 70 applies a torque moment upon the inertia lever 50 to cause the inertia lever 50 to rotate clockwise so that the tab 58 is presented for engaging the abutment surface 40. Should the release lever 30 rotate counterclockwise, the abutment surface 40 will engage the tab 58. While engaged with the abutment surface 40, the tab 58 prevents actuation of the latch hook

22 to the unlocked position by preventing counterclockwise movement of the release lever
30.

The invention has been described in an illustrative manner, and it is to be understood
that the terminology, which has been used, is intended to be in the nature of words of
5 description rather than of limitation.

Many modification and variations of the present invention are possible in light of the
above teachings. It is, therefore, to be understood that within the scope of the appended
claims, the invention may be practiced other than as specifically described.

What is claimed is:

1. A latch mechanism for selectively latching a door to an automotive vehicle, said latch mechanism comprising:
 - 5 a latch hook movable between a locked position and an unlocked position;
 - a release lever operatively coupled to said latch hook for selectively moving said latch hook between said locked and unlocked positions; and
 - an inertia lever engagable with said release lever to prevent movement of said latch hook between said locked and unlocked positions, said inertia lever movably supported
 - 10 within said latch mechanism for moving in and out of engagement with said release lever in response to a side impact upon the vehicle.

2. A latch mechanism as set forth in claim 1 wherein said release mechanism includes a slot presenting sides for engaging a portion of said inertia lever for automatically toggling
- 15 said inertia lever in response to movement of said release lever to prevent seizing of said inertia lever within the latch mechanism.

Application number / numéro de demande: 2401397

Figures: 3

Pages: _____

Unscannable items
received with this application
(Request original documents in File Prep. Section on the 10th floor)

Documents reçu avec cette demande ne pouvant être balayés
(Commander les documents originaux dans la section de préparation des dossiers au
10ème étage)

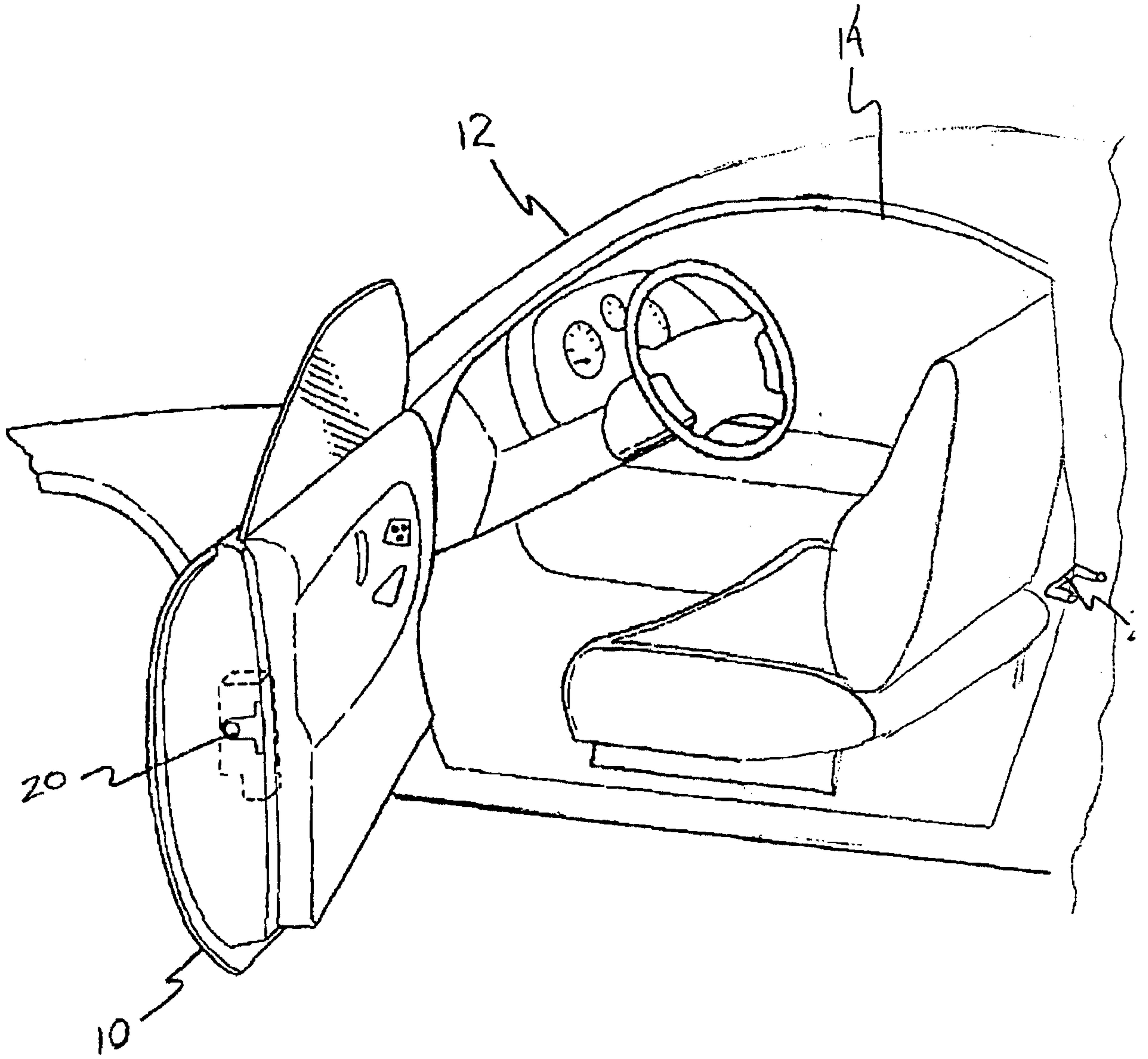

FIGURE 1

11

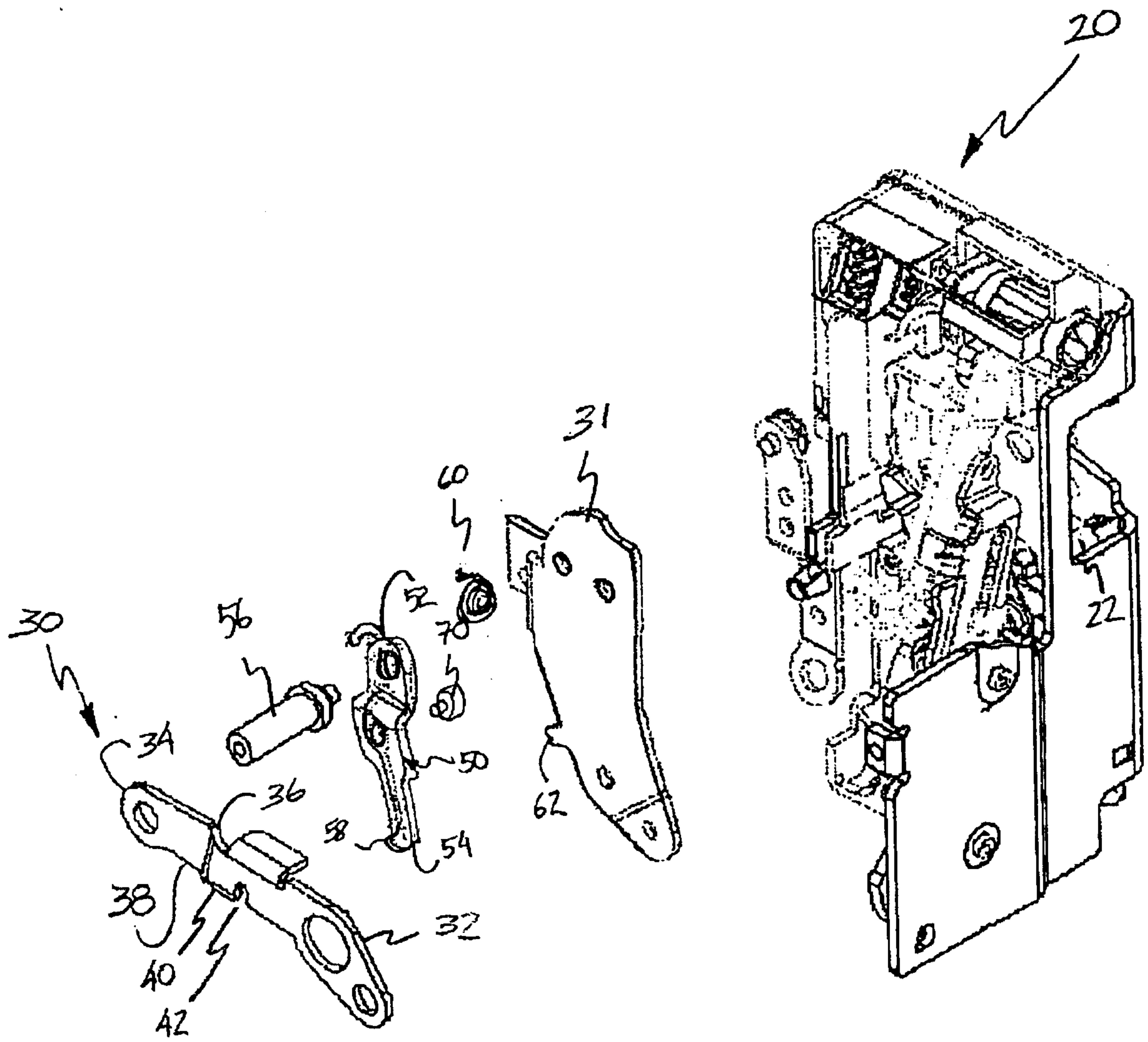

FIGURE 2

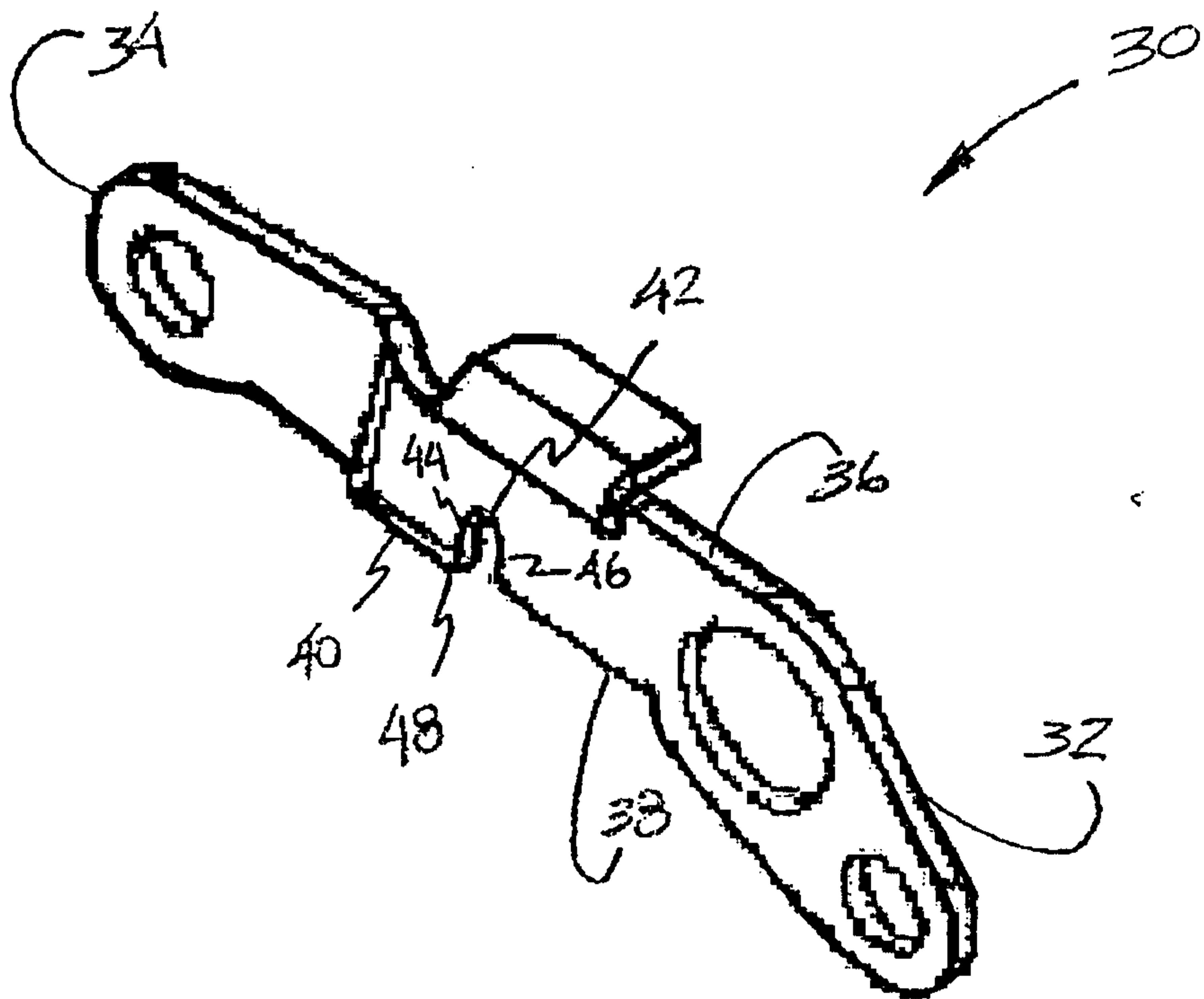

FIGURE 2a

==

