



(22) Date de dépôt/Filing Date: 2021/04/21

(41) Mise à la disp. pub./Open to Public Insp.: 2021/06/23

(45) Date de délivrance/Issue Date: 2022/07/26

(51) Cl.Int./Int.Cl. *F16L 5/10* (2006.01),
E04B 1/66 (2006.01)

(72) Inventeur/Inventor:
BRIGHAM, GRAHAM, CA

(73) Propriétaire/Owner:
INTEGRITY PRODUCTS & SUPPLIES INC., CA

(74) Agent: PROWSE CHOWNE LLP

(54) Titre : JOINT D'ETANCHEITE POUR UNE SAILLIE ET METHODE D'UTILISATION

(54) Title: A SEAL FOR A PROTRUSION AND METHOD OF USE

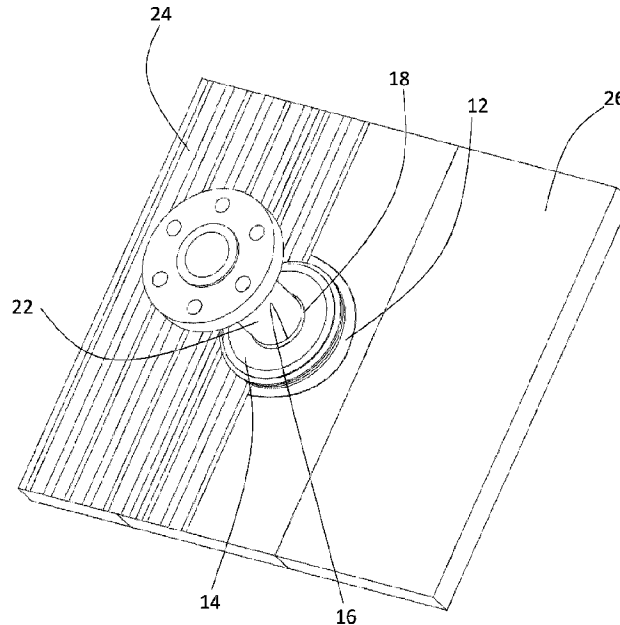

(57) **Abrégé/Abstract:**

A seal for a protrusion has a flexible lower flange and a flexible upper flange. An aperture extends through the flexible lower flange and the flexible upper flange. The aperture has a wall. The wall attaches the flexible lower flange to the flexible upper flange such that the flexible lower flange and the flexible upper flange are spaced from each other. A slit extends from an outer edge of the lower flange through the upper flange and the wall of the aperture such that the slit allows the lower flange and the upper flange to be slid over a protrusion such that the wall of the aperture encircles the protrusion and the lower flange and the upper flange return to their original shape.



ABSTRACT

A seal for a protrusion has a flexible lower flange and a flexible upper flange. An aperture extends through the flexible lower flange and the flexible upper flange. The aperture has a wall. The wall attaches the flexible lower flange to the flexible upper flange such that the flexible lower flange and the flexible upper flange are spaced from each other. A slit extends from an outer edge of the lower flange through the upper flange and the wall of the aperture such that the slit allows the lower flange and the upper flange to be slid over a protrusion such that the wall of the aperture encircles the protrusion and the lower flange and the upper flange return to their original shape.

TITLE

[0001] A Seal for a Protrusion and Method of Use

5

FIELD OF THE DISCLOSURE

[0002] The present application relates generally to a seal for a protrusion, more specifically it relates to a seal for a protrusion in an insulated system.

10

BACKGROUND

[0003] This section provides background information to facilitate a better understanding of the various aspects of the invention. It should be understood that the statements in this section of this document are to be read in this light, and not as admissions of prior art.

15

[0004] Protrusions from insulated equipment and systems are a major source of moisture ingress. In general practice, voids between the outer periphery of protruding nozzles or pipes and jacketing are filled with silicon sealants. The silicon sealants can become damaged by weathering or poor workmanship, exposing the voids. This, in turn, allows the moisture to penetrate via the voids and damage insulation and metal underneath insulation from corrosion and stress corrosion cracking.

20

BRIEF SUMMARY

[0005] There is provided a seal for a protrusion with a flexible lower flange and a flexible upper flange.

25

An aperture extends through the flexible lower flange and the flexible upper flange. The aperture has a wall. The wall attaches the flexible lower flange to the flexible upper flange such that the flexible lower flange and the flexible upper flange are spaced from each other. A slit extends from an outer edge of the flexible lower flange through the flexible upper flange and the wall of the aperture such that the slit allows the flexible lower flange and the flexible upper flange to be slid over a protrusion such that the wall of the aperture encircles the protrusion and the flexible lower flange and the flexible upper flange return to their original shape.

30

[0006] In one embodiment, the flexible upper flange is smaller in size than the flexible lower flange.

[0007] In one embodiment, the wall of the aperture extends upwards away from the flexible upper flange.

5

[0008] In one embodiment, the flexible lower flange and the flexible upper flange are circular in shape.

[0009] In one embodiment, the flexible lower flange and the flexible upper flange are made of silicon.

10 [0010] In one embodiment, the flexible lower flange, the flexible upper flange and the wall of the aperture are integrally formed.

[0011] In one embodiment, the aperture is positioned centrally through the flexible lower flange and the flexible upper flange

15

[0012] There is also provided a method of sealing a protrusion in an insulated system. A seal is provided that has a flexible lower flange, a flexible upper flange and an aperture extending through the flexible lower flange and the flexible upper flange. The aperture has a wall that attaches the flexible lower flange to the flexible upper flange such that the flexible lower flange and the flexible upper flange are spaced from each other. A slit extends from an outer edge of the lower flange through the upper flange and the wall of the aperture such that the slit allows the lower flange and the upper flange to be slid over a protrusion such that the wall of the apertures encircles the protrusion and the flexible lower flange and the flexible upper flange return to their original shape. The seal is slid over the protrusion such that the wall of the aperture encircles the protrusion and the flexible lower flange and the flexible upper flange return to their original shape. A bottom of the flexible lower flange contacts a surface from which the protrusion extends. An outer cladding is slid between the flexible upper flange and the flexible lower flange. The outer cladding having a cut out sized larger than the aperture and smaller than the flexible lower flange and the flexible upper flange.

20

25

30 [0013] In one embodiment, the outer cladding is separated into two pieces with the cut out being divided between the two pieces.

[0014] In one embodiment, a further step of using a sealant to seal the flexible upper flange to the outer cladding.

[0015] In one embodiment, a further step of using a sealant to seal the two pieces of the outer cladding together is completed.

5 [0016] In one embodiment, the flexible upper flange is smaller in size than the flexible lower flange.

[0017] In one embodiment, the wall of the aperture extends upwards away from the flexible upper flange.

10 [0018] In one embodiment, the flexible lower flange and the flexible upper flange are circular in shape.

[0019] In one embodiment, the flexible lower flange and the flexible upper flange are made of silicon.

[0020] In one embodiment, the flexible lower flange, the flexible upper flange and the wall of the
15 aperture are integrally formed.

[0021] In one embodiment, the aperture is positioned centrally through the flexible lower flange and the flexible upper flange

20 **BRIEF DESCRIPTION OF THE DRAWINGS**

[0022] These and other features will become more apparent from the following description in which references are made to the following drawings, in which numerical references denote like parts. The drawings are for the purpose of illustration only and are not intended to in any way limit the scope of
25 the invention to the particular embodiments shown.

[0023] FIG. 1 is a perspective view of a seal for a protrusion.

[0024] FIG. 2 is a side elevation view of the seal for a protrusion.

[0025] FIG. 3 is a perspective view of the seal installed on an insulated system.

30 [0026] FIG. 4 is a perspective view of the seal for a protrusion installed on a partially completed insulated system.

DETAILED DESCRIPTION OF THE PREFERRED EMBODIMENTS

[0027] A seal for a protrusion, generally identified by reference numeral 10, will now be described with reference to FIG. 1 through FIG. 4.

[0028] Referring to **FIG. 1**, a seal 10 is provided that has a flexible lower flange 12 and a flexible upper flange 14. In the embodiments shown, both flexible lower flange 12 and flexible upper flange 14 are circular in shape. It will be understood by a person skilled in the art that flexible lower flange 12 and flexible upper flange 14 may be any shape and flexible lower flange 12 may have a different shape than flexible upper flange 14. An aperture 16 extends through flexible lower flange 12 and flexible upper flange 14. In the embodiment shown, aperture 16 is positioned centrally in flexible lower flange 12 and flexible upper flange 14. It will be understood by a person skilled in the art that aperture 16 may be positioned anywhere through flexible lower flange 12 and flexible upper flange 14. Aperture 16 has a wall 18. Referring to **FIG. 2**, wall 18 attaches flexible lower flange 12 to flexible upper flange 14 such that flexible lower flange 12 and flexible upper flange 14 are spaced from each other. Appropriate spacing may vary depending upon the type of outer cladding 24 that is used. The flexible lower flange 12 and the flexible upper flange 14 need to be spaced far enough apart to allow outer cladding 24 to fit between them with at least a portion of outer cladding 24 contacting the flexible lower flange 12 and the flexible upper flange 14. A person of skill will understand that different spacings may be appropriate for different outer claddings 24. In the embodiments shown, flexible lower flange 12, flexible upper flange 14 and wall 18 are integrally formed as this provides the greatest sealing potential. It will be understood by a person skilled in the art that pieces may be made individually and attached together using sealants such as silicon or any other suitable sealant known to a person skilled in the art. Referring to **FIG. 1**, a slit 20 extends from an outer edge 22 of flexible lower flange 12 through flexible upper flange 14 and wall 18 of aperture 16. Slit 20 allows flexible lower flange 12 and flexible upper flange 14 to be slid over a protrusion 22, shown in **FIG. 3**, such that wall 18 of aperture 16 encircles protrusion 22 and flexible lower flange 12 and flexible upper flange 14 return to their original shape. Seal 10 may be made of silicon, plastic or any other suitable flexible material known to a person skilled in the art.

[0029] In the embodiment shown in **Fig. 1**, flexible upper flange 14 is smaller in size than flexible lower flange 12. One benefit of this is making it clear that the flexible lower flange 12 is more flexible than flexible upper flange 14 when being installed. Referring to **FIG. 3**, a second potential benefit is that it requires more accurate cutting of cutout in outer cladding 24 prior to installation. While outer cladding 24 is shown as being a panel, it will be understood that outer cladding 24 may be any shape suitable for

providing coverage. A more accurate, and smaller, cutout helps to reduce the chances of moisture ingress beyond seal 10, which in turn helps to reduce the likelihood of corrosion under insulation in insulated systems. Referring to **FIG. 4**, outer cladding 24 may be used to protect insulation material 26, wall structures or any other material that may benefit by being protected from moisture.

5

[0030] To aid in sealing, wall 18 of aperture 16 may extend upwards away from flexible upper flange 14. Increasing the length of wall 18 results in greater contact points for wall 18 and protrusion 22. Greater contact between wall 18 and protrusion 22 helps to reduce the chances of moisture ingress beyond seal 10. Reducing moisture ingress can greatly reduce the likelihood of corrosion under insulation in insulated systems.

10

[0031] In the embodiment shown in **FIG. 1**, fastening apertures 28 are provided in flexible upper flange 14 to allow fasteners, such as screws, to hold outer cladding 24 in position within seal 10. To help reduce the risk of moisture ingress through fastening apertures 28, washers may be used to provide additional sealing between fastener and fastener apertures 28. It will be understood by a person skilled in the art that fastening apertures 28 are optional features and may not be useful in all situations. It is preferred that fasteners not extend into flexible lower flange 12 as this could result in weak points where moisture may easily access below outer cladding 24.

15

20

[0032] Referring to **FIG. 4**, when in use, seal 10 is slid over protrusion 22 such that wall 18 of central aperture 16 encircles protrusion 22. Since protrusion 22 may have different diameters, different sized seals 10 with different sized central apertures 16 may be provided. Once positioned around protrusion 22, a bottom of flexible lower flange contacts a surface from which the protrusion extends. The surface may be a wall, insulation material 26, or any other surface known to a person skilled in the art. Outer cladding 24 is slid between flexible upper flange 14 and flexible lower flange 12. Outer cladding 24 has a cut out sized such that it is larger than central aperture 16 and smaller than flexible lower flange 12 and flexible upper flange 14. Outer cladding 24 may be separated into multiple pieces with cut out being divided between the pieces of outer cladding 24.

25

30

[0033] For improved sealing and to help limit moisture ingress below outer cladding 24, a sealant may be used to seal flexible upper flange 14 to outer cladding 24. When outer cladding 24 is separated into multiple pieces, sealant may be used to seal the multiple pieces together. Sealant may include silicon or any other suitable type of sealant known to a person skilled in the art.

[0034] Any use herein of any terms describing an interaction between elements is not meant to limit the interaction to direct interaction between the subject elements, and may also include indirect interaction between the elements such as through secondary or intermediary structure unless
5 specifically stated otherwise.

[0035] In this patent document, the word “comprising” is used in its non-limiting sense to mean that items following the word are included, but items not specifically mentioned are not excluded. A reference to an element by the indefinite article “a” does not exclude the possibility that more than one
10 of the element is present, unless the context clearly requires that there be one and only one of the elements.

[0036] It will be apparent that changes may be made to the illustrative embodiments, while falling within the scope of the invention. As such, the scope of the following claims should not be limited by the preferred embodiments set forth in the examples and drawings described above, but should be given
15 the broadest interpretation consistent with the description as a whole.

CLAIMS

What is claimed is:

1. A seal for a protrusion in an insulated pipe system, comprising:
 - a flexible lower flange;
 - a flexible upper flange, the flexible upper flange having at least one fastening aperture through which a corresponding fastener passes for fastening the flexible upper flange to a surface
 - an aperture extending through the flexible lower flange and the flexible upper flange, the aperture having a wall, the wall attaching the flexible lower flange to the flexible upper flange such that the flexible lower flange and the flexible upper flange are spaced from each other, the at least one fastening aperture being positioned externally to the wall; and
 - a slit extending from an outer edge of the flexible lower flange through the flexible upper flange and the wall of the aperture such that the slit allows the flexible lower flange and the flexible upper flange to bend and be slid over a protrusion such that the wall of the aperture encircles the protrusion and the flexible lower flange and the flexible upper flange unbend to their original shape.
2. The seal for a protrusion of claim 1 wherein the flexible upper flange is smaller in size than the flexible lower flange.
3. The seal for a protrusion of claim 1 wherein the wall of the aperture extends upwards away from the flexible upper flange.
4. The seal for a protrusion of claim 1 wherein the flexible lower flange and the flexible upper flange are circular in shape.
5. The seal for a protrusion of claim 1 wherein the flexible lower flange and the flexible upper flange are made of silicon.
6. The seal for a protrusion of claim 1 wherein the flexible lower flange, the flexible upper flange and the wall of the aperture are integrally formed.

7. The seal for a protrusion of claim 1 wherein the aperture is positioned centrally through flexible lower flange and flexible upper flange.

8. A method of sealing a protrusion in an insulated pipe system, comprising the steps of:

providing a seal, the seal having:

a flexible lower flange

a flexible upper flange, the flexible upper flange having at least one fastening aperture through which a corresponding fastener passes for fastening the flexible upper flange to a surface;

an aperture extending through the flexible lower flange and the flexible upper flange, the aperture having a wall, the wall attaching the flexible lower flange to the flexible upper flange such that the flexible lower flange and the flexible upper flange are spaced from each other, the at least one fastening aperture being positioned externally to the wall; and

a slit extending from an outer edge of the flexible lower flange through the flexible upper flange and the wall of the aperture such that the slit allows the flexible lower flange and the flexible upper flange to bend and be slid over a protrusion such that the wall of the aperture encircles the protrusion and the flexible lower flange and the flexible upper flange unbend to their original shape;

sliding the seal over the protrusion such that the wall of the aperture encircles the protrusion and the flexible lower flange and the flexible upper flange return to their original shape, a bottom of the flexible lower flange contacting a surface from which the protrusion extends;

sliding an outer cladding between the flexible upper flange and the flexible lower flange, the outer cladding having a cut out sized such that the cut out is larger than the aperture and smaller than the flexible lower flange and the flexible upper flange.

9. The method of claim 8 wherein the outer cladding is separated into two pieces with the cut out being divided between the two pieces.

10. The method of claim 8 further comprising the step of using a sealant to seal the flexible upper flange to the outer cladding.

11. The method of claim 9 further comprising the step of using a sealant to seal the two pieces of the outer cladding together.

12. The method of claim 8 wherein the flexible upper flange is smaller in size than the flexible lower flange.

13. The method of claim 8 wherein the wall of the aperture extends upwards away from the flexible upper flange.

14. The method of claim 8 wherein the flexible lower flange and the flexible upper flange are circular in shape.

15. The method of claim 8 wherein the flexible lower flange and the flexible upper flange are made of silicon.

16. The method of claim 8 wherein the flexible lower flange, the flexible upper flange and the wall of the aperture are integrally formed.

17. The method of claim 8 wherein the aperture is positioned centrally through flexible lower flange and flexible upper flange.

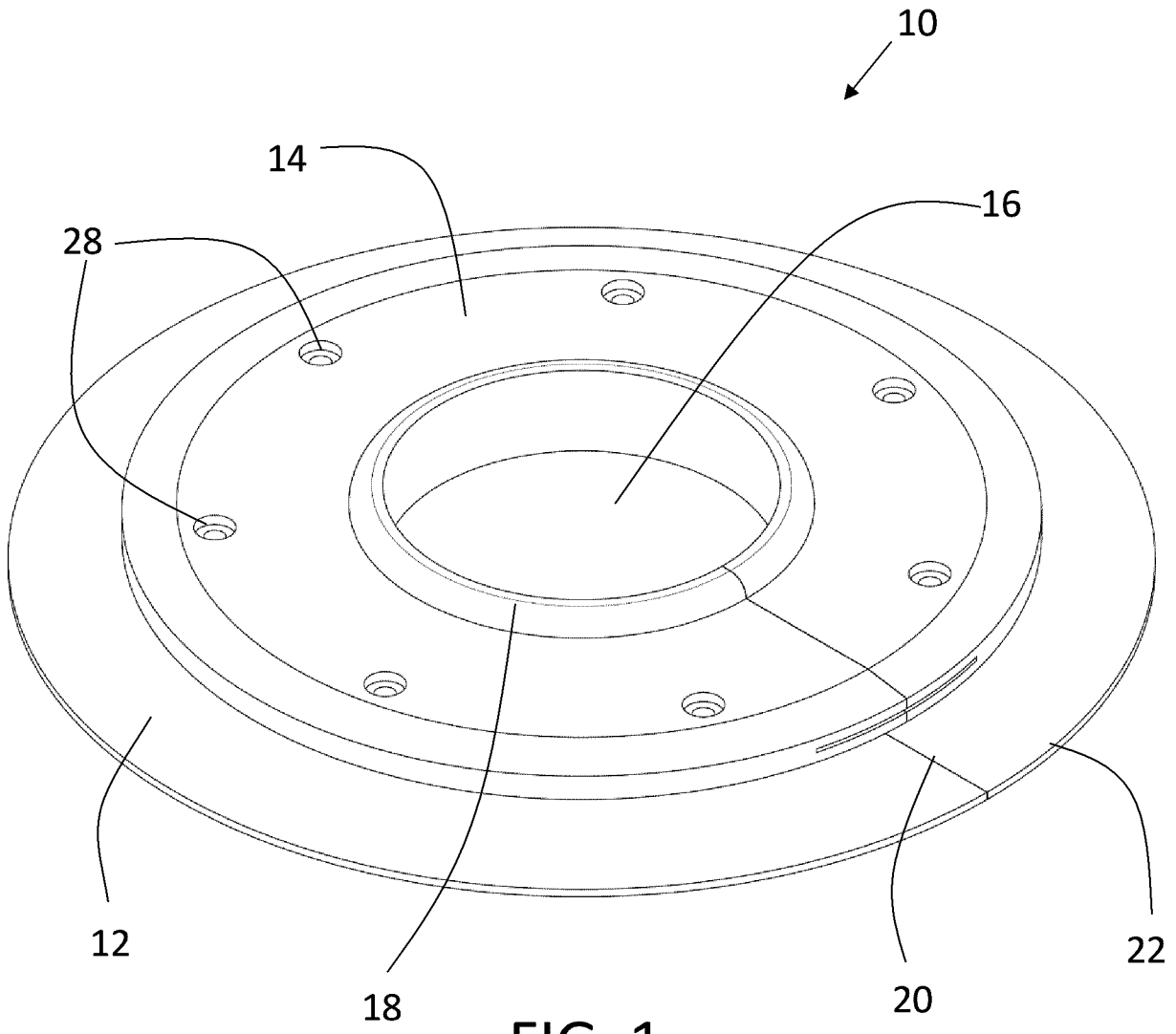
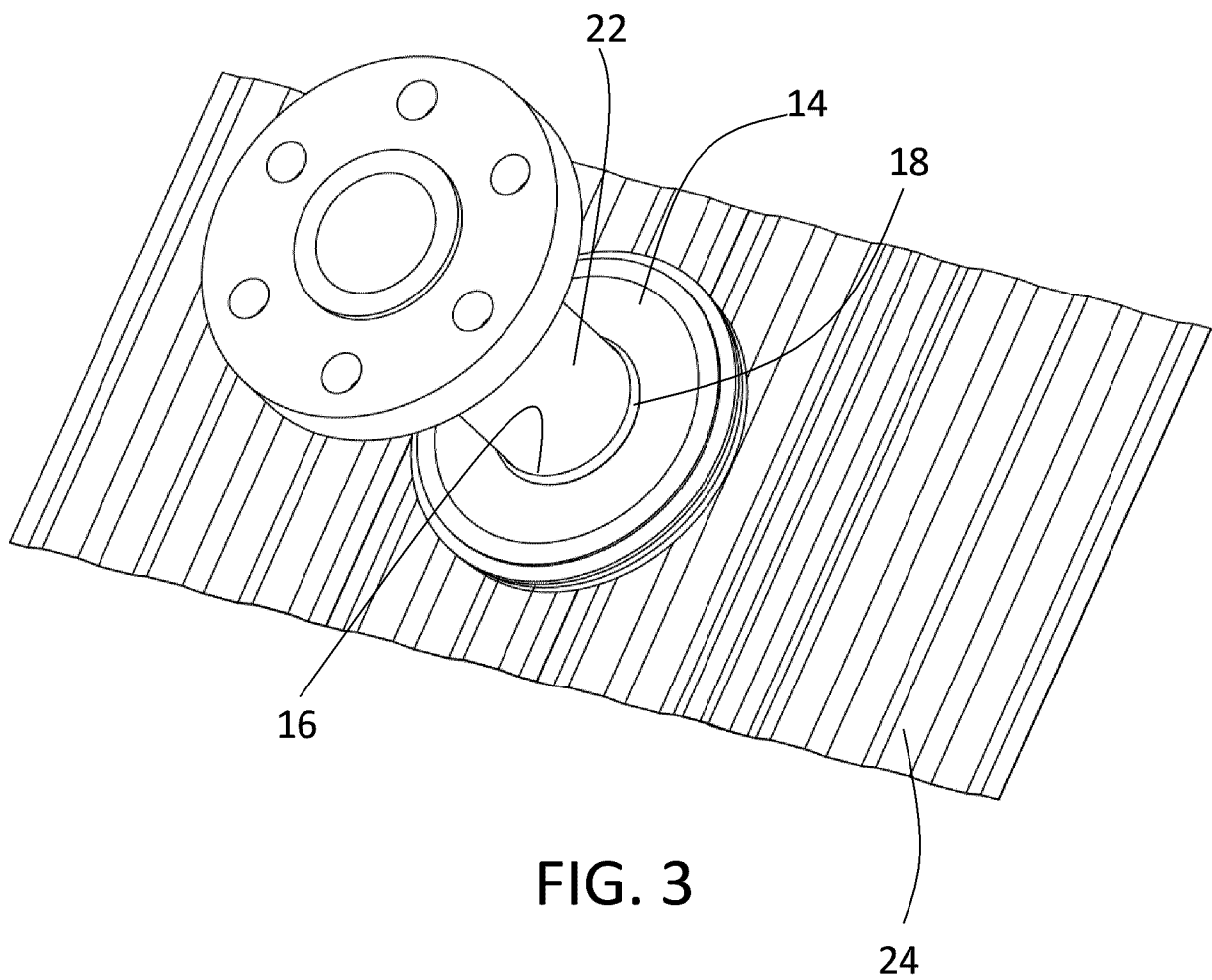
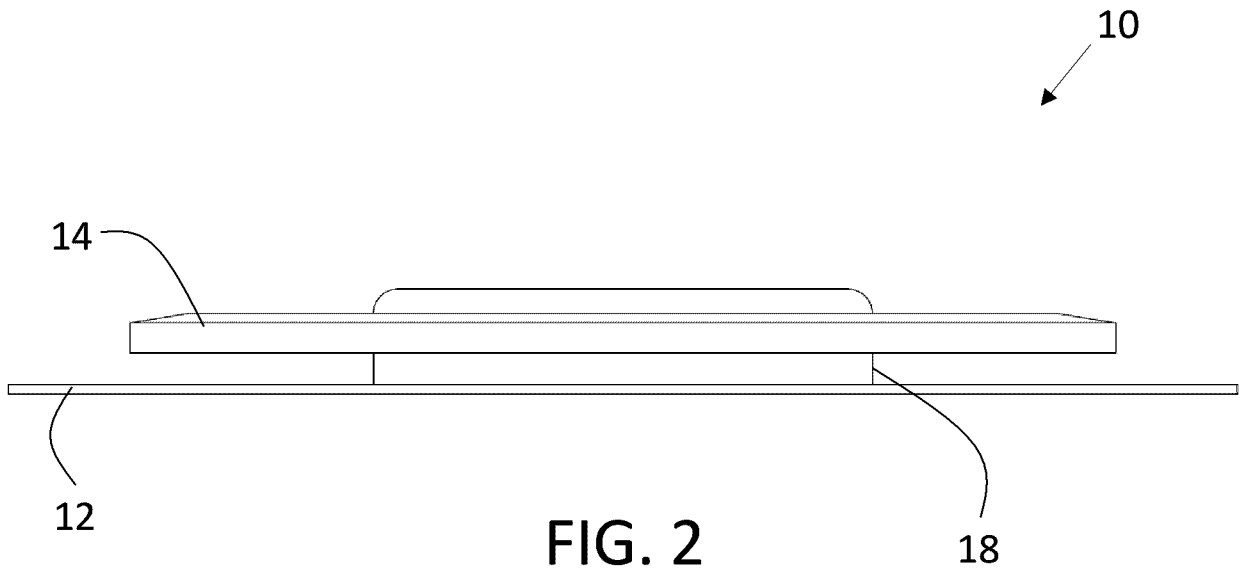

FIG. 1



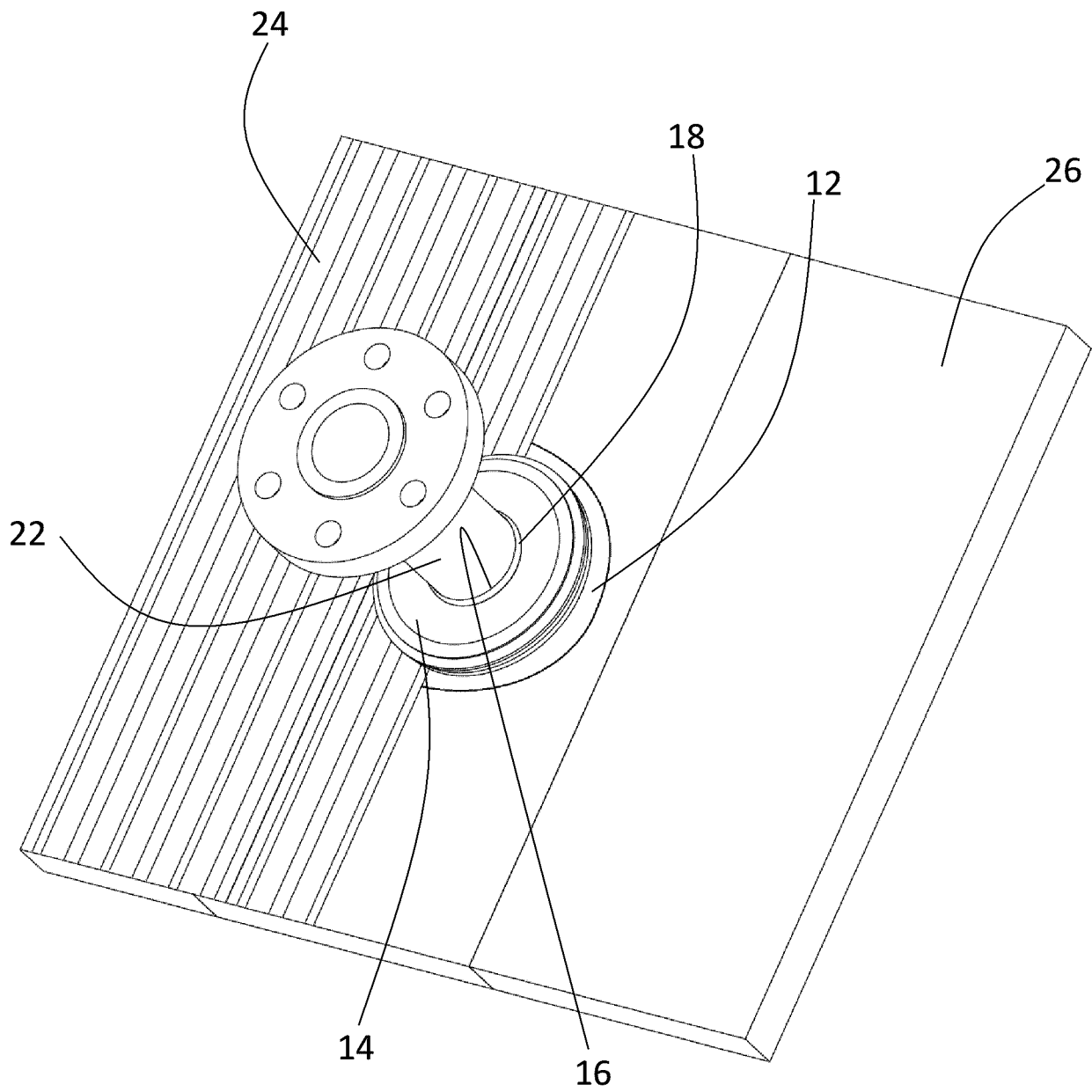

FIG. 4

