

McOMBER & WARD.

Coupling Device.

No. 100,542.

Patented March 8, 1870.

Fig. 1

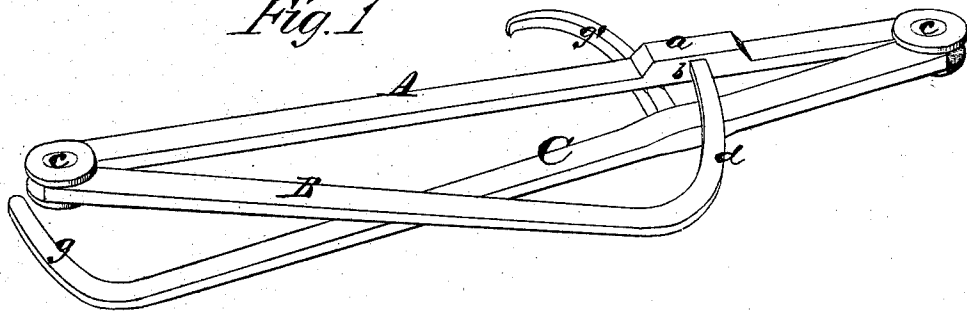

Fig. 2

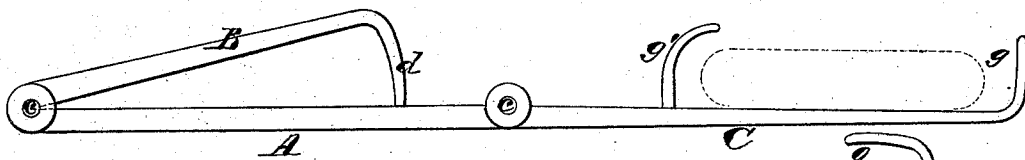
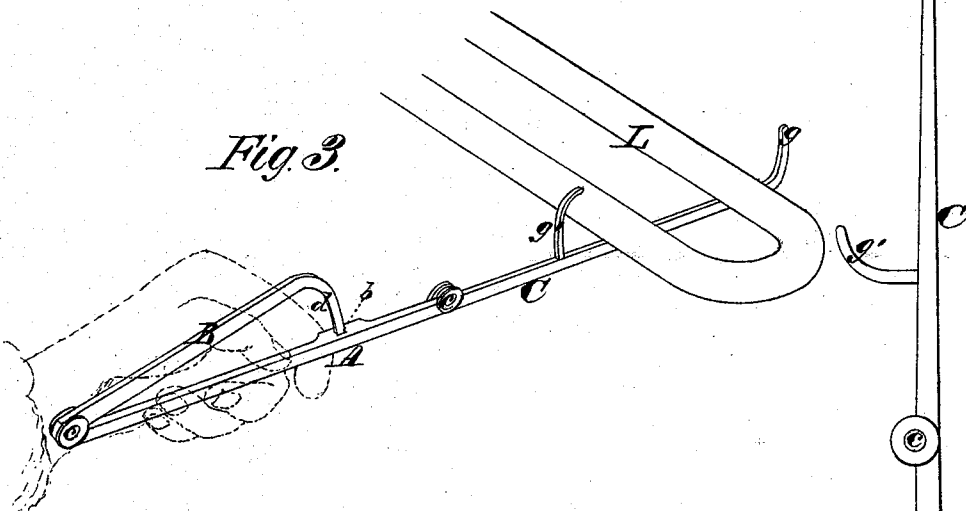

Fig. 3



Witnesses.
R. T. Campbell
J. A. Campbell

Inventors
A. Mcomber
Wm. Ward
By
Wm. Smith & Lawrence

Fig. 4

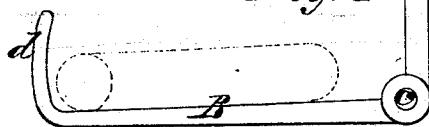

United States Patent Office.

ABNER McOMBER AND MINA WARD, OF SCHENECTADY, NEW YORK.

Letters Patent No. 100,542, dated March 8, 1870.

IMPROVED INSTRUMENT FOR COUPLING RAILWAY-CARS.

The Schedule referred to in these Letters Patent and making part of the same.

To all whom it may concern:

Be it known that we, ABNER McOMBER and MINA WARD, of Schenectady, in the county of Schenectady, and State of New York, have invented a new and improved Instrument for Coupling Railroad-Cars; and we do hereby declare that the following is a full, clear, and exact description thereof, reference being had to the accompanying drawings making a part of this specification in which—

Figure 1 is a perspective view of the improved instrument folded up.

Figure 2 is a side view of the instrument arranged for coupling freight-cars.

Figure 3 is a perspective view of the instrument adjusted as shown in fig. 2, and supporting one end of a link.

Figure 4 is a view of the instrument adjusted for coupling passenger or platform-cars.

Similar letters of reference indicate corresponding parts in the several figures.

The object of our invention is to obtain a portable instrument by which the coupling-links of passenger-cars or freight-cars can be conveniently and safely held up and guided into their places during the act of moving cars together to couple them. To this end,

The nature of our invention consists in a rod, of suitable length and strength, provided with hooks or lugs in such manner that a coupling-link can be readily held up and guided into its place by a person standing on the platform of a car, or on the ground on one side of the cars, as will be hereinafter explained.

To enable others skilled in the art to understand our invention, we will describe its construction and operation.

In the accompanying drawings, we have represented the improved coupling instrument made of three sections, A B C, connected together by rule-joint *c c*.

We prefer to construct the staff of the instrument in this way, in order that it can be folded into a small compass when not in immediate use, and thus allowing it to be conveniently carried.

The free end *d* of the section B is hooked or bent at right angles to this section, so that when the latter is adjusted at right angles to the two sections A C, as shown in fig. 4, it will afford a support for one end of

a coupling-link, and allow such link to be held and guided into its place during the act of effecting a coupling.

The person holding the instrument when it is thus adjusted will be stationed on the platform of one of the cars, and will grasp the instrument by its hooked section C.

For coupling freight-cars, where a person who guides the links is required to station himself on one side of the track, and not on the platform, as in passenger-cars, the instrument is adjusted as shown in figs. 2 and 3.

The section C is adjusted in a straight line with section A, and the section B is turned over, as shown in figs. 2 and 3, and its hooked end, *d*, inserted into a recess, *b*, in the edge of section A.

This forms a handle, A B, by which the instrument can be firmly grasped and held while using it.

The section C has its end *g* turned up to form a hook or lug, and it also has a corresponding hook or lug, *g'*, secured to it at such distance from *g* as will allow a coupling-link to be received between these hooks. When thus held on the section C, the coupling-link can be guided into its place without requiring the person making the coupling to expose any part of his person between the cars.

When the instrument is not in immediate use, its sections can be folded, as shown in fig. 1, and may be carried in the pocket.

Having described our invention,

What we claim as new, and desire to secure by Letters Patent, is—

1. A rod or staff, provided with hooks or lugs *g g'* and *d*, and adapted for supporting and guiding coupling-links during the act of coupling cars, substantially as described.

2. Constructing such a rod or staff of sections A, B, and C, connected together by rule-joints, substantially as described.

ABNER McOMBER.
MINA WARD.

Witnesses:

CHAS. E. PALMER,
E. L. FREEMAN, 2d.